

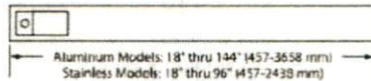

# GLO-RAY<sup>®</sup> INFRARED FOODWARMERS

Models GRAH-18, -24, -30, -36, -42, -48, -54, -60, -66, -72, -84, -96, -108, -120, -132, -144  
GRA-18, -24, -30, -36, -42, -48, -54, -60, -66, -72, -84, -96, -108, -120, -132, -144

GRH-18, -24, -30, -36, -42, -48, -54, -60, -66, -72, -84, -96  
GR-18, -24, -30, -36, -42, -48, -54, -60, -66, -72, -84, -96



FRONT VIEW

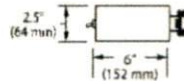

END VIEW

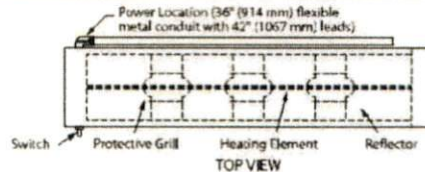

TOP VIEW

## SPECIFICATIONS

Aluminum High Watt		Aluminum Standard Watt			
Model	Watt	Model	Watt	Width	Shipping Weight*
GRAH-18	350	GRA-18	250	18" (457 mm)	6 lbs. (3 kg)
GRAH-24	500	GRA-24	350	24" (610 mm)	7 lbs. (3 kg)
GRAH-30	660	GRA-30	450	30" (762 mm)	8 lbs. (4 kg)
GRAH-36	800	GRA-36	575	36" (914 mm)	9 lbs. (4 kg)
GRAH-42	950	GRA-42	675	42" (1067 mm)	10 lbs. (5 kg)
GRAH-48	1100	GRA-48	800	48" (1219 mm)	11 lbs. (5 kg)
GRAH-54	1250	GRA-54	925	54" (1372 mm)	13 lbs. (6 kg)
GRAH-60	1400	GRA-60	1050	60" (1524 mm)	14 lbs. (6 kg)
GRAH-66*	1560	GRA-66	1160	66" (1676 mm)	16 lbs. (7 kg)
GRAH-72*	1725	GRA-72	1275	72" (1829 mm)	17 lbs. (8 kg)
GRAH-84**	2050	GRA-84*	1500	84" (2134 mm)	19 lbs. (9 kg)
GRAH-96**	2400	GRA-96*	1725	96" (2438 mm)	21 lbs. (10 kg)
GRAH-108	2500	GRA-108	1850	108" (2743 mm)	23 lbs. (10 kg)
GRAH-120	2800	GRA-120	2100	120" (3048 mm)	26 lbs. (12 kg)
GRAH-132	3120	GRA-132	2320	132" (3353 mm)	30 lbs. (14 kg)
GRAH-144	3450	GRA-144	2550	144" (3658 mm)	33 lbs. (15 kg)

Stainless High Watt		Stainless Standard Watt			
Model	Watt	Model	Watt	Width	Shipping Weight*
GRH-18	350	GR-18	250	18" (457 mm)	7 lbs. (3 kg)
GRH-24	500	GR-24	350	24" (610 mm)	7 lbs. (3 kg)
GRH-36	800	GR-36	575	36" (914 mm)	10 lbs. (5 kg)
GRH-48	1100	GR-48	800	48" (1219 mm)	12 lbs. (5 kg)
GRH-60	1400	GR-60	1050	60" (1524 mm)	15 lbs. (7 kg)
GRH-72	1725	GR-72	1275	72" (1829 mm)	19 lbs. (9 kg)
GRH-96	2400	GR-96	1725	96" (2438 mm)	24 lbs. (11 kg)

\* Does not include RMB.

\*\* When using an infinite control with 120 volt model, tandem elements are required, cord not available.

† 120 volt models require additional switches and tandem (end-to-end) elements.

## OPTIONS (NOT FOR RETROFIT)

- Designer Colors, Aluminum Models 18" to 144" (457-3658 mm): Warm Red, Black, Gray Granite, White Granite, Navy Blue, Hunter Green, Antique Copper
  - Gloss Finishes, Aluminum Models 18" to 144" (457-3658 mm): Smooth White, Gleaming Gold, Glossy Gray, Bold Black, Radiant Red, Brilliant Blue
  - Indicator Light
  - Tandem Charge (Max. two elements end-to-end)
  - Extended Electrical Leads
  - Sneeze Guard (Aluminum models only)
  - Incandescent Lights available, see GR-L Spec Sheet
  - Infinite Control\* (Remote Recommended)
  - Remote Control Enclosure
- † Maximum of 12.2 amps. Consult factory if rating of single element at 120 volts exceeds 1400 watts.

## PRODUCT SPECS Infrared Foodwarmer

The Infrared Foodwarmer shall be a Glo-Ray<sup>®</sup>, manufactured by the Hatco Corporation, Milwaukee, WI 53234 U.S.A.  
With 24/7 parts and service assistance (U.S. and Canada only), the Foodwarmer shall be a Glo-Ray Model ..., rated at ... watts, ... volts, single phase and be ... inches (millimeters) in overall width.  
The Glo-Ray shall consist of either a stainless steel or aluminum housing and include as standard equipment four stainless steel shelf mounting tabs and

## DIMENSIONS

18" to 144"W x 6"D x 2.5"H (457-3658 x 152 x 64 mm).

For special lengths, consult factory.

Aluminum models from 18" through 12" (457-3658 mm). Available in 6" (152 mm) increments up to 144" (3658 mm) maximum width.

## VOLTAGE

120, 208 and 240 volts, single phase. Consult factory for Models GRAH-84, GRH-96 and GRAH-96 in 120 volt, and models with tandem elements (208 or 240V).

Export voltages available.

## PLUG CONFIGURATION

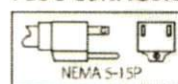

120 volts only - Models 6' (1829 mm) or less with C-Leg or T-Leg stand or Chain kit only.

## MOUNTING REQUIREMENTS

Recommended Mounting Height - Standard Watt 8"-11" (203-279 mm)  
- High Watt 11"-14" (279-356 mm)

## MINIMUM SPACING -

Combustibles: 13.5" (343 mm) (high watt) or 10" (254 mm) (standard watt) below, 1" (25 mm) above, and 3" (76 mm) to back wall. Non-combustibles: 1" (25 mm) above, 10" (254 mm) (high watt with infinite or indicator lamp), and 8" (203 mm) (high watt toggle or standard watt) below. Must be installed in a pass through area. Units with remote switches may be installed against a non-combustible back wall, flush to an overshelf, and 8" (203 mm) to a surface below. Maximum 10" (254 mm) setback from the front of an overshelf. Models with cords must be installed 3" (76 mm) below an overshelf and 11" (279 mm) (high watt) or 10" (254 mm) (standard watt) over a surface below.

## REMOTE CONTROL ENCLOSURES

Model	Width	Toggle Switches
RMB-3	5.5" (140 mm)	2 Maximum
RMB-7	9" (229 mm)	4 Maximum
RMB-14	14" (356 mm)	6 Maximum
RMB-16	16" (406 mm)	3 Maximum
RMB-20	20" (508 mm)	3 Maximum

## ONE CONTROL BOX PER FOODWARMER.

□ 6' (1829 mm) Cord and Plug Set (120V only)†

\* Available on models 6' (1829 mm) or less with C-Leg or T-Leg stand or Chain kit only.

## ACCESSORIES

- Adjustable Tubular Stands 10"-14" (254-356 mm)
- Non-Adjustable Tubular Stands 10", 12", 14", or 16" (254, 305, 356, or 406 mm) - Available in Designer colors
- C-Leg Stands for Models up to 6' (1829 mm) (10" or 13.5" (254 or 343 mm) clearance)
- T-Leg Stands for Models up to 6' (1829 mm) (10", 13.5", 16", or 18" (254, 343, 406, or 457 mm) clearance)
- Adjustable Angle Brackets (Provides 1" - 2" (25-51 mm) clearance above unit)
- Chain Suspension

an on-off switch may be optionally installed to either the front or rear of the unit. The infrared heating element shall be tubular metal sheathed. The foodwarmer shall be factory assembled ready for electrical installation.

Options and accessories shall include adjustable or non-adjustable tubular stand, C-leg stand, T-leg stand, angle brackets, suspension chain and fittings, breath protector, cord and plug set, indicator light, and infinite control - remote or built-in.

HATCO CORPORATION P.O. Box 340500 Milwaukee, WI 53234-0500 U.S.A. • (800) 558-0607 • (414) 671-6350  
Fax (800) 543-7521 • Int'l. Fax (414) 671-3976 • www.hatcocorp.com • E-mail: equipsales@hatcocorp.com

Form No. GR Spec Sheet

Printed in U.S.A.  
April 2009

PROJECT: \_\_\_\_\_

MODEL: \_\_\_\_\_

ITEM #: \_\_\_\_\_ QUANTITY: \_\_\_\_\_

APPROVAL: \_\_\_\_\_ DATE: \_\_\_\_\_



## Full Size Electric Countertop Food Warmer

### ITEM NUMBER

#177W50

### SPECIAL FEATURES

- Maintains foodsafe temperatures for hours
- Heavy duty water well
- Heating element supports direct heat to food
- 27 qt. capacity

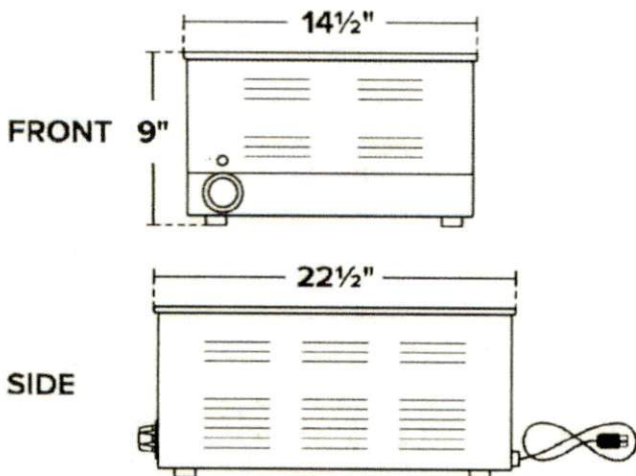
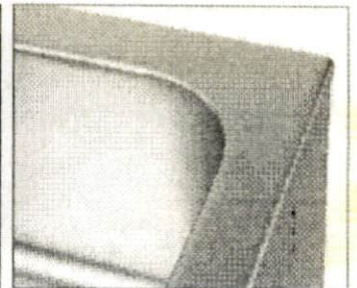
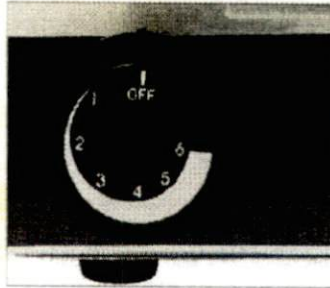

### TECHNICAL DATA

Interior Dimensions	12" x 20" x 7 1/2"
Exterior Dimensions	14 1/2" x 22 1/2" x 9"
Control Type	Thermostatic
Voltage	120V
Wattage	1200W
Hertz	60Hz
Amps	10 Amps
Phase	1



5-15P

## Circuit Diagram

LEGEND	DESCRIPTION
XL	25A/300V
HL1	120V
QS	16A/250V
EH1, EH2	710W, 1040W/120V
∞	12x12/120V
M	120V/60Hz
R	30W/15Ω
θS	90°C 16A/250V
D	IN540B/4A

### WIRING DIAGRAM

MODEL: CONVEYOR TOASTER  
177GCT10  
1.75kW/120VAC/50-60Hz

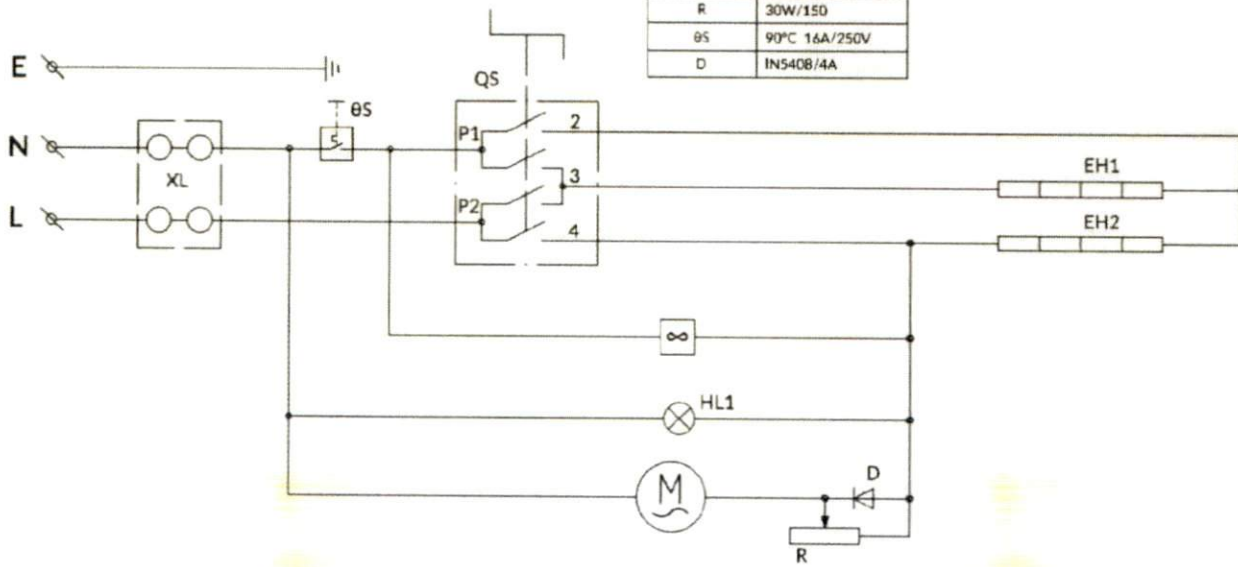

## Discharge Assembly

As detailed in the diagrams below, the unit can either be assembled with front or rear discharge depending on installation position and preference.

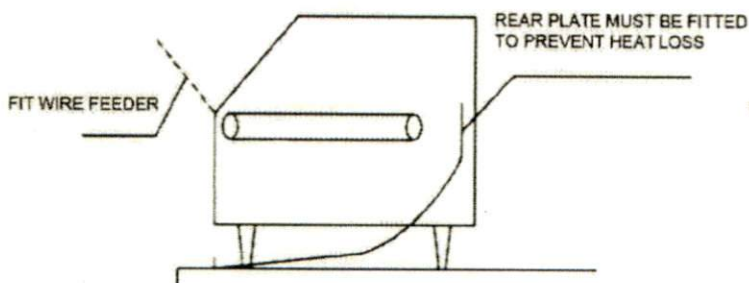

### FRONT DISCHARGE

1. Pull metal plate up to the closed position and latch. This will direct food to the bottom of the toaster.
2. Pick up the longer of the two chutes.
3. Slide the flanged end of the chute up underneath the toaster.
4. Rest the flanged end of the chute onto the interior ledge.

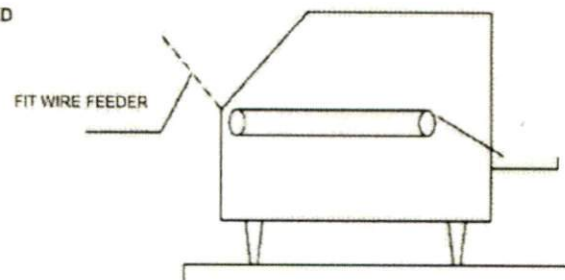

### REAR DISCHARGE

1. Push the metal plate down to the open position. This will direct food to the back of the toaster.
2. Loosen the two rear screws.
3. Pick up the smaller of the two chutes.
4. Slide the two keyholes on the chute behind the loosened screws. If the chute does not fit all the way down, loosen the screws more.
5. Tighten the screws to secure the chute to the toaster.

## Before Using Your Toaster

**Before cooking anything in your oven for the first time, please follow these simple instructions:**

1. This conveyor toaster has been designed to continuously produce toasted bread or buns. The desired toasted color of the product can be adjusted by changing the belt speed of the conveyor. Depending on installation position, the toasted product can be discharged to the front or rear of the unit.
2. Ensure the support feet are assembled to the unit before commencing operation.
3. Thoroughly clean as described in the cleaning section of this manual (page 6).
4. For best results, allow the unit to preheat for 20-25 minutes before use so that the correct operating temperature can be reached.

 <b>TRUE MANUFACTURING CO., INC.</b> <b>U.S.A. FOODSERVICE DIVISION</b> 2001 East Terra Lane • O'Fallon, Missouri 63366-4434 • (636)240-2400 Fax (636)272-2408 • Toll Free (800)325-6152 • Intl Fax# (001)636-272-7546 Parts Dept. (800)424-TRUE • Parts Dept. Fax# (636)272-9471 • www.truemfg.com	<b>Project Name:</b> _____ <b>Location:</b> _____ <b>Item #:</b> _____ <b>Qty:</b> _____ <b>Model #:</b> _____	<b>AIA #</b>  <b>SIS #</b>
	<b>Model:</b> <b>T-72F-HC</b>	

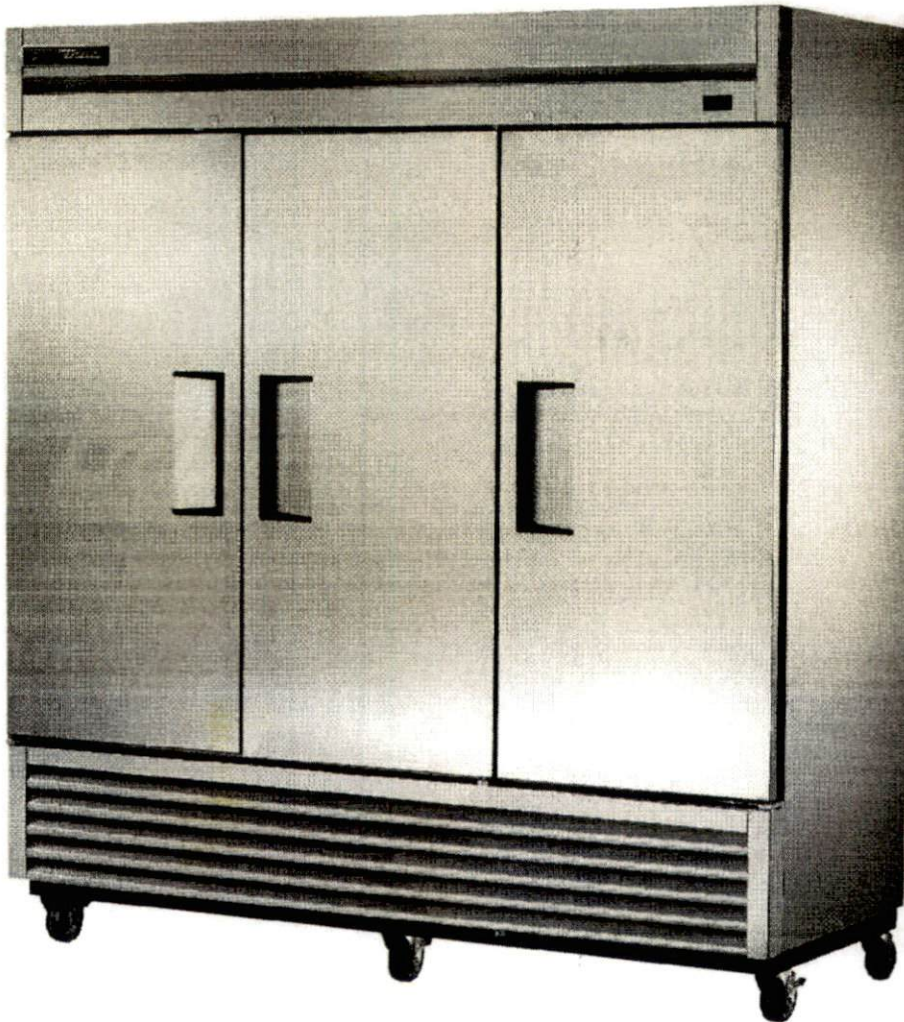





- ### T-72F-HC
- ▶ True's solid door reach-ins are designed with enduring quality that protects your long term investment.
  - ▶ Designed using the highest quality materials and components to provide the user with colder product temperatures, lower utility costs, exceptional food safety and the best value in today's food service marketplace.
  - ▶ Factory engineered, self-contained, capillary tube system using environmentally friendly R290 hydrocarbon refrigerant that has zero (0) ozone depletion potential (ODP), & three (3) global warming potential (GWP).
  - ▶ High capacity, factory balanced refrigeration system that maintains -10°F (-23.3°C) temperatures. Ideal for both frozen foods and ice cream.
  - ▶ Stainless steel solid doors and front. The very finest stainless with higher tensile strength for fewer dents and scratches.
  - ▶ Adjustable, heavy duty PVC coated shelves.
  - ▶ Positive seal self-closing doors. Lifetime guaranteed door hinges and torsion type closure system.
  - ▶ Automatic defrost system time-initiated, temperature-terminated. Saves energy consumption and provides shortest possible defrost cycle.
- Bottom mounted units feature:**
- ▶ "No stoop" lower shelf.
  - ▶ Storage on top of cabinet.
  - ▶ Compressor performs in coolest, most grease free area of kitchen.
  - ▶ Easily accessible condenser coil for cleaning.

## ROUGH-IN DATA

Specifications subject to change without notice.  
 Chart dimensions rounded up to the nearest 1/8" (millimeters rounded up to next whole number).

Model	Doors	Shelves	Cabinet Dimensions (inches) (mm)			HP	Voltage	Amps	NEMA Config.	Cord Length (total ft.) (total m)	Crated Weight (lbs.) (kg)
			W	D	H*						
T-72F-HC	3	9	78 1/8 1985	29 1/2 750	78 3/8 1991	3/4 N/A	115/60/1	14.0 N/A	5-20P	9 2.74	650 295

\* Height does not include 5" (127 mm) for castors or 6" (153 mm) for optional legs.

   	<b>APPROVALS:</b>  	<b>AVAILABLE AT:</b>  
5/20 Printed in U.S.A.		

# REFRIGERATION AVANTCO

## SS Series Solid Door Reach-In Refrigerators & Freezers

MODEL #178SS2RHC

### CABINET CONSTRUCTION

Heavy duty all-stainless steel construction includes corrosion-resistant 304 stainless steel interior and durable 430 stainless steel exterior.

Foamed-in-place CFC- and HCFC-free polyurethane insulation enhances the structural integrity of the cabinet and helps increase energy efficiency.

Removable one-piece grill simplifies cleaning and servicing.

Stainless steel solid doors have stay-open feature beyond 90° for easy loading, but will self-close under 90° to save energy. Each door is outfitted with an easy-to-grasp full length handle.

### REFRIGERATION SYSTEM

Environmentally-safe R290 refrigerant. Bottom-mounted condensing unit positioned for easy maintenance.

"No stoop" lower shelf raises product to a higher level for easy access.

### SHELVING

6 gray epoxy-coated steel shelves included. Each accommodates up to 120 lb.

### MODEL FEATURES

Preprogrammed digital controls feature auto-defrost function.

Shelf rails accommodate full size food pans for storage flexibility. Optional bun pan rails accommodate full size bun pans.

Interior back panel separates shelf and back wall to promote proper airflow.

PROJECT: \_\_\_\_\_

MODEL: \_\_\_\_\_ SERIAL#: \_\_\_\_\_

ITEM #: \_\_\_\_\_ QUANTITY: \_\_\_\_\_

APPROVAL: \_\_\_\_\_ DATE: \_\_\_\_\_

### SS SERIES REACH-IN REFRIGERATOR

Keep ingredients within a safe temperature range in a sleek, durable, and easy-to-clean environment

### SPECIAL FEATURES

- Self-closing doors with convenient stay-open feature
- Easy-to-clean 430 series stainless steel exterior
- Corrosion-resistant 304 series stainless steel interior
- Temperature range of 33-40°F
- 6 shelves included; versatile shelf slide design also accepts full size food pans
- Environmentally-safe R290 refrigerant
- Digital temperature controller with automatic defrost function
- 115V; 1/4 HP
- ETL Safety & Sanitation Listed

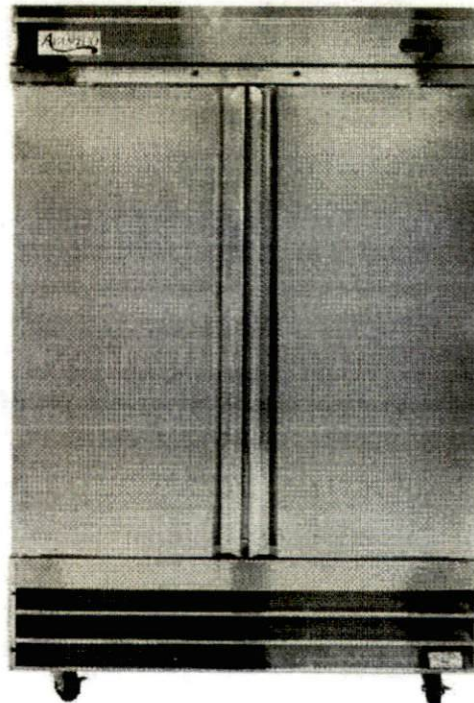

### WARRANTY

RESIDENTIAL: Avantco assumes no liability for parts or labor coverage for component failure, factory defect or any other damages for units installed in non-commercial foodservice or residential applications.



Parts & Labor



Compressor



★ Conforms to UL & NSF-7 Standards

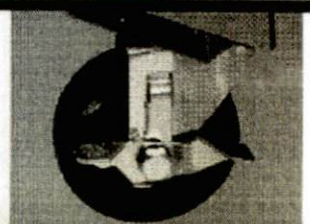
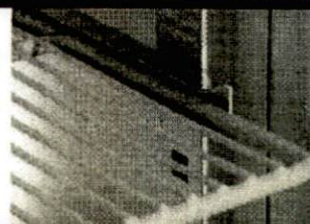
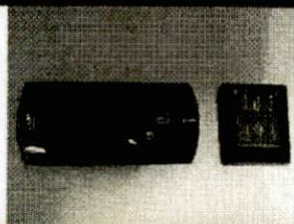

**HOOD INFORMATION - Job#3955543**

HOOD NO.	TAG	MODEL	LENGTH	MAX. COOKING TEMP.	APPLIANCE DUTY	DESIGN CFM/ft	TOTAL EXH. CFM	EXHAUST PLENUM RISER(S)				
								WIDTH	LENG.	HEIGHT	DIA.	C
1		5424 ND-2-PSP-F	6' 6"	600 Deg.	Heavy	205	1332			4"	12"	13"

**HOOD INFORMATION**

HOOD NO.	TAG	FILTER(S)					LIGHT(S)	
		TYPE	QTY.	HEIGHT	LENGTH	EFFICIENCY @ 7 MICRONS	QTY.	TYPE
1		Captrate Solo Filter	4	20"	16"	85% See Filter Spec.	4	L55 Series E

**HOOD OPTIONS**

HOOD NO.	TAG	OPTION
1		FIELD WRAPPER 18.00" High Front, Right
		BACKSPLASH 80.00" High X 91.00" Long 430 SS Vertical
		LEFT END STANDOFF (FINISHED) 1" Wide 54" Long Insulated
		INSULATION FOR BACK OF HOOD
		RISER SENSOR INSTALL 6IN PLEN
		RIGHT VERTICAL END PANEL 27" Top Width, 21" Bottom Width, 80" High In SS
		LEFT WALL AS END PANEL

**PERFORATED SUPPLY PLENUM(S)**

HOOD NO.	TAG	POS.	LENGTH	WIDTH	HEIGHT	TYPE	RISER(S)				
							WIDTH	LENG.	DIA.	CFM	S.P.
1		Front	91"	14"	6"	MUA	12"	20"		533	0.156"
						MUA	12"	20"		533	0.156"



GREASE DUCT & CHIMNEY SPECIFICATIONS:  
 PROVIDE GREASE DUCT EQUAL TO CAPTIVEAIRE S  
 ROUND 20 GAUGE 430 STAINLESS STEEL DUCTWOR  
 IS LISTED TO UL-1978 AND IS INSTALLED USING

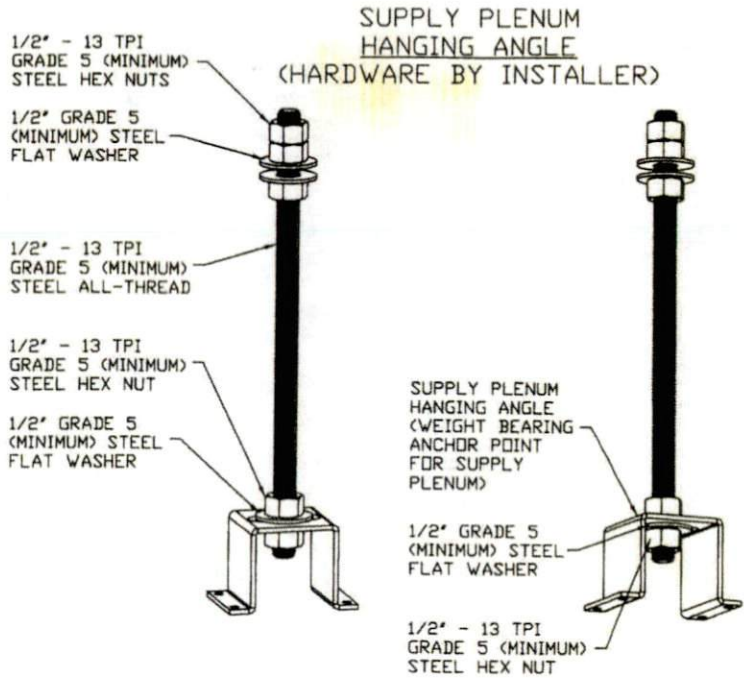

### ASSEMBLY INSTRUCTIONS

HANGING ANGLE MUST BE SUPPORTED WITH 1/2" - 13 TPI GRADE 5 (MINIMUM) ALL-THREAD. SANDWICH HANGING ANGLES AND CEILING ANCHOR POINTS WITH 1/2" GRADE 5 (MINIMUM) STEEL FLAT WASHERS AND 1/2" - 13 TPI GRADE 5 (MINIMUM) HEX NUTS AS SHOWN. MUST USE DOUBLED HEX NUT CONFIGURATION ABOVE CEILING ANCHORS. SINGLE HEX NUT BENEATH HANGING ANGLE IS ACCEPTABLE FOR PSP HANGING ANGLES. MAINTAIN 1/4" OF EXPOSED THREADS BENEATH BOTTOM HEX NUT. TORQUE ALL HEX NUTS TO 57 FT-LBS.

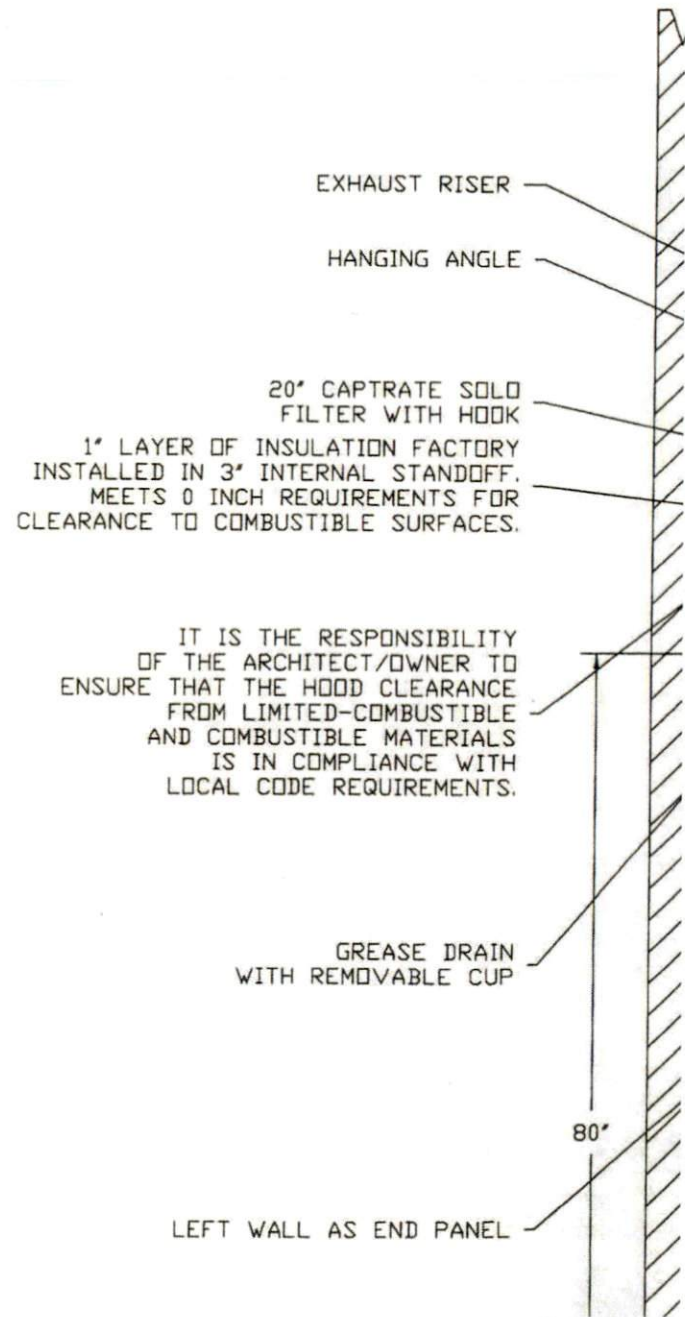



**EXHAUST FAN INFORMATION - Job#3955543**

FAN UNIT NO.	TAG	FAN UNIT MODEL #	CFM	ESP.	RPM	H.P.	B.H.P.	Ø	VOLT	FLA
1	KEF-1	DU85HFA	1332	1.000	1187	1.000	0.3320	1	115	10.2

**MUA FAN INFORMATION - Job#3955543**

FAN UNIT NO.	TAG	FAN UNIT MODEL #	BLOWER	HOUSING	MIN CFM	DESIGN CFM	ESP.	RPM	H.P.
2	KMUA-1	A1-G10	G10D	A1	0	1066	0.500	810	1.000

**FAN OPTIONS**

FAN UNIT NO.	TAG	OPTION (Qty. - Descr.)
1	KEF-1	1 - Grease Box 1 - ECM Wiring Package-Exhaust - PWM Signal from ECPM03 Prewire (NIDEC Motor)
2	KMUA-1	1 - ECM Wiring Package-Supply - PWM Signal from ECPM03 Prewire (NIDEC Motor)

**FAN ACCESSORIES**

FAN UNIT NO.	TAG	EXHAUST			SUPPLY			
		GREASE CUP	GRAVITY DAMPER	WALL MOUNT	SIDE DISCHARGE	GRAVITY DAMPER	MOTORIZED DAMPER	WALL MOUNT
1	KEF-1	YES						
2	KMUA-1							

**CURB ASSEMBLIES**

NO.	ON FAN	TAG	WEIGHT	ITEM	SIZE
1	# 1	KEF-1	41 LBS	Curb	23.000"W x 23.000"L x 24.000"H Ver
2	# 2	KMUA-1	29 LBS	Curb	21.000"W x 21.000"L x 14.000"H

FAN #2 A1-G10D - SUPPLY FAN (KMUA-1)

1. DIRECT DRIVE UNTEMPERED SUPPLY UNIT WITH 10' BLOWER IN SIZE #1 HOUSING WITH SPEED CONTROL, DISCONNECT SWITCH.
2. INTAKE HOOD WITH EZ FILTERS
3. DOWN DISCHARGE - AIR FLOW RIGHT -> LEFT
4. ECM WIRING PACKAGE FOR SUPPLY MOTORS WITH PWM SIGNAL FROM ECPM03 PREWIRE.

\*NOTE: SUPPLY DUCT MUST BE INSTALLED TO MEET SMACNA STANDARDS. A MINIMUM STRAIGHT DUCT LENGTH MUST BE MAINTAINED

*Fire System Information - Job#3955543*

FIRE SYSTEM NO.	Tag	TYPE	SIZE	FLOW POINTS	INSTALL
					SYSTEM
1		Ansul R102	3.0	11	Fire Cabinet Right

*GAS VALVE(S)*

FIRE SYSTEM NO.	TAG	TYPE	SIZE	SUPPLIED BY
1		Mechanical	1.500	CaptiveAire Systems

*Fire System Parts List Key*

FIRE SYSTEM NO.	TAG	KEY NUMBER - PART DESCRIPTION
1		0 - 0 - 43-15733 AIR CYLINDER ASSEMBLY - Air Cylinder and Tubing for Mechanical Valves (Ansul Part #15733)
		0 - 0 - Tank Strap Tank Strap - used for ANSUL Tanks
		0 - 0 - UCTANKBRACKET Tank Bracket for fire system tank installation in utility
		1 - 1 - AT - 3.0 TANK(#1B) - 3.0 Gallon SS Tank (for use with Automan Release, Ac or SS Enclosure (UL/ULC)) Macola # 01-429862
		3 - 3 - ANS-DEM REGULATED RELEASE - Ansul Regulated Mechanical Release/Bracke DEM, R-102, Cartridge Detection Included, Ansul Part # 79493
		5 - 5 - LIQ-3.0 AGENT - Ansulex Low PH Wet Chemical Agent, 3 Gallon (UL) 79372
		7 - 7 - 101-20 CARTRIDGE - Carbon Dioxide 101-20, 3 Gallon Cartridge (R-102)
		10 - 10 - TLINK LINK - Test Link (1 test link) Ansul Part # 24916, Macola # 20-24
		11 - 11 - MICRO-SDA MICROSWITCH KIT- Includes 2 switches and Mounting Hardware. Dual Electric Switch, One Standard Switch, One Alarm Duty Switch Ansul Part # 43 Macola # 08-437155
		27 - 27 - QPSA-1/2 PULLEY SEAL - 1/2" Hood Seal (UL) Ansul Part # 423253, Maco # 32-79768
		34 - 34 - RPS-A REMOTE PULL STATION - Red composite (without wire rope) 434618 Macola #06-4835)
		35 - 35 - PE-LT PULLEY ELBOW - Low Temp. Pulley Elbow, Set Screw Type Ansul P # 415670, Macola # 11-415671
	36 - 36 - PE-HT PULLEY ELBOW - High Temp Pulley Elbow, Compression Type, Ansul # 423251, Macola # 10-45771	

**DuctWork #1 Parts - Job#3955543**

Tag	Part #	CFM	S.P.	Weight	Velocity	QTY	Description
P1	DW1245ASY	1332	-0.0473	5.86	1695.96	1	Single Wall Duct 45 Degree
P2	DW1207LT	1332	-0.0035	3.11	1695.96	1	Single Wall Duct 12' diame
P3	DW1217LT	1332	-0.0085	7.05	1695.96	1	Single Wall Duct 12' diame
P4	DW1245ASY	1332	-0.054	5.86	1695.96	1	Single Wall Duct 45 Degree
P5	DW1229LT	1332	-0.0144	11.69	1695.96	1	Single Wall Duct 12' diame
P6	DW1230AJDKIT	1332	-0.0096	15.04	1695.96	1	Single Wall Duct Adjustable Collar - Staln
P7	DW1912TP	1332	0	6.27	1695.96	1	Duct to Curb Transition, BDU11, DUE5, 30 & 33.
Assembled w/P6 System at P7		1332	-0.7583				
	3M-2000PLUS			0.80		2	Duct - 3M Fire Barrier 20
	DW12CLASY			1.23		6	Duct 'V' Clamp With new
<b>Total Weight</b>				<b>63.86</b>			

**SINGLE WALL FACTORY BUILT DUCTWORK**

- ALL DUCTWORK IS REQUIRED TO BE INSTALLED WITH THE MAXIMUM SUPPORT SPACING LISTED BELOW.
- FOR A COMPLETE LIST OF APPROVED SUPPORT METHODS, SEE THE INSTALLATION AND OPERATION MANUA
- DUCTWORK SHALL SLOPE NOT LESS THAN 1/16' PER LINEAR FOOT TOWARDS THE HOOD OR AN APPROVEI
- WHERE HORIZONTAL DUCTS EXCEED 75 FEET IN LENGTH, THE SLOPE SHALL NOT BE LESS THAN 3/16' F

DUCT DIAMETER	HORIZONTAL SUPPORT (ft)	VERTICAL WALL SUPPORT (ft)
8'	10'	10'
10'	10'	10'
12'	10'	10'
14'	10'	10'
16'	10'	10'
18'	10'	10'
20'	10'	10'

**EXHAUST FAN INFORMATION - Job#3865543**

FAN UNIT NO.	TAG	FAN UNIT MODEL #	CFM	ESP.	RPM	HP.	B.H.P.	#	VOLT.	FLA	DISCHARGE VELOCITY	WEIGHT (LBS.)	SONES
1	KEY-1	DAWHFA	1330	1.000	1107	1.000	0.3200	1	115	10.0	400 FPM	92	10.2

**MVA FAN INFORMATION - Job#3865543**

FAN UNIT NO.	TAG	FAN UNIT MODEL #	BLOWER HOUSING	MIN CFM	DESIGN CFM	ESP.	RPM	HP.	B.H.P.	#	VOLT.	FLA	WEIGHT (LBS.)	SONES	
2	KXMA-1	AI-G10	G100	AI	0	1066	0.500	810	1.000	0.4230	1	115	10.0	212	15.9

**FAN OPTIONS**

FAN UNIT NO.	TAG	OPTION (Qty. - Brackets)
1	KEY-1	1 - Grease Box
1	KEY-1	1 - ECH Wiring Package-Exhaust - PWM Signal From ECPH03 Prewire (NIBEC Motor)
2	KXMA-1	1 - ECH Wiring Package-Supply - PWM Signal From ECPH03 Prewire (NIBEC Motor)

**FAN ACCESSORIES**

FAN UNIT NO.	TAG	EXHAUST	SUPPLY
1	KEY-1	GREASE CURB GRAVITY MOUNT WALL DISCHARGE	GRAVITY MOUNT NOTORIZED WALL MOUNT
2	KXMA-1		

**CURB ASSEMBLIES**

NO.	ON FAN	TAG	WEIGHT	ITEM	SIZE
1	# 1	KEY-1	41 LBS	Curb	23,000"V x 23,000"V Vented Hinged
2	# 2	KXMA-1	29 LBS	Curb	21,000"V x 21,000"V x 14,000"V

FAN #2 AI-G10 - SUPPLY FAN (MVA-1)  
 1. DIRECT DRIVE UNIMOUNTED SUPPLY UNIT WITH 10" BLOWER IN SIZE AI HOUSING WITH SPEED CONTROL, DISCONNECT SWITCH.  
 2. INTAKE HOOD WITH EE FILTERS  
 3. DOWN DISCHARGE - AIR FLOW RIGHT -> LEFT  
 4. ECH WIRING PACKAGE FOR SUPPLY MOTORS WITH PWM SIGNAL FROM ECPH03 PREWIRE.  
 MODEL SUPPLY DUCT MUST BE INSTALLED TO MEET DASHIC STANDARDS. A MINIMUM STRAIGHT DUCT LENGTH MUST BE MAINTAINED DOWNSTREAM OF UNIT DISCHARGE AS DETAILED IN ASHA PUBLICATION #10. DO NOT BELT OR UNIT TO DIFFERENT DUCT IN ANY WAY. FAILURE TO PROPERLY SIZE NETWORK MAY CAUSE SYSTEM EFFECTS AND REDUCE PERFORMANCE OF THE EQUIPMENT.  
 SUGGESTED STRAIGHT DUCT SIZE IS 14" x 14"

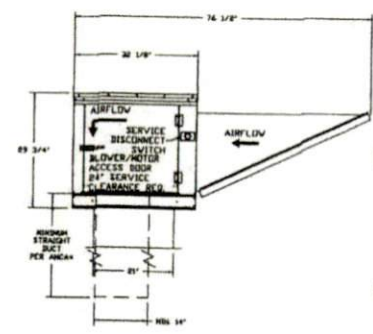
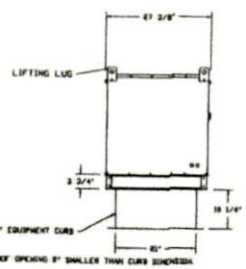
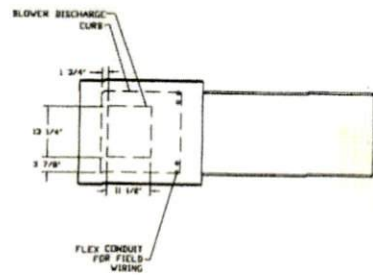

FAN #1 NUMBER - EXHAUST FAN (KEY-1)

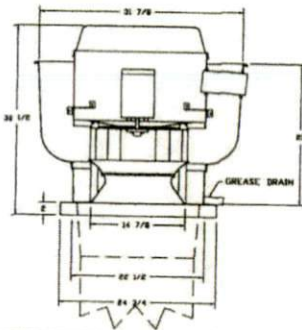

**FEATURES:**

- DIRECT DRIVE CONSTRUCTION ON BOLTS/PALLETS
- ROOF MOUNTED FANS
- RESTAURANT MODEL
- UL30 AND UL70P AND UL-1443
- VARIABLE SPEED CONTROL
- INTERNAL WIRING
- WEATHERPROOF DISCONNECT
- THERMAL OVERLOAD PROTECTION (SINGLE PHASE)
- HEAT HEAT OPERATION 300°F (145°C)
- GREASE CLASSIFICATION TESTING

**NORMAL TEMPERATURE TEST:**  
 EXHAUST FAN MUST OPERATE CONTINUOUSLY WHILE EXHAUSTING AIR AT 300°F (145°C) UNTIL ALL FAN PARTS HAVE REACHED THERMAL EQUILIBRIUM, AND WITHSTAND ANY INTERFERING EFFECTS TO THE FAN WHICH WOULD CAUSE UNSAFE OPERATION.

**ABNORMAL FLAME-UP TEST:**  
 EXHAUST FAN MUST OPERATE CONTINUOUSLY WHILE EXHAUSTING BURNING GREASE VAPORS AT 600°F (316°C) FOR A PERIOD OF 10 MINUTES WITHOUT THE FAN BECOMING DAMAGED TO ANY EXTENT THAT COULD CAUSE AN UNSAFE CONDITION.

**DESIGNS:**

GREASE BOX FOR WIRING PACKAGE-EXHAUST - PWM SIGNAL FROM ECPH03 PREWIRE (NIBEC MOTOR)

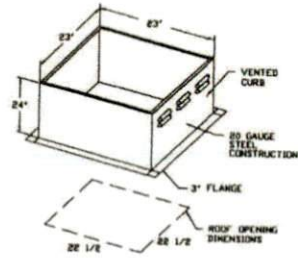

PITCHED CURBS ARE AVAILABLE FOR PITCHED ROOFS.  
 SPECIFY PITCH. EXAMPLE: 7/12 PITCH = 30° SLOPE

**GREASE DUCT & CHIMNEY SPECIFICATIONS:**  
 PROVIDE GREASE DUCT EQUAL TO CAPTIVEAIRE SYSTEMS MODEL 'DW' ROUND 20 GAUGE 430 STAINLESS STEEL DUCTWORK. MODEL 'DW' IS LISTED TO UL-1978 AND IS INSTALLED USING 'V' CLAMP LOCKING CONNECTIONS SEALED WITH 3M FIRE BARRIER 2000 PLUS. MODEL 'DW' DOES NOT REQUIRE WELDING PROVIDING IT HAS BEEN INSTALLED PER THE MANUFACTURERS INSTALLATION GUIDE.  
 PROVIDE RATED ACCESS DOORS AT EVERY CHANGE IN DIRECTION AND EVERY 12' ON CENTER. PER MANUFACTURERS LISTING MODEL 'DW' HORIZONTAL RUNS LESS THAN 75 FT. CAN BE SLOPED 1/16" PER 12", HORIZONTAL RUNS MORE THAN 75 FT. CAN BE SLOPED 3/16" PER 12". DUCT SHOULD BE SLOPED AS MUCH AS POSSIBLE TO REDUCE THE CHANCE OF GREASE ACCUMULATION IN HORIZONTAL RUNS.  
 IF THE DUCT OR CHIMNEY IS WITHIN 18 INCHES OF COMBUSTIBLE MATERIAL, PROVIDE UL-2221 OR UL-103 HT LISTED DOUBLE WALL GREASE DUCT OR DOUBLE WALL CHIMNEY EQUAL TO CAPTIVEAIRE SYSTEMS MODEL 'DW- 2R, 2R TYPE HT, 3R, OR 32" ROUND 20 GAUGE 430 STAINLESS INNER DUCT INSULATED WITH A 24 GAUGE 430 STAINLESS OUTER SHELL.

**CUSTOMER APPROVAL TO MANUFACTURE:**

Approved as Noted   
 Approved with NO Exception Taken   
 Review and Reconnect   
 SIGNATURE \_\_\_\_\_  
 Your Title \_\_\_\_\_ Date \_\_\_\_\_

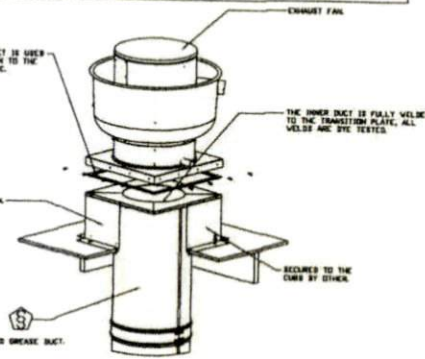

**ELECTRICAL PACKAGE - Job#3955543**

NO.	TAG	PACKAGE #	LOCATION	SWITCHES		OPTION
				LOCATION	QUANTITY	
1		DCV-1111	Utility Cabinet Right	04 - Utility Cabinet Right	1 Light	Smart Controls DC
				Hood # 1	1 Fan	

JOB NO <b>3955543</b>	MODEL NUMBER <b>DCV-1111</b>	DRAWN BY	SCHEMATIC TYPE <b>INSTALL</b>	DESCRIPTION OF OPEP Demand Control Ventilation, w/ contr modulate based on duct temperature sensor shipped loose for field instal distance exceeds 50 feet.
	JOB NAME <b>8th Street Cafe and Deli</b>	DATE 8/23/2019	DWG NO ECP #1-1	

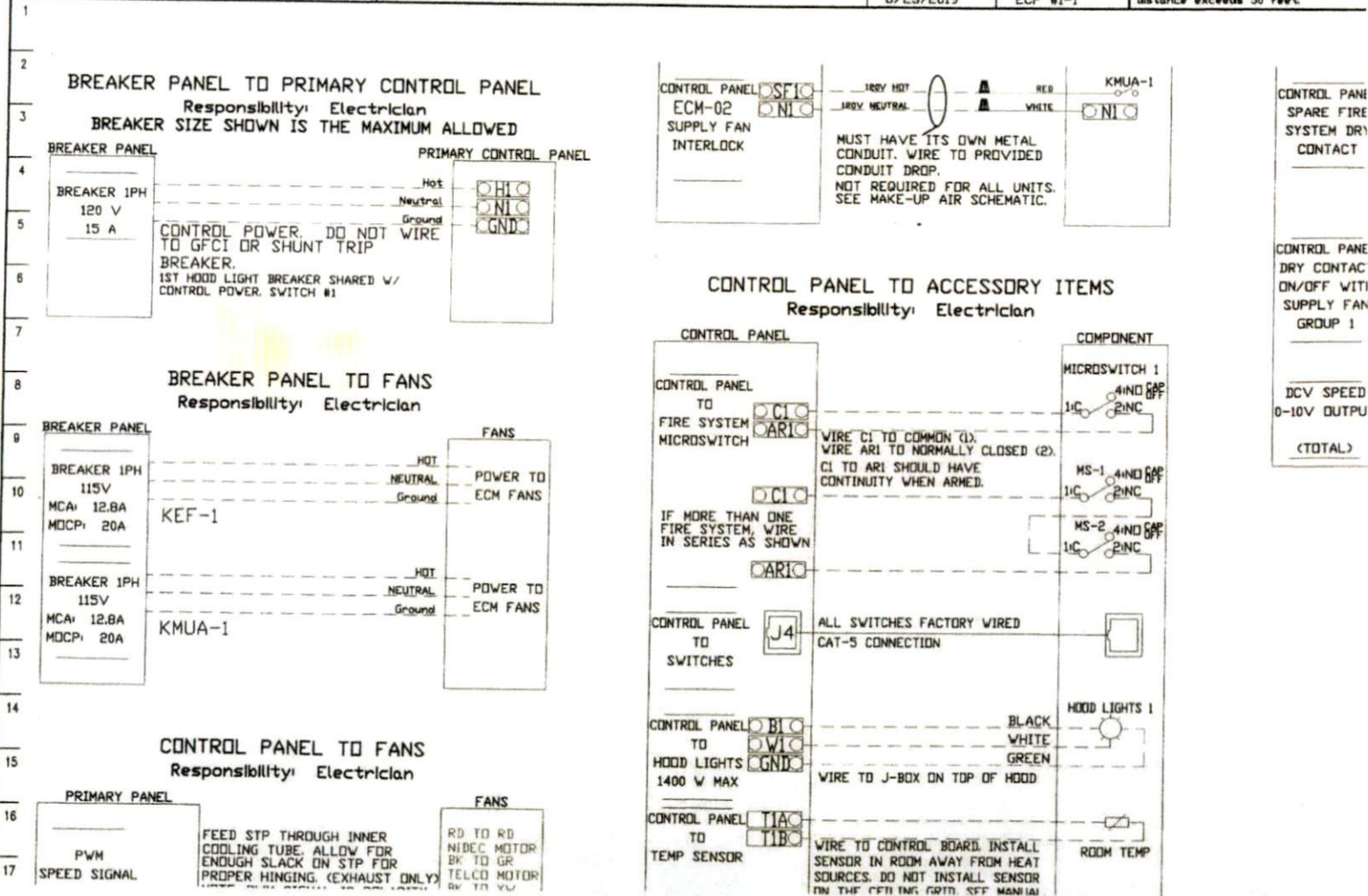

### Demand Control Ventilation Hood Control Panel Specifications:

- Controls shall be listed by ETL (UL 508A) and shall comply with demand ventilation turndown requirements outlined in IECC 403.2.8 (2015).
- The control enclosure shall be NEMA 1 rated and listed for installation inside of the exhaust hood utility cabinet. The control enclosure may be constructed of stainless steel or painted steel.
- Temperature probe(s) located in the exhaust duct riser(s) shall be constructed of stainless steel.
- A digital controller shall be provided to activate the hood exhaust fans dynamically on a fixed differential between the ambient and duct temperature sensors. This shall meet the requirements of IMC 507.1.1.
- A digital controller shall provide adjustable hysteresis settings to prevent cycling fans after the cooking appliances have been turned off and/or the heat in the system is reduced.
- A digital controller shall provide an adjustable minimum fan run-time setting to prevent cycling.
- Variable Frequency Drives (VFDs) shall be provided for fans as required. The digital controller shall modulate the VFDs between a minimum setpoint and a maximum setpoint based on demand. The duct temperature sensor input(s) to the digital controller shall be used to calculate the speed reference signal.
- The VFD speed range of operation shall be from 0% to 100% for the system, with minimum speed set as required to meet minimum ventilation requirements.
- An internal algorithm to the digital controller shall modulate supply fan VFD speed proportional to all exhaust fans that are located in the same fan group as the demand fan.
- The system shall operate in PREP MODE during light cooking load or COOL DOWN MODE when sufficient heat remains underneath the hood system after cooking operations have been completed. Operation during either of these periods will disable the supply fans and set an exhaust fan speed that is equal to the minimum ventilation requirement.
- A digital controller shall disable the supply fan(s), activate the exhaust fan(s), activate the appliance shunt trip, and disable an electric gas valve automatically when fire is detected on a covered hood.

surface, rust-resistant, easy-to-install and clean. Code approved, meets ANSI Z124.1.2, IAPMO listed and Warnock Hersey. 20-in wide by 24-in deep by 35-in high, and includes pull out faucet, supply lines (2), and p-trap.

- Deep 13-in bowl
- Holds 18 gallons per bowl

CA Residents: Prop 65 WARNING(S)

## Specifications

<b>Type</b>	Utility tub	<b>Mounting Hardware Included</b>	
<b>Mount Type</b>	Freestanding	<b>Legs Included</b>	
<b>Material</b>	Polypropylene	<b>Drain Included</b>	
<b>Color/Finish Family</b>	White	<b>Faucet Included</b>	
<b>Manufacturer Color/Finish</b>	White	<b>Items Required for Assembly</b>	Phillips screwdriver, wrench, level and drill
<b>Number of Basins</b>	1	<b>UL Safety Listing</b>	
<b>Length (Inches)</b>	24	<b>CSA Safety Listing</b>	
<b>Width (Inches)</b>	20	<b>ETL Safety Listing</b>	
<b>Assembled Height (Inches)</b>	34	<b>NSF Safety Listing</b>	
<b>Depth of Bowl 1 (Inches)</b>	13	<b>IAPMO/UPC Listing</b>	
<b>Depth of Bowl 2 (Inches)</b>	0	<b>Professional Installation Recommended</b>	
<b>Depth of Bowl 3 (Inches)</b>	0	<b>Warranty</b>	1-year limited
<b>1-Hole Faucet Compatible</b>		<b>Max Flow Rate</b>	2.5 GPM (9.5 LPM)
<b>2-Hole Faucet Compatible</b>		<b>Sink Gauge</b>	N/A
<b>3-Hole Faucet Compatible</b>		<b>Commercial/Residential</b>	Residential
<b>Weight (lbs.)</b>	24	<b>CA Residents: Prop 65 Warning(s)</b>	

Exhaust Fan Wiring		JOB	3955543 - 8th Street Cafe and Deli
DRAWING NUMBER	EXH3955543-1	SHIP DATE	8/23/2019
		MODEL	DU86HFA

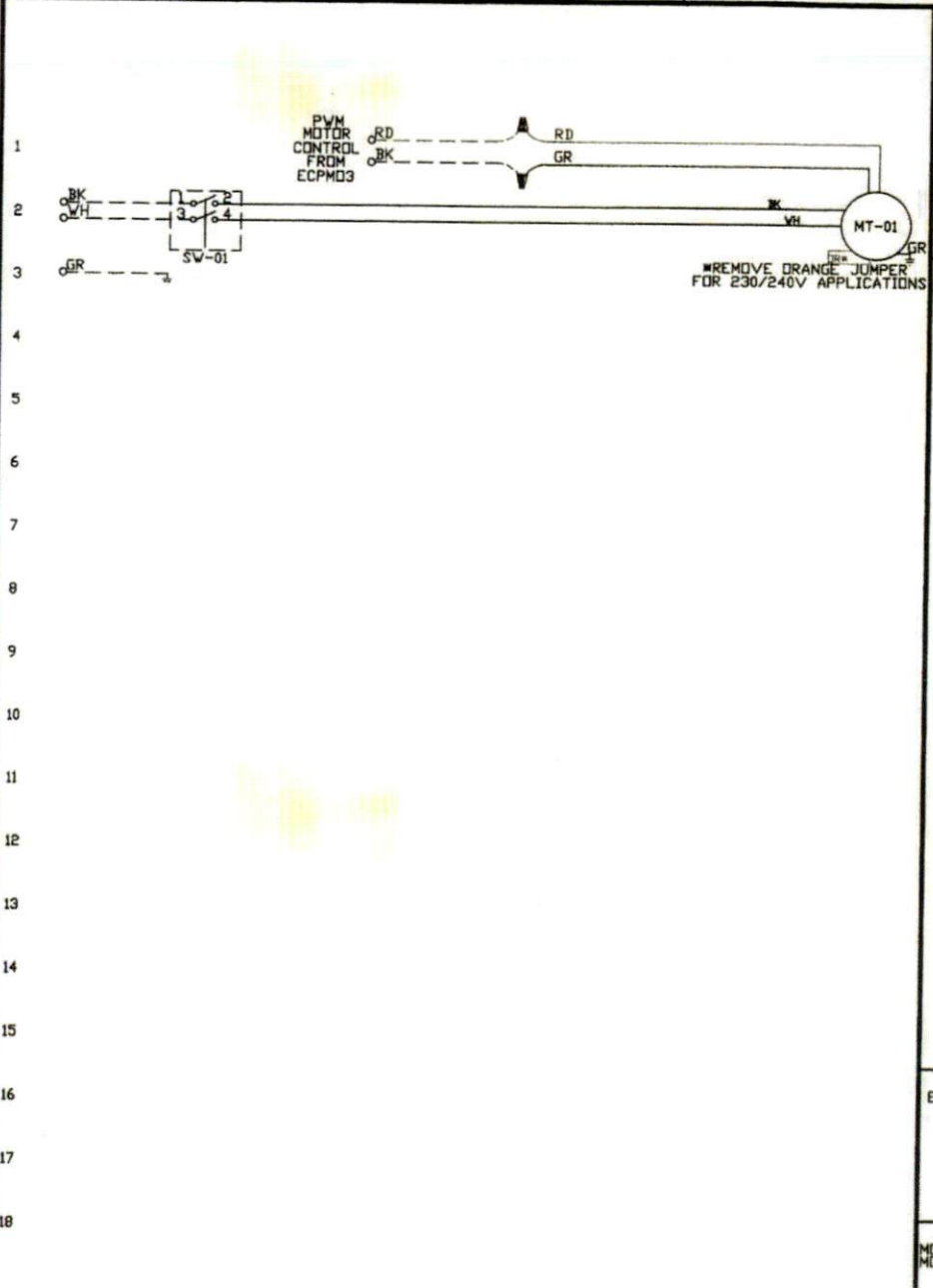

Installed Options

Component Identification		
Label	Description	Location
MT-01	Fan Motor	[2]
MT-02	Damper Motor	[2]
SW-01	Main disconnect switch	[2]

MOTOR INFO  
EXHAUST 1HP-115V-1P-10.2FLA

ELECTRICAL INFORMATION  
MOTOR/CTRL MCA 12.8A  
MOTOR/CTRL MOP 20A

AirHand	
DRAWING NUMBER	
ATTENTION ELEMENT DROP FOR DISCONNECT IS FACTORY SUPPLY CONNECT POWER	
1	
2	BK WH
3	GR
4	
5	
6	
7	
8	
9	
10	
11	
12	
13	
14	
15	
16	
17	
18	



# Amana® Commercial Microwave RMS Series | Low Volume

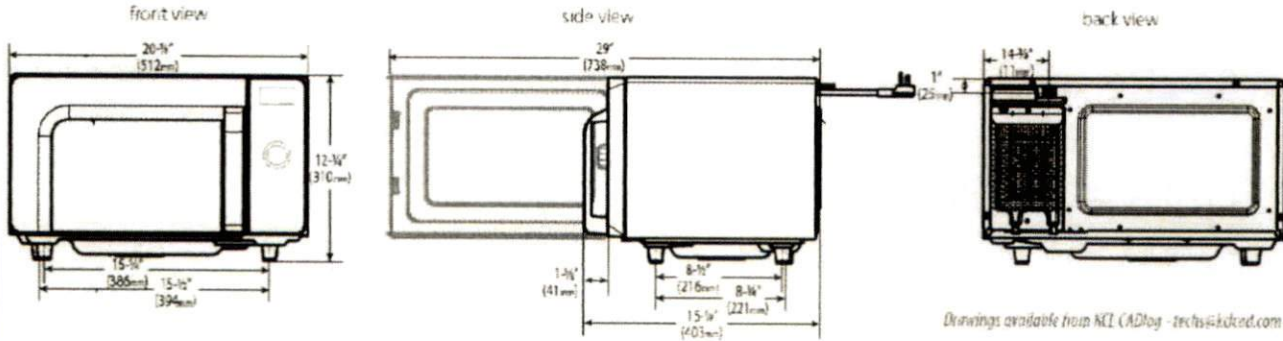

Dimensions			
Exterior	H 12 1/4" (310)	W 20 1/4" (512)	D† 15 1/4" (403)
Cavity	H 7 3/4" (197)	W 13" (330)	D 13" (330)
Usable Cavity Space	0.8 cubic ft. (23 liter)		
Door Depth	29" (738), 90°+ door open		
Installation Clearances	Top: 7" (177.8)	Sides: 1" (25)	Back: None
Shipping Carton	H 15" (381)	W 23" (584)	D 18" (457)
Weight			
Product Weight	Ship weight (approx.)	UPS Shippable	
30 lbs. (13.6 kg.)	37 lbs. (16.8 kg.)	Yes	

Features	Touch Models (TS)	Dial Models (DS)
	Configuration	Countertop
Stackable	No	No
Display	LED	Lighted Dial
Control System	Touchpad	Dial
Programmable Control	Yes, 10 pads	No
Braille	Overlay available	No
Settings Programmable	20	-
Max. Cooking Time	30:00	6:00
Microwave Distribution	Rotating stirrer, bottom	Rotating stirrer, bottom
Power Levels	5	1
Defrost	Yes, 20% power	No
Time Entry Option	Yes	Yes
Multiple Portion Setting	Yes, X2	No
Stage Cooking	4 stages	1 stage
Interior Light	Yes, LED, 42lm	Yes, LED, 42lm
Automatic Voltage Sensor	No	No
Air Filter	No	No
Signal	End of cycle, adjustable	End of cycle
Door Handle	Grab & Go	Grab & Go
Exterior Finish	Stainless steel	Stainless steel
Interior Finish	Stainless steel	Stainless steel

## Optional Accessories

- Oven cavity shelf (SE10)
- Non-stick baskets (TB10/S, SB10/S, MB10/S)
- Stainless cart/equipment stands: (CA24, CA30)

Measurements are US Standard. Measurements in ( ) are in millimeters.  
 \* IEC 60705 Tested  
 † includes handle

## Electrical Configuration

Region	Model#/UPC	Control System	Power Consumption	Power Output (microwave)	Power Source	Plug Configuration	Cord Length	Frequency	Magnetron
North America single phase	RMS10TSA 728028470208	Touch	1500 W, 13A	1000 W*	120 V, 60 Hz, 15 A, single phase	NEMA 5-15	5 ft. (1.5m)	2450MHz	1
North America single phase	RMS10DSA 728028470239	Dial	1500 W, 13A	1000 W*	120 V, 60 Hz, 15 A, single phase	NEMA 5-15	5 ft. (1.5m)	2450MHz	1

**ACP** 225 49th Ave. Dr SW Cedar Rapids IA 52404 USA  
 800-233-2765 • 319-368-8120 • Fax 319-368-8198  
 www.acpsolutions.com

Part No. 20271-01  
 Updated 06/07/2019  
 © 2019 ACP, Inc., Cedar Rapids, Iowa 52404

an Ali Group Company



The Spirit of Excellence

Specification B

AMA Title 9

Item # 398954 Model  
# 19CFP

## Mustee 20-in x 24-in White Freestanding Polypropylene Utility Sink with Drain and Faucet

156 Ratings  
4.0 Average

81%  
Recommend  
this  
product

Community  
Q&A  
[View Now](#)



 Max Flow Rate: 2.5 GPM (9.5 LPM)



Get 5% OFF\* EVERY DAY or 6 Months Special Financing\*\*

\*\*Offer subject to credit approval and cannot be combined with other credit offers.  
Minimum purchase required. Exclusions apply.

[GET DETAILS](#)

# \$139.00

- Complete with faucet, 2 supply lines, and 1.5-in p-trap
- 1 piece molded laundry tub floor mounted
- 20-in W x 24-in D x 34-in H

**FREE Store  
Pickup**

3 available today  
at N. Fayetteville  
Lowe's!

**Aisle 43 , Bay 13**

**Shipping &  
Delivery**

Available!

## Product Information

### Description

Heavy duty/sturdy, one-piece molded single laundry tub. Heavy gauge steel legs, includes levelers and stoppers. 13-in deep leak proof 1-1/2-in integral molded drain. Smooth white

- Complete with faucet, 2 supply lines, and 1.5-in p-trap
- 1 piece molded laundry tub floor mounted
- 20-in W x 24-in D x 34-in H

Model:

TSSU-48-18M-B-HC

### Food Prep Table:

Mega-Top Solid Door Sandwich/Salad Unit with Hydrocarbon Refrigerant



## STANDARD FEATURES

### DESIGN

- True's commitment to using the highest quality materials and oversized refrigeration systems provides the user with colder product temperatures, lower utility costs, exceptional food safety and the best value in today's food service marketplace.

### REFRIGERATION SYSTEM

- Factory engineered, self-contained, capillary tube system using environmentally friendly R290 hydrocarbon refrigerant that has zero (0) ozone depletion potential (ODP), & three (3) global warming potential (GWP).
- Energy efficient, factory balanced refrigeration system with guided airflow to provide uniform temperature in food pans and cabinet interior.
- Patented forced-air design holds 33°F to 41°F (5°C to 5°C) product temperature in food pans and cabinet interior. Complies with ANSI/NSF-7.
- Sealed, self-lubricating evaporator fan motor and larger fan blades give True sandwich/salad units a more efficient, low velocity, high volume airflow design.
- Condensing unit access in back of cabinet, slides out for easy maintenance.

### CABINET CONSTRUCTION

- Exterior - stainless steel front, top and ends. Corrosion resistant GalFan coated steel back.
- Interior - attractive, NSF approved, clear coated aluminum liner. Stainless steel floor with coved corners.
- Insulation - entire cabinet structure and solid doors are foamed-in-place using a high density, polyurethane insulation that has zero ozone depletion potential (ODP) and zero global warming potential (GWP).
- 5" (127 mm) diameter stem castors - locks provided on front set. 36" (915 mm) work surface height.

### DOORS

- Stainless steel exterior with clear aluminum liner to match cabinet interior.
- Each door fitted with 12" (305 mm) long recessed handle that is foamed-in-place with a sheet metal interlock to ensure permanent attachment.
- Positive seal self-closing doors with 90° stay open feature. Doors swing within cabinet dimensions.
- Magnetic door gaskets of one piece construction, removable without tools for ease of cleaning.

### SHELVING

- Four (4) adjustable, heavy duty PVC coated wire shelves 21 1/8" L x 16" D (548 mm x 407 mm). Four (4) chrome plated shelf clips included per shelf.
- Shelf support plasters made of same material as cabinet interior; shelves are adjustable on 1/2" (13 mm) increments.

### MODEL FEATURES

- Evaporator is epoxy coated to eliminate the potential of corrosion.
- 8 7/8" (226 mm) deep, 1/2" (13 mm) thick, full length removable cutting board. Sanitary, high-density, NSF approved white polyethylene provides tough preparation surface.
- Stainless steel, patented, foam insulated lid and hood keep pan temperatures colder, lock in freshness and minimize condensation. Removable for easy cleaning.
- Comes standard with 18 (1/2 size) 6 7/8" L x 6 1/4" W x 4" D (175 mm x 159 mm x 102 mm) clear polycarbonate, NSF approved, food pans in countertop prep area. Also accommodates 6" (153 mm) deep food pans (supplied by others).
- Countertop pan opening designed to fit varying size pan configurations with available pan divider bars. Varying size pans supplied by others.
- NSF/ANSI Standard 7 compliant for open food product.

### ELECTRICAL

- Unit completely pre-wired at factory and ready for final connection to a 115/60/1 phase, 15 amp dedicated outlet. Cord and plug set included.



115/60/1  
NEMA-5-15R

### OPTIONAL FEATURES/ACCESSORIES

Upcharge and lead times may apply.

- 230 - 240V / 50 Hz.
- 6" (153 mm) standard legs.
- 6" (153 mm) seismic/flanged legs.
- 2 1/2" (64 mm) diameter castors.
- Barrel locks (factory installed). Requires one per door.
- Additional shelves.
- Single overshelf.
- Double overshelf.
- Flat lid.
- Sneezeguard.
- 8 7/8" (226 mm) deep, 1/2" (13 mm) thick, composite cutting board.
- Crumb catcher. Requires crumb catcher cutting board for proper installation.
- Pan dividers.
- Exterior rectangular digital temperature display (factory installed).
- ADA compliant model with 34" (864 mm) work surface height.

## PLAN VIEW

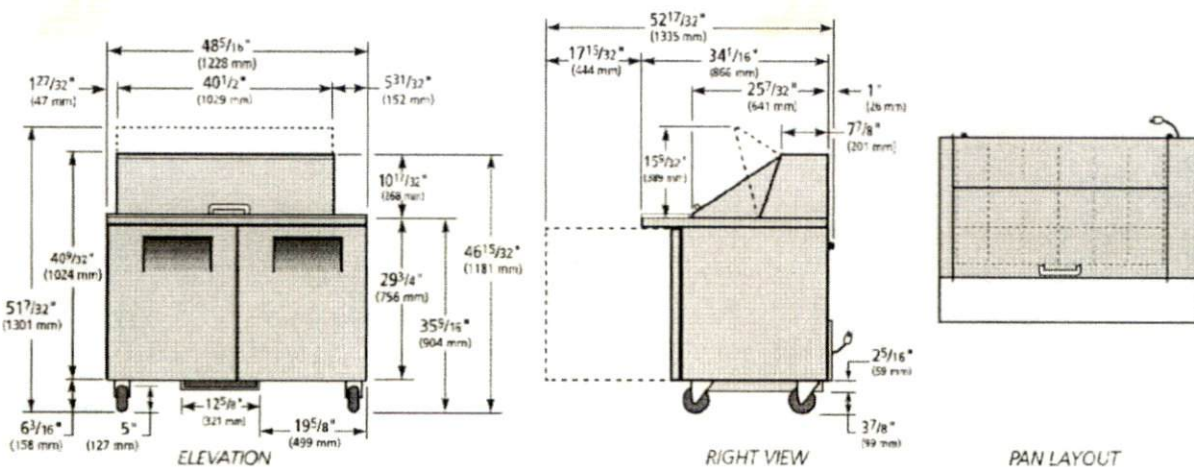

### WARRANTY

Three year warranty on all parts and labor and an additional 2 year warranty on compressor. (U.S.A. only)

METRIC DIMENSIONS ROUNDED UP TO THE NEAREST WHOLE MILLIMETER

SPECIFICATIONS SUBJECT TO CHANGE WITHOUT NOTICE



Model	Elevation	Right	Plan	3D	Back
TSSU-48-18M-B-HC	TFNY44E	TFNY42S	TFNY44P	TFNY443	

## TRUE MANUFACTURING CO., INC.

2001 East Terra Lane • O'Fallon, Missouri 63366-4434 • (636)240-2400 • Fax (636)272-2408 • Toll Free (800)325-6152 • Intl. Fax# (001)636-272-7546 • www.truemfg.com

# Amana® Commercial

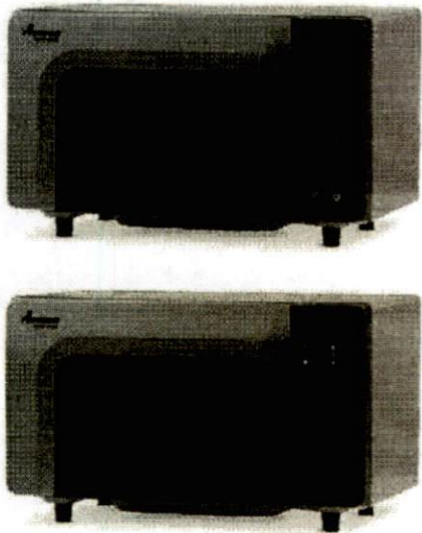

Project #: \_\_\_\_\_

Item #: \_\_\_\_\_

## Low Volume Amana® Commercial Microwave RMS Series

### Power Output

- 1000 watts of power
- Perfect replacement for inappropriate domestic ovens used in foodservice applications

### Available with Touch or Dial Controls

- **Touch controls:**
  - 20 programmable menu items simplifies cooking
  - 5 power levels and 4 cooking stages for cooking flexibility
  - Multiple quantity pad calculates the proper cooking times for multiple portions
- **Dial Controls:**
  - Timer automatically resets to zero if door is opened during heating
  - 6 minute digital timer lights up for "at-a-glance" monitoring
  - Full power only for simple operation

### Easy to Use

- See-through door and lighted interior for monitoring without opening the door
- 0.8 cubic foot (23 liter) capacity accommodates a 12" (305mm) platter, prepackaged foods and single servings

### Certified Oven for Commercial Applications

- Tested to higher standards for a commercial rating — required by most commercial insurance policies and health inspectors
- Interlock safety switch is tested to 4 times the standard of residential ovens
- Constructed to withstand the foodservice environment, multiple users and variable ambient temperatures
- Compared to a residential oven, this oven is more powerful for faster heating and better quality results
- Engineered for a simple, "self-service" operation

### Easy to Maintain

- Stainless steel exterior wrap, door, and oven interior for increased durability
- Sealed-in Borosilicate Glass shelf for easy cleaning

**Value Line | Low Volume**  
This category of microwave oven is ideal for...

### Applications

- Convenience Stores
- Coffee shops
- Dessert stations
- Teachers/Staff lounge
- Nurses stations
- Vending

### Boost heats and re-therms foods in seconds

- Slice of apple pie re-therms in 20 seconds
- 9 oz. (255g) cup of chili re-therms in 1:45

All ACP, Inc. commercial ovens are supported by our Culinary Center. Do not hesitate to contact us for any questions regarding food preparation, menu development and cooking times: [yourkitchen@acpsolutions.com](mailto:yourkitchen@acpsolutions.com)



### Service

All products are backed by the ACP, Inc. 24/7 ComServ Support Center



### Warranty

Warranty Certificate for this product can be found on the ACP, Inc. website at [www.acpsolutions.com/warranty](http://www.acpsolutions.com/warranty)



### Safety and Sanitation

This ACP, Inc. product meets and exceeds safety and sanitation standards set for commercial microwave ovens by UL, ETL, NSF, CSA, and FDA.



AIA File #

Specification #



©2019 ACP, Inc.  
Cedar Rapids, Iowa 52401

225 49th Ave. Dr. SW Cedar Rapids, IA 52404 USA

800-233-2366

319-369-8120

Fax: 319-369-8193

[www.acpsolutions.com](http://www.acpsolutions.com)

Amana is a trademark of Maytag Properties, LLC or its related companies. Manufactured under license by ACP, Inc. Limited warranty provided by manufacturer. © 2019 ACP, Inc.

# Specifications

Micro Matic reserves the right to change specifications without notice. **AUTOQUOTES**

Part No.	Exterior Finish	Lids	Shipping Weight	Box Dimensions
<input type="checkbox"/> <b>MDW95</b>	Black	3	231 kg 508 lbs	2413mm L x 712mm W x 839mm H 95 3/8"L x 28"W x 33 3/8"H
<input type="checkbox"/> <b>MDW95S</b>	Stainless Steel	3	231 kg 508 lbs	2413mm L x 712mm W x 839mm H 95 3/8"L x 28"W x 33 3/8"H

# Operating Performance

<b>Capacity</b>	58.7 cases (12 oz can) 43.2 cases (12 oz bottle)	<b>Condenser HP</b>	1/2
<b>Dividers</b>	7	<b>Running Amps</b>	6.5
<b>Lid Locks</b>	Standard	<b>Voltage</b>	115/60/1
<b>Interior Light</b>	Standard	<b>Plug Type</b>	NEMA-5-15R
<b>Cap Opener/Catcher</b>	Standard	<b>Cord Length</b>	8'
		<b>Refrigerant</b>	R-134a

<b>Exterior</b>	All Models: 18 gauge stainless steel top with raised glass rails. Black Models: Front, sides, and back black vinyl over steel. Stainless Steel Models: Front, sides and back are stainless steel.
<b>Interior</b>	Durable galvanized steel. NSF approved for pre-packaged and bottle products.
<b>Ventilation</b>	Front and side ventilation.
<b>Plumbing</b>	Automatic condensate evaporator, no drain connection required. Evaporator condensate has been plumbed to a condensate pan located in the compressor housing.
<b>Insulation</b>	Foamed-in-place using high density, CFC-free polyurethane; 1-1/2" top, walls and floor.
<b>Accessories</b>	Castors or 6" Fixed Legs

# Dimensions

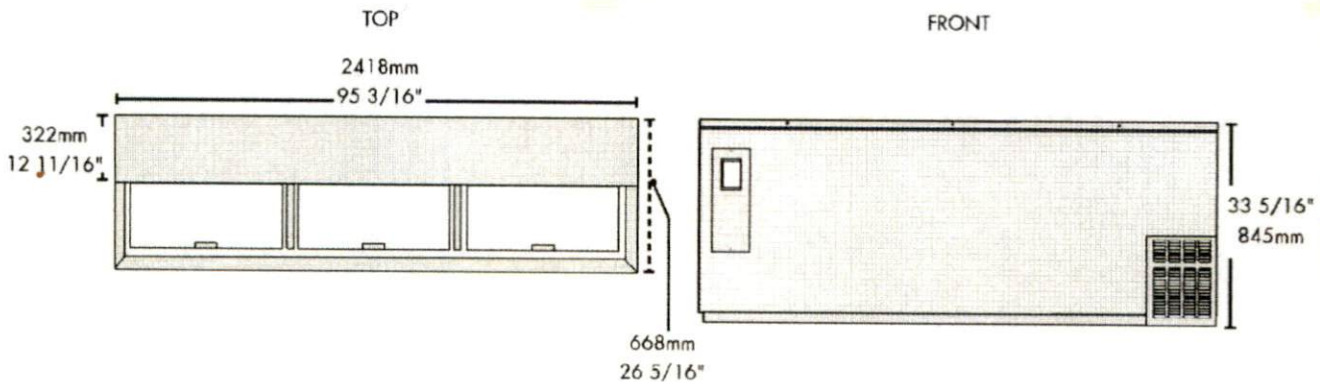

Copyright ©2012 Micro Matic USA, Inc. All Rights Reserved.

00839-003 12



[www.micromatic.com](http://www.micromatic.com)

Toll Free: 1-(866) 327-4159

West	Central	Southeast	Northeast
19791 Bahama Street Northridge, CA 91324 Tel. (818) 701-9765 Fax. (818) 701-9844	10726 North Second Street Machesney Park, IL 61115 Tel. (815) 968-7557 Fax. (815) 968-0363	2364 Simon Court Brooksville, FL 34604 Tel. (352) 799-6331 Fax. (352) 796-2429	4601 Saucon Creek Road Center Valley, PA 18034 Tel. (610) 625-4464 Fax. (610) 625-4466



TRUE MANUFACTURING CO., INC.  
U.S.A. FOODSERVICE DIVISION

2001 East Terra Lane • O'Fallon, Missouri 63366-4434 • (636)240-2400  
Fax (636)272-2408 • Toll Free (800)325-6152 • Int'l Fax# (001)636-272-7546  
Parts Dept. (800)424-TRUE • Parts Dept. Fax# (636)272-9471 • www.truemfg.com

Project Name: \_\_\_\_\_

Location: \_\_\_\_\_

Item #: \_\_\_\_\_ Qty: \_\_\_\_\_

Model #: \_\_\_\_\_

AIA #

SIS #

Model:

TSSU-48-18M-B-HC

**Food Prep Table:**

*Mega-Top Solid Door Sandwich/Salad Unit with Hydrocarbon Refrigerant*



**TSSU-48-18M-B-HC**

- ▶ True's salad/sandwich units are designed with enduring quality that protects your long term investment.
- ▶ Factory engineered, self-contained, capillary tube system using environmentally friendly R290 hydro carbon refrigerant that has zero (0) ozone depletion potential (ODP), & three (3) global warming potential (GWP).
- ▶ Patented forced-air design holds 33°F to 41°F (5°C to 5°C) product temperature in food pans and cabinet interior.
- ▶ Complies with ANSI/NSF-7.
- ▶ All stainless steel front, top and ends. Corrosion resistant GalFan coated steel back.
- ▶ Stainless steel, patented, foam insulated lid and hood keep pan temperatures colder, lock in freshness and minimize condensation. Removable for easy cleaning.
- ▶ Interior - attractive, NSF approved, clear coated aluminum liner. Stainless steel floor with coved corners.
- ▶ 8 1/4" (226 mm) deep, 1/2" (13 mm) thick, full length removable cutting board included. Sanitary, high density, NSF approved white polyethylene provides tough preparation surface.
- ▶ Heavy duty PVC coated wire shelves.
- ▶ Foamed-in-place using a high density, polyurethane insulation that has zero ozone depletion potential (ODP) and zero global warming potential (GWP).

**ROUGH-IN DATA**

Chart dimensions rounded up to the nearest 1/8" (millimeters rounded up to next whole number). Specifications subject to change without notice.

Model	Doors	Shelves	Pans (top)	Cabinet Dimensions (inches) (mm)			HP	Voltage	Amps	NEMA Config.	Cord Length (total ft.) (total m)	Crated Weight (lbs.) (kg)
				W	D†	H*						
TSSU-48-18M-B-HC	2	4	18	48 3/8	34 1/8	40 3/8	1/8	115/60/1	5.8	5-15P	11	310
				1229	867	1026	1/8	230-240/50/1	4.2	▲	3.35	141

† Depth does not include 1" (26 mm) for rear bumpers.

\* Height does not include 6 1/4" (159 mm) for castors or 6" (153 mm) for optional legs.

▲ Plug type varies by country.



6/18-A

Printed in U.S.A.

APPROVALS:

AVAILABLE AT:

DuctWork #1 Parts - Job#396543

Tag	Part #	CFM	S.P.	Weight	Velocity	QTY	Description
P1	DV1825AST	1330	-0.0473	5.86	1695.96	1	Single Valt Duct 45 Degree Elbow, 18" Duct, Assembly.
P2	DV1825LT	1330	-0.0035	3.11	1695.96	1	Single Valt Duct 18" diameter, 2' long, Flange at both ends. Stainless Steel.
P3	DV1825LT	1330	-0.0095	7.25	1695.96	1	Single Valt Duct 18" diameter, 17' long, Flange at both ends. Stainless Steel.
P4	DV1825AST	1330	-0.051	2.86	1695.96	1	Single Valt Duct 45 Degree Elbow, 18" Duct, Assembly.
P5	DV1825LT	1330	-0.0144	5.69	1695.96	1	Single Valt Duct 18" diameter, 8'9" long, Flange at both ends. Stainless Steel.
P6	DV1825ADJKT	1330	-0.0096	10.04	1695.96	1	Single Valt Duct Adjustable, 18" diameter, 23'9" long, Flange at one end WITH a 18" Adjustable Collar - Stainless Steel.
Assembled w/P7 System at P7	DV1818TP	1330	0	6.87	1695.96	1	Duct To Curve Transition, 18-1/2" Curve to 18" Duct, 16 GA Aluminum Steel Used on 2000L, 2005, 20 & 25.
Assembled w/P8 System at P7	SH-6000PLUS			8.80		2	Duct - SH Fire Barrier 2000 Plus Stone - Used as sealant to Seal Duct Joints.
	DV1825LAST			1.23		6	Duct 18" Elbow With new design 14 Ga Brackets, 18" Duct, Assembly.
Total Weight				63.06			

SINGLE WALL FACTORY BUILT DUCTWORK

- ALL DUCTWORK IS REQUIRED TO BE INSTALLED WITH THE MAXIMUM SUPPORT SPACING LISTED BELOW.
- FOR A COMPLETE LIST OF APPROVED SUPPORT METHODS, SEE THE INSTALLATION AND OPERATION MANUAL.
- DUCTWORK SHALL SLOPE NOT LESS THAN 1/16" PER LINEAR FOOT TOWARDS THE HOOD OR AN APPROVED GREASE COLLECTION RESERVOIR.
- WHERE HORIZONTAL DUCTS EXCEED 75 FEET IN LENGTH, THE SLOPE SHALL NOT BE LESS THAN 3/16" PER LINEAR FOOT.

DUCT DIAMETER	HORIZONTAL SUPPORT (Ft)	VERTICAL WALL SUPPORT (Ft)	VERTICAL CURB SUPPORT (Ft)
8"	10'	10'	24'
10"	10'	10'	24'
12"	10'	10'	24'
14"	10'	10'	24'
16"	10'	10'	24'
18"	10'	10'	24'
20"	10'	10'	24'
22"	10'	10'	24'
24"	10'	10'	24'

DuctWork #1 SE View



DuctWork #1 Front View DuctWork #1 Top View DuctWork #1 Side View

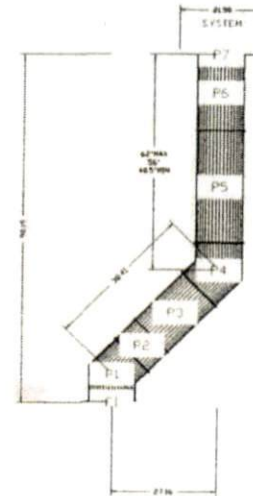
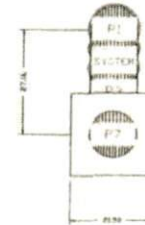
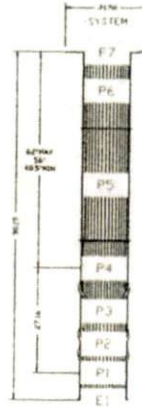

**Step 2: Install the Legs (or Optional Casters) and Restraints**

A set of legs is packed with the fryer. Casters are optional, purchased separately. Mounting fasteners are pre-mounted on the base plates.

1. Raise fryer sufficiently to allow legs or casters to be screwed into the base plate. For safety, "shore up" and support the fryer with an adequate blocking arrangement strong enough to support the load.
2. Screw the four legs or casters to the plate on the bottom of the fryer. When casters have been ordered, the casters having a locking-brake should be attached under the front of the fryer.
3. Lower the fryer gently. Never drop or allow the fryer to fall.
4. Use a level to make sure that the fryer is level. Each caster, or the tubular-end of each leg, can be screwed in or out to lower or raise each corner of the fryer.
5. Attach restraints as required by local codes.

INSTALLATION

**NOTICE**

Unit must be level to assure maximum performance. Improper leveling may void warranty.

**NOTICE**

When this appliance is installed with casters, it must be installed with the casters supplied, a connector complying with either ANSI Z21.69 CSA 6.16 and a quick-disconnect device complying with ANSI Z21.41 CSA 6.9. It must also be installed with restraining means to guard against transmission of strain to the connector, as specified in the appliance manufacturer instructions.

 **WARNING**

If disconnection of the restraint is necessary to move the appliance for cleaning, etc., reconnect it when the appliance is moved to its original installed position.

 **WARNING**

When this appliance is installed with casters, it must be installed with the casters supplied, a connector complying with either ANSI Z21.69 or CAN/CGA-6.16 and a quick disconnect device complying with either ANSI Z21.41 or CAN1-6.9. It must also be installed with restraining means to guard against transmission of strain to the connector, as specified in the appliance manufacturer's instructions.

 **WARNING**

All fryers must be restrained to prevent tipping in order to avoid the splashing of hot liquid. The means of restraint may be the manner of installation.





# INSTALLATION

## NOTICE

Installation must conform with local codes, or in the absence of local codes, with the *National Fuel Gas Code, ANSI Z223.1, Natural Gas Installation Code, CAN/CGA-B149.1*, or the *Propane Installation Code, CAN/CGA-B149.2*, as applicable.

## NOTICE

These installation procedures must be followed by qualified personnel or warranty will be void.

Local codes regarding installation vary greatly from one area to another. The National Fire Protection Association, Inc. states in its NFPA 96 latest edition that local codes are the "authority having jurisdiction" when it comes to installation requirements for equipment.

INSTALLATION

### Step 1: Unpack

#### IMMEDIATELY INSPECT FOR SHIPPING DAMAGE

All containers should be examined for damage before and during unloading. The freight carrier has assumed responsibility for safe transit and delivery. If damaged equipment is received, either apparent or concealed, a claim must be made with the delivering carrier.

Apparent damage or loss must be noted on the freight bill at the time of delivery. The freight bill must then be signed by the carrier representative (Driver). If the bill is not signed, the carrier may refuse the claim. The carrier can supply the necessary forms.

A request for inspection must be made to the carrier within 15 days if there is concealed damage or loss that is not apparent until after the equipment is uncrated. The carrier should arrange an inspection. Be certain to hold all contents plus all packing material.

1. Uncrate carefully. Report any hidden damage to the freight carrier IMMEDIATELY.
2. Do not remove any tags or labels until unit is installed and working properly.

**GAS SUPPLY AND BURNER INFORMATION**

Supply pressure should be minimum of 4" W.C. for natural gas or 10" W.C. for propane. The fryer comes with 3/4" NPT male connector on a 1/2" pipe, allowing you to connect with either 3/4" or 1/2" NPT female connector.

Model	Burners	Gas Type	Manifold Pressure	Number of heat tube	Rate Each BTUs / Hour	Total Rate BTUs / Hour	Orifice Size
GFF35G	Main	Natural	4" W.C.	3	30,000	90,000	#39
GFF35PG		Propane	10" W.C.	3	30,000	90,000	#52
GFF50G	Main	Natural	4" W.C.	4	30,000	120,000	#39
GFF50PG		Propane	10" W.C.	4	30,000	120,000	#52
GFF80G	Main	Natural	4" W.C.	5	30,000	150,000	#39
GFF80PG		Propane	10" W.C.	5	30,000	150,000	#52

\* Minimum supply pressure is 4" W.C. for natural gas and 10" W.C. for propane.  
 \*\* Orifice sizes are for units installed at altitudes between 0 and 2000 feet above sea level.

# SPECIFICATIONS

## DIMENSIONS

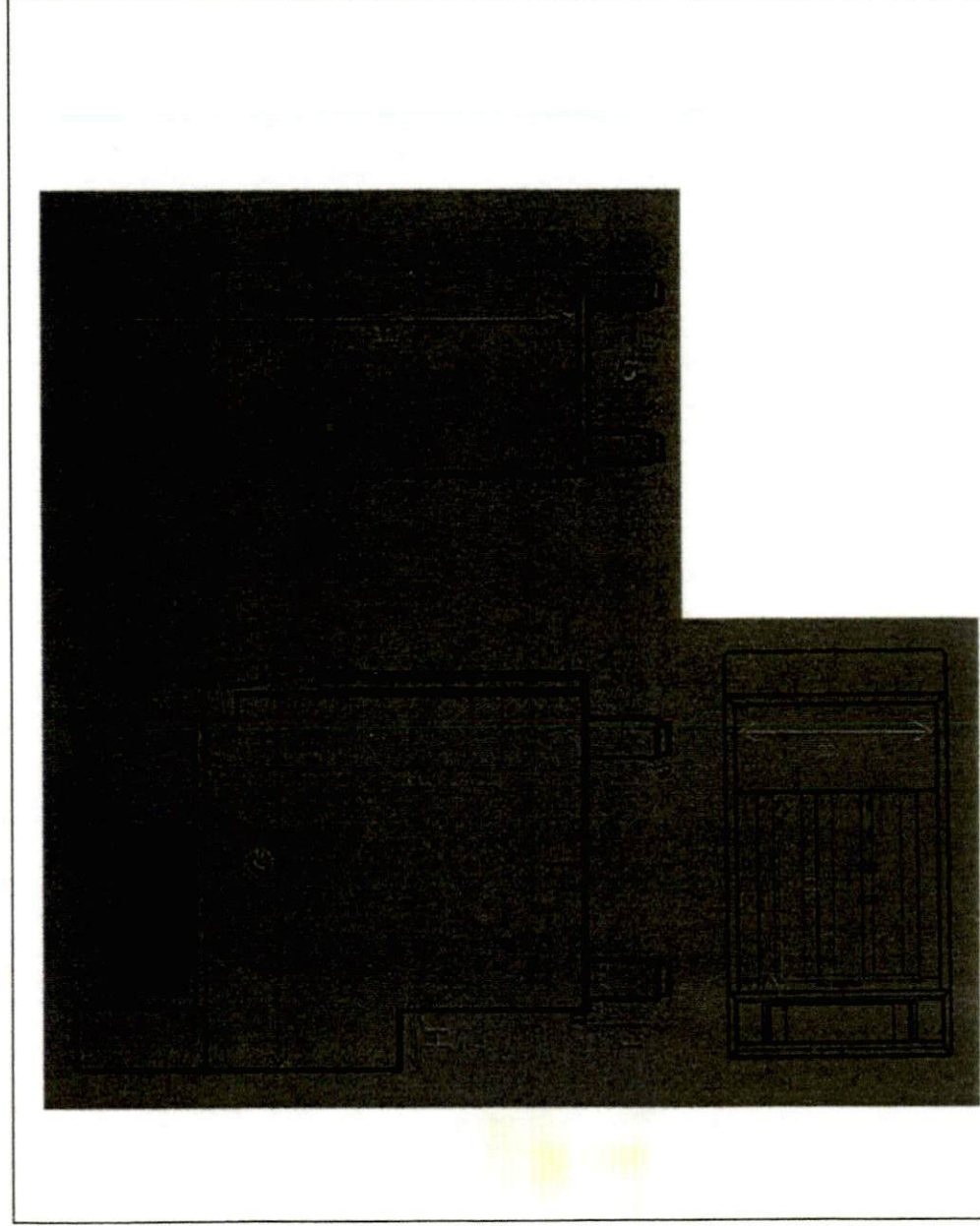

Note: for mm, multiply inches by 25.4

Model	Width (in)			Depth (in)			Height (in)			Gas Connection (in)			Total BTU/hr	Crated Weight (lbs)
	A	B	C	D	E	F	G	H	I	H	I			
GFF35G	15.5	14.0	30.3	14.0	47.2	34.7	6.0	4.2	7.0				90,000	176
GFF35PG														
GFF50G	15.5	14.0	30.3	14.0	47.2	34.7	6.0	4.2	7.0				120,000	192
GFF50PG														
GFF80G	21.0	18.0	34.3	18.0	47.2	34.7	6.0	4.2	7.0				150,000	265
GFF80PG														

# OPERATOR'S MANUAL

## GFF Series Fryers



**Model GFF35G  
GFF35PG**  
(3 Burner Fryer)

**Model GFF50G  
GFF50PG**  
(4 Burner Fryer)

**Model GFF80G  
GFF80PG**  
(5 Burner Fryer)

**! WARNING**

Improper installation, adjustment, alteration, service or maintenance can cause property damage, injury or death. Read the installation, operating and maintenance instructions thoroughly before installing or servicing this equipment.

In order to provide the best service, ATOSA Catering Equipment INC. requests that please register your warranty online at [www.atosausa.com](http://www.atosausa.com) For any service issues, please kindly contact us at  
Email: [warranty@atosausa.com](mailto:warranty@atosausa.com)  
Or  
Toll Free: +1-800-683-8660

## **Gas Countertop Griddles Operating Instructions**

Before you begin, please read these instructions carefully to use this product correctly, to make the product perform ideally, and to avoid hazards.

**Models: ATTG-24 / ATTG-36 / ATTG-48**



4. Wipe off the basket support frame and the inside of the frypot with a clean cloth.

**! CAUTION**

*SOME AREAS OF THE FRYPOT MAY BE HOT!*

5. Close drain valve and strain the oil back into the frypot through several thicknesses of cheesecloth, or filter it back using a filter machine.
6. Replace the basket support frame (if applicable)
7. Add oil or shortening to MIN oil level mark on rear of frypot.
8. To resume cooking, turn the combination gas valve knob to "ON" position.

### WEEKLY CLEANING

1. Follow steps 1 through 4 of the Daily Cleaning procedure (see previous section).
2. Close drain valve and fill frypot with a solution of warm water and boil-out compound
3. Relight the fryer and bring the solution to a gentle boil for at least five minutes.
4. Turn off main burners and let the solution stand until the gum deposits are softened and the carbon spots and burned grease spots can be rubbed off.
5. Scrub the frypot walls and heat tubes, then drain out frypot and rinse it with clean water.
6. Refill the frypot with clean water and boil again.
7. Turn off gas and drain and rinse well until clean.
8. Wipe dry with a clean cloth.
9. Refill as specified in the "Filling the Frypot" section (see page 13).

### MONTHLY CLEANING

1. Perform the Weekly Cleaning procedure (see previous section).
2. Clean around burner and orifices if lint has accumulated.
3. Visually check that burner carry-over ports are unobstructed.

### CLEANING STAINLESS STEEL SURFACES

To remove normal dirt, grease and product residue from stainless steel use ordinary soap and water (with or without detergent) applied with a sponge or cloth. Dry thoroughly with a clean cloth. Never use vinegar or any corrosive cleaner.

To remove grease and food splatter or condensed vapors that have baked on the equipment apply cleanser to a damp cloth or sponge and rub cleanser on the metal in the direction of the polishing lines on the metal. Rubbing cleanser, as gently as possible, in the direction of the polished lines will not mar the finish of the stainless steel. NEVER RUB WITH A CIRCULAR MOTION. Soil and burnt deposits that do not respond to the above procedure can usually be removed by rubbing the surface with SCOTCH-BRITE™ scouring pads or STAINLESS scouring pads. DO NOT USE ORDINARY STEEL WOOL, as any particles left on the surface will rust and further spoil the appearance of the finish. NEVER USE A WIRE BRUSH, STEEL SCOURING PADS (EXCEPT STAINLESS), SCRAPER, FILE OR OTHER STEEL TOOLS. Surfaces that are marred collect dirt more rapidly and become more difficult to clean. Marring also increases the possibility of corrosive attack. Refinishing may then be required.

Darkened areas, called "heat tint," sometimes appear on stainless steel surfaces where the area has been subjected to excessive heat. These darkened areas are caused by thickening of the protective surface of the stainless steel and are not harmful. Heat tint can normally be removed by the above cleaning techniques, but tint which does not respond to that procedure calls for a vigorous scouring in the direction of the polish lines, using SCOTCH-BRITE™ scouring pads or a STAINLESS scouring pad in combination with a powered



## HIGH LIMIT CONTROL

GLOBE Fryers are equipped with a secondary heat control that prevents the oil temperature from rising above 450°F. (Because of the accuracy tolerance of the sensor, the oil temperature may reach as high as 475°F.)

In the event the fryer shuts down due to this condition, the oil must be cooled to below 400°F before the pilot burner can be re-ignited. When the oil has cooled, use the "Lighting" procedure on page 12 to place the fryer back in operation. If the problem persists, contact your GLOBE Service Representative or the GLOBE Service Department.

## COOKING HINTS

### USER TIPS

- Smoking oil means that the temperature is too high, or that the oil has broken down.
- Gum in frypot denotes a need for thorough cleaning (see "Weekly Cleaning" on page 15)
- Use different oil for oily foods (mackerel, nutmeg, etc.) than for foods with water-soluble flavors (potatoes, onions, etc.).
- Taste cool oil for quality. Replace it regularly.
- Poor oil cannot produce good food.

## CLEANING

GLOBE equipment is constructed with the best quality materials and is designed to provide durable service when properly maintained. To expect the best performance, your equipment must be maintained in good condition and cleaned daily. Naturally, the frequency and extent of cleaning depends on the amount and degree of usage.

Following daily and more extensive periodic maintenance procedures will increase the life of your equipment. Climatic conditions (e.g., salt air) may result in the need for more thorough and more frequent cleaning in order to keep equipment performing at optimal levels.



### **WARNING: BURN HAZARD**

If necessary to move the fryer for cleaning, etc., drain oil first to avoid death or serious injury.



### **WARNING**

If disconnection of the restraint is necessary to move the appliance for cleaning, etc., reconnect it when the appliance is moved to its originally installed position.

SERVICE

### DAILY CLEANING

1. Turn thermostat knob to "OFF" position.
2. Place hot-oil in a safe container under the drain and drain the frypot completely.
3. Remove the basket support frame (if applicable) and flush out any sediment remaining in the frypot with a little hot oil.



## FILLING THE FRYPOT

1. Close drain valve completely before filling the frypot.
2. When the fryer is new, fill the frypot with water and clean thoroughly (see "Weekly Cleaning" on page 15) in order to remove protective coatings and any foreign matter.
3. The recommended solid shortening capacity for the frypot (35, 55 or 75lbs) is described on the serial plate (which is located inside the front door).
4. Remove the basket support frame when filling the frypot with solid shortening.
5. When solid shortening is used, be careful not to bend, break, or twist the thin capillary wires of the sensing elements located in the frypot.
6. Pack solid shortening into the zone below the tubes, all spaces between the tubes, and at least an inch above the top of the tubes before lighting the fryer. If any air spaces are left around the heat tube surfaces when the heat is turned on, the tube surfaces will become red hot, burn the solid shortening, weaken the frypot, and could result in a fire.

 **CAUTION**

*NEVER ATTEMPT TO MELT A SOLID BLOCK OF SHORTENING ON TOP OF THE HEAT TUBES.  
NEVER START THE BURNERS WHEN THE FRYPOT IS EMPTY.*

7. To prevent burning or scorching the solid shortening, keep the thermostat set at the lowest temperature until all the solid shortening between and above the tubes has been melted. Additional solid shortening can then be added until the desired frying depth has been reached.
8. Replace the basket support frame over the frypot heat tubes.

## SHUTDOWN PROCEDURE

**Standby:** Turn knob on the combination gas valve to the "PILOT" position. At this setting, only the pilot burner will remain ignited.

**Complete Shutdown:** Turn knob on the combination gas valve clockwise, press down on the knob and continue to turn to the "OFF" position.

## RELIGHTING

 **WARNING**

In the event of a main burner ignition failure, a five minute purge period must be observed prior to re-establishing the ignition source.

1. Shut off all gas.
2. Wait five minutes.
3. Follow the "Lighting" procedure described on page 12.

## AUTOMATIC PILOT VALVE

The Automatic Pilot Valve provides an automatic safety shutoff for the fryer when the pilot flame is extinguished. When the pilot flame is burning, the valve is held open electromagnetically by the electrical current from a thermopile in the pilot flame. When the pilot flame goes out, generation of current ceases and the valve closes automatically.



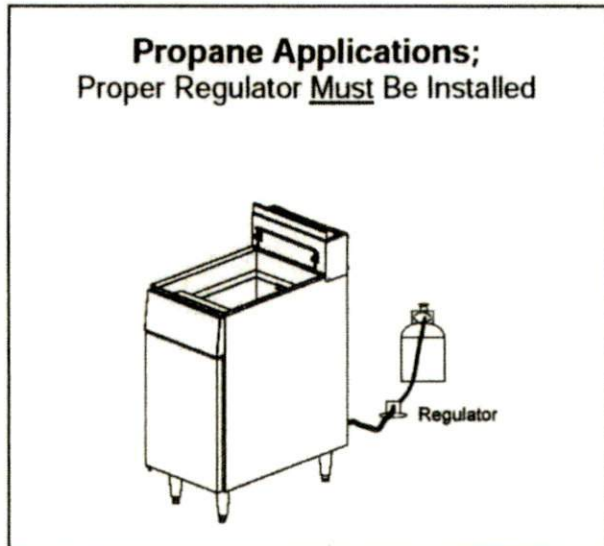

PHOTO 1

# OPERATION

## LIGHTING

**! CAUTION**

*IF YOU SMELL GAS DURING THE LIGHTING PROCEDURE, IMMEDIATELY SHUT OFF THE GAS SUPPLY UNTIL THE LEAK HAS BEEN CORRECTED.*

Open the burner compartment door and do the following:

1. Turn thermostat to "OFF"
2. Press down the knob of the combination gas valve, turn it counterclockwise to the "PILOT" position (shown), and continue to press the knob down.

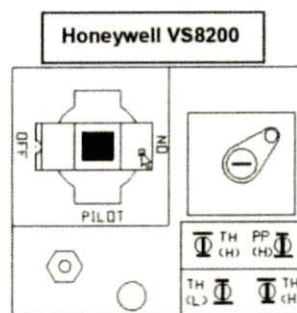
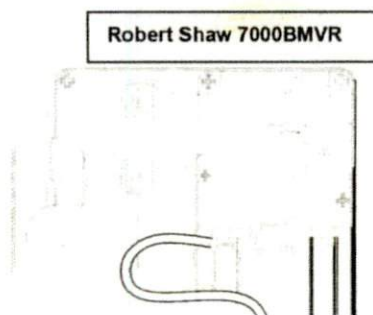

3. While pressing the knob down, use a lit match to ignite the pilot. Continue to press the knob down for about 30 seconds. If the pilot does not stay lit when the knob is released, repeat the lighting procedure and keep the knob down longer. Adjustment of pilot flame may be necessary.
4. When the pilot stays lit, turn the knob counterclockwise to the "ON" position. Do not press down on the knob in this step.
5. Do NOT turn the thermostat "ON" until the frypot is filled with oil or solid shortening.
6. Once the frypot is filled with shortening, set the thermostat to the desired temperature

SERVICE

**Step 5: Gas Connection**

A 3/4" male NPT line for the gas connection is located near the lower right rear corner of the fryer. The serial plate (located inside the front door of the fryer) indicates the type of gas the unit is equipped to burn (natural gas or propane). The fryer should be connected **ONLY** to the type of gas for which it is equipped.

A circuit diagram is located inside the front door of the fryer.

All GLOBE equipment is adjusted at the factory; however, pilot height should be checked at installation and adjusted, if necessary.

For orifice sizes and pressure regulator settings, see the chart on page 4. If the fryer is being installed at over 2,000 feet altitude and that information was not specified when ordered, contact the appropriate authorized GLOBE Service Representative or the GLOBE Service Department. Failure to install with proper orifice sizing will result in poor performance and may void the warranty.

If applicable, the vent line from the gas appliance pressure regulator shall be installed to the outdoors in accordance with local codes or, in the absence of local codes, with the *National Fuel Gas Code, ANSI Z223.1, Natural Gas Installation Code, CAN/CGA-B149.1*, or the *Propane Installation Code, CAN/CGA-B149.2*, as applicable.

An adequate gas supply is imperative. Undersized or low pressure lines will restrict the volume of gas necessary for satisfactory performance. A combination gas valve and pressure regulator, which is provided with each unit, is set to maintain a 4" W.C. manifold pressure for natural gas or 10.0" W.C. manifold pressure for propane gas. However, to maintain these conditions the pressure on the supply line, when all units are operating simultaneously, should not drop below 7" W.C. for natural gas or 11" W.C. for propane gas. Fluctuations of more than 25% on natural gas or 10% on propane gas will create problems and affect burner operating characteristics. A 1/8" tap to measure the manifold pressure is located on the combination gas valve, which is on the burner manifold located directly below the burners inside the cabinet.

Purge the supply line to clean out dust, dirt, or other foreign matter before connecting the line to the unit.

It is recommended that an individual manual shutoff valve be installed in the gas supply line to the unit.

Use pipe joint compound that is suitable for use with both natural and LP gas on all threaded connections.

 **CAUTION**

ALL PIPE JOINTS AND CONNECTIONS MUST BE TESTED THOROUGHLY FOR GAS LEAKS. USE ONLY SOAPY WATER FOR TESTING ON ALL GASES. NEVER USE AN OPEN FLAME TO CHECK FOR GAS LEAKS. ALL CONNECTIONS MUST BE CHECKED FOR LEAKS AFTER THE UNIT HAS BEEN PUT INTO OPERATION. **TEST PRESSURE SHOULD NOT EXCEED 14" W.C.**

 **CAUTION**

*THIS APPLIANCE AND ITS INDIVIDUAL COMBINATION GAS VALVE MUST BE DISCONNECTED FROM THE GAS SUPPLY PIPING SYSTEM DURING ANY PRESSURE TESTING OF THAT SYSTEM AT TEST PRESSURES IN EXCESS OF 14"WC (1/2 PSIG or 3.45 kPa).*

**If the incoming gas pressure is in excess of 14"WC (1/2PSI, 3.45 kPa), a proper step-down regulator will be required. See PHOTO 1 for LP application**

Connect the gas supply directly to the 3/4" male NPT connector located near the lower left rear corner of the fryer. When tightening the supply pipe, be sure to hold the mating connector extending from the unit securely with a wrench. This will prevent any damage or distortion to the internal piping and controls of the unit.

After connecting the gas supply, check again that the fryer is level. Use a long spirit level four ways; across the front and rear of the frypot, and along each edge.



**Step 4: Check Clearances and Ventilation**

Select a firm, level location for your fryer. Leave clearance, whenever possible, so that access from the rear is possible to permit cleaning. If the unit is to be set on non-combustible flooring, such as a concrete slab, 3 inches minimum toe room must be provided to prevent restriction of the air opening in the bottom of the unit.

**! WARNING**

There must be adequate clearance between fryer(s) and construction. Clearance must also be provided in front for servicing and for operation.

Minimum Clearances:

	From Combustible Construction
Sides	6 inches
Rear	6 inches

*ALL GLOBE FRYERS SHALL BE INSTALLED WITH AT LEAST A 16 INCH SPACE BETWEEN THE FRYER AND SURFACE FLAMES FROM ADJACENT EQUIPMENT. A FLAME GUARD IS ACCEPTABLE IF ALLOWED UNDER LOCAL CODE.*

No additional side and rear clearance is required for service as the fryer is serviceable from the front.

INSTALLATION

**! WARNING**

Improper ventilation can result in personal injury or death. Ventilation that fails to properly remove flue products can cause headaches, drowsiness, nausea, or could result in death.

Unit Must be installed under a ventilation hood

All units must be installed in such a manner that the flow of combustion and ventilation air is not obstructed. Provisions for adequate air supply must also be provided. Do NOT obstruct the bottom front of the unit, as combustion air enters through this area. Be sure to inspect and clean the ventilation system according to the ventilation equipment manufacturer's instructions.

Due to the variety of problems that can be caused by outside weather conditions, venting by canopies or wall fans is preferred over any type of direct venting. It is recommended that a canopy extend 6" past the appliance and the bottom edge be located 6"6" from the floor. Filters should be installed at an angle of 45° or more from the horizontal. This position prevents dripping of grease and facilitates collecting the run-off grease in a drip pan, unusually installed with a filter. A strong exhaust fan tends to create a vacuum in the room and may interfere with burner performance or may extinguish pilot flames. Fresh air openings approximately equal to the fan area will relieve such a vacuum. In case of unsatisfactory performance on any appliance, check the appliance with the exhaust fan in the "OFF" position. Do this only long enough to check equipment performance, then turn hood back on and let it run to remove any exhaust that may have accumulated during the test.

The exhaust fan should be installed at least 2 feet above the vent opening at the top of the fryer.

Make sure all ventilation meet local code requirement

This unit is not intended to be connected directly to an outside flue.



4. Secure it with four self-tapping screws two on the back and one on each side using a 5/16" socket

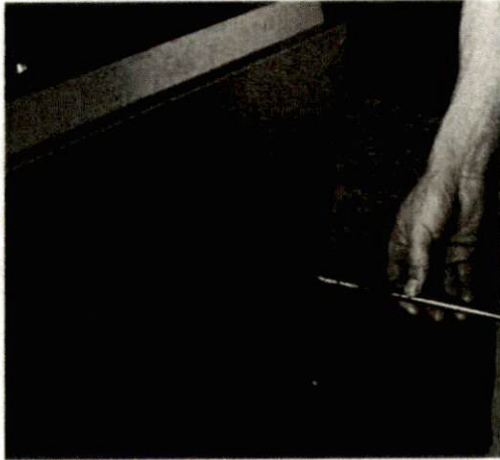

INSTALLATION



**Step 3: Flue Installation**

1. Unpack the flue box and flue wrap



INSTALLATION

2. Slide the flue box over the flue and secure it with the two self-tapping screws using a 5/16" socket

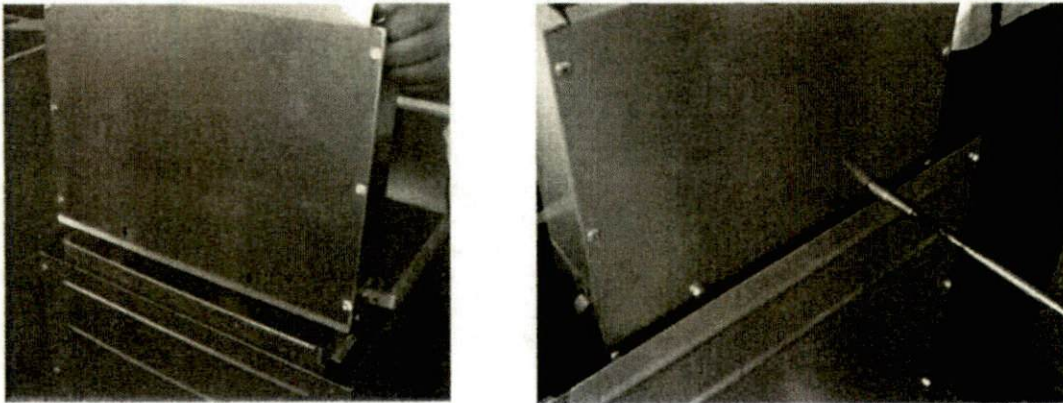

3. Slide the flue wrap over the flue

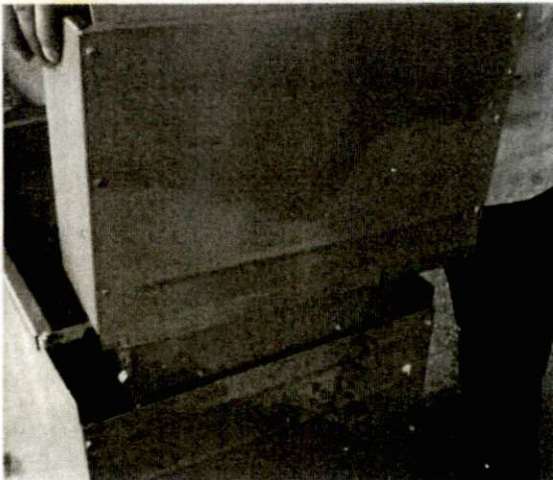



**Reach Ins**

**Service, Installation and Care Manual**

**Please read this manual completely before attempting to install or operate this equipment.  
Notify carrier of damage! Inspect all components immediately.**

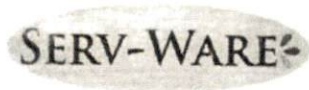
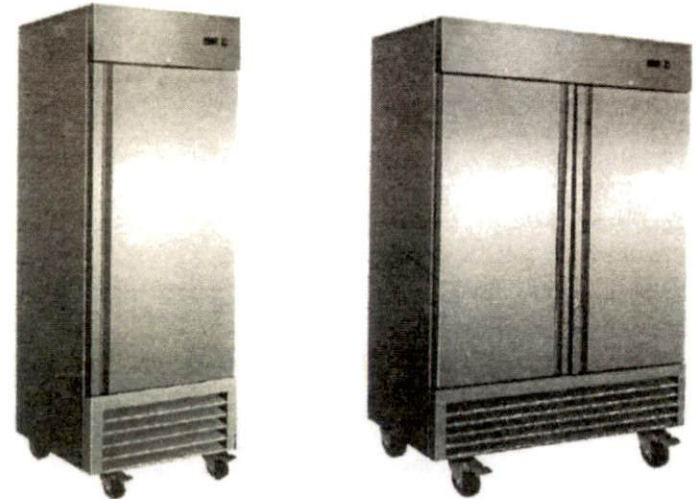

Serv-Ware Products 4684 Hwy 70 West  
Kinston, NC  
800-768-5953  
www.serv-ware.com

105010952

**IMPORTANT INFORMATION  
ABOUT YOUR SERV-WARE UNIT ENCLOSED.  
PLEASE READ BEFORE USE!  
SAVE THESE INSTRUCTIONS!**

PARTS & SERVICE MANUALS AVAILABLE AT  
[www.Serv-Ware.com](http://www.Serv-Ware.com)

## COMMERCIAL REFRIGERATOR SAFETY

**Your safety and the safety of others are very important.**

We have provided many important safety messages in this manual and on your appliance. Always read and obey all safety messages.

**Our product instructions will be uploaded on our company official website.**



This is the Safety Alert Symbol. This symbol alerts you to potential hazards that can kill or injure you and others. All safety messages will follow the Safety Alert Symbol and either the words "DANGER", "WARNING" or "CAUTION".



Danger means that failure to heed this safety statement may result in severe personal injury or death.



Warning means that failure to heed this safety statement may result in extensive product damage, serious personal injury, or death.



Caution means that failure to heed this safety statement may result in minor or moderate personal injury, or property or equipment damage.

All safety messages will alert you to what the potential hazard is, tell you how to reduce the chance of injury, and let you know what can happen if the instructions are not followed.

If the supply cord is damaged, it must be replaced by the manufacturer, its service agent or similarly qualified persons in order to avoid a hazard.

This appliance is not intended for use by persons (including children) with reduced physical, sensory or mental capabilities, or lack of experience and knowledge, unless they have been given supervision or instruction concerning use of the appliance by a person responsible for their safety.

Children should be supervised to ensure that they do not play with the appliance.

This appliance can be used by children aged from 8 years and above and persons with reduced physical sensory or mental capabilities or lack of experience and knowledge if they have been given supervision or instruction concerning use of the appliance in a safe way and understand the hazards involved. Children shall not play with the appliance. Cleaning and user maintenance shall not be made by children without supervision.

**Keep the appliance and its cord out of reach of children less than 8 years.**

**Do not store explosive substances such as aerosol cans with a flammable propellant in this appliance.**

The appliance use flammable insulation blowing gas C5H10, disposal of the appliance shall in accordance



**Reach Ins**

**Service, Installation and Care Manual**

**Please read this manual completely before attempting to install or operate this equipment.  
Notify carrier of damage! Inspect all components immediately.**

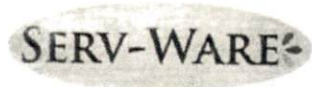
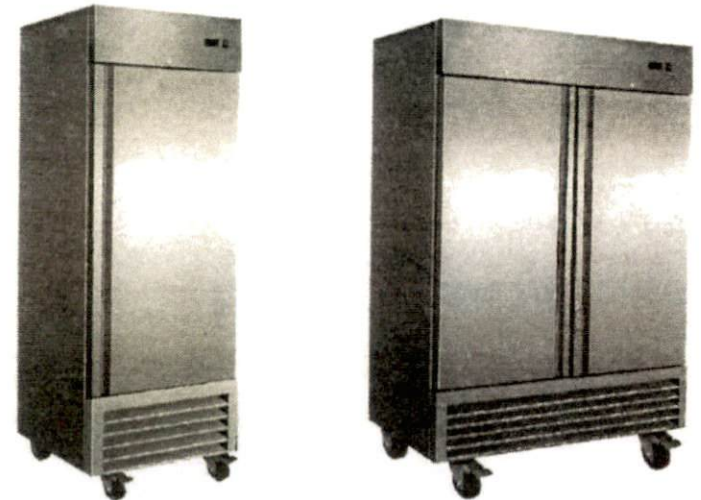

Serv-Ware Products 4684 Hwy 70 West  
Kinston, NC  
800-768-5953  
www.serv-ware.com

105010952

**IMPORTANT INFORMATION  
ABOUT YOUR SERV-WARE UNIT ENCLOSED.  
PLEASE READ BEFORE USE!  
SAVE THESE INSTRUCTIONS!**

PARTS & SERVICE MANUALS AVAILABLE AT  
www.Serv-Ware.com



## **COMMERCIAL REFRIGERATOR SAFETY**

**Your safety and the safety of others are very important.**

We have provided many important safety messages in this manual and on your appliance. Always read and obey all safety messages.

**Our product instructions will be uploaded on our company official website.**



This is the Safety Alert Symbol. This symbol alerts you to potential hazards that can kill or injure you and others. All safety messages will follow the Safety Alert Symbol and either the words "DANGER", "WARNING" or "CAUTION".



Danger means that failure to heed this safety statement may result in severe personal injury or death.



Warning means that failure to heed this safety statement may result in extensive product damage, serious personal injury, or death.

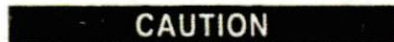

Caution means that failure to heed this safety statement may result in minor or moderate personal injury, or property or equipment damage.

All safety messages will alert you to what the potential hazard is, tell you how to reduce the chance of injury, and let you know what can happen if the instructions are not followed.

If the supply cord is damaged, it must be replaced by the manufacturer, its service agent or similarly qualified persons in order to avoid a hazard.

This appliance is not intended for use by persons (including children) with reduced physical, sensory or mental capabilities, or lack of experience and knowledge, unless they have been given supervision or instruction concerning use of the appliance by a person responsible for their safety.

Children should be supervised to ensure that they do not play with the appliance.

This appliance can be used by children aged from 8 years and above and persons with reduced physical sensory or mental capabilities or lack of experience and knowledge if they have been given supervision or instruction concerning use of the appliance in a safe way and understand the hazards involved. Children shall not play with the appliance. Cleaning and user maintenance shall not be made by children without supervision.

Keep the appliance and its cord out of reach of children less than 8 years.

Do not store explosive substances such as aerosol cans with a flammable propellant in this appliance.

The appliance use flammable insulation blowing gas C5H10, disposal of the appliance shall in accordance



**Step 3: Flue Installation**

1. Unpack the flue box and flue wrap



2. Slide the flue box over the flue and secure it with the two self-tapping screws using a 5/16" socket

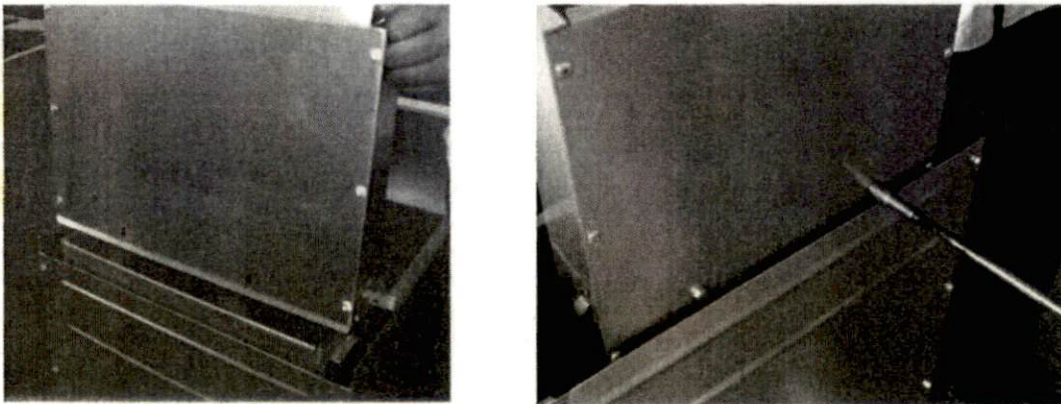

3. Slide the flue wrap over the flue

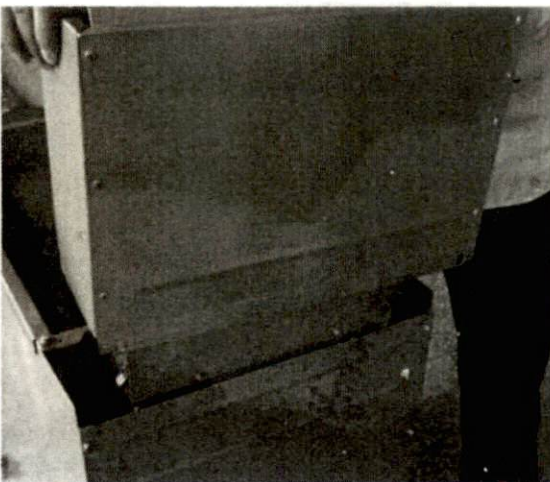

INSTALLATION



4. Secure it with four self-tapping screws two on the back and one on each side using a 5/16" socket



INSTALLATION

# Gas Countertop Griddles

## The Installation, Operation and Maintenance Guide

### Contents

1. Safety Protection.....	- 3 -
2. Brief Instruction.....	- 3 -
3. Manufacture' s Authority and Responsibility.....	- 3 -
4. Parameter Specifications.....	- 4 -
5. Transport and Storage.....	- 6 -
6. Installation and Debugging.....	- 6 -
7. Safety Notices and Precautions.....	- 8 -
8. Operating Instructions.....	- 9 -
9. Cleaning and Maintenance.....	- 11 -
10. Troubleshooting.....	- 13 -

Dear customers and users:

Thank you for purchasing our products. In order to be able to better use this product, please read these instructions carefully before any operation, and follow the guide, to avoid any unnecessary trouble during using.

Please keep this instruction manual in a safe place for convenient reference and operation.

This instruction manual is subject to any change without further notice, and the manufacturer reserves the right of final interpretation.

The appliance is designed for commercial purposes, not for household use.

A statement instructing the purchaser to post in a prominent location instructions to be followed in the event the user smells gas. This information shall be obtained by consulting the local gas supplier.

**FOR YOUR SAFETY**

Do not store or use gasoline or other flammable vapors or liquids in the vicinity of this or any other appliance.

**WARNING:** Improper installation, adjustment, alteration, service or maintenance can cause property damage, injury or death. Read the installation, operating and maintenance instructions thoroughly before installing or servicing this equipment.

**MAINTENANCE**

Cleaning solutions need to be alkaline based or non-chloride based. Any cleaner containing chlorides will damage the protective film of the stainless steel. Chlorides are commonly found in hard water, salts, and household and industrial cleaners. If cleaners containing chlorides are used, be sure to rinse and dry thoroughly.

Routine cleaning of stainless steel can be done with soap and water. Extreme stains or grease should be cleaned with a non-abrasive cleaner and plastic scrub pad. It is always good to rub with the grain of the steel. There are also stainless steel cleaners available which can restore and preserve the finish of the steel's protective layer.

Early signs of stainless steel breakdown can consist of small pits and cracks. If this has begun, clean thoroughly and start to apply stainless steel cleaners in attempt to restore the passivity of the steel.



CAUTION

**Never use an acid based cleaning solution! Many food products have an acidic content which can deteriorate the finish. Be sure to clean the stainless steel surfaces of ALL food products.**

**Gasket Maintenance**

Gaskets require regular cleaning to prevent mold and mildew build up and also to keep the elasticity of the gasket. Gasket cleaning can be done with the use of warm soapy water. Avoid full strength cleaning products on gaskets as this can cause them to become brittle and prevent proper seals. Do not use sharp tools or knives to scrape or clean the gasket which could possibly tear the gasket and rip the bellows.

Gaskets can easily be replaced and don't require the use of tools or authorized service technicians. The gaskets are "Dart" style and can be pulled out of the grove in the door and replaced by pressing the new one back into place.

**Doors/Hinges**

Over time and with heavy use, door hinges may become loose. If the door is beginning to sag, tighten the screws that mount the hinge brackets to the frame of the unit. If the doors are loose or sagging, this can cause the hinge to pull out of the frame which may damage both the doors and the door hinges.

**Drain Maintenance**

Each unit has a drain located inside the unit which removes the condensation from the evaporator coil and evaporates it into an external condensate evaporator pan. Each drain can become loose or disconnected from moving or bumping the drain. If you notice excessive water accumulation on the inside of the unit, be sure the drain tube is connected from the evaporator housing to the condensate evaporator drain pan. If water starts to collect underneath the unit, you may want to check the condensate evaporator drain tube to be sure it is still located inside the drain pan. The leveling of the unit is important as the units are designed to drain properly when on a level surface, if your floor is not level, this can also cause drain problems. Be sure all drain lines are free of obstructions because this may cause water to back up and overflow the drain pans.

**WIRING DIAGRAM**

MODEL: RR2-35-HC / RR2-HC

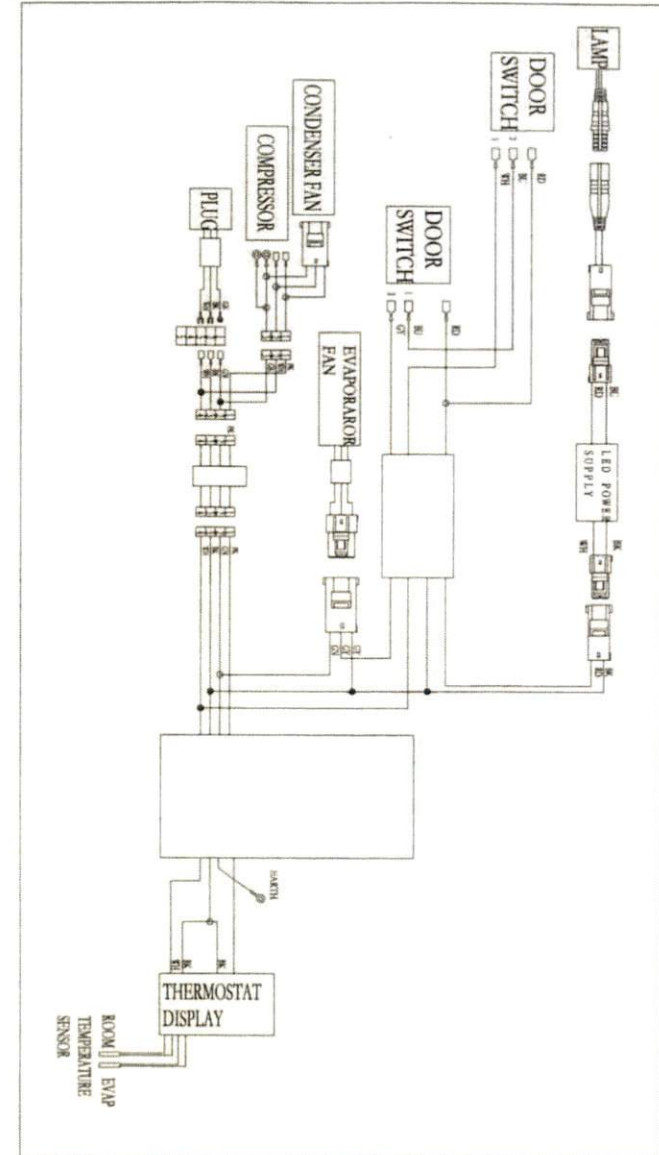

**WIRING DIAGRAM**

MODEL: RR2G-HC

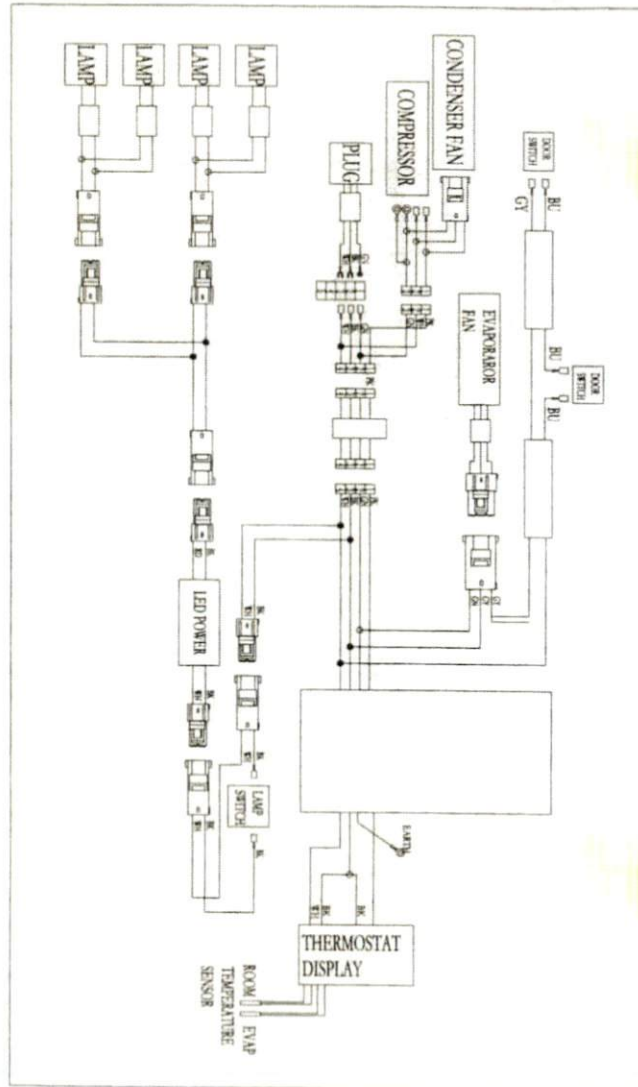
**MAINTENANCE**

The unit must be turned OFF and disconnected from the power source whenever performing service, maintenance functions or cleaning the refrigerated area.

**Refrigerators and Freezers**

The interior and exterior can be cleaned using soap and warm water. If this isn't sufficient, try ammonia or water or a nonabrasive liquid cleaner. When cleaning the exterior, always rub with the "grain" of the stainless steel to avoid marring the finish.

Do not use an abrasive cleaner because it will scratch the stainless steel and plastic and can damage the breaker strips and gaskets.

**Cleaning the Condenser Coil**

The condenser coil requires regular cleaning and it is recommended every 90 days. In some instances, you may find that there is a large amount of debris and dust or grease accumulated prior to the 90 day time frame. In these cases the condenser coil should be cleaned every 30 days.

If the build up on the coil consists of only light dust and debris, the condenser coil can be cleaned with a simple brush. Heavier dust build-up may require a vacuum or even compressed air to blow through the condenser coil.

If heavy grease is present, there are de-greasing agents available for refrigeration use and specifically for the condenser coils. The condenser coil may require cleaning with the de-greasing agent and then blown through with compressed air.

Failure to maintain a clean condenser coil can initially cause high temperatures and excessive run times. Continuous operation with dirty or clogged condenser coils can result in compressor failures. Neglecting the condenser coil cleaning procedures will void any warranties associated with the compressor or cost to replace the compressor.



**Never use a high pressure water wash for this cleaning procedure as water can damage the electrical components located near or at the condenser coil.**

In order to maintain proper refrigeration performance, the condenser fins must be cleaned of dust, dirt and grease regularly. It is recommended that this be done at least every three months. If conditions are such that the condenser is totally blocked in three months, the frequency of cleaning should be increased. Clean the condenser with a vacuum cleaner or stiff brush. If extremely dirty, a commercial-grade condenser cleaner may be required.

**Stainless Steel Care and Cleaning**

To prevent discoloration of rust on stainless steel several important steps need to be taken. First, we need to understand the properties of stainless steel. Stainless steel contains 70-80% iron which will rust. It also contains 12-30% chromium which forms an invisible passive film over the steel's surface which acts as a shield against corrosion. As long as the protective layer is intact, the metal is still stainless. If the film is broken or contaminated, outside elements can begin to breakdown the steel and begin to form rust or discoloration. Proper cleaning of stainless steel requires soft cloths or plastic scouring pads.



**NEVER USE STEEL PADS, WIRE BRUSHES OR SCRAPERS!**

DANGER

1.1 Function of LEDs

LED	MODE	SIGNIFICATO
❄️	On	Compressor enabled
	Flashing	Anti-short cycle delay enabled (AC parameter)
❄️	On	Defrost in progress
	Flashing	Dripping in progress
🌀	On	Fans output enabled
	Flashing	Fans delay after defrost
🌡️	On	Measurement unit
	Flashing	Programming mode
F	On	Measurement unit
	Flashing	Programming mode

2. MAIN FUNCTIONS

2.1 HOW TO SEE THE SETPOINT

1. Push and immediately release the **SET** key; the display will show the set point value.
2. Push and immediately release the **SET** key or wait for 5 seconds to display the sensor value again.



2.2 HOW TO CHANGE THE SETPOINT

1. Hold the **SET** key for more than 2 seconds to change the set point value.
2. The value of the set point will be displayed and the ❄️ LED starts blinking.
3. To change the set value, push the ▲ or ▼ key within 10s.
4. To set new point value, push the SET key again or wait 10s.

2.3 HOW TO START A MANUAL DEFFROST

Hold the ❄️ key for more than 2 seconds and a manual defrost will start



2.4 HOW TO LOCK THE KEYBOARD

1. Hold the ▲ and ▼ keys for more than 3s.
2. The "POF" message will be displayed and the keyboard will be locked. At this point, it will be possible only to see the set point or the MAX or Min temperature stored.
3. If a key is pressed more than 3s the "POF" message will be displayed.



2.5 HOW TO UNLOCK THE KEYBOARD

Hold the ▲ and ▼ keys together for more than 3s until the "POF" message is displayed.

3. ALARM SIGNALS

HOW TO SEE THE ALARM AND RESET THE RECORDED ALARM

1. Push the ▲ or ▼ key to display the alarm signals.
2. When the signal is displayed, hold the **SET** key until the "rst" message is displayed, and push the **SET** key again. The "rst" message starts blinking and the normal temperature will be displayed.

Message	Cause	Outputs
"P1"	Room probe failure	Compressor output according to par. "Con" and "COF"
"P2"	Evaporator probe failure	Defrost end is timed
"HA"	Maximum temperature alarm	Outputs unchanged.
"LA"	Minimum temperature alarm	Outputs unchanged.
"dA"	Door open	Compressor and fans restarts
"EA"	External alarm	Output unchanged.
"CA"	Serious external alarm (i1F=bAL)	All outputs OFF.
"CA"	Pressure switch alarm (i1F=PAL)	All outputs OFF

WIRING DIAGRAM

MODEL: RR3-HC

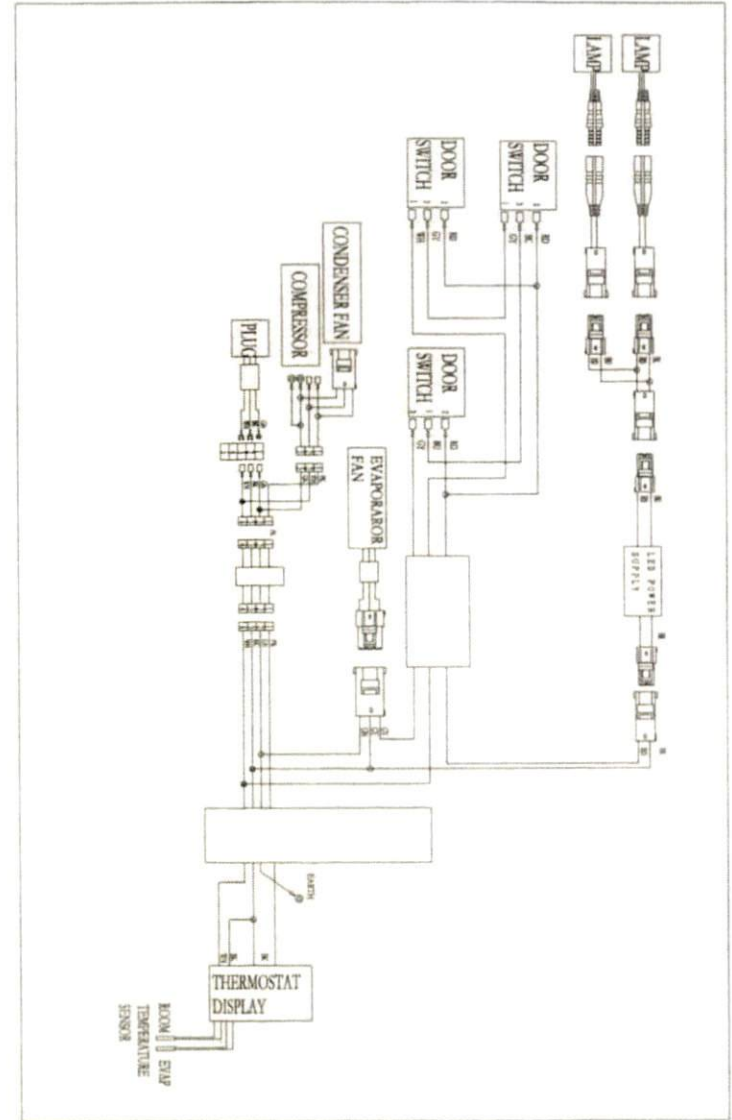



## WIRING DIAGRAM

MODEL: RF1-19-HC

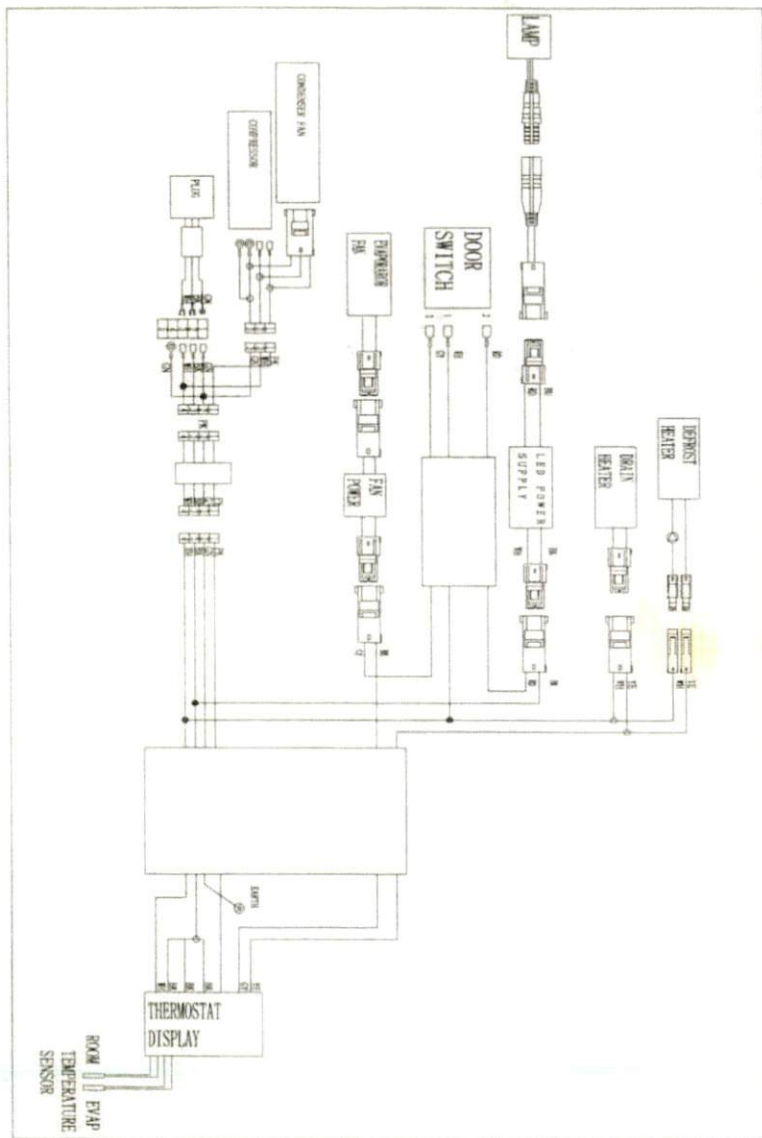

## OPERATION



Do not throw items into the storage area. Failure to heed these recommendations could result in damage to the interior of the cabinet.

### CAUTION

### Refrigerated cycle

**Refrigerators:** During the refrigeration cycle, the evaporator fans will run continuously even when one or more doors are open. The door switch will activate the lights when opened.

1. Every 6 hours, the unit will turn off and to allow the evaporator coil to defrost. The controller now displays defrost symbol. When the coil temperature reaches 41°F or after 20 minutes of defrost, the unit will turn on again.
2. Anti-condensation heaters on door frames work in conjunction with the compressor.
3. The factory setting for the temperature range is 34°F to 38° F.

**Freezers:** During the refrigeration cycle, the controller supplies power to the condensing unit and evaporator fan motors. The evaporator fans will run at any time when the evaporator coil temperature is below 54° F. They will also keep running when door is open but cycle off during a defrost period. The door switch will activate the lights when opened.

1. Every 6 hours, the unit will turn off and electric heater will turn on to defrost. The controller now displays the defrost symbol. When the coil temperature reaches 45°F or after 20 minutes of defrost, the unit will turn on again.
2. Anti-condensation heaters on door frames work in conjunction with the compressor.
3. The factory setting for temperature range is -7 to -3°F

### On/Off Switch:

An on/off switch is located on the front of the bottom panel. When the unit is on, the switch will glow green.

## SOLID-STATE THERMOSTAT DESCRIPTIONS

### 1. FRONT PANEL COMMANDS



**SET:** To display target set point; in programming mode it selects a parameter or confirm an operation.

- ❄️ (DEF) To start a manual defrost
- ▲ (UP) To view the last alarm occurrence; in programming mode it browses the parameter codes or increases the display value
- ▼ (DOWN) To view the last alarm occurrence; in programming mode it browses the parameter codes or decreases the display value

### KEY COMBINATION

- ▲ + ▼ To lock & unlock the keyboard
- SET + ▼ To enter in programming mode
- SET + ▲ To return to the room temperature display
- ⏻ To switch the instrument off.

## INSTALLATION

### Location

Units represented in this manual are intended for indoor use only. Be sure the location chosen has a floor strong enough to support the total weight of the cabinet and contents. A fully loaded unit can weigh as much as 1500 pounds. Reinforce the floor as necessary to provide for maximum loading. For the most efficient refrigeration, be sure to provide good air circulation inside and out.

### Inside cabinet:

Do not pack the units so full that air cannot circulate. The refrigerated air is discharged at the rear of the unit. It is important to allow for proper air flow from the rear to the front of the unit. Obstructions to this air flow can cause evaporator coil freeze ups and loss of temperature or overflow of water from the evaporator drain pan. The shelves have a rear turn up on them to prevent this. However, bags and other items can still be located to the far rear of the cabinet. Air is brought into the evaporator coil with fans mounted to the front of the coil.

### Outside cabinet:

Be sure that the unit has access to ample air. Avoid hot corners and locations near stoves and ovens. It is recommended that the unit be installed no closer than 2" from any wall with at least 12" of clear space above the unit.

### Leveling

A level cabinet looks better and will perform better because the doors will line up with the frames properly. Use a level to make sure the unit is level from front to back and side to side. Units supplied with legs will have adjustable bullet feet to make the necessary adjustments. If the unit is supplied with casters, no adjustments are available. Ensure the floor where the unit is to be located is level.

### Stabilizing

All models are supplied with casters for your convenience. It is very important, however, that the cabinet be installed in a stable condition with the front wheels locked while in use. Should it become necessary to lay the unit on its side or back for any reason, allow at least 24 hours before start-up to allow compressor oil to flow back into place. Failure to meet this requirement can cause compressor failure and unit damage.



NOTE

Unit repairs will not be subject to standard unit warranties if due to improper installation procedures.

### Electrical connection

Refer to the amperage data on page 3, the serial tag, your local code or the National Electrical Code to be sure the unit is connected to the proper power source.



DANGER

The unit must be turned OFF and disconnected from the power source whenever performing service, maintenance functions or cleaning the refrigerated area.

## WIRING DIAGRAM

MODEL: RF1-HC

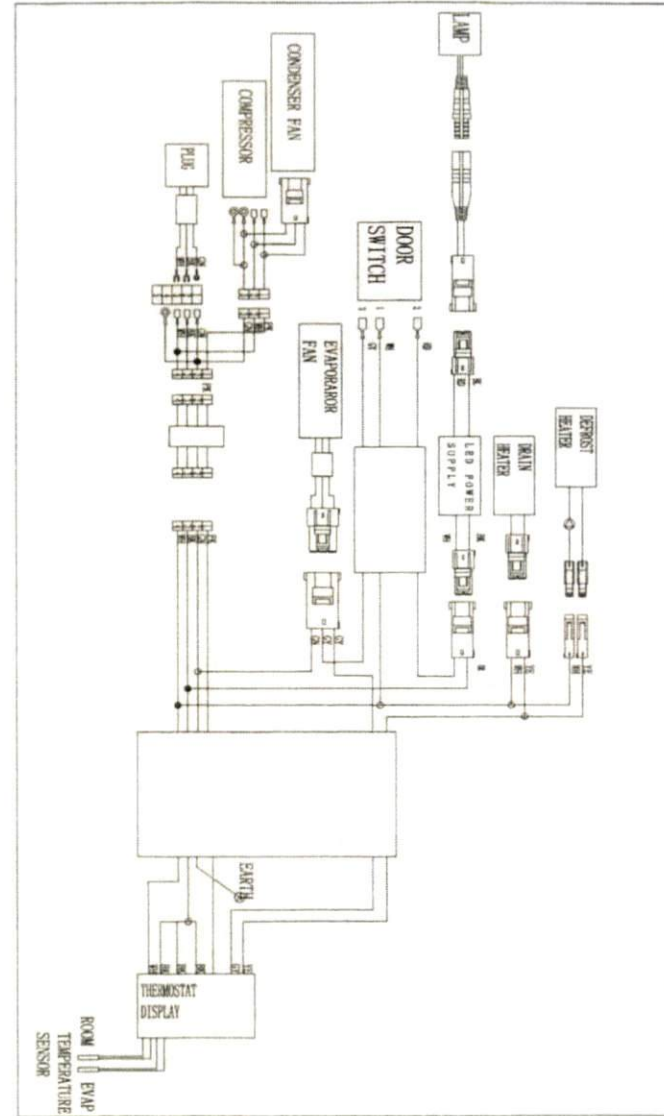

**WIRING DIAGRAM**

MODEL: RF2-35-HC / RF2-HC

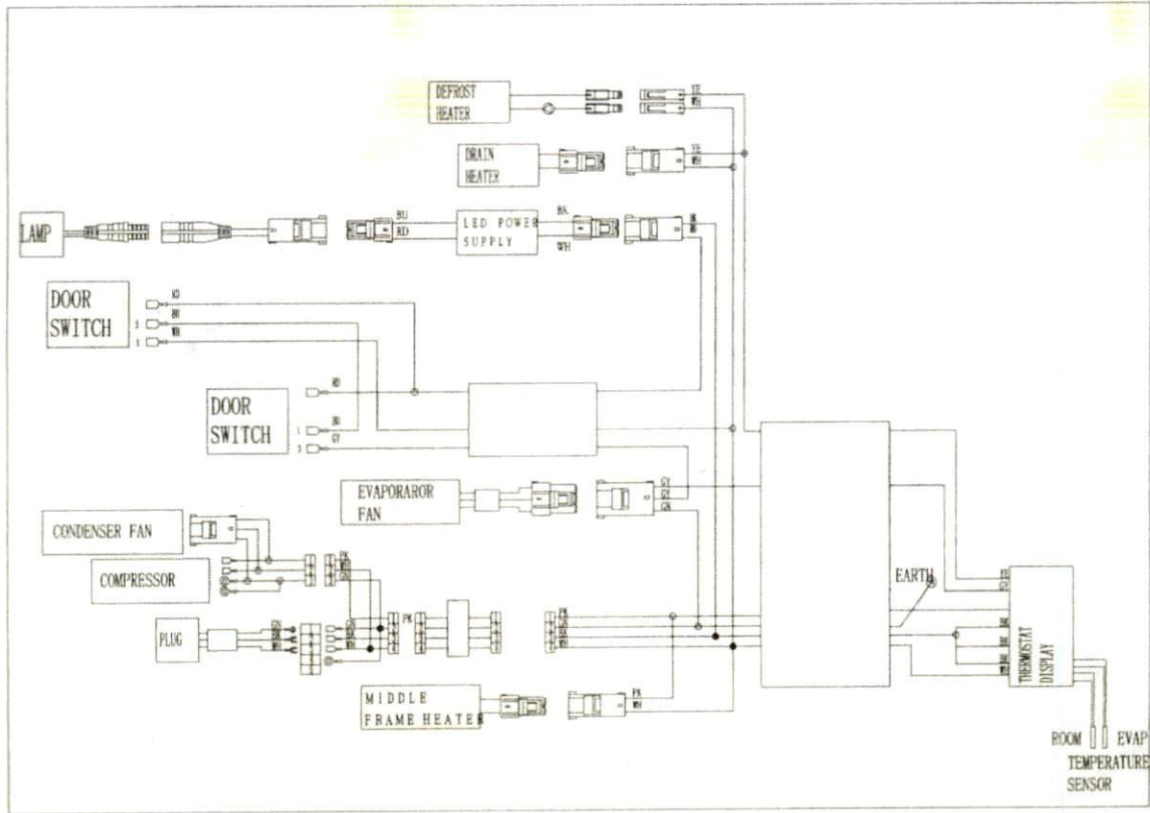

**SPECIFICATION**

**SOLID DOOR REFRIGERATORS**

MODEL#	V/Hz/Ph	AMPS	STORAGE CAPACIT	HP	SHELF CAPACITY Sq-ft	BTU	CHARGE OZ	SHIP WEIGHT LBS	NEMA PLUG
RR1-19-HC	115/60/1	3	13	1/5	13.0	1670	2.82	220	5-15P
RR1-HC	115/60/1	3	23	1/5	14.0	1670	3.0	350	5-15P
RR2-35-HC	115/60/1	4.5	35	1/4	26.1	2380	3.7	313	5-15P
RR2-HC	115/60/1	4.5	49	1/4	28.1	2380	3.7	518	5-15P
RR3-HC	115/60/1	7.5	72	1/2	42.1	3200	5.29	669	5-15P

**GLASS DOOR REFRIGERATORS**

MODEL#	V/Hz/Ph	AMPS	STORAGE CAPACIT	HP	SHELF CAPACITY Sq-ft	BTU	CHARGE OZ	SHIP WEIGHT LBS	NEMA PLUG
RR1G-HC	115/60/1	3	23	1/5	14.0	1670	3.0	350	5-15P
RR2G-HC	115/60/1	4.5	49	1/4	28.1	1670	3.7	518	5-15P

**SOLID DOOR FREEZERS**

MODEL#	V/Hz/Ph	AMPS	STORAGE CAPACIT	HP	SHELF CAPACITY Sq-ft	BTU	CHARGE OZ	SHIP WEIGHT LBS	NEMA PLUG
RF1-19-HC	115/60/1	5	13	1/2	13.0	2000	3.53	225	5-15P
RF1-HC	115/60/1	8	23	1/2	14.0	2000	3.88	364	5-15P
RF2-35-HC	115/60/1	9	35	1	26.1	3650	5.29	320	5-15P
RF2-HC	115/60/1	9	49	1	28.1	3650	5.29	568	5-15P
RF3DV-HC	115/208-230/60/1	9	72	1-1/4	42.1	4500	5.29	776	L14-20P



1.1 Function of LEDs

LED	MODE	SIGNIFICATO
❄️	On	Compressor enabled
	Flashing	Anti-short cycle delay enabled (AC parameter)
❄️	On	Defrost in progress
	Flashing	Dripping in progress
🌀	On	Fans output enabled
	Flashing	Fans delay after defrost
°C	On	Measurement unit
	Flashing	Programming mode
°F	On	Measurement unit
	Flashing	Programming mode

2. MAIN FUNCTIONS

2.1 HOW TO SEE THE SETPOINT

1. Push and immediately release the **SET** key; the display will show the set point value.
2. Push and immediately release the **SET** key or wait for 5 seconds to display the sensor value again.



2.2 HOW TO CHANGE THE SETPOINT

1. Hold the **SET** key for more than 2 seconds to change the set point value.
2. The value of the set point will be displayed and the ❄️ LED starts blinking.
3. To change the set value, push the ▲ or ▼ key within 10s.
4. To set new point value, push the SET key again or wait 10s.

2.3 HOW TO START A MANUAL DEFFROST

Hold the ❄️ key for more than 2 seconds and a manual defrost will start



2.4 HOW TO LOCK THE KEYBOARD

1. Hold the ▲ and ▼ keys for more than 3s.
2. The "POF" message will be displayed and the keyboard will be locked. At this point, it will be possible only to see the set point or the MAX or Min temperature stored.
3. If a key is pressed more than 3s the "POF" message will be displayed.

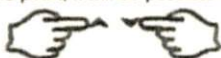

2.5 HOW TO UNLOCK THE KEYBOARD

Hold the ▲ and ▼ keys together for more than 3s until the "POF" message is displayed.

3. ALARM SIGNALS

HOW TO SEE THE ALARM AND RESET THE RECORDED ALARM

1. Push the ▲ or ▼ key to display the alarm signals.
2. When the signal is displayed, hold the **SET** key until the "rst" message is displayed, and push the **SET** key again. The "rst" message starts blinking and the normal temperature will be displayed.

Message	Cause	Outputs
"P1"	Room probe failure	Compressor output according to par. "Con" and "COF"
"P2"	Evaporator probe failure	Defrost end is timed
"HA"	Maximum temperature alarm	Outputs unchanged.
"LA"	Minimum temperature alarm	Outputs unchanged.
"dA"	Door open	Compressor and fans restarts
"EA"	External alarm	Output unchanged.
"CA"	Serious external alarm (if F=bAL)	All outputs OFF.
"CA"	Pressure switch alarm (if F=pAL)	All outputs OFF.

WIRING DIAGRAM

MODEL: RR3-HC

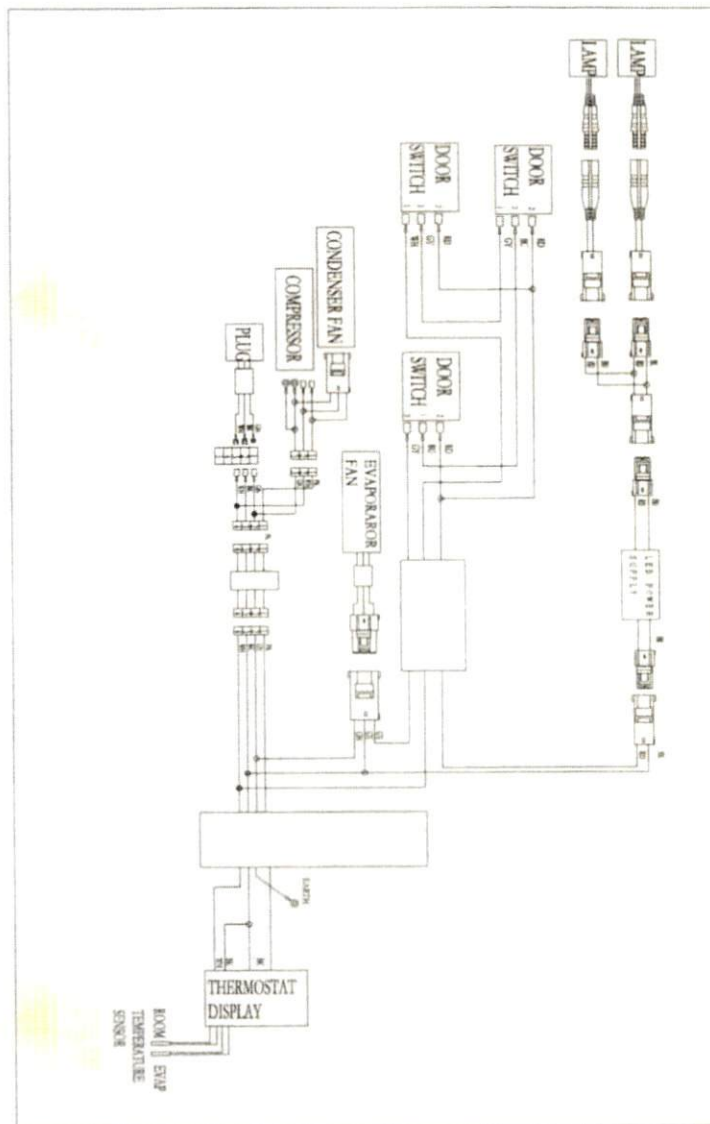

## WIRING DIAGRAM

MODEL: RF1-19-HC

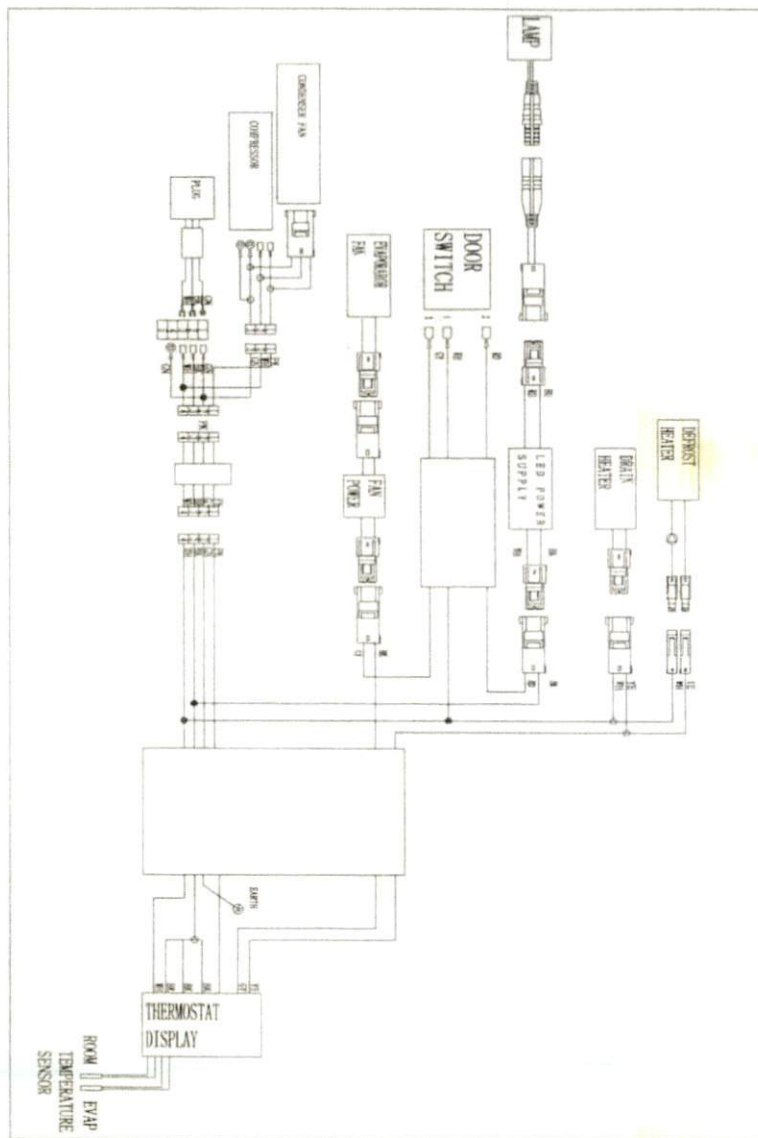

## OPERATION



Do not throw items into the storage area. Failure to heed these recommendations could result in damage to the interior of the cabinet.

### CAUTION

### Refrigerated cycle

**Refrigerators:** During the refrigeration cycle, the evaporator fans will run continuously even when one or more doors are open. The door switch will activate the lights when opened.

1. Every 6 hours, the unit will turn off and to allow the evaporator coil to defrost. The controller now displays defrost symbol. When the coil temperature reaches 41°F or after 20 minutes of defrost, the unit will turn on again.
2. Anti-condensation heaters on door frames work in conjunction with the compressor.
3. The factory setting for the temperature range is 34°F to 38°F.

**Freezers:** During the refrigeration cycle, the controller supplies power to the condensing unit and evaporator fan motors. The evaporator fans will run at any time when the evaporator coil temperature is below 54°F. They will also keep running when door is open but cycle off during a defrost period. The door switch will activate the lights when opened.

1. Every 6 hours, the unit will turn off and electric heater will turn on to defrost. The controller now displays the defrost symbol. When the coil temperature reaches 45°F or after 20 minutes of defrost, the unit will turn on again.
2. Anti-condensation heaters on door frames work in conjunction with the compressor.
3. The factory setting for temperature range is -7 to -3°F.

### On/Off Switch:

An on/off switch is located on the front of the bottom panel. When the unit is on, the switch will glow green.

## SOLID-STATE THERMOSTAT DESCRIPTIONS

### 1. FRONT PANEL COMMANDS

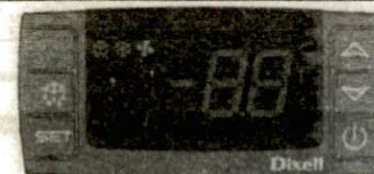

**SET:** To display target set point; in programming mode it selects a parameter or confirm an operation.

**⚙️ (DEF)** To start a manual defrost

**▲ (UP)** To view the last alarm occurrence; in programming mode it browses the parameter codes or increases the display value

**▼ (DOWN)** To view the last alarm occurrence; in programming mode it browses the parameter codes or decreases the display value

### KEY COMBINATION

**▲ + ▼** To lock & unlock the keyboard

**SET + ▼** To enter in programming mode

**SET + ▲** To return to the room temperature display

**⏻** To switch the instrument off.

**MAINTENANCE**

Cleaning solutions need to be alkaline based or non-chloride based. Any cleaner containing chlorides will damage the protective film of the stainless steel. Chlorides are commonly found in hard water, salts, and household and industrial cleaners. If cleaners containing chlorides are used, be sure to rinse and dry thoroughly.

Routine cleaning of stainless steel can be done with soap and water. Extreme stains or grease should be cleaned with a non-abrasive cleaner and plastic scrub pad. It is always good to rub with the grain of the steel. There are also stainless steel cleaners available which can restore and preserve the finish of the steel's protective layer.

Early signs of stainless steel breakdown can consist of small pits and cracks. If this has begun, clean thoroughly and start to apply stainless steel cleaners in attempt to restore the passivity of the steel.



**Never use an acid based cleaning solution! Many food products have an acidic content which can deteriorate the finish. Be sure to clean the stainless steel surfaces of ALL food products.**

**Gasket Maintenance**

Gaskets require regular cleaning to prevent mold and mildew build up and also to keep the elasticity of the gasket. Gasket cleaning can be done with the use of warm soapy water. Avoid full strength cleaning products on gaskets as this can cause them to become brittle and prevent proper seals. Do not use sharp tools or knives to scrape or clean the gasket which could possibly tear the gasket and rip the bellows.

Gaskets can easily be replaced and don't require the use of tools or authorized service technicians. The gaskets are "Dart" style and can be pulled out of the groove in the door and replaced by pressing the new one back into place.

**Doors/Hinges**

Over time and with heavy use, door hinges may become loose. If the door is beginning to sag, tighten the screws that mount the hinge brackets to the frame of the unit. If the doors are loose or sagging, this can cause the hinge to pull out of the frame which may damage both the doors and the door hinges.

**Drain Maintenance**

Each unit has a drain located inside the unit which removes the condensation from the evaporator coil and evaporates it into an external condensate evaporator pan. Each drain can become loose or disconnected from moving or bumping the drain. If you notice excessive water accumulation on the inside of the unit, be sure the drain tube is connected from the evaporator housing to the condensate evaporator drain pan. If water starts to collect underneath the unit, you may want to check the condensate evaporator drain tube to be sure it is still located inside the drain pan. The leveling of the unit is important as the units are designed to drain properly when on a level surface, if your floor is not level, this can also cause drain problems. Be sure all drain lines are free of obstructions because this may cause water to back up and overflow the drain pans.

**WIRING DIAGRAM**

MODEL: RR2-35-HC / RR2-HC

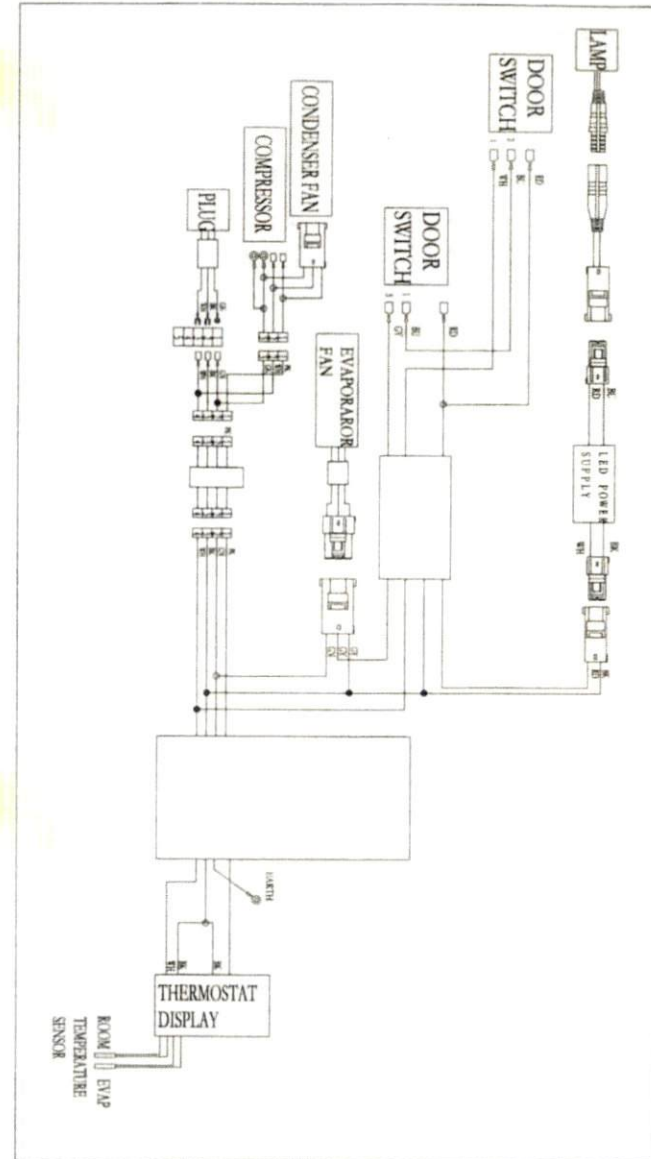

**WIRING DIAGRAM**

MODEL: RR2G-HC

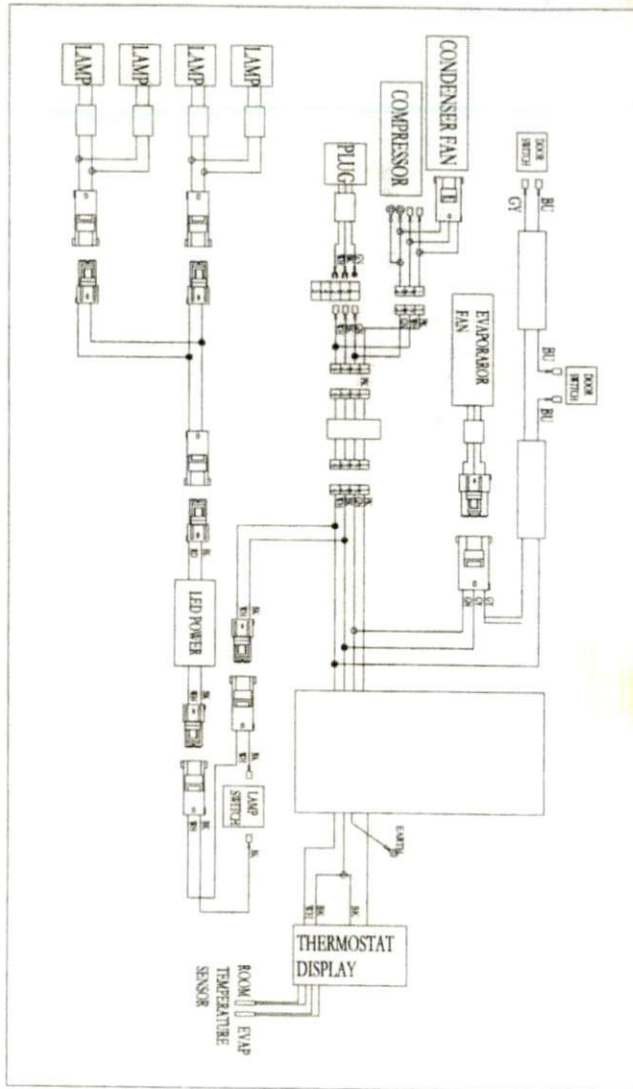

**MAINTENANCE**



The unit must be turned OFF and disconnected from the power source whenever performing service, maintenance functions or cleaning the refrigerated area.

**Refrigerators and Freezers**

The interior and exterior can be cleaned using soap and warm water. If this isn't sufficient, try ammonia or water or a nonabrasive liquid cleaner. When cleaning the exterior, always rub with the "grain" of the stainless steel to avoid marring the finish.

Do not use an abrasive cleaner because it will scratch the stainless steel and plastic and can damage the breaker strips and gaskets.

**Cleaning the Condenser Coil**

The condenser coil requires regular cleaning and it is recommended every 90 days. In some instances, you may find that there is a large amount of debris and dust or grease accumulated prior to the 90 day time frame. In these cases the condenser coil should be cleaned every 30 days.

If the build up on the coil consists of only light dust and debris, the condenser coil can be cleaned with a simple brush. Heavier dust build-up may require a vacuum or even compressed air to blow through the condenser coil.

If heavy grease is present, there are de-greasing agents available for refrigeration use and specifically for the condenser coils. The condenser coil may require cleaning with the de-greasing agent and then blown through with compressed air.

Failure to maintain a clean condenser coil can initially cause high temperatures and excessive run times. Continuous operation with dirty or clogged condenser coils can result in compressor failures. Neglecting the condenser coil cleaning procedures will void any warranties associated with the compressor or cost to replace the compressor.



Never use a high pressure water wash for this cleaning procedure as water can damage the electrical components located near or at the condenser coil.

In order to maintain proper refrigeration performance, the condenser fins must be cleaned of dust, dirt and grease regularly. It is recommended that this be done at least every three months. If conditions are such that the condenser is totally blocked in three months, the frequency of cleaning should be increased. Clean the condenser with a vacuum cleaner or stiff brush. If extremely dirty, a commercial-grade condenser cleaner may be required.

**Stainless Steel Care and Cleaning**

To prevent discoloration of rust on stainless steel several important steps need to be taken. First, we need to understand the properties of stainless steel. Stainless steel contains 70-80% iron which will rust. It also contains 12-30% chromium which forms an invisible passive film over the steel's surface which acts as a shield against corrosion. As long as the protective layer is intact, the metal is still stainless. If the film is broken or contaminated, outside elements can begin to breakdown the steel and begin to form rust or discoloration. Proper cleaning of stainless steel requires soft cloths or plastic scouring pads,



NEVER USE STEEL PADS, WIRE BRUSHES OR SCRAPERS!

DANGER

**WIRING DIAGRAM**

MODEL: RR1G-HC

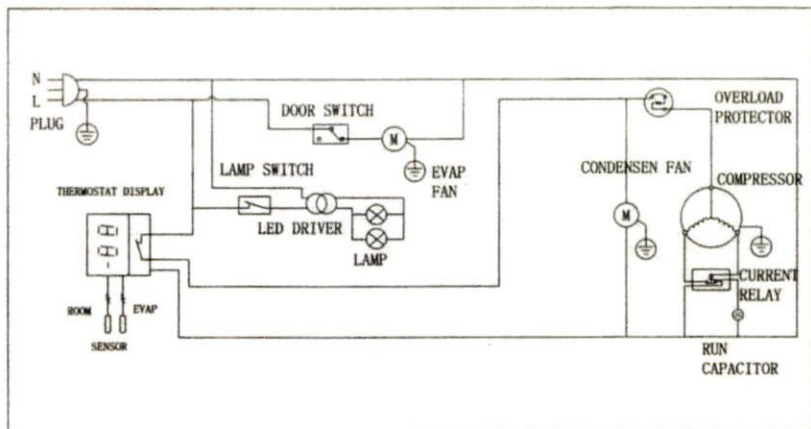

MODEL: RR2-35-HC / RR2-HC

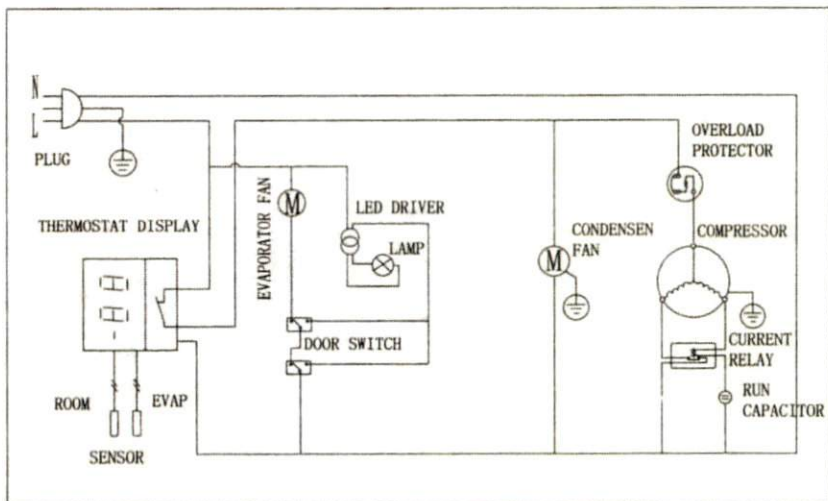

**WIRING DIAGRAM**

MODEL: RR1-HC

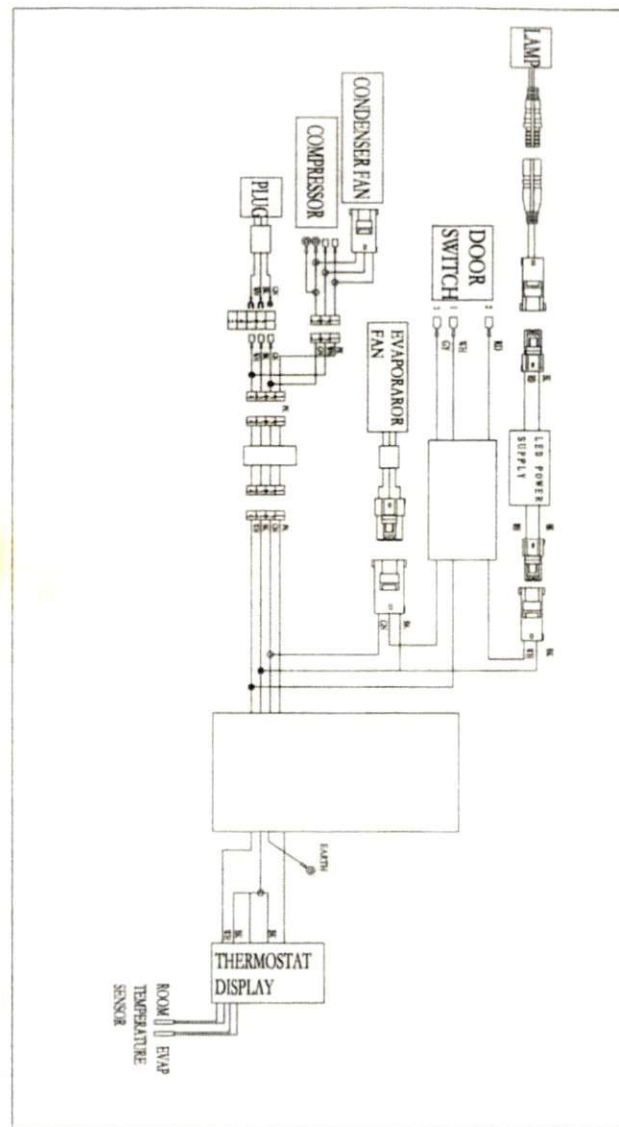



**WIRING DIAGRAM**

MODEL: RR1G-HC

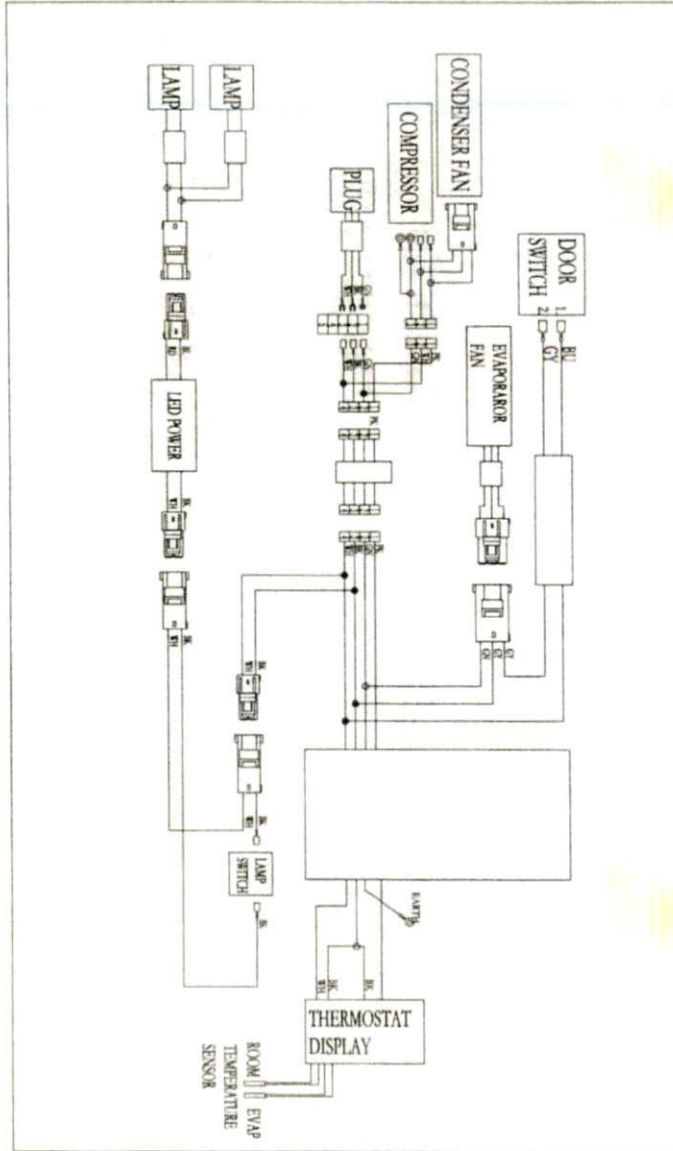

**WIRING DIAGRAM**

MODEL: RR1-19-HC

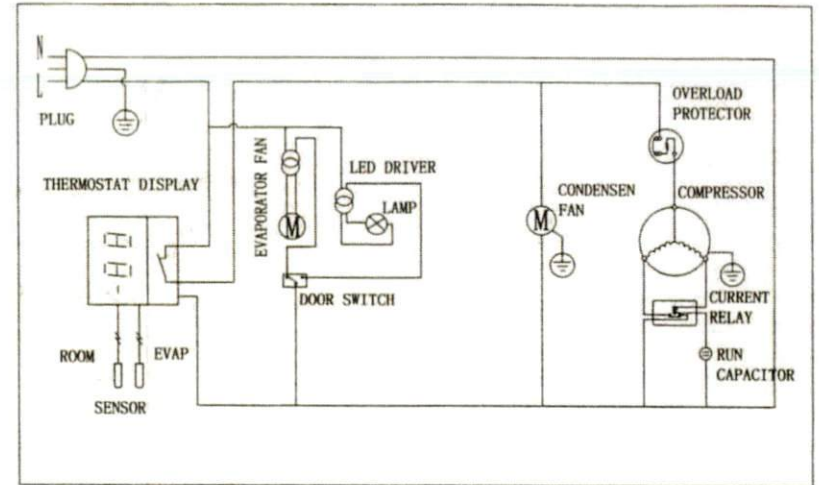

MODEL: RR1-HC

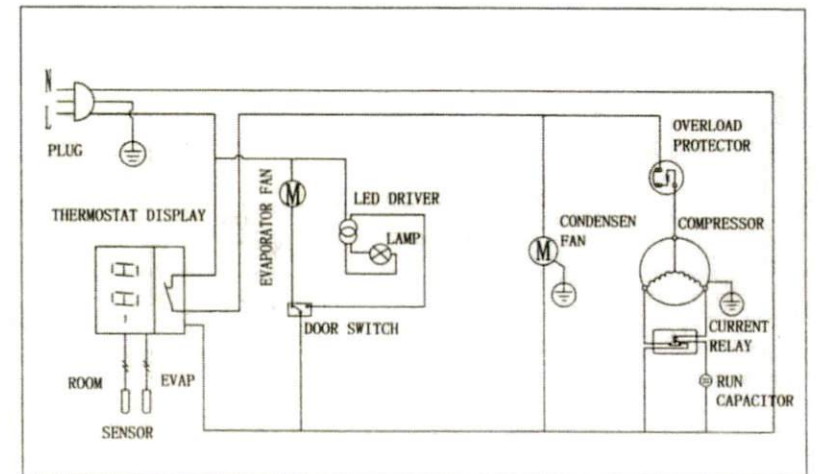

**WIRING DIAGRAM**

**WIRING DIAGRAM**

MODEL: RF1-19-HC

MODEL: RF2-HC

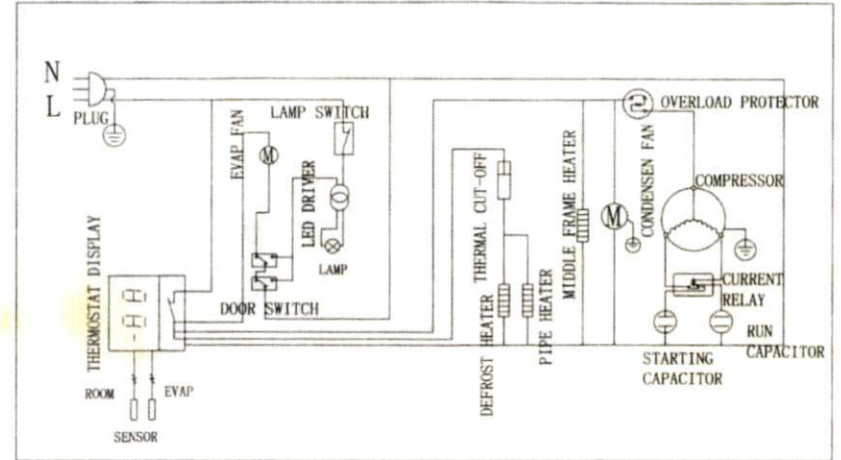
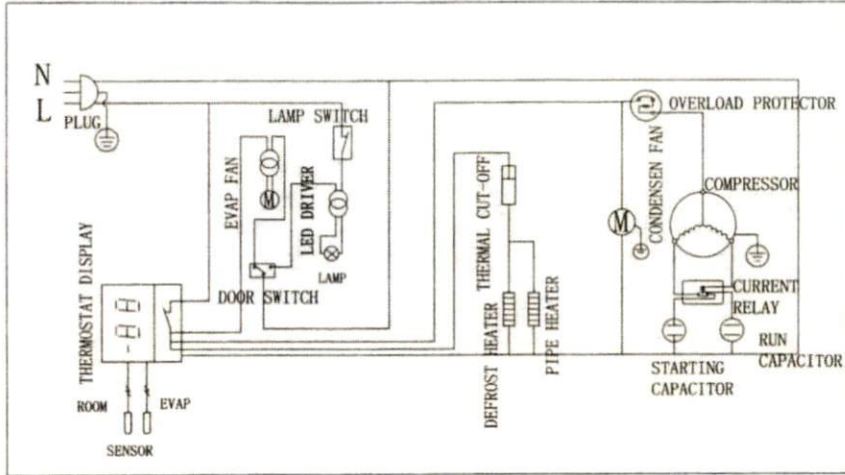

MODEL: RF1-HC

MODEL: RF3DV-HC

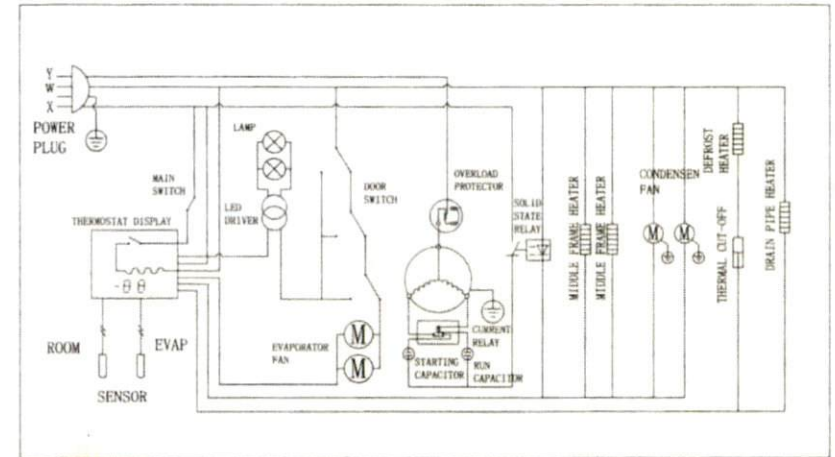
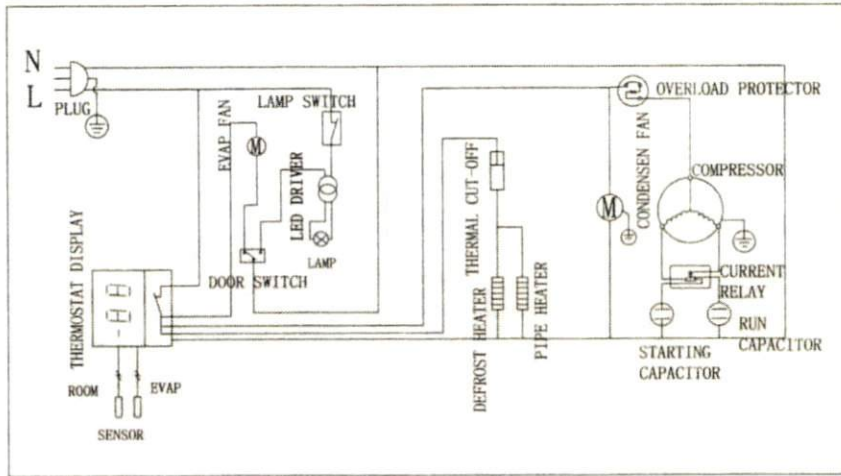

**WIRING DIAGRAM**

MODEL: RR1-19-HC

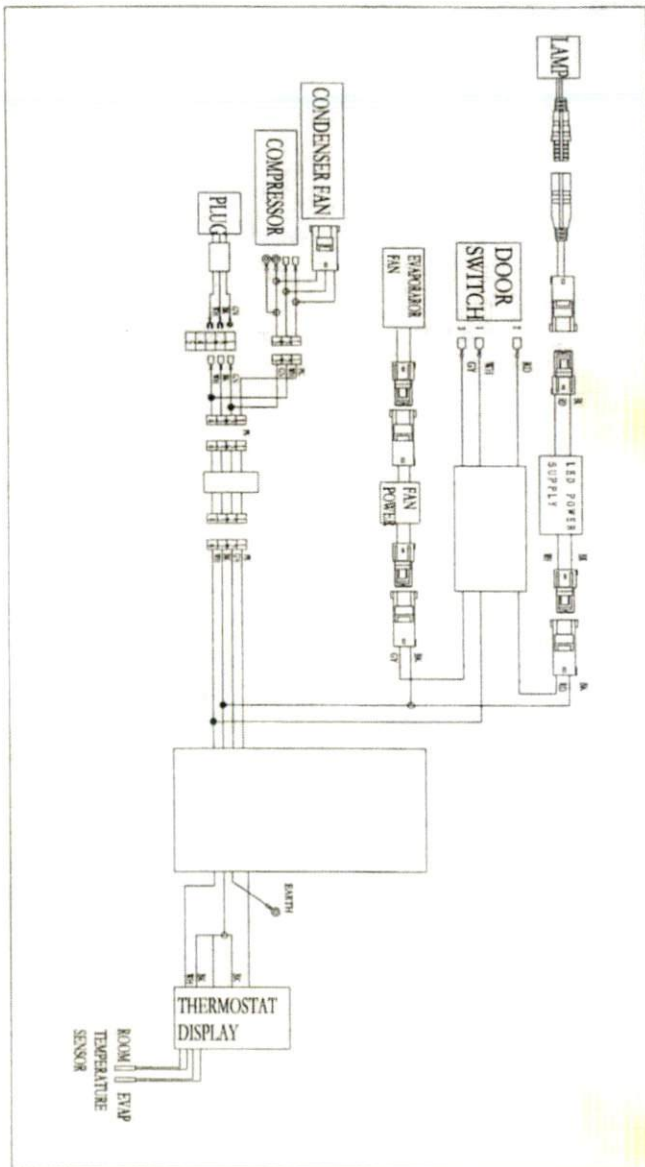

**WIRING DIAGRAM**

MODEL: RR2G-HC

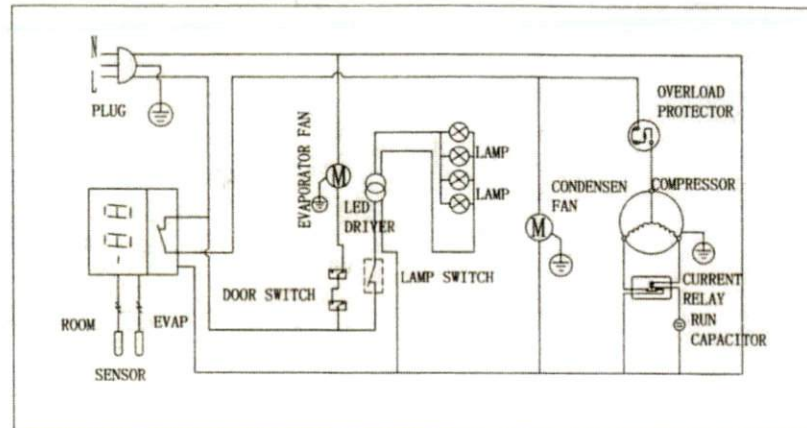

MODEL: RR3-HC

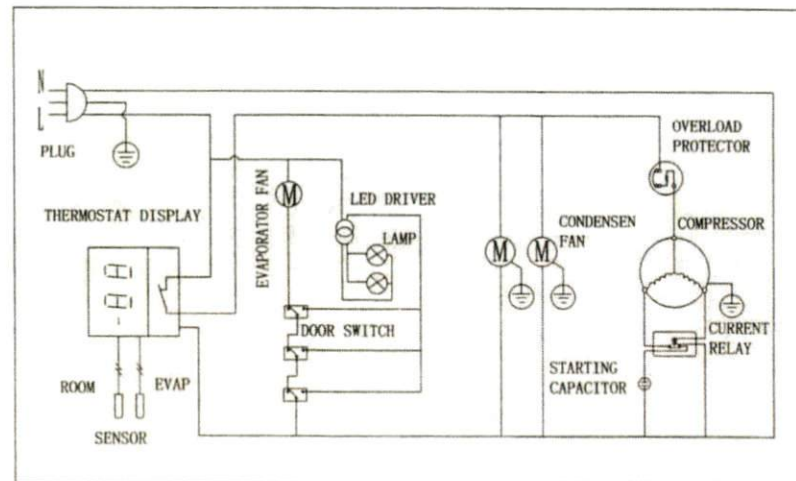

## 5. Transport and Storage

In the process of transportation, handle carefully and keep upright to prevent damage of the product packing. Wrapped equipment should not be in open air for a long time, and shall be placed in a well-ventilated and non-corrosive gases warehouse. When equipment needs temporary storage, waterproof measures should be taken.

## 6. Installation and Debugging

⚠ Any erroneous installation, adjustment, refit, overhaul or maintenance may cause property damage or personal injury. The work shall be performed by authorized and licensed technicians, otherwise the manufacturer has the right not to provide warranty service;

⚠ Only be installed in accordance with the local code. If no similar standard, you should conform to the National Fuel Gas Code, ANSI Z223.1/NFPA 54, the National Gas Installation Code, CSA-B149.1, or the L.P. Gas Installation Code, CSA-B149.2 as applicable;

⚠ The appliance individual shutoff valve must be disconnected from the gas supply piping system during any pressure testing of that system at test pressures in excess of 1/2psi (3.45kPa).

### 6.1. Unpacking and Installation

⚠ Please dispose of all packaging materials and residues after unpacking;

⚠ Check the equipment. If it is damaged, please keep wrappers and receipts which must be signed by the carrier representative (Driver), and contact the carriers to pursue a claim within 15 days after receiving;

⚠ Be sure to install supporting legs before using, and do not tear up any label or logo before normal using;

⚠ Please read these instructions carefully before installation and operation. Please contact your local agent if you have any questions;

⚠ The equipment shall be installed on a level, solid, non-skid and incombustible surface, and placed in a well-lighted work area with waterproof, and stay away from children and customers;

⚠ The installation position is a well-ventilated place in accordance with the local regulations;

The char broiler must be installed under the matched cooking fume exhauster according to the local regulations;

⚠ **Important:** Installation and ventilation laws, and codes are very different, you should state and comply with all codes of the National Fire Protection Association Inc when it comes to requirements for installation of equipment;

⚠ Screw 4 adjustable stainless steel legs in the tapping hole at four corners of the char broiler bottom, ensure sufficient space for ventilation;

⚠ Adjustable stainless steel legs to make the equipment level, and get the

### ATTG-48

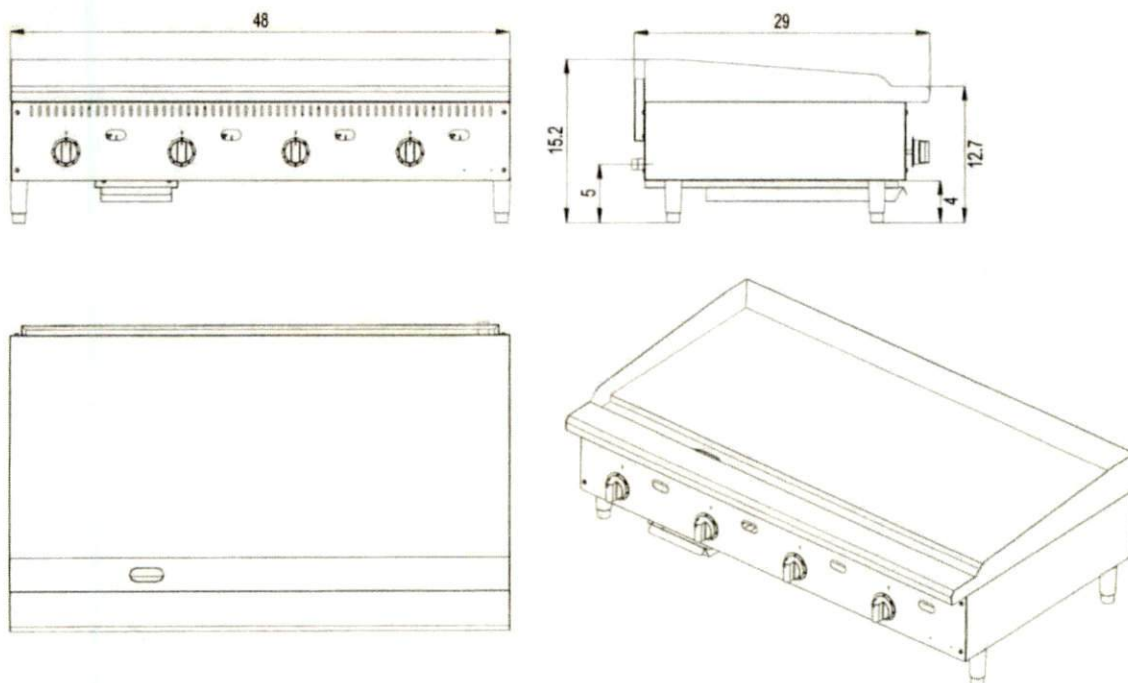

#### 4.2. Information of Gas Supply and Burner

The minimum supplied gas pressure regulator is factory set at 4" Natural Gas W.C, and 10" L.P. Gas W.C. The external thread of product' s intake-tube is 3/4 inches.

<Table 1>

Model	#of burners and control method	Gas Species	Intake-tube pressure (in. W. C. )	Per BTU B. T. U. /h	Total BTU B. T. U. /h	Nozzle No.
ATTG-24	2 pieces Independent control	Natural Gas	4	25,000	50,000	#42
		L.P. Gas	10	25,000	50,000	#53
ATTG-36	3 pieces Independent control	Natural Gas	4	25,000	75,000	#42
		L.P. Gas	10	25,000	75,000	#53
ATTG-48	4 pieces Independent control	Natural Gas	4	25,000	100,000	#42
		L.P. Gas	10	25,000	100,000	#53

## 7. Safety Notices and Precautions

⚠ Warning! For your safety, do not place petrol and other flammables nearby. Please keep clean and free of flammables surroundings. (Read ANSI Z83.14B, 1991 for reference)

⚠ Warning! Any erroneous installation, adjustment and refit may cause property damage or personal injury and maintenance failure. Read the instructions carefully before installation and using.

⚠ Warning! Operation instruction must be placed in a conspicuous location. When customers smell gas in the process of using, you should take safety precautions immediately. Immediately turn off the main gas valve, extinguish all heat and flames, and call 911. Safety information can be obtained from your local gas suppliers.

When using this equipment, safety precautions should always be followed, including the following:

⚠ The griddles burners, grates and outside surfaces may become hot after using, so you must be careful to touch;

⚠ During operation, do not directly touch burners and plates;

⚠ Turn off the equipment as not in using, cleaning, servicing or adjusting any parts or attachments.

⚠ If the equipment has any problems of equipment damage, gas piping leaks, igniter or valves damage, or lose product accessories, do not operate by yourself and call for the service immediately;

⚠ The attachments not recommended or sold by the manufacturer may cause fire, personal injury, even death;

⚠ Do not use out of doors;

⚠ The equipment is used for grill, not available for any other using;

⚠ The equipment does not contain any user-serviceable parts. Dealers or technicians will repair it. Do not take apart any spare parts without authorization;

⚠ Never change any other parts without authorization to this equipment, otherwise, may cause hazards, and the manufacturer has the right not to provide warranty service;

⚠ Steel cutting producers used to manufacture with sharp edges. The manufacturer has dealt with these sharp edges during production, however, we insist the operator take care when in contact with this piece of equipment;

⚠ Always keep hands, hair and clothing away from heating source.

⚠ Wait the unit cools down before you cleaning. Because the unit is too hot to handle after using.

same level with other series of the equipment; Please lift the equipment rather than drag if you need to move it;

△ Supplied gas pressure regulator is factory set at 4" Natural Gas W.C, and 10" L.P. Gas W.C;

△ The equipment can only be placed on the incombustible counter top, and keep a distance at least 6 inches(152mm) to equipment' s both sides and back, and keep a distance at least 4 inches(102mm) to the bottom;

△ Do not put anything around the equipment, and on the counter top and bottom, in order to avoid influencing combustion and air circulation;

△ Leave enough distance in front of the equipment to take apart the control panel. All major parts, in addition to the burner remove from the front intake-tube;

△ It may be necessary to adjust the balance of air input by authorized and licensed technicians;

△ Thread glue must be resistant to the action of liquefied petroleum gases.

△ **Warning!** Use soap water or testing instrument to test whether piping joint leaks or not before using, and forbid using an open flame to test!

△ After installing completely, you should check gas supply pressure. Use a pressure gauge which is equipped with liquid (such as U-type pressure gauge, the minimum value is 0.1mbar) or a digital pressure gauge to test. Steps are

△ as following:

- Remove top panel, and needle type pressure joint screw arbor (Fig.1), then slip rubber tube of pressure gauge over needle type pressure joint;

- Start the equipment in accordance with the instructions, measuring gas supply pressure (dynamic pressure) in the work state;

- Access to the equipment if measured data within the limits of Table 1, otherwise, you will need to adjust gas pressure regulating valve or contact gas supplier to bargain;

- Unplug pressure gauge after you accomplish pressure testing, then install needle type pressure joint screw arbor. **Important: make sure screw up the needle valve to prevent gas escape!**

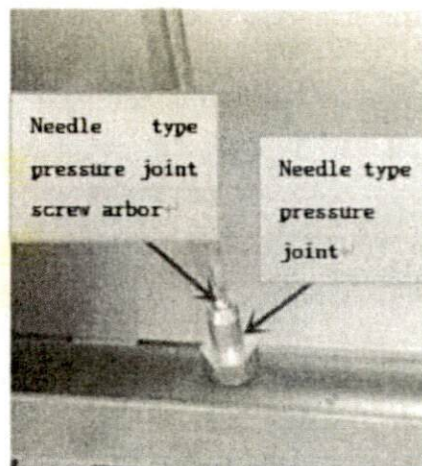

Fig.1

## 6.2、Debugging

It' s very important to debug the new stove. Through the comprehensive system test of equipment, we can ensure function and safety performance of products. Discovering any potential problems before use (such as equipment' s placement, ventilation, operation, etc), can avoid costly losses.

Notice:

1. Pressure maintaining valve connects with air intake must be installed by authorized and licensed technicians to ensure interface tightness.
2. Screw the hex nut (Fig. 8) before connect air intake, ensure gas mark (Fig. 9) on the plastic core match with connected gas source, if not, then pull out the plastic core and change another head, insert it again. The same as exchanging gas source.
3. When exchange gas source, use the main fire orifice (Fig. 10) in the accessories. Follow rules of 8.5.

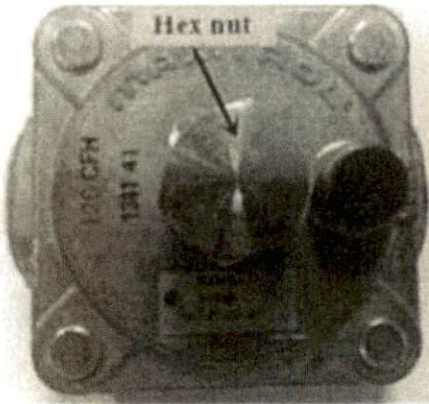

Fig. 8

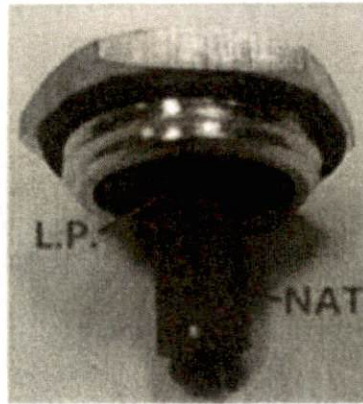

Fig. 9

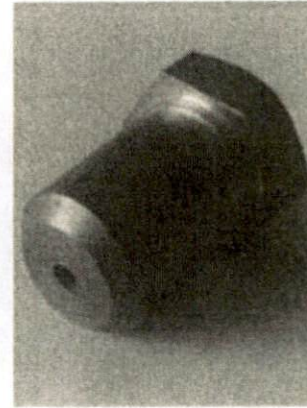

Fig. 10



Conforms to ANSI STD Z83.11-2016  
Certified to CSA STD 1.8-2016  
Conforms to NSF/ANSI STD.4

Our products have the advantages of good durability and low maintenance charge. But to update some components and necessary maintenance, can prolong life length of the products. Contact the dealer for assistance.



## 10. Troubleshooting

<Table 3>

Problems	Possible causes	Problem solving
Not lighting	1. Insufficient gas pressure in pipe	1. Contact the local gas supply dept.
	2. Nozzle occlusion	2. Dredge nozzle
Ignite the pilot light but not the main fire	1. Insufficient gas pressure in pipe	1. Contact the local gas supply dept.
	2. The main fire nozzle occlusion	2. Dredge nozzle
	3. Gas control valves have problems	3. Change gas control valves
	4. The pilot light and the main fire's distance is too far	4. Adjust the distance of them
	5. Flame is too low	5. Adjust the height of the pilot light
Close gas and heard a sound of fire	1. Insufficient gas pressure in pipe	1. Contact the local gas supply dept.
	2. Not match nozzle aperture with gas resources	2. Adjust nozzle diameter
	3. Flow of connection pipe is not enough	3. Increase pipe's allowable flow
	4. Damper opening degree is too large	4. Adjust damper
Yellow flame and black smoke	1. Use the gas of bottom	1. Change gas
	2. Not match nozzle diameter with gas resources	2. Adjust nozzle diameter
	3. Not enough air to ignite	3. Increase damper opening degree
	4. In the peak of using gas, sources of gas float heavy	4. Turn down valves flow. Turn it up after the peak

The problems mentioned above are only for reference. If any fault occurs, please stop using, and contact technicians to check and repair. Safety first, turn off the power and gas supply before maintenance.

**CONTENTS**

RECEIVING & INSPECTING EQUIPMENT.....4  
 SPECIFICATIONS.....5  
 INSTALLATION.....6  
 OPERATION.....7  
 MAINTENANCE.....9  
 WIRING DIAGRAM.....11

All rights reserved. Reproduction without written permission is prohibited.

**SERIAL NUMBER INFORMATION**

The serial number of all self-contained refrigerators and freezers is located inside the unit on the left hand side near the top on the wall.

Always have the serial number of your unit available when calling for parts or service.

This manual covers standard units only. If you have a custom unit, consult the customer service department at the number listed on the last page.

**RECEIVING AND INSPECTING THE EQUIPMENT**

Even though most equipment is shipped crated, care should be taken during unloading so the equipment is not damaged while being moved into the building.

1. Visually inspect the exterior of the package and skid or container. Any damage should be noted and reported to the delivering carrier immediately.
2. If damaged, open and inspect the contents with the carrier.
3. In the event that the exterior is not damaged, yet upon opening, there is concealed damage to the equipment, notify the carrier. Notification should be made verbally as well as in written form.
4. Request an inspection by the shipping company of the damaged equipment. This should be done within 10 days from receipt of the equipment.
5. Be certain to check the compressor compartment housing and visually inspect the refrigeration package. Be sure lines are secure and base is still intact.
6. Freight carriers can supply the necessary damage forms upon request.
7. Retain all crating material until an inspection has been made or waived.

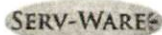

**WIRING DIAGRAM**

MODEL: RF3DV-HC

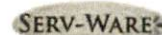
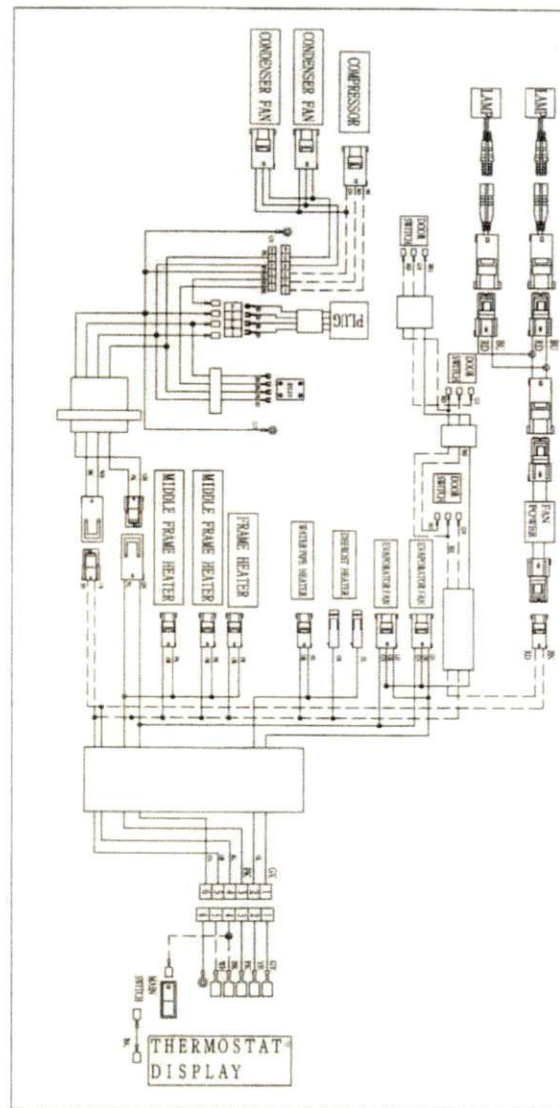

## Service and Installation Manual

with the regulations of local authorities.

The key for appliance electric box should be safe kept by qualified persons in order to avoid a hazard



Warning: Risk of fire / flammable materials

**WARNING:** Keep ventilation openings, in the appliance enclosure or in the built-in structure, clear of obstruction.

**WARNING:** Do not use mechanical devices or other means to accelerate the defrosting process, other than those recommended by the manufacturer.

**WARNING:** Do not damage the refrigerant circuit.

**WARNING:** Do not use electrical appliances inside the food storage compartments of the appliance, unless they are of the type recommended by the manufacturer.

Handling, moving, and use of the refrigerator or freezer to avoid either damaging the refrigerant tubing, or increasing the risk of a leak

L'opération, le mouvement et l'utilisation du réfrigérant ou le congélateur doivent éviter les dommages du tuyau réfrigérant ou le risque de la fuite.

Caution – Risk of Fire or Explosion due to Flammable Refrigerant Used. Follow Handling

Instructions Carefully in Compliance with U.S. Government Regulations.

Component parts shall be replaced with like components and that servicing shall be done by factory authorized service personnel, so as to minimize the risk of possible ignition due to incorrect parts or improper service.

Les pièces de rechange doivent être remplacées par les composants relatifs et les opérations doivent être faites par les professionnels afin de minimaliser le risque d'allumage à cause des parts incorrects ou de opérations impropres.

CAUTION – Risk Of Fire Or Explosion Due To Puncture Of Refrigerant Tubing; Follow Handling Instruction Carefully. Flammable Refrigerant Used

DANGER: Risk of child entrapment. Before you throw away your old refrigerator or freezer:

Take off the doors

Leave the shelves in place so that children may not easily climb inside.

## INSTALLATION

### Location

Units represented in this manual are intended for indoor use only. Be sure the location chosen has a floor strong enough to support the total weight of the cabinet and contents. A fully loaded unit can weigh as much as 1500 pounds. Reinforce the floor as necessary to provide for maximum loading. For the most efficient refrigeration, be sure to provide good air circulation inside and out.

### Inside cabinet:

Do not pack the units so full that air cannot circulate. The refrigerated air is discharged at the rear of the unit. It is important to allow for proper air flow from the rear to the front of the unit. Obstructions to this air flow can cause evaporator coil freeze ups and loss of temperature or overflow of water from the evaporator drain pan. The shelves have a rear turn up on them to prevent this. However, bags and other items can still be located to the far rear of the cabinet. Air is brought into the evaporator coil with fans mounted to the front of the coil.

### Outside cabinet:

Be sure that the unit has access to ample air. Avoid hot corners and locations near stoves and ovens. It is recommended that the unit be installed no closer than 2" from any wall with at least 12" of clear space above the unit.

### Leveling

A level cabinet looks better and will perform better because the doors will line up with the frames properly. Use a level to make sure the unit is level from front to back and side to side. Units supplied with legs will have adjustable bullet feet to make the necessary adjustments. If the unit is supplied with casters, no adjustments are available. Ensure the floor where the unit is to be located is level.

### Stabilizing

All models are supplied with casters for your convenience. It is very important, however, that the cabinet be installed in a stable condition with the front wheels locked while in use. Should it become necessary to lay the unit on its side or back for any reason, allow at least 24 hours before start-up to allow compressor oil to flow back into place. Failure to meet this requirement can cause compressor failure and unit damage.



**NOTE** Unit repairs will not be subject to standard unit warranties if due to improper installation procedures.

### Electrical connection

Refer to the amperage data on page 3, the serial tag, your local code or the National Electrical Code to be sure the unit is connected to the proper power source.



**DANGER** The unit must be turned OFF and disconnected from the power source whenever performing service, maintenance functions or cleaning the refrigerated area.

## WIRING DIAGRAM

MODEL: RF1-HC

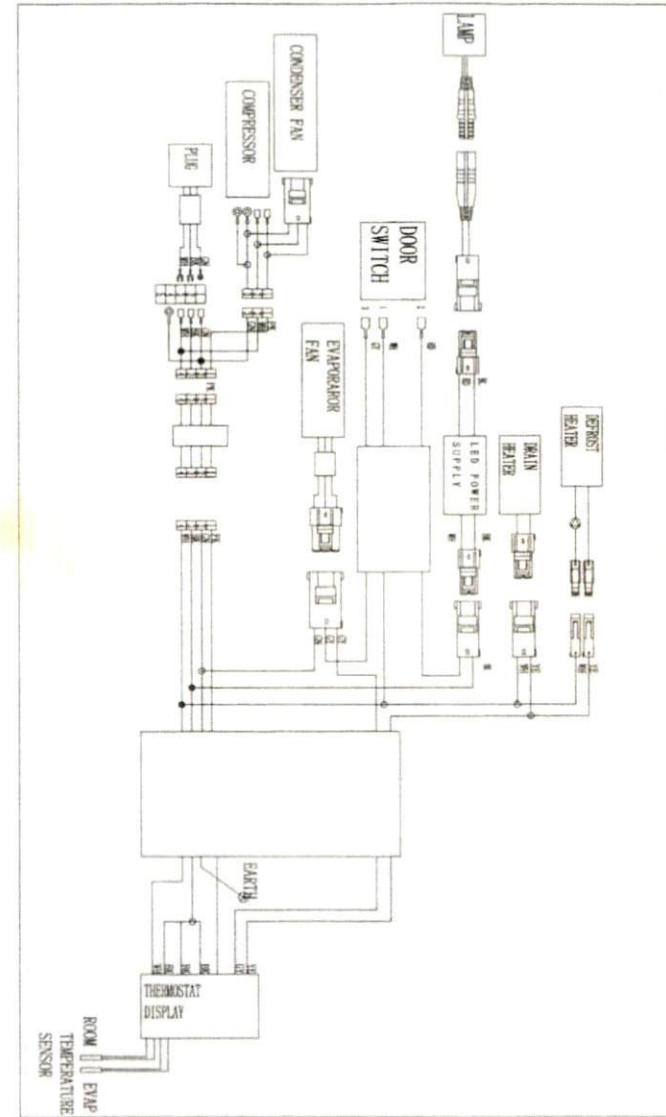

**WIRING DIAGRAM**

MODEL: RF2-35-HC / RF2-HC

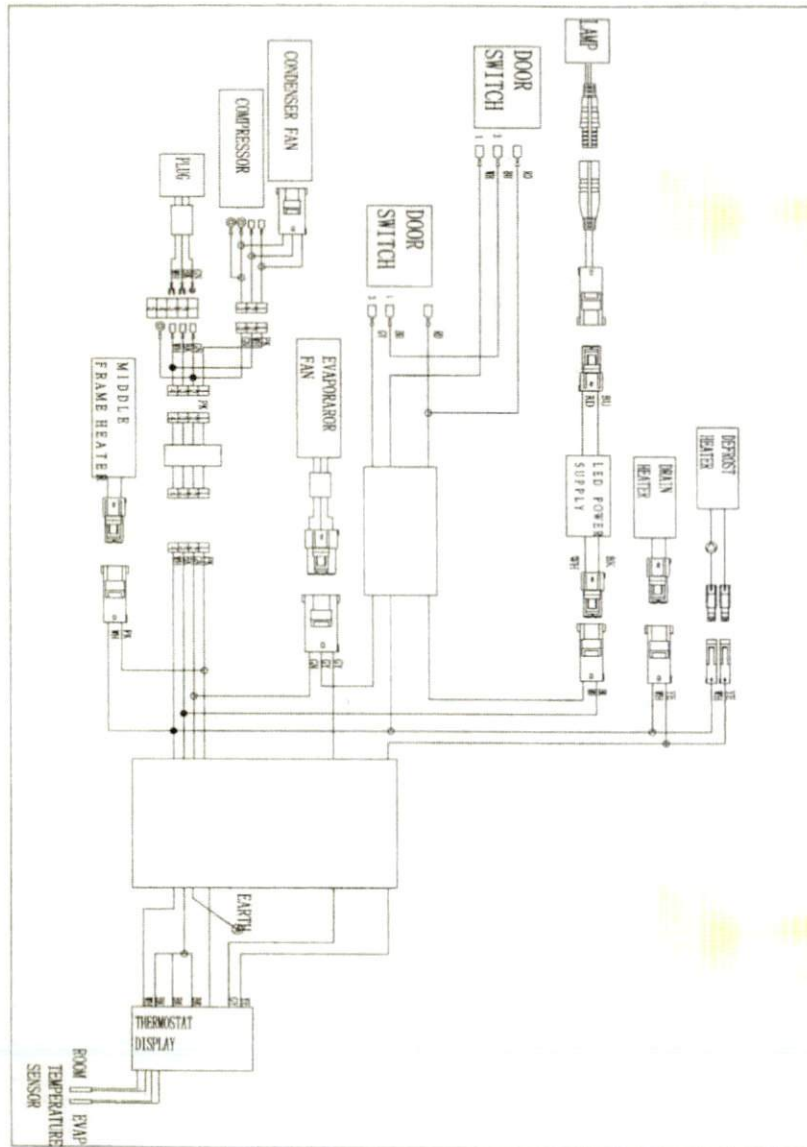

**SPECIFICATION**

SOLID DOOR REFRIGERATORS										
MODEL#	V/Hz/Ph	AMPS	STORAGE CAPACIT	HP	SHELF CAPACITY Sq-ft	BTU	CHARGE OZ	SHIP WEIGHT LBS	NEMA PLUG	
RR1-19-HC	115/60/1	3	13	1/5	13.0	1670	2.82	220	5-15P	
RR1-HC	115/60/1	3	23	1/5	14.0	1670	3.0	350	5-15P	
RR2-35-HC	115/60/1	4.5	35	1/4	26.1	2380	3.7	313	5-15P	
RR2-HC	115/60/1	4.5	49	1/4	28.1	2380	3.7	518	5-15P	
RR3-HC	115/60/1	7.5	72	1/2	42.1	3200	5.29	669	5-15P	

GLASS DOOR REFRIGERATORS										
MODEL#	V/Hz/Ph	AMPS	STORAGE CAPACIT	HP	SHELF CAPACITY Sq-ft	BTU	CHARGE OZ	SHIP WEIGHT LBS	NEMA PLUG	
RR1G-HC	115/60/1	3	23	1/5	14.0	1670	3.0	350	5-15P	
RR2G-HC	115/60/1	4.5	49	1/4	28.1	1670	3.7	518	5-15P	

SOLID DOOR FREEZERS										
MODEL#	V/Hz/Ph	AMPS	STORAGE CAPACIT	HP	SHELF CAPACITY Sq-ft	BTU	CHARGE OZ	SHIP WEIGHT LBS	NEMA PLUG	
RF1-19-HC	115/60/1	5	13	1/2	13.0	2000	3.53	225	5-15P	
RF1-HC	115/60/1	8	23	1/2	14.0	2000	3.88	364	5-15P	
RF2-35-HC	115/60/1	9	35	1	26.1	3650	5.29	320	5-15P	
RF2-HC	115/60/1	9	49	1	28.1	3650	5.29	568	5-15P	
RF3DV-HC	115/208-230/60/1	9	72	1-1/4	42.1	4500	5.29	776	L14-20P	

**CONTENTS**

RECEIVING & INSPECTING EQUIPMENT.....4  
 SPECIFICATIONS.....5  
 INSTALLATION.....6  
 OPERATION.....7  
 MAINTENANCE.....9  
 WIRING DIAGRAM.....11

All rights reserved. Reproduction without written permission is prohibited.

**SERIAL NUMBER INFORMATION**

The serial number of all self-contained refrigerators and freezers is located inside the unit on the left hand side near the top on the wall.

Always have the serial number of your unit available when calling for parts or service.

This manual covers standard units only. If you have a custom unit, consult the customer service department at the number listed on the last page.

**RECEIVING AND INSPECTING THE EQUIPMENT**

Even though most equipment is shipped crated, care should be taken during unloading so the equipment is not damaged while being moved into the building.

1. Visually inspect the exterior of the package and skid or container. Any damage should be noted and reported to the delivering carrier immediately.
2. If damaged, open and inspect the contents with the carrier.
3. In the event that the exterior is not damaged, yet upon opening, there is concealed damage to the equipment, notify the carrier. Notification should be made verbally as well as in written form.
4. Request an inspection by the shipping company of the damaged equipment. This should be done within 10 days from receipt of the equipment.
5. Be certain to check the compressor compartment housing and visually inspect the refrigeration package. Be sure lines are secure and base is still intact.
6. Freight carriers can supply the necessary damage forms upon request.
7. Retain all crating material until an inspection has been made or waived.

**WIRING DIAGRAM**

MODEL: RF3DV-HC

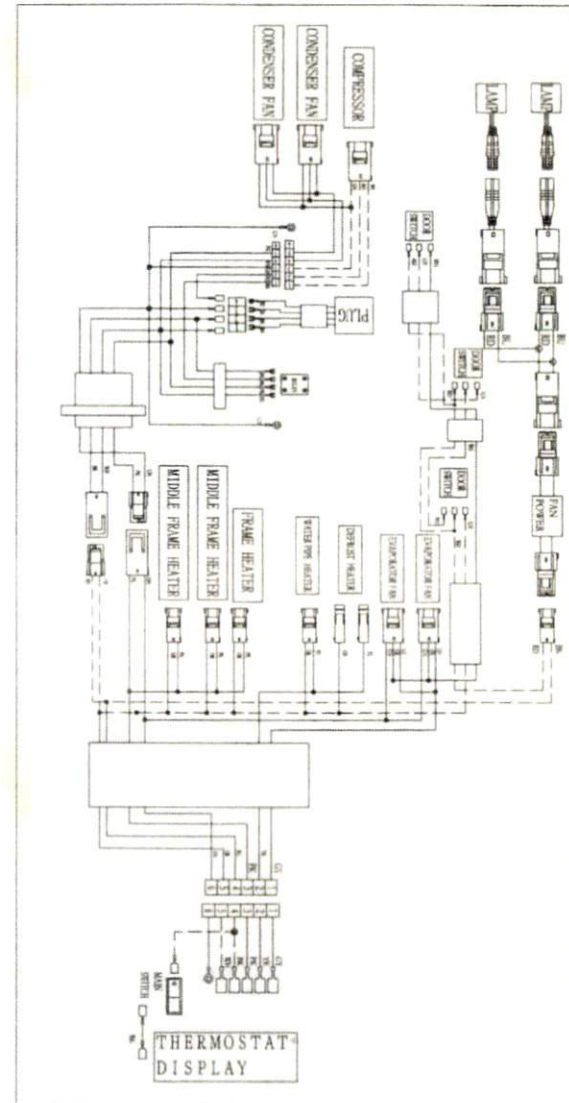

## Service and Installation Manual

with the regulations of local authorities.

The key for appliance electric box should be safe kept by qualified persons in order to avoid a hazard



Warning: Risk of fire / flammable materials

**WARNING:** Keep ventilation openings, in the appliance enclosure or in the built-in structure, clear of obstruction.

**WARNING:** Do not use mechanical devices or other means to accelerate the defrosting process, other than those recommended by the manufacturer.

**WARNING:** Do not damage the refrigerant circuit.

**WARNING:** Do not use electrical appliances inside the food storage compartments of the appliance, unless they are of the type recommended by the manufacturer.

Handling, moving, and use of the refrigerator or freezer to avoid either damaging the refrigerant tubing, or increasing the risk of a leak

L'opération, le mouvement et l'utilisation du réfrigérant ou le congélateur doivent éviter les dommages du tuyau réfrigérant ou le risque de la fuite.

Caution – Risk of Fire or Explosion due to Flammable Refrigerant Used. Follow Handling Instructions Carefully in Compliance with U.S. Government Regulations.

Component parts shall be replaced with like components and that servicing shall be done by factory authorized service personnel, so as to minimize the risk of possible ignition due to incorrect parts or improper service.

Les pièces de rechange doivent être remplacées par les composants relatifs et les opérations doivent être faites par les professionnels afin de minimiser le risque d'allumage à cause des parts incorrects ou de opérations impropres.

CAUTION – Risk Of Fire Or Explosion Due To Puncture Of Refrigerant Tubing; Follow Handling Instruction Carefully. Flammable Refrigerant Used

**DANGER:** Risk of child entrapment. Before you throw away your old refrigerator or freezer:

Take off the doors

Leave the shelves in place so that children may not easily climb inside.

**WIRING DIAGRAM**

MODEL: RF1-19-HC

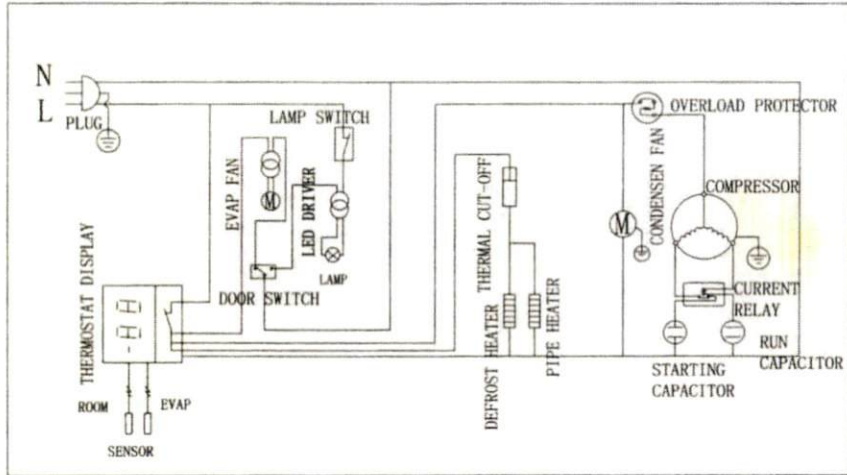

MODEL: RF1-HC

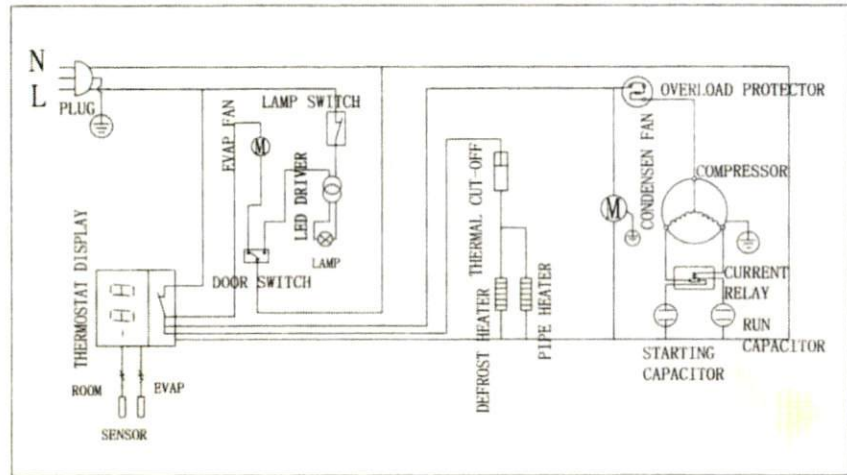

**WIRING DIAGRAM**

MODEL: RF2-HC

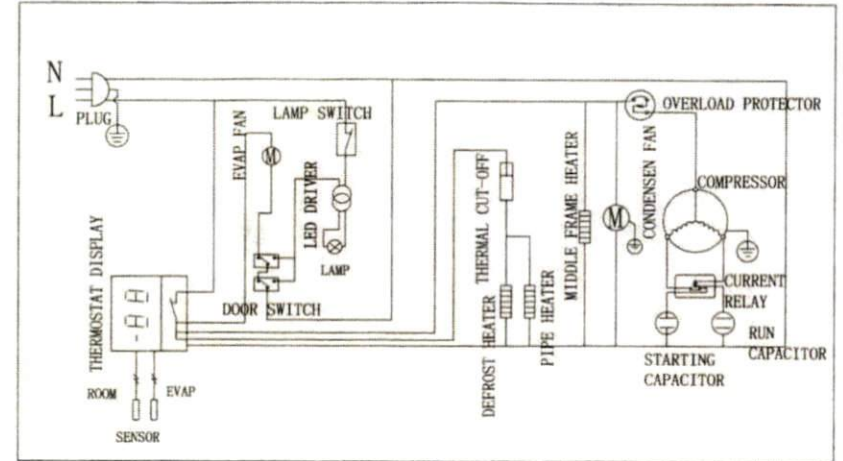

MODEL: RF3DV-HC

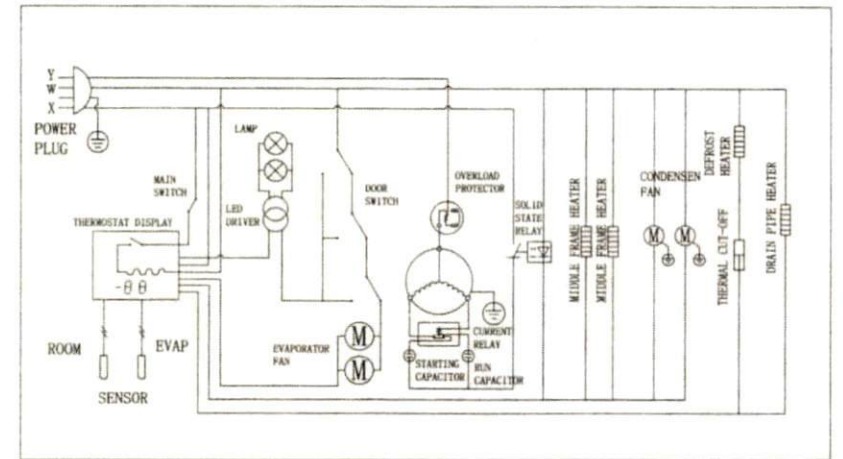



**WIRING DIAGRAM**

MODEL: RR1-19-HC

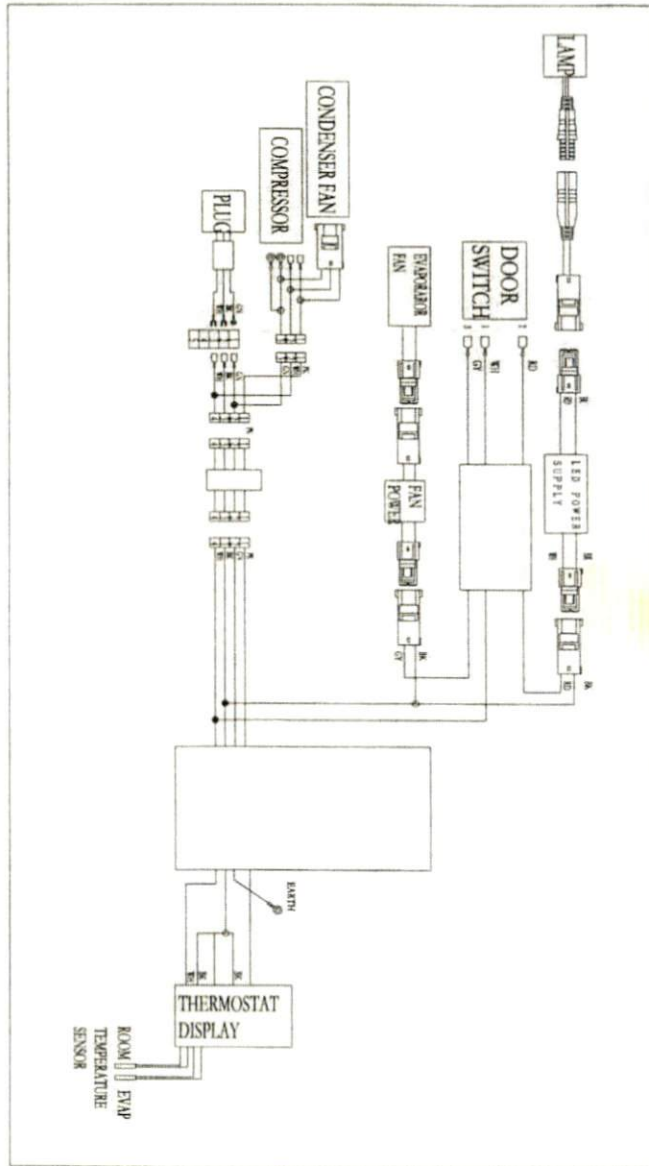

**WIRING DIAGRAM**

MODEL: RR2G-HC

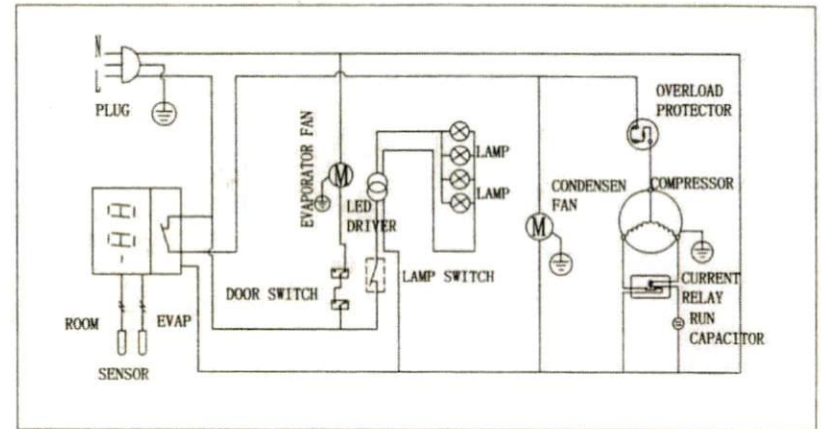

MODEL: RR3-HC

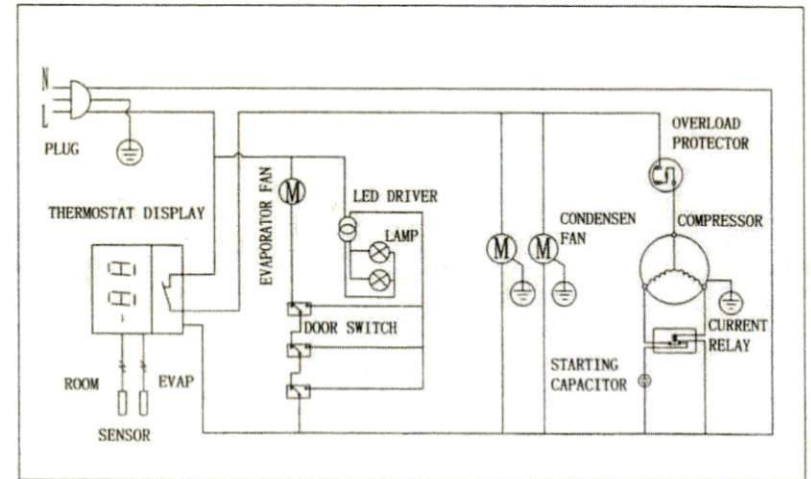

**WIRING DIAGRAM**

MODEL: RR1G-HC

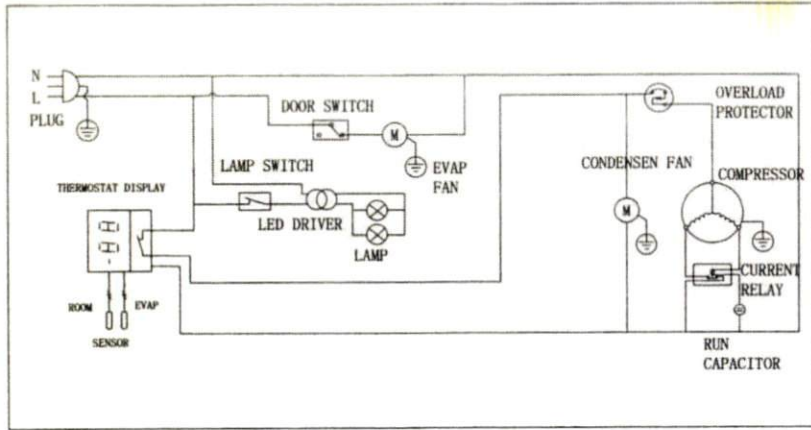

MODEL: RR2-35-HC / RR2-HC

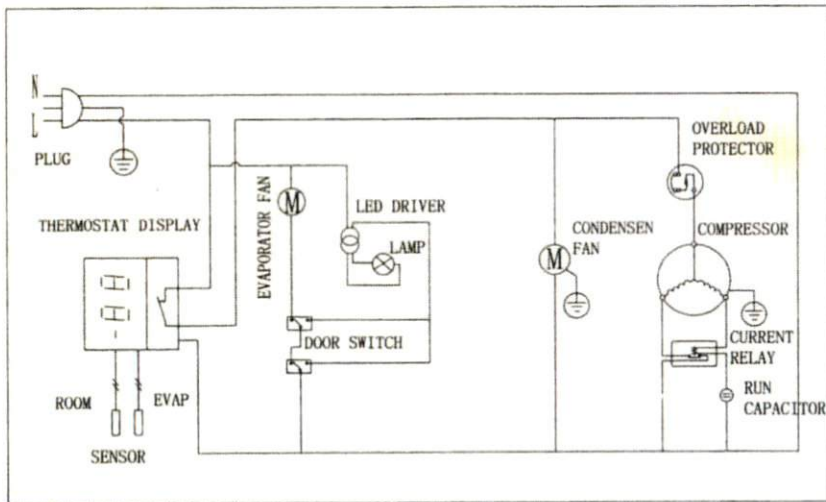

**WIRING DIAGRAM**

MODEL: RR1-HC

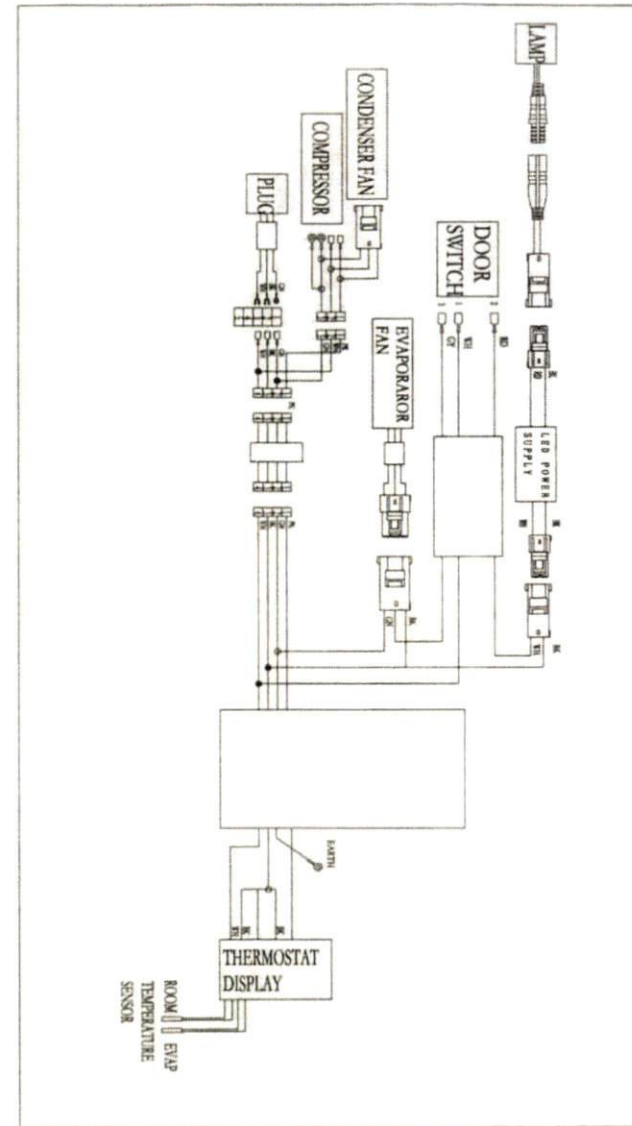

**WIRING DIAGRAM**

MODEL: RR1G-HC

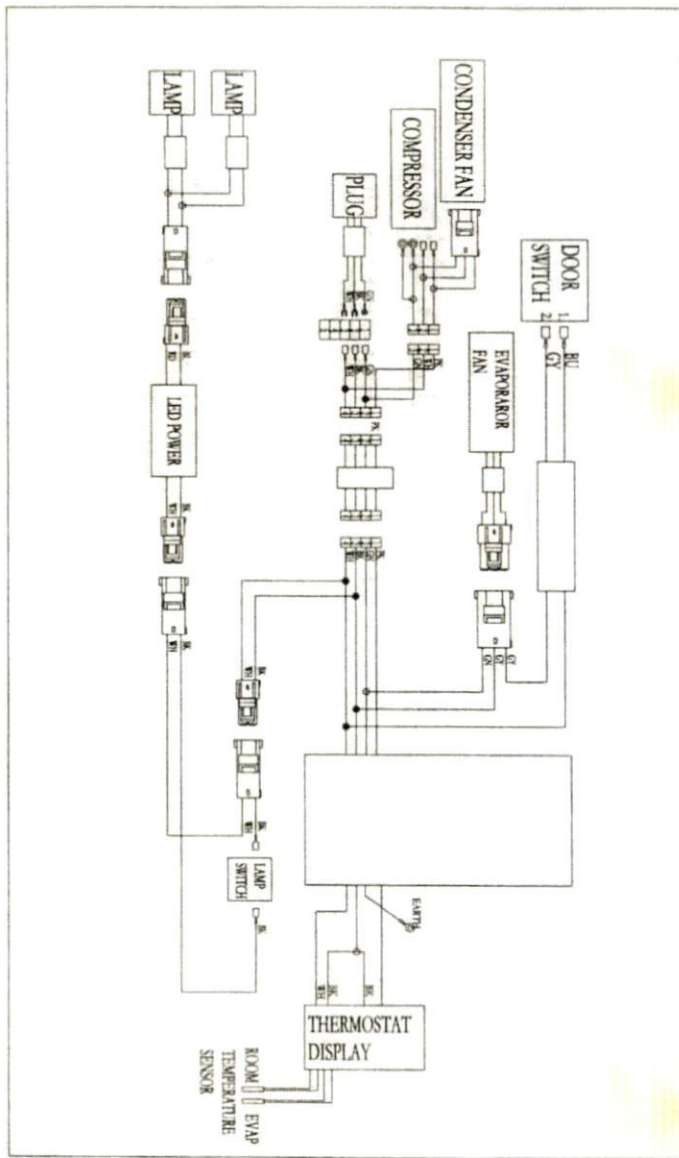

**WIRING DIAGRAM**

MODEL: RR1-19-HC

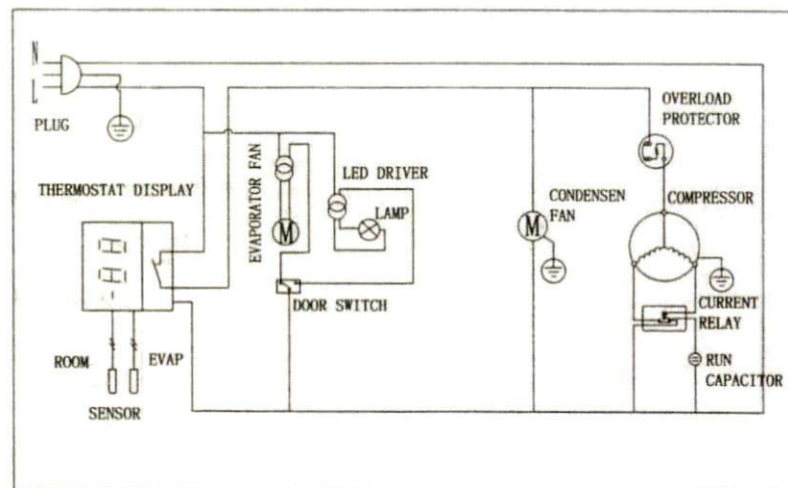

MODEL: RR1-HC

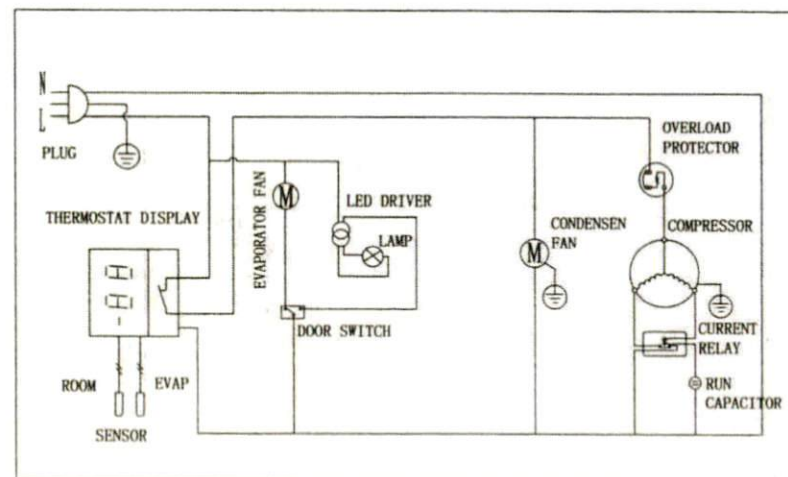

# GLOBE FRYER

*GLOBE*  
*2153 DRYDEN RD.*  
*DAYTON, OH 45439*  
*937-299-5493*

A product with the GLOBE name incorporates the best in durability and low maintenance. We all recognize, however, that replacement parts and occasional professional service may be necessary to extend the useful life of this unit. When service is needed, contact a GLOBE Authorized Service Agency, or your dealer. To avoid confusion, always refer to the model number, serial number, and type of your unit.



## LIMITED ORIGINAL COMMERCIAL EQUIPMENT WARRANTY FOR THE GFF SERIES GAS FRYERS

GLOBE warrants the GFF Gas Fryer to be free of defects in materials and workmanship for a period of 1 year from the date of original installation.

This Warranty is subject to the following conditions and limitations:

1. This warranty is limited to product(s) sold by GLOBE to the original user in the continental United States and Canada.
2. Original installation must occur within 18 months of date of manufacture, and proof of the installation must be provided to GLOBE.
3. The liability of GLOBE is limited to the repair or replacement of any part found to be defective.
4. GLOBE will bear normal labor charges incurred in the repair or replacement of a warranted piece of equipment within 50 miles (80 kilometers) of an authorized service agency. Time and travel charges in excess of 50 miles (80 kilometers) will be the responsibility of the person or firm requesting the service.
5. This warranty does not apply to any product(s) which have not been installed in accordance with the directions published in the appropriate installation and operation manuals. GLOBE will bear no responsibility or liability for any product(s) which have been mishandled, abused, misapplied, misused, subject to harsh chemical action, (chlorinated or sulfate products), or poor water quality, field modified by unauthorized personnel, damaged by flood, fire, or other acts of nature, or which have altered or missing serial numbers.
6. GLOBE does not recommend or authorize the use of any product(s) in a non-commercial application, including but not limited to residential use. The use or installation of product(s) in non-commercial applications renders all warranties, expressed or implied, including the warranties of MERCHANTABILITY and FITNESS FOR A PARTICULAR PURPOSE, null and void, including any responsibility for damage, cost and legal actions resulting from the use or installation of product(s) in any non-commercial setting.
7. Adjustments such as calibrations, leveling, tightening of fasteners or utility connections normally associated with original installation are the responsibility of the installer and not that of GLOBE.
8. Exception to the 1 year warranty period is as listed:  
Fry Tanks:  
If tank is found to be leaking within the first year of operation from date of installation and verified by an authorized service agency, the entire GFF-fryer will be replaced. Replacement fryer will be warranted for the balance of the original warranty. Original purchased replacement parts manufactured by GLOBE will be warranted for 90 days from the parts invoice date. This warranty is for parts cost only, and does not include freight or labor charges. Exceptions are stainless steel fry tanks which will be warranted as stated in item 8.
9. This states the exclusive remedy against GLOBE relating to the product(s), whether in contract or in tort or under any other legal theory, and whether arising out of warranties, representations, instructions, installations or defects from any cause. GLOBE shall not be liable, under any legal theory, for loss of use, revenue or profit, or for substituted use or performance, or for incidental, indirect, or special or consequential damages or for any other loss of cost of similar type.
10. THIS WARRANTY AND THE LIABILITIES SET FORTH HEREIN ARE EXCLUSIVE AND IN LIEU OF ALL OF THEIR LIABILITIES AND WARRANTIES, EXPRESSED OR IMPLIED, INCLUDING BUT NOT LIMITED TO, IMPLIED WARRANTIES OR MERCHANTABILITY AND FITNESS FOR PARTICULAR PURPOSE AND CONSTITUTES THE ONLY WARRANTY OF GLOBE WITH RESPECT TO THE PRODUCT(S).

# OPERATOR'S MANUAL

## GFF Series Fryers



**Model GFF35G**  
**GFF35PG**  
(3 Burner Fryer)

**Model GFF50G**  
**GFF50PG**  
(4 Burner Fryer)

**Model GFF80G**  
**GFF80PG**  
( 5 Burner Fryer)

**! WARNING**

Improper installation, adjustment, alteration, service or maintenance can cause property damage, injury or death. Read the installation, operating and maintenance instructions thoroughly before installing or servicing this equipment.

In order to provide the best service, ATOSA Catering Equipment INC. requests that please register your warranty online at [www.atosausa.com](http://www.atosausa.com) For any service issues, please kindly contact us at

Email: [warranty@atosausa.com](mailto:warranty@atosausa.com)

Or

Toll Free: +1-800-683-8660

## **Gas Countertop Griddles Operating Instructions**



Before you begin, please read these instructions carefully to use this product correctly, to make the product perform ideally, and to avoid hazards.

**Models: ATTG-24 / ATTG-36 / ATTG-48**

## SAFETY PRECAUTIONS

Before installing and operating this equipment, be sure everyone involved in its operation is fully trained and aware of precautions. Accidents and problems can be caused by failure to follow fundamental rules and precautions.

The following symbols, found throughout this manual, alert you to potentially dangerous conditions to the operator, service personnel, or to the equipment.

 <b>DANGER</b>	This symbol warns of immediate hazards that will result in severe injury or death.
 <b>WARNING</b>	This symbol refers to a potential hazard or unsafe practice that could result in injury or death.
 <b>CAUTION</b>	This symbol refers to a potential hazard or unsafe practice that could result in injury, product damage, or property damage.
<b>NOTICE</b>	This symbol refers to information that needs special attention or must be fully understood, even though not dangerous.

 **WARNING**  
**FIRE HAZARD**  
**FOR YOUR SAFETY**

**Do not store or use gasoline or other flammable vapors and liquids in the vicinity of this or any other appliance.**

**Keep area around appliances free and clear of combustibles.**

**Purchaser of equipment must post in a prominent location, detailed instructions to be followed in the event the operator smells gas. Obtain the instructions from the local gas supplier.**

 **WARNING**  
**BURN HAZARD**

Contact with hot oil will cause severe burns. Always use caution. Oil at 200°F is more dangerous than boiling water.

 **WARNING**

In the event a gas odor is detected, shut down equipment at the combination gas valve and contact the local gas company or gas supplier for service.



**NOTICE**

GLOBE Fryers are intended for commercial use only. Not for household use.

Warranty will be void if service work is performed by other than a qualified technician, or if other than genuine GLOBE replacement parts are installed.

Be sure this Operator's Manual and important papers are given to the proper authority to retain for future reference.

Congratulations! You have purchased one of the finest pieces of commercial cooking equipment on the market.

You will find that your new equipment, like all GLOBE equipments, has been designed and manufactured to meet the toughest standards in the industry. Each piece of GLOBE equipment is carefully engineered and designs are verified through laboratory tests and field installations. With proper care and field maintenance, you will experience years of reliable, trouble-free operation. **For best results, read this manual carefully.**

RETAIN THIS MANUAL FOR FUTURE REFERENCE.

**MODELS**

This manual is for GLOBE Fryers with 35-lb (GFF35), 55-lb (GFF50) and 80-lb (GFF80) capacity frypots. The capacity is described on the serial plate that is located inside the front door on the left side.

**Table of Contents**

Specifications ..... 4

Installation ..... 6

Operation ..... 12

Cooking Hints ..... 14

Cleaning ..... 14

Service (for authorized service technician only)..... 16

Parts ..... 20

Read these instructions carefully before attempting installation. Installation and initial startup should be performed by a qualified installer. Unless the installation instructions for this product are followed by a qualified service technician (a person experienced in and knowledgeable with the installation of commercial gas and/or electric cooking equipment) then the terms and conditions on the Manufacturer's Limited Warranty will be rendered void and no warranty of any kind shall apply.

# GLOBE FRYER

*GLOBE*  
*2153 DRYDEN RD.*  
*DAYTON, OH 45439*  
*937-299-5493*

A product with the GLOBE name incorporates the best in durability and low maintenance. We all recognize, however, that replacement parts and occasional professional service may be necessary to extend the useful life of this unit. When service is needed, contact a GLOBE Authorized Service Agency, or your dealer. To avoid confusion, always refer to the model number, serial number, and type of your unit.



## LIMITED ORIGINAL COMMERCIAL EQUIPMENT WARRANTY FOR THE GFF SERIES GAS FRYERS

GLOBE warrants the GFF Gas Fryer to be free of defects in materials and workmanship for a period of 1 year from the date of original installation.

This Warranty is subject to the following conditions and limitations:

1. This warranty is limited to product(s) sold by GLOBE to the original user in the continental United States and Canada.
2. Original installation must occur within 18 months of date of manufacture, and proof of the installation must be provided to GLOBE.
3. The liability of GLOBE is limited to the repair or replacement of any part found to be defective.
4. GLOBE will bear normal labor charges incurred in the repair or replacement of a warranted piece of equipment within 50 miles (80 kilometers) of an authorized service agency. Time and travel charges in excess of 50 miles (80 kilometers) will be the responsibility of the person or firm requesting the service.
5. This warranty does not apply to any product(s) which have not been installed in accordance with the directions published in the appropriate installation and operation manuals. GLOBE will bear no responsibility or liability for any product(s) which have been mishandled, abused, misapplied, misused, subject to harsh chemical action, (chlorinated or sulfate products), or poor water quality, field modified by unauthorized personnel, damaged by flood, fire, or other acts of nature, or which have altered or missing serial numbers.
6. GLOBE does not recommend or authorize the use of any product(s) in a non-commercial application, including but not limited to residential use. The use or installation of product(s) in non-commercial applications renders all warranties, expressed or implied, including the warranties of MERCHANTABILITY and FITNESS FOR A PARTICULAR PURPOSE, null and void, including any responsibility for damage, cost and legal actions resulting from the use or installation of product(s) in any non-commercial setting.
7. Adjustments such as calibrations, leveling, tightening of fasteners or utility connections normally associated with original installation are the responsibility of the installer and not that of GLOBE.
8. Exception to the 1 year warranty period is as listed:  
Fry Tanks:  
If tank is found to be leaking within the first year of operation from date of installation and verified by an authorized service agency, the entire GFF-fryer will be replaced. Replacement fryer will be warranted for the balance of the original warranty. Original purchased replacement parts manufactured by GLOBE will be warranted for 90 days from the parts invoice date. This warranty is for parts cost only, and does not include freight or labor charges. Exceptions are stainless steel fry tanks which will be warranted as stated in item 8.
9. This states the exclusive remedy against GLOBE relating to the product(s), whether in contract or in tort or under any other legal theory, and whether arising out of warranties, representations, instructions, installations or defects from any cause. GLOBE shall not be liable, under any legal theory, for loss of use, revenue or profit, or for substituted use or performance, or for incidental, indirect, or special or consequential damages or for any other loss of cost of similar type.
10. THIS WARRANTY AND THE LIABILITIES SET FORTH HEREIN ARE EXCLUSIVE AND IN LIEU OF ALL OF THEIR LIABILITIES AND WARRANTIES, EXPRESSED OR IMPLIED, INCLUDING BUT NOT LIMITED TO, IMPLIED WARRANTIES OR MERCHANTABILITY AND FITNESS FOR PARTICULAR PURPOSE AND CONSTITUTES THE ONLY WARRANTY OF GLOBE WITH RESPECT TO THE PRODUCT(S).



## HIGH LIMIT CONTROL

GLOBE Fryers are equipped with a secondary heat control that prevents the oil temperature from rising above 450°F. (Because of the accuracy tolerance of the sensor, the oil temperature may reach as high as 475°F.)

In the event the fryer shuts down due to this condition, the oil must be cooled to below 400°F before the pilot burner can be re-ignited. When the oil has cooled, use the "Lighting" procedure on page 12 to place the fryer back in operation. If the problem persists, contact your GLOBE Service Representative or the GLOBE Service Department.

## COOKING HINTS

### USER TIPS

- Smoking oil means that the temperature is too high, or that the oil has broken down.
- Gum in frypot denotes a need for thorough cleaning (see "Weekly Cleaning" on page 15)
- Use different oil for oily foods (mackerel, nutmeg, etc.) than for foods with water-soluble flavors (potatoes, onions, etc.).
- Taste cool oil for quality. Replace it regularly.
- Poor oil cannot produce good food.

## CLEANING

GLOBE equipment is constructed with the best quality materials and is designed to provide durable service when properly maintained. To expect the best performance, your equipment must be maintained in good condition and cleaned daily. Naturally, the frequency and extent of cleaning depends on the amount and degree of usage.

Following daily and more extensive periodic maintenance procedures will increase the life of your equipment. Climatic conditions (e.g., salt air) may result in the need for more thorough and more frequent cleaning in order to keep equipment performing at optimal levels.



### **WARNING: BURN HAZARD**

If necessary to move the fryer for cleaning, etc., drain oil first to avoid death or serious injury.



### **WARNING**

If disconnection of the restraint is necessary to move the appliance for cleaning, etc., reconnect it when the appliance is moved to its originally installed position.

SERVICE

### DAILY CLEANING

1. Turn thermostat knob to "OFF" position.
2. Place hot-oil in a safe container under the drain and drain the frypot completely.
3. Remove the basket support frame (if applicable) and flush out any sediment remaining in the frypot with a little hot oil.



- Wipe off the basket support frame and the inside of the frypot with a clean cloth.

**! CAUTION**

*SOME AREAS OF THE FRYPOT MAY BE HOT!*

- Close drain valve and strain the oil back into the frypot through several thicknesses of cheesecloth, or filter it back using a filter machine.
- Replace the basket support frame (if applicable)
- Add oil or shortening to MIN oil level mark on rear of frypot.
- To resume cooking, turn the combination gas valve knob to "ON" position.

### WEEKLY CLEANING

- Follow steps 1 through 4 of the Daily Cleaning procedure (see previous section).
- Close drain valve and fill frypot with a solution of warm water and boil-out compound
- Relight the fryer and bring the solution to a gentle boil for at least five minutes.
- Turn off main burners and let the solution stand until the gum deposits are softened and the carbon spots and burned grease spots can be rubbed off.
- Scrub the frypot walls and heat tubes, then drain out frypot and rinse it with clean water.
- Refill the frypot with clean water and boil again.
- Turn off gas and drain and rinse well until clean.
- Wipe dry with a clean cloth.
- Refill as specified in the "Filling the Frypot" section (see page 13).

### MONTHLY CLEANING

- Perform the Weekly Cleaning procedure (see previous section).
- Clean around burner and orifices if lint has accumulated.
- Visually check that burner carry-over ports are unobstructed.

### CLEANING STAINLESS STEEL SURFACES

To remove normal dirt, grease and product residue from stainless steel use ordinary soap and water (with or without detergent) applied with a sponge or cloth. Dry thoroughly with a clean cloth. Never use vinegar or any corrosive cleaner.

To remove grease and food splatter or condensed vapors that have baked on the equipment apply cleanser to a damp cloth or sponge and rub cleanser on the metal in the direction of the polishing lines on the metal. Rubbing cleanser, as gently as possible, in the direction of the polished lines will not mar the finish of the stainless steel. NEVER RUB WITH A CIRCULAR MOTION. Soil and burnt deposits that do not respond to the above procedure can usually be removed by rubbing the surface with SCOTCH-BRITE™ scouring pads or STAINLESS scouring pads. DO NOT USE ORDINARY STEEL WOOL, as any particles left on the surface will rust and further spoil the appearance of the finish. NEVER USE A WIRE BRUSH, STEEL SCOURING PADS (EXCEPT STAINLESS), SCRAPER, FILE OR OTHER STEEL TOOLS. Surfaces that are marred collect dirt more rapidly and become more difficult to clean. Marring also increases the possibility of corrosive attack. Refinishing may then be required.

Darkened areas, called "heat tint," sometimes appear on stainless steel surfaces where the area has been subjected to excessive heat. These darkened areas are caused by thickening of the protective surface of the stainless steel and are not harmful. Heat tint can normally be removed by the above cleaning techniques, but tint which does not respond to that procedure calls for a vigorous scouring in the direction of the polish lines, using SCOTCH-BRITE™ scouring pads or a STAINLESS scouring pad in combination with a powered

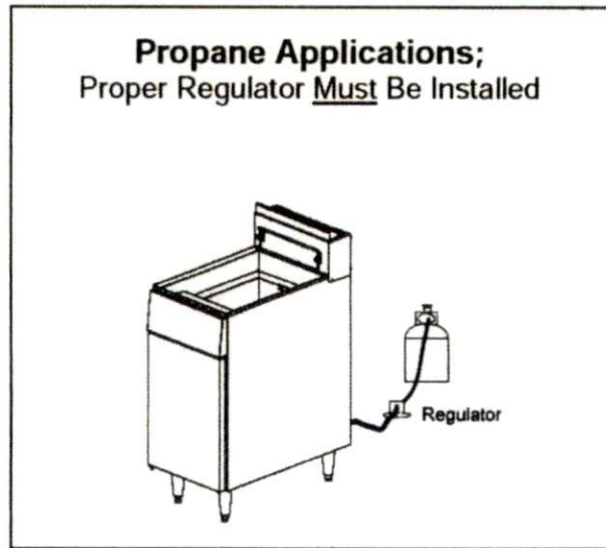

PHOTO 1

# OPERATION

## LIGHTING

**! CAUTION**

*IF YOU SMELL GAS DURING THE LIGHTING PROCEDURE, IMMEDIATELY SHUT OFF THE GAS SUPPLY UNTIL THE LEAK HAS BEEN CORRECTED.*

Open the burner compartment door and do the following:

1. Turn thermostat to "OFF"
2. Press down the knob of the combination gas valve, turn it counterclockwise to the "PILOT" position (shown), and continue to press the knob down.

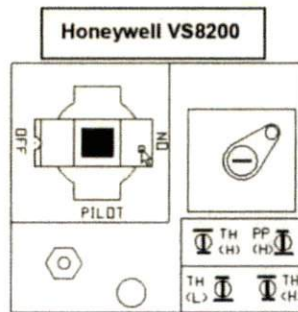
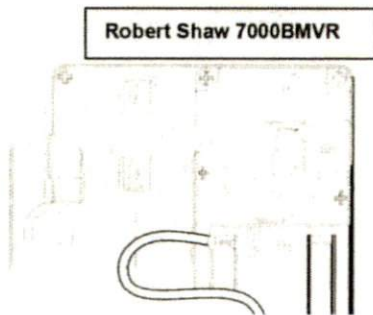

3. While pressing the knob down, use a lit match to ignite the pilot. Continue to press the knob down for about 30 seconds. If the pilot does not stay lit when the knob is released, repeat the lighting procedure and keep the knob down longer. Adjustment of pilot flame may be necessary.
4. When the pilot stays lit, turn the knob counterclockwise to the "ON" position. Do not press down on the knob in this step.
5. Do NOT turn the thermostat "ON" until the frypot is filled with oil or solid shortening.
6. Once the frypot is filled with shortening, set the thermostat to the desired temperature

SERVICE



## FILLING THE FRYPOT

1. Close drain valve completely before filling the frypot.
2. When the fryer is new, fill the frypot with water and clean thoroughly (see "Weekly Cleaning" on page 15) in order to remove protective coatings and any foreign matter.
3. The recommended solid shortening capacity for the frypot (35, 55 or 75lbs) is described on the serial plate (which is located inside the front door).
4. Remove the basket support frame when filling the frypot with solid shortening.
5. When solid shortening is used, be careful not to bend, break, or twist the thin capillary wires of the sensing elements located in the frypot.
6. Pack solid shortening into the zone below the tubes, all spaces between the tubes, and at least an inch above the top of the tubes before lighting the fryer. If any air spaces are left around the heat tube surfaces when the heat is turned on, the tube surfaces will become red hot, burn the solid shortening, weaken the frypot, and could result in a fire.

### CAUTION

*NEVER ATTEMPT TO MELT A SOLID BLOCK OF SHORTENING ON TOP OF THE HEAT TUBES.  
NEVER START THE BURNERS WHEN THE FRYPOT IS EMPTY.*

7. To prevent burning or scorching the solid shortening, keep the thermostat set at the lowest temperature until all the solid shortening between and above the tubes has been melted. Additional solid shortening can then be added until the desired frying depth has been reached.
8. Replace the basket support frame over the frypot heat tubes.

## SHUTDOWN PROCEDURE

Standby: Turn knob on the combination gas valve to the "PILOT" position. At this setting, only the pilot burner will remain ignited.

Complete Shutdown: Turn knob on the combination gas valve clockwise, press down on the knob and continue to turn to the "OFF" position.

## RELIGHTING

### WARNING

In the event of a main burner ignition failure, a five minute purge period must be observed prior to re-establishing the ignition source.

1. Shut off all gas.
2. Wait five minutes.
3. Follow the "Lighting" procedure described on page 12.

## AUTOMATIC PILOT VALVE

The Automatic Pilot Valve provides an automatic safety shutoff for the fryer when the pilot flame is extinguished. When the pilot flame is burning, the valve is held open electromagnetically by the electrical current from a thermopile in the pilot flame. When the pilot flame goes out, generation of current ceases and the valve closes automatically.

Notice:

1. Pressure maintaining valve connects with air intake must be installed by authorized and licensed technicians to ensure interface tightness.
2. Screw the hex nut (Fig.8) before connect air intake, ensure gas mark (Fig.9) on the plastic core match with connected gas source, if not, then pull out the plastic core and change another head, insert it again. The same as exchanging gas source.
3. When exchange gas source, use the main fire orifice (Fig.10) in the accessories. Follow rules of 8.5.

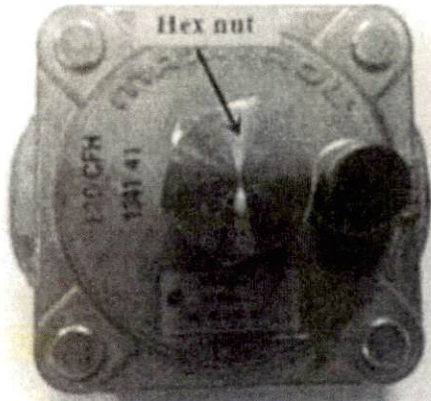

Fig. 8

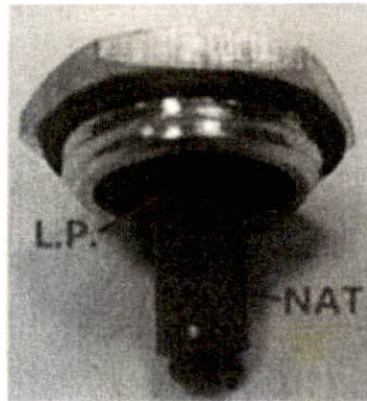

Fig. 9

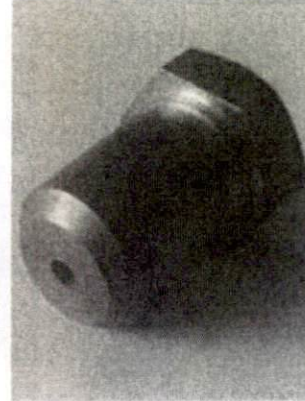

Fig. 10



Conforms to ANSI STD Z83.11-2016  
Certified to CSA STD 1.8-2016  
Conforms to NSF/ANSI STD.4

Our products have the advantages of good durability and low maintenance charge. But to update some components and necessary maintenance, can prolong life length of the products. Contact the dealer for assistance.



## 10. Troubleshooting

<Table 3>

Problems	Possible causes	Problem solving
Not lighting	1. Insufficient gas pressure in pipe	1. Contact the local gas supply dept.
	2. Nozzle occlusion	2. Dredge nozzle
Ignite the pilot light but not the main fire	1. Insufficient gas pressure in pipe	1. Contact the local gas supply dept.
	2. The main fire nozzle occlusion	2. Dredge nozzle
	3. Gas control valves have problems	3. Change gas control valves
	4. The pilot light and the main fire's distance is too far	4. Adjust the distance of them
	5. Flame is too low	5. Adjust the height of the pilot light
Close gas and heard a sound of fire	1. Insufficient gas pressure in pipe	1. Contact the local gas supply dept.
	2. Not match nozzle aperture with gas resources	2. Adjust nozzle diameter
	3. Flow of connection pipe is not enough	3. Increase pipe's allowable flow
	4. Damper opening degree is too large	4. Adjust damper
Yellow flame and black smoke	1. Use the gas of bottom	1. Change gas
	2. Not match nozzle diameter with gas resources	2. Adjust nozzle diameter
	3. Not enough air to ignite	3. Increase damper opening degree
	4. In the peak of using gas, sources of gas float heavy	4. Turn down valves flow. Turn it up after the peak

The problems mentioned above are only for reference. If any fault occurs, please stop using, and contact technicians to check and repair. Safety first, turn off the power and gas supply before maintenance.



Step 4: Check Clearances and Ventilation

Select a firm, level location for your fryer. Leave clearance, whenever possible, so that access from the rear is possible to permit cleaning. If the unit is to be set on non-combustible flooring, such as a concrete slab, 3 inches minimum toe room must be provided to prevent restriction of the air opening in the bottom of the unit.

**! WARNING**

There must be adequate clearance between fryer(s) and construction. Clearance must also be provided in front for servicing and for operation.

Minimum Clearances:

	From Combustible Construction
Sides	6 inches
Rear	6 inches

*ALL GLOBE FRYERS SHALL BE INSTALLED WITH AT LEAST A 16 INCH SPACE BETWEEN THE FRYER AND SURFACE FLAMES FROM ADJACENT EQUIPMENT. A FLAME GUARD IS ACCEPTABLE IF ALLOWED UNDER LOCAL CODE.*

No additional side and rear clearance is required for service as the fryer is serviceable from the front.

INSTALLATION

**! WARNING**

Improper ventilation can result in personal injury or death. Ventilation that fails to properly remove flue products can cause headaches, drowsiness, nausea, or could result in death.

Unit Must be installed under a ventilation hood

All units must be installed in such a manner that the flow of combustion and ventilation air is not obstructed. Provisions for adequate air supply must also be provided. Do NOT obstruct the bottom front of the unit, as combustion air enters through this area. Be sure to inspect and clean the ventilation system according to the ventilation equipment manufacturer's instructions.

Due to the variety of problems that can be caused by outside weather conditions, venting by canopies or wall fans is preferred over any type of direct venting. It is recommended that a canopy extend 6" past the appliance and the bottom edge be located 6'6" from the floor. Filters should be installed at an angle of 45° or more from the horizontal. This position prevents dripping of grease and facilitates collecting the run-off grease in a drip pan, unusually installed with a filter. A strong exhaust fan tends to create a vacuum in the room and may interfere with burner performance or may extinguish pilot flames. Fresh air openings approximately equal to the fan area will relieve such a vacuum. In case of unsatisfactory performance on any appliance, check the appliance with the exhaust fan in the "OFF" position. Do this only long enough to check equipment performance, then turn hood back on and let it run to remove any exhaust that may have accumulated during the test.

The exhaust fan should be installed at least 2 feet above the vent opening at the top of the fryer.

Make sure all ventilation meet local code requirement

This unit is not intended to be connected directly to an outside flue.

**Step 5: Gas Connection**

A 3/4" male NPT line for the gas connection is located near the lower right rear corner of the fryer. The serial plate (located inside the front door of the fryer) indicates the type of gas the unit is equipped to burn (natural gas or propane). The fryer should be connected **ONLY** to the type of gas for which it is equipped.

A circuit diagram is located inside the front door of the fryer.

All GLOBE equipment is adjusted at the factory; however, pilot height should be checked at installation and adjusted, if necessary.

For orifice sizes and pressure regulator settings, see the chart on page 4. If the fryer is being installed at over 2,000 feet altitude and that information was not specified when ordered, contact the appropriate authorized GLOBE Service Representative or the GLOBE Service Department. Failure to install with proper orifice sizing will result in poor performance and may void the warranty.

If applicable, the vent line from the gas appliance pressure regulator shall be installed to the outdoors in accordance with local codes or, in the absence of local codes, with the *National Fuel Gas Code, ANSI Z223.1, Natural Gas Installation Code, CAN/CGA-B149.1*, or the *Propane Installation Code, CAN/CGA-B149.2*, as applicable.

An adequate gas supply is imperative. Undersized or low pressure lines will restrict the volume of gas necessary for satisfactory performance. A combination gas valve and pressure regulator, which is provided with each unit, is set to maintain a 4" W.C. manifold pressure for natural gas or 10.0" W.C. manifold pressure for propane gas. However, to maintain these conditions the pressure on the supply line, when all units are operating simultaneously, should not drop below 7" W.C. for natural gas or 11" W.C. for propane gas. Fluctuations of more than 25% on natural gas or 10% on propane gas will create problems and affect burner operating characteristics. A 1/8" tap to measure the manifold pressure is located on the combination gas valve, which is on the burner manifold located directly below the burners inside the cabinet.

Purge the supply line to clean out dust, dirt, or other foreign matter before connecting the line to the unit.

It is recommended that an individual manual shutoff valve be installed in the gas supply line to the unit.

Use pipe joint compound that is suitable for use with both natural and LP gas on all threaded connections.

 **CAUTION**

ALL PIPE JOINTS AND CONNECTIONS MUST BE TESTED THOROUGHLY FOR GAS LEAKS. USE ONLY SOAPY WATER FOR TESTING ON ALL GASES. NEVER USE AN OPEN FLAME TO CHECK FOR GAS LEAKS. ALL CONNECTIONS MUST BE CHECKED FOR LEAKS AFTER THE UNIT HAS BEEN PUT INTO OPERATION. **TEST PRESSURE SHOULD NOT EXCEED 14" W.C.**

 **CAUTION**

*THIS APPLIANCE AND ITS INDIVIDUAL COMBINATION GAS VALVE MUST BE DISCONNECTED FROM THE GAS SUPPLY PIPING SYSTEM DURING ANY PRESSURE TESTING OF THAT SYSTEM AT TEST PRESSURES IN EXCESS OF 14"WC (1/2 PSIG or 3.45 kPa).*

**If the incoming gas pressure is in excess of 14"WC (1/2PSI, 3.45 kPa), a proper step-down regulator will be required. See PHOTO 1 for LP application**

Connect the gas supply directly to the 3/4" male NPT connector located near the lower left rear corner of the fryer. When tightening the supply pipe, be sure to hold the mating connector extending from the unit securely with a wrench. This will prevent any damage or distortion to the internal piping and controls of the unit.

After connecting the gas supply, check again that the fryer is level. Use a long spirit level four ways; across the front and rear of the frypot, and along each edge.