

Harnett County Department of Public Health

PERMIT # EH1901-0003

Operation Permit

New Installation Septic Tank Nitrification Line Repair Expansion

PROPERTY LOCATION: 301 1542 OLD BUIES CREEK RD

Name: (owner) Robert Whittaker

SUBDIVISION THE CREEK

LOT # 4

System Installer: Elison Moore

Basement with plumbing: Garage Number of Bedrooms 3

Type of Water Supply: Community Public Well Distance from well _____ feet

System Type: Pressure Manifold to Existing + NEW LINES Types V and VI Systems expire in 5 years.

(In accordance with Table V a)

Owner must contact Health Department 6 months prior to expiration for permit renewal.

*5 QUICK 4 chambers Added
3 ARC CHAMBERS Replaced*

This system has been installed in compliance with applicable North Carolina General Statutes, Rules for Sewage Treatment and Disposal, and all conditions of the Improvement Permit and Construction Authorization.

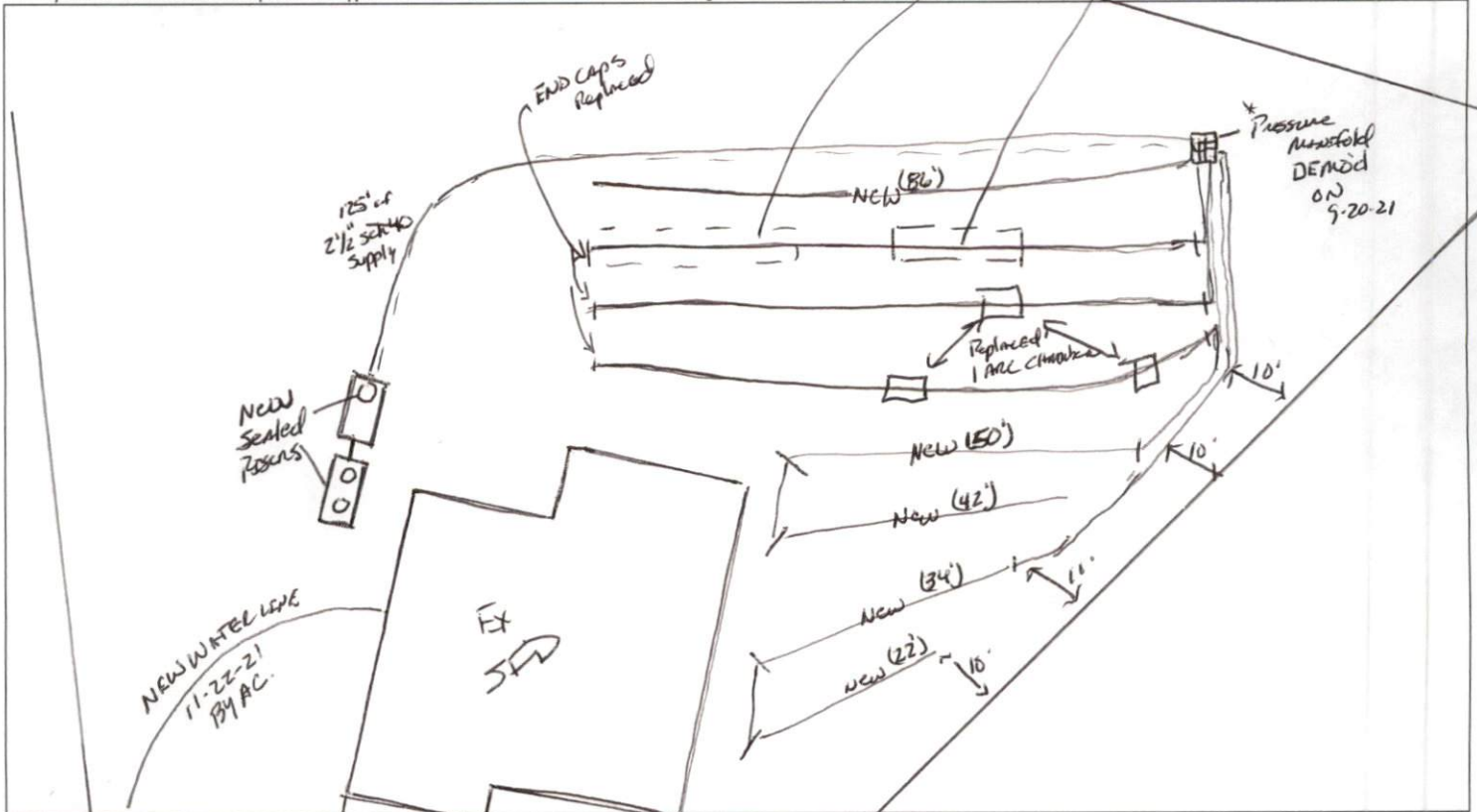

PERMIT CONDITIONS:

- I. Performance: System shall perform in accordance with Rule .1961.
- II. Monitoring: As required by Rule .1961.
- III. Maintenance: As required by Rule .1961. Other: _____
Subsurface system operator required? Yes No
If yes, see attached sheet for additional operation conditions, maintenance and reporting.
- IV. Operation: _____
- V. Other: _____

D-Box Pump Alarm H2O Line PWR Line

Following are the specifications for the sewage disposal system on the above captioned property.
 Type of system: Conventional Other 150' bed on Pressure Manifold Septic Tank: Existing Both sealed with seals gallons Pump Tank: Existing gallons
 Subsurface No. of 3 VANGUARD exact length of each ditch 235 *total added feet width of ditches 3 feet depth of ditches 18" inches
 Drainage Field ditches _____ of each ditch _____ feet
 French Drain Required: _____ Linear feet

Authorized State Agent [Signature] Date 11-23-21

Warrant Court of Justice

Case No. 101
101



11-23-21
 [Signature]
 [Illegible text]

NEED letter for Food Pallet

Pieces water tight - no need letter for Jack

210 sets 125' off supply

3 PACE Chambers

TRANSPOSE DISCONNECT 9-17-20

replaced PACE Chamber on BACK back

- NOTES:
- 1.) Remove existing D-Box and Step Downs.
 - 2.) Contractor shall re-establish vegetation over all disturbed areas.
 - 3.) Damaged chambers shall be replaced.
 - 4.) Leak Test required for existing tanks.
 - 5.) Control Panel shall have elapsed timer and counter.
 - 5.) Base Survey by Others.

* scaled off & water proof
RISKS on Tanks

5
RAUL NAVA Jr
BRITTANY NAVA
DB 3570 PG 991

+ Chamber SHORT + signpost
see FOLL 228744
NEED OR FROM
FOLL 228744
Force spot for
END signpost
MISSING -

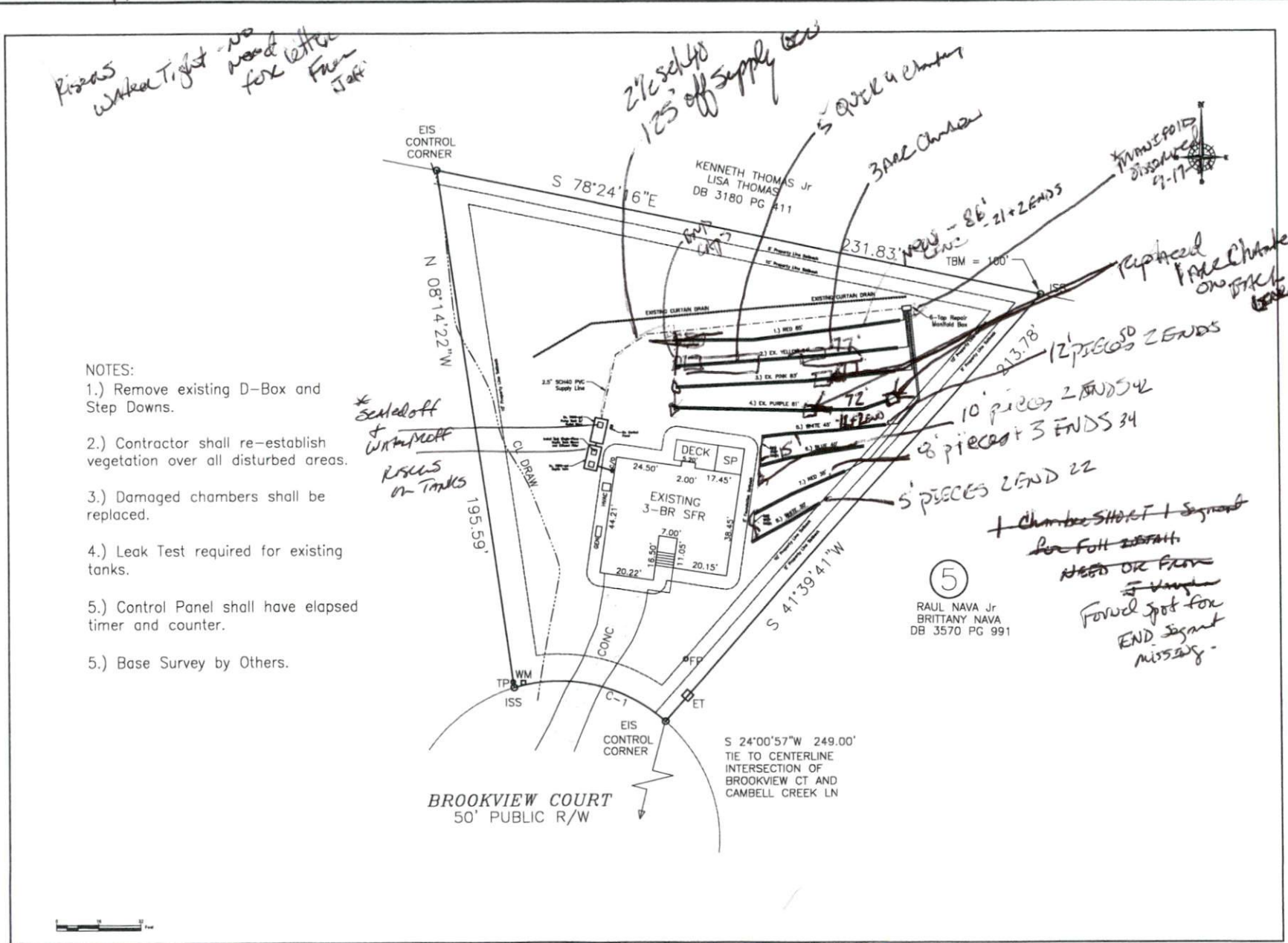

AWT
Engineers and Soil Scientists
Agri-Waste Technology, Inc.
501 N. Salem Street, Suite 203
Apex, North Carolina 27502
919-859-0669
www.agriwaste.com

Whittaker Property
Repair HWTS

Owner Information:
Robert Whittaker
88 Brookview Court
Angier, NC 27501
(401) 710-2054
rwhittaker1@verizon.net

Property Information:
88 Brookview Court
Lot 4 - The Creek
Angier, NC 27501
Harnett County
PIN: 0672-60-2085.000

This document originally
issued and sealed by
Scott P. Jones,
N.C. PE #045605,
on November 18, 2020.
This medium shall not be
considered a certified
document.

FINAL DESIGN
NOT RELEASED FOR CONSTRUCTION

REV.	ISSUED DATE	DESCRIPTION

SHEET TITLE

Property Layout

DRAWN BY: S. Jones	CREATED ON: 10/30/2020
REVISED BY:	REVISED ON:
RELEASED BY:	RELEASED ON:

SHEET NAME:
WW-2

16/1/20

NOTES:

- 1.) Remove existing D-Box and Step Downs.
- 2.) Contractor shall re-establish vegetation over all disturbed areas.
- 3.) Damaged chambers shall be replaced.
- 4.) Leak Test required for existing tanks,
- 5.) Control Panel shall have elapsed timer and counter.

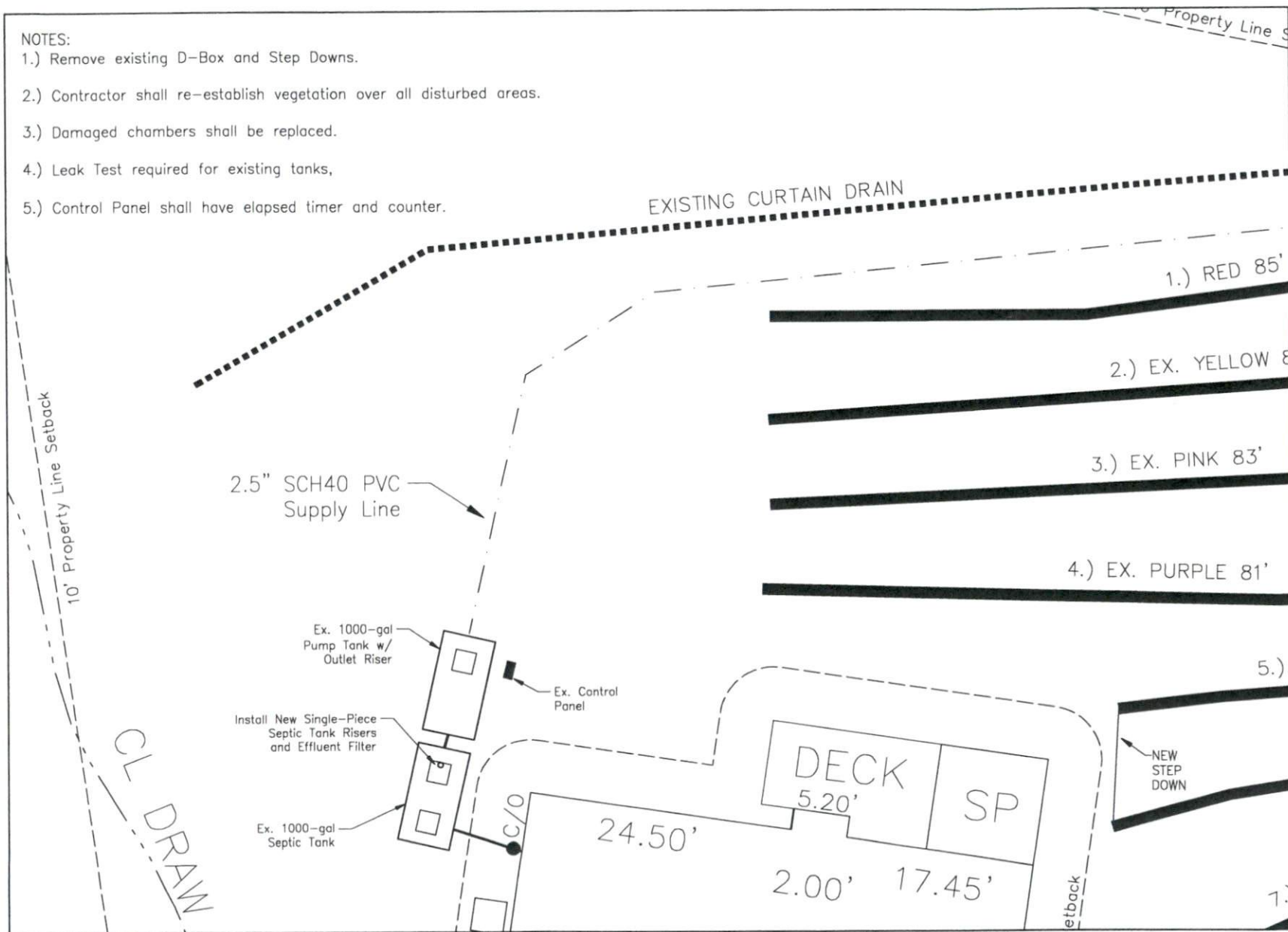

Agri-Waste Technology, Inc.
501 N. Salem Street, Suite 203
Apex, North Carolina 27502
919-859-0669
www.agriwaste.com

Whittaker Property
Repair WWTS

Owner Information:
Robert Whittaker
88 Brookvies Court
Angier, NC 27501
(401) 710-2054
rwhittaker@verizon.net

Property Information:
88 Brookvies Court
Lot 4 - The Creek
Angier, NC 27501
Harnett County
PIN: 0572-60-2085.000

This document originally issued and sealed by Scott P. Jones, N.C. PE #045605, on November 18, 2020. This medium shall not be considered a certified document.

FINAL DESIGN
NOT RELEASED FOR CONSTRUCTION

REV. ISSUED DATE DESCRIPTION

REV.	ISSUED DATE	DESCRIPTION

SHEET TITLE

Component Layout

DRAWN BY: S. Jones	CREATED ON: 10/30/2020
REVISED BY:	REVISED ON:
RELEASED BY:	RELEASED ON:

SHEET NAME:

WW-3

COMPONENT LAYOUT

Scaled for 24"x36" output

17/11

Whittaker Property
 Repair WWTS

Owner Information:
 Robert Whittaker
 88 Brookley Court
 Angier, NC 27501
 (401) 715-7094
 rwhittaker1@verizon.net

Property Information:
 88 Brookley Court
 Lot 4 - The Creeks
 Angier, NC 27501
 Harnett County
 PIN: 0672-60-2085.000

This document originally
 issued and sealed by
 Scott P. Jones,
 N.C. PE #045605,
 on November 18, 2020.
 This medium shall not be
 considered a certified
 document.

FINAL DESIGN
 NOT RELEASED FOR CONSTRUCTION

REV. ISSUED DATE DESCRIPTION

SHEET TITLE

Repair
 Drainfield

DRAWN BY: S. Jones
 CREATED ON: 10/30/2020

REVISED BY: REVISED ON:

RELEASED BY: RELEASED ON:

SHEET NAME:

WW-4

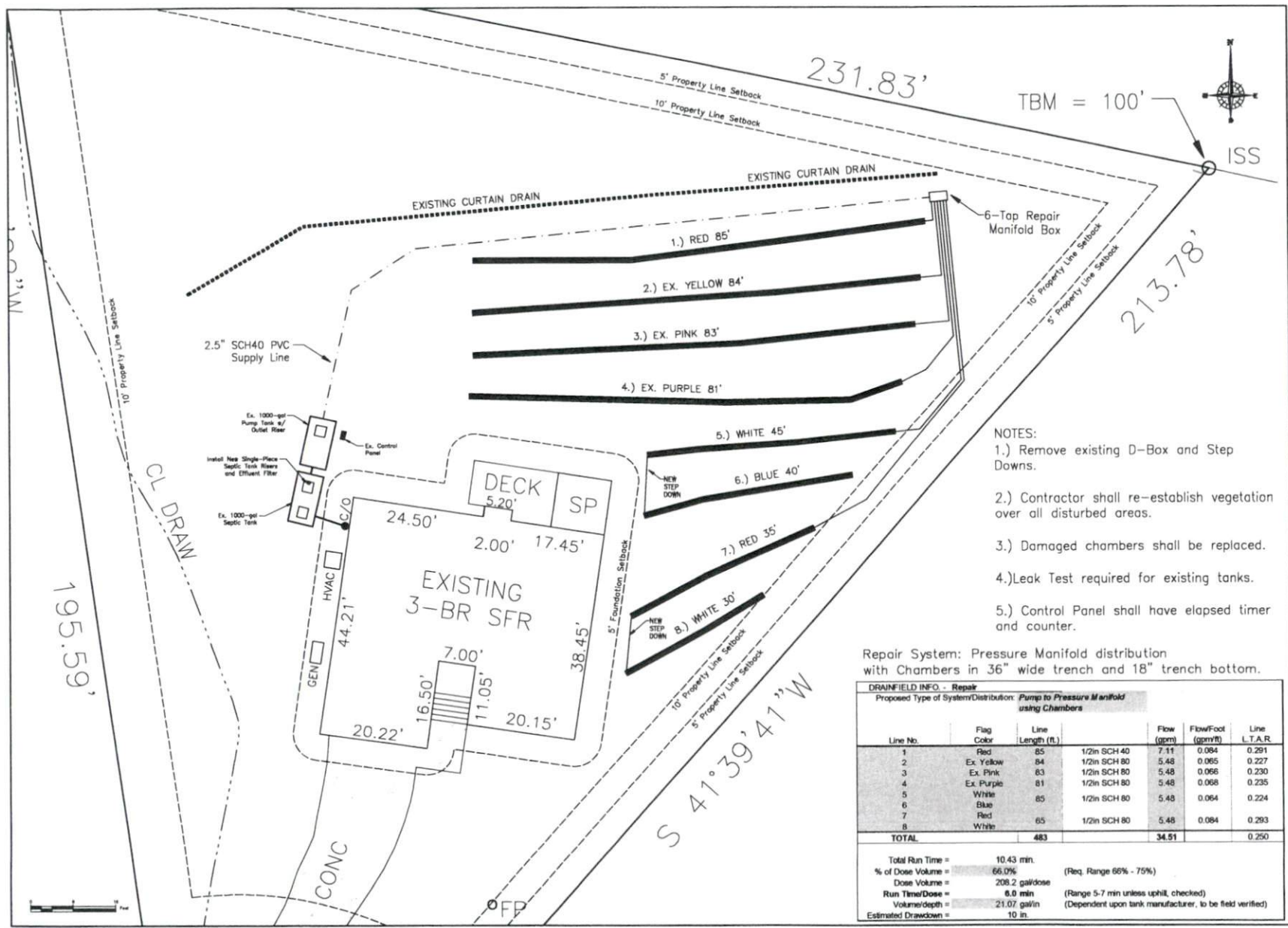

- NOTES:
- 1.) Remove existing D-Box and Step Downs.
 - 2.) Contractor shall re-establish vegetation over all disturbed areas.
 - 3.) Damaged chambers shall be replaced.
 - 4.) Leak Test required for existing tanks.
 - 5.) Control Panel shall have elapsed timer and counter.

Repair System: Pressure Manifold distribution with Chambers in 36" wide trench and 18" trench bottom.

DRAINFIELD INFO - Repair
 Proposed Type of System/Distribution: Pump to Pressure Manifold using Chambers

Line No.	Flag Color	Line Length (ft.)	1/2in SCH 40	Flow (gpm)	Flow/Foot (gpm/ft)	Line L.T.A.R.
1	Red	85	1/2in SCH 40	7.11	0.084	0.291
2	Ex. Yellow	84	1/2in SCH 80	5.48	0.065	0.227
3	Ex. Pink	83	1/2in SCH 80	5.48	0.066	0.230
4	Ex. Purple	81	1/2in SCH 80	5.48	0.068	0.235
5	White	45	1/2in SCH 80	5.48	0.064	0.224
6	Blue	40	1/2in SCH 80	5.48	0.064	0.224
7	Red	35	1/2in SCH 80	5.48	0.064	0.293
8	White	30	1/2in SCH 80	5.48	0.064	0.293
TOTAL		483		34.51		0.250

Total Run Time = 10.43 min.
 % of Dose Volume = 66.0% (Req. Range 66% - 75%)
 Dose Volume = 208.2 gal/dose
 Run Time/Dose = 8.0 min (Range 5-7 min unless uphill, checked)
 Volume/depth = 21.07 gal/in (Dependent upon tank manufacturer, to be field verified)
 Estimated Drawdown = 10 in.

REPAIR DRIPFIELD LAYOUT

Scaled for 24"X36" output

18/81

Whittaker Property
 Repair WWTs

Owner Information:
 Robert Whittaker
 88 Brookline Court
 Angier, NC 27501
 (401) 710-2054
 rwhittaker@verizon.net

Property Information:
 88 Brookline Court
 Lot 4 - The Creek
 Angier, NC 27501
 Harnett County
 PH: 0672-80-2095.000

This document originally
 issued and sealed by
 Scott P. Jones,
 N.C. PE #045605,
 on November 18, 2020.
 This medium shall not be
 considered a certified
 document.

FINAL DESIGN
 NOT RELEASED FOR CONSTRUCTION

REV. ISSUED DATE DESCRIPTION

SHEET TITLE

Detail Sheet 1

DRAWN BY: S. Jones
 CREATED ON: 10/30/2020

REVISED BY: REVISED ON:

RELEASED BY: RELEASED ON:

SHEET NAME:

WW-5

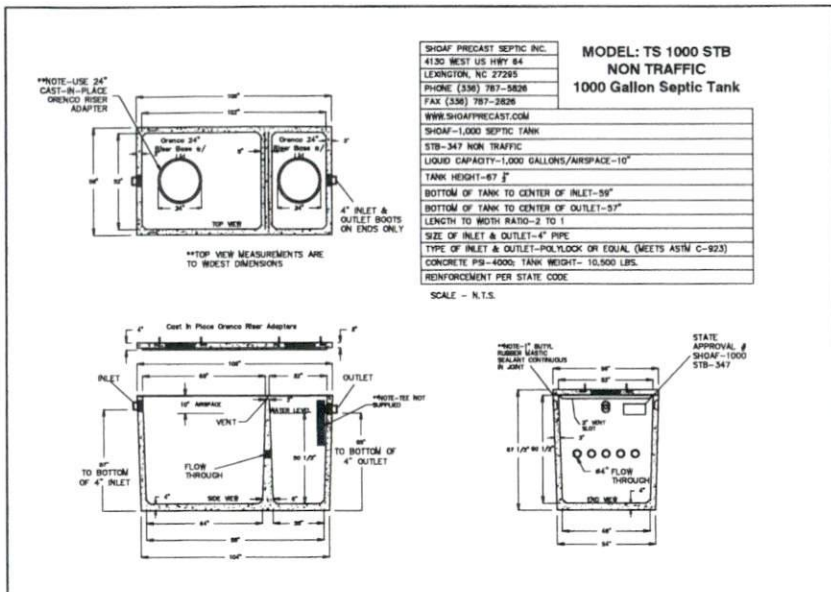

SEPTIC TANK DETAIL (or equivalent if tank is replaced)

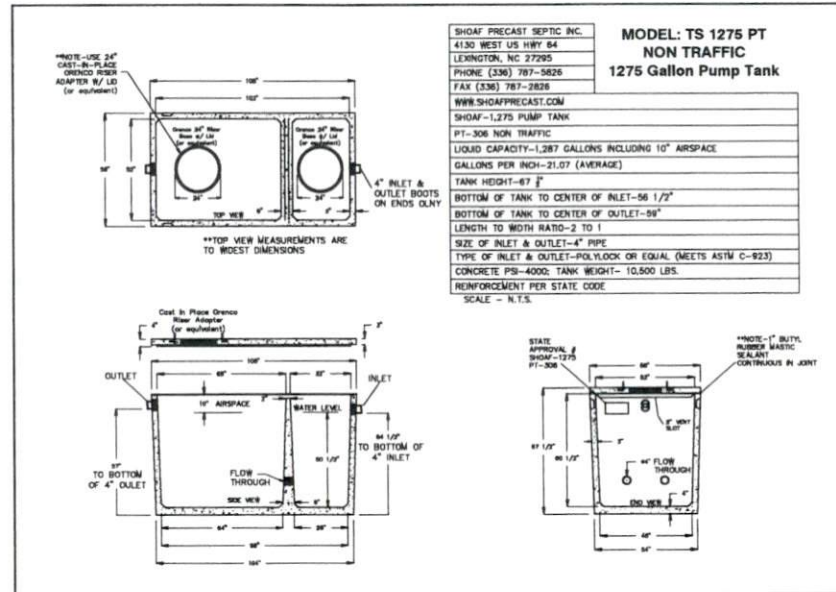

PUMP TANK DETAIL (or equivalent tank with 1-day storage if tank is replaced)

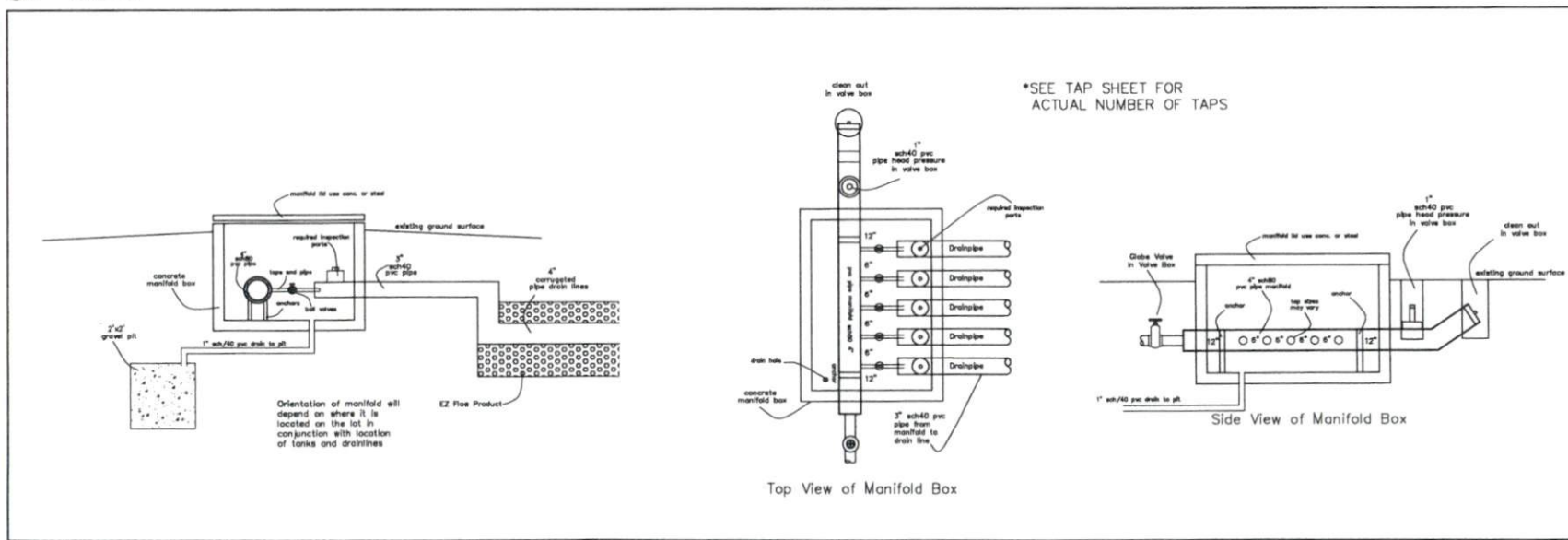

Manifold Detail - FOR ILLUSTRATION ONLY

1/1/20

Trimming and Excavation Safety

The engineer must comply with the following and excavation requirements of 29 CFR 1926.651 and 1926.652 or the applicable OSHA-approved state law requirements.

Excavation Requirements

OSHA standards require that a competent person inspect trenches daily and an authorized change before workers return to excavation. A competent person is one who is trained, experienced, or knowledgeable in the excavation work and is authorized to take prompt corrective action to eliminate these hazards and conditions.

Access and Egress

OSHA standards require safe access and egress to and from excavations, including ladders, stairs, ramps, or other means of access. The maximum height of any trench, excavation, or shaft shall not exceed 20 feet (6.1 meters) or the maximum height of the trench, excavation, or shaft shall be limited when 20 feet (6.1 meters) or less.

Definitions

"Competent person" means a person who has had the training and experience to identify and evaluate the hazards of excavation work, and who is authorized to take prompt corrective action to eliminate these hazards and conditions.

"Excavation" means a hole, cut, trench, or similar opening in the earth, the sides of which are exposed, and which is deeper than it is wide, and which is not a trench, shaft, or well.

"Shoring" means a structure used to support or brace an excavation, trench, or similar opening in the earth.

"Scaffolding" means a structure used to support or brace an excavation, trench, or similar opening in the earth.

"Undermining" means the removal of soil or rock from beneath an existing structure, which may result in the structure's collapse.

"Vertical excavation" means an excavation, trench, or similar opening in the earth, the sides of which are exposed, and which is deeper than it is wide, and which is not a trench, shaft, or well.

Soil Classification System

For the purpose of this subpart, a method of categorizing soil and rock conditions is determined based on an analysis of the properties and performance characteristics of the soil and rock. The classification system is based on the following criteria:

- (1) The soil's ability to support a load without excessive settlement.
- (2) The soil's ability to resist lateral movement.
- (3) The soil's ability to resist sliding.
- (4) The soil's ability to resist overturning.
- (5) The soil's ability to resist crushing.
- (6) The soil's ability to resist erosion.
- (7) The soil's ability to resist weathering.
- (8) The soil's ability to resist chemical degradation.
- (9) The soil's ability to resist biological degradation.
- (10) The soil's ability to resist physical degradation.

Soil Types

- (1) **Type A** - Soils with an unconfined compressive strength greater than 1.5 tons per square foot (114 kPa) and a cohesion value of at least 0.5 tons per square foot (35 kPa).
- (2) **Type B** - Soils with an unconfined compressive strength greater than 1.5 tons per square foot (114 kPa) and a cohesion value of at least 0.25 tons per square foot (17.5 kPa).
- (3) **Type C** - Soils with an unconfined compressive strength greater than 1.5 tons per square foot (114 kPa) and a cohesion value of at least 0.1 tons per square foot (7 kPa).
- (4) **Stable Rock** - Soil that meets the unconfined compressive strength or cohesion requirements for Type A, but is not a soil.
- (5) **Other Soil** - Soil that does not meet the requirements for Type A, B, or C.

Excavations in Type A Soils

All simple slope excavations 20 feet or less in depth shall have a maximum allowable slope of 3/4:1.



Excavation: Simple slope excavations which are deeper than 20 feet or less in depth shall have a maximum allowable slope of 3/4:1.



Excavation: Stepped excavations 20 feet or less in depth shall have a maximum allowable slope of 3/4:1.



Excavation: Vertical excavations 20 feet or less in depth shall have a maximum allowable slope of 3/4:1.



Excavation: Vertical excavations 20 feet or less in depth shall have a maximum allowable slope of 3/4:1.



Excavation: Vertical excavations 20 feet or less in depth shall have a maximum allowable slope of 3/4:1.

Excavations in Type B Soils

All simple slope excavations 20 feet or less in depth shall have a maximum allowable slope of 1:1.



Excavation: Simple slope excavations 20 feet or less in depth shall have a maximum allowable slope of 1:1.



Excavation: Stepped excavations 20 feet or less in depth shall have a maximum allowable slope of 1:1.



Excavation: Vertical excavations 20 feet or less in depth shall have a maximum allowable slope of 1:1.



Excavation: Vertical excavations 20 feet or less in depth shall have a maximum allowable slope of 1:1.



Excavation: Vertical excavations 20 feet or less in depth shall have a maximum allowable slope of 1:1.

Excavations in Type C Soils

All simple slope excavations 20 feet or less in depth shall have a maximum allowable slope of 1 1/2:1.



Excavation: Simple slope excavations 20 feet or less in depth shall have a maximum allowable slope of 1 1/2:1.



Excavation: Stepped excavations 20 feet or less in depth shall have a maximum allowable slope of 1 1/2:1.



Excavation: Vertical excavations 20 feet or less in depth shall have a maximum allowable slope of 1 1/2:1.



Excavation: Vertical excavations 20 feet or less in depth shall have a maximum allowable slope of 1 1/2:1.



Excavation: Vertical excavations 20 feet or less in depth shall have a maximum allowable slope of 1 1/2:1.

Excavations in Layered Soils

All excavations 20 feet or less in depth made in layered soils shall have a maximum allowable slope for each layer as set forth below.

Excavation: Layered excavations 20 feet or less in depth shall have a maximum allowable slope for each layer as set forth below.

Excavation: Layered excavations 20 feet or less in depth shall have a maximum allowable slope for each layer as set forth below.

Excavation: Layered excavations 20 feet or less in depth shall have a maximum allowable slope for each layer as set forth below.

Excavation: Layered excavations 20 feet or less in depth shall have a maximum allowable slope for each layer as set forth below.

Excavation: Layered excavations 20 feet or less in depth shall have a maximum allowable slope for each layer as set forth below.

Requirements

(1) Construction of soil and rock slopes. Each soil and rock slope shall be classified by a competent person as to its stability. The classification of the slope shall be based on the analysis of the soil and rock conditions and the characteristics of the slope and the environmental conditions of the slope.

- (2) The soil and rock slope shall be classified as to its stability.
- (3) The soil and rock slope shall be classified as to its stability.
- (4) The soil and rock slope shall be classified as to its stability.
- (5) The soil and rock slope shall be classified as to its stability.
- (6) The soil and rock slope shall be classified as to its stability.
- (7) The soil and rock slope shall be classified as to its stability.
- (8) The soil and rock slope shall be classified as to its stability.
- (9) The soil and rock slope shall be classified as to its stability.
- (10) The soil and rock slope shall be classified as to its stability.

Acceptable Visual and Manual Tests

- (1) Visual tests. Visual analysis is conducted to determine qualitative information regarding the excavation site in general. The soil adjacent to the excavation, the soil forming the sides of the open excavation, and the soil within the excavation shall be visually inspected.
- (2) Changes in soil conditions. Changes in soil conditions shall be visually inspected. Changes in soil conditions shall be visually inspected.
- (3) Changes in soil conditions. Changes in soil conditions shall be visually inspected. Changes in soil conditions shall be visually inspected.
- (4) Changes in soil conditions. Changes in soil conditions shall be visually inspected. Changes in soil conditions shall be visually inspected.
- (5) Changes in soil conditions. Changes in soil conditions shall be visually inspected. Changes in soil conditions shall be visually inspected.
- (6) Changes in soil conditions. Changes in soil conditions shall be visually inspected. Changes in soil conditions shall be visually inspected.
- (7) Changes in soil conditions. Changes in soil conditions shall be visually inspected. Changes in soil conditions shall be visually inspected.
- (8) Changes in soil conditions. Changes in soil conditions shall be visually inspected. Changes in soil conditions shall be visually inspected.
- (9) Changes in soil conditions. Changes in soil conditions shall be visually inspected. Changes in soil conditions shall be visually inspected.
- (10) Changes in soil conditions. Changes in soil conditions shall be visually inspected. Changes in soil conditions shall be visually inspected.

Professional Engineer Seal

Professional Engineer Seal

Whitaker Property Repair WRTS

Whitaker Property Repair WRTS

Excavation Safety

Excavation Safety

Excavation Safety

Excavation Safety

Excavation Safety

Excavation Safety

Excavation Safety

Excavation Safety

Excavation Safety

Excavation Safety

Excavation Safety

Excavation Safety

Excavation Safety

Excavation Safety

Excavation Safety

Excavation Safety

Excavation Safety

Excavation Safety

Excavation Safety

Excavation Safety

Excavation Safety

Excavation Safety

Excavation Safety

Excavation Safety

Excavation Safety

Excavation Safety

Excavation Safety

Excavation Safety

Excavation Safety

Excavation Safety

Excavation Safety

Excavation Safety

Excavation Safety

Excavation Safety

Excavation Safety

Excavation Safety

Excavation Safety

Excavation Safety

Excavation Safety

Excavation Safety

Excavation Safety

Excavation Safety

Excavation Safety

Excavation Safety

Excavation Safety

Excavation Safety

Excavation Safety

Excavation Safety

Excavation Safety

Excavation Safety

Excavation Safety

Excavation Safety

Excavation Safety

Excavation Safety

Excavation Safety

Excavation Safety

Excavation Safety

Excavation Safety

Excavation Safety

Excavation Safety

Excavation Safety

Excavation Safety

Excavation Safety

Excavation Safety

Excavation Safety

Excavation Safety

Excavation Safety

Excavation Safety

Excavation Safety

Excavation Safety

Excavation Safety

Excavation Safety

Excavation Safety

Excavation Safety

Excavation Safety

Excavation Safety

Excavation Safety

Excavation Safety

Excavation Safety

Excavation Safety

Excavation Safety

Excavation Safety

Excavation Safety

Excavation Safety

Excavation Safety

Excavation Safety

Excavation Safety

Excavation Safety

Excavation Safety

Excavation Safety

Excavation Safety

Excavation Safety

Excavation Safety

Excavation Safety

Excavation Safety

Excavation Safety

Excavation Safety

Excavation Safety

Excavation Safety

Excavation Safety

Excavation Safety

Excavation Safety

Excavation Safety

Excavation Safety

Excavation Safety

Excavation Safety

Excavation Safety

Excavation Safety

Excavation Safety

Excavation Safety

Excavation Safety

Excavation Safety

Excavation Safety

Excavation Safety

Excavation Safety

Excavation Safety

Excavation Safety

Excavation Safety

Excavation Safety

Excavation Safety

Excavation Safety

Excavation Safety

Excavation Safety

Excavation Safety

Excavation Safety

Excavation Safety

Excavation Safety

Excavation Safety

Excavation Safety

Excavation Safety

Excavation Safety

Excavation Safety

Excavation Safety

Excavation Safety

Excavation Safety

Excavation Safety

Excavation Safety

Excavation Safety

Excavation Safety

Excavation Safety

Excavation Safety

Excavation Safety

Excavation Safety

Excavation Safety

IF TANK IS REPLACED

**NOTE-USE 24" CAST-IN-PLACE ORENCO RISER ADAPTER

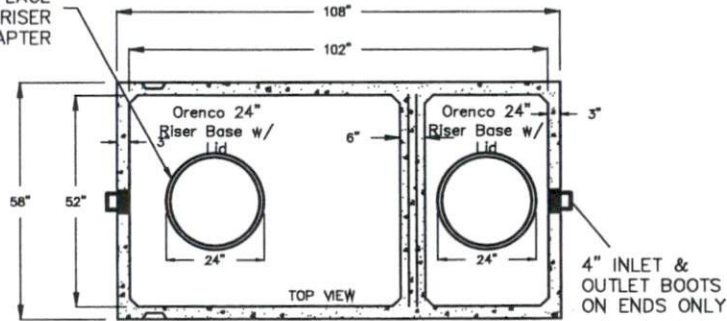

**TOP VIEW MEASUREMENTS ARE TO WIDEST DIMENSIONS

SHOAF PRECAST SEPTIC INC.
 4130 WEST US HWY 64
 LEXINGTON, NC 27295
 PHONE (336) 787-5826
 FAX (336) 787-2826

**MODEL: TS 1000 STB
 NON TRAFFIC
 1000 Gallon Septic Tank**

WWW.SHOAPRECAST.COM
SHOAF-1,000 SEPTIC TANK
STB-347 NON TRAFFIC
LIQUID CAPACITY-1,000 GALLONS/AIRSPACE-10"
TANK HEIGHT-67 1/2"
BOTTOM OF TANK TO CENTER OF INLET-59"
BOTTOM OF TANK TO CENTER OF OUTLET-57"
LENGTH TO WIDTH RATIO-2 TO 1
SIZE OF INLET & OUTLET-4" PIPE
TYPE OF INLET & OUTLET-POLYLOCK OR EQUAL (MEETS ASTM C-923)
CONCRETE PSI-4000; TANK WEIGHT- 10,500 LBS.
REINFORCEMENT PER STATE CODE

SCALE - N.T.S.

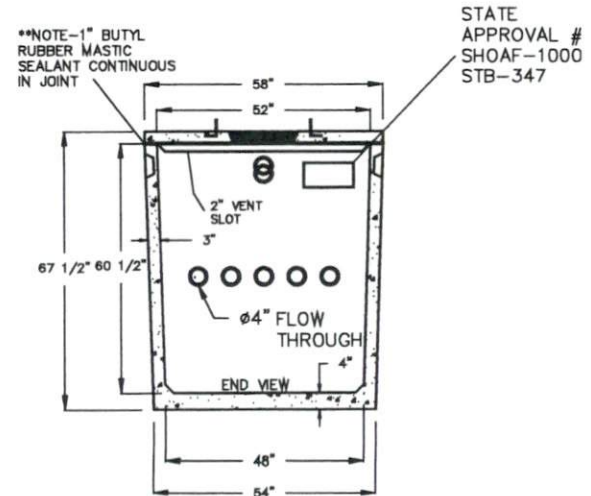
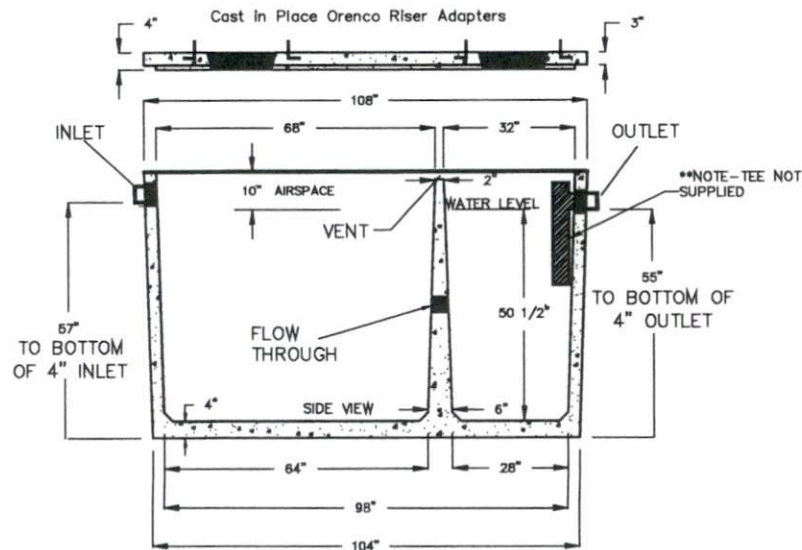

22/42

IF TANK IS REPLACED

**NOTE--USE 24" CAST-IN-PLACE ORENCO RISER ADAPTER W/ LID (or equivalent)

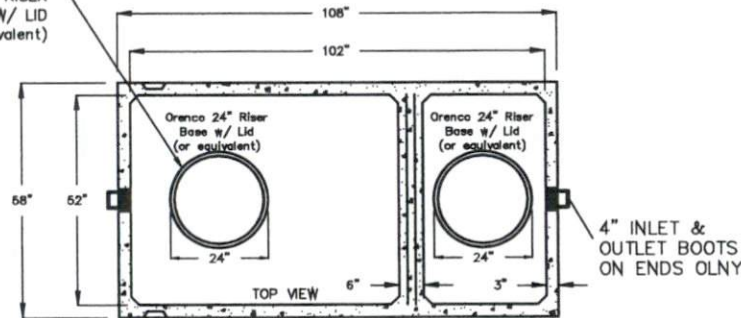

**TOP VIEW MEASUREMENTS ARE TO WIDEST DIMENSIONS

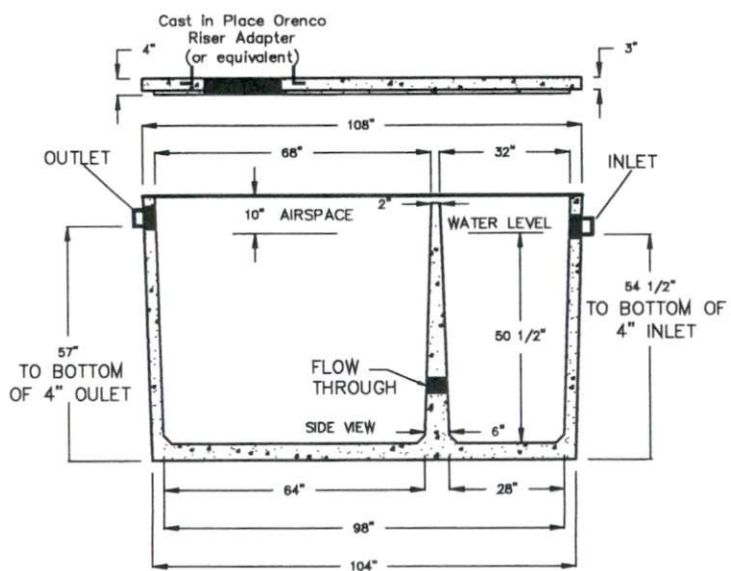

SHOAF PRECAST SEPTIC INC.
4130 WEST US HWY 64
LEXINGTON, NC 27295
PHONE (336) 787-5826
FAX (336) 787-2826

**MODEL: TS 1275 PT
NON TRAFFIC
1275 Gallon Pump Tank**

WWW.SHOAFPRECAST.COM
SHOAF-1,275 PUMP TANK
PT-306 NON TRAFFIC
LIQUID CAPACITY-1,287 GALLONS INCLUDING 10" AIRSPACE
GALLONS PER INCH-21.07 (AVERAGE)
TANK HEIGHT-67 1/2"
BOTTOM OF TANK TO CENTER OF INLET-56 1/2"
BOTTOM OF TANK TO CENTER OF OUTLET-59"
LENGTH TO WIDTH RATIO-2 TO 1
SIZE OF INLET & OUTLET-4" PIPE
TYPE OF INLET & OUTLET-POLYLOCK OR EQUAL (MEETS ASTM C-923)
CONCRETE PSI-4000; TANK WEIGHT- 10,500 LBS.
REINFORCEMENT PER STATE CODE

SCALE - N.T.S.

STATE APPROVAL # SHOAF-1275 PT-306

**NOTE-1" BUTYL RUBBER MASTIC SEALANT CONTINUOUS IN JOINT

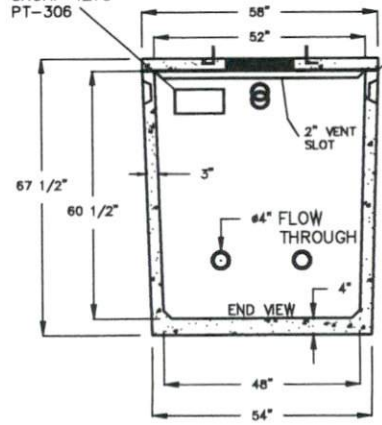

23/17

4" Biotube[®] Effluent Filter



Oreco Systems
Incorporated
1-800-348-9843

Installation and Maintenance Instructions

Biotube Effluent Filters* extend drainfield life by preventing solids from leaving the septic tank. Our 4" filter comes in its own housing, in both 36" and 28" lengths. Our 18" Jr. insert filter comes with or without its own housing. Biotube Effluent Filters install in minutes, inside new or existing tanks.



Step 1: Test-Fit the Effluent Filter

Test-fit the effluent filter on the septic tank's outlet pipe without gluing. Make sure it fits plumb. Install assembly as snug as possible to the tank wall, but ensure sufficient clearance for removing filter cartridge.

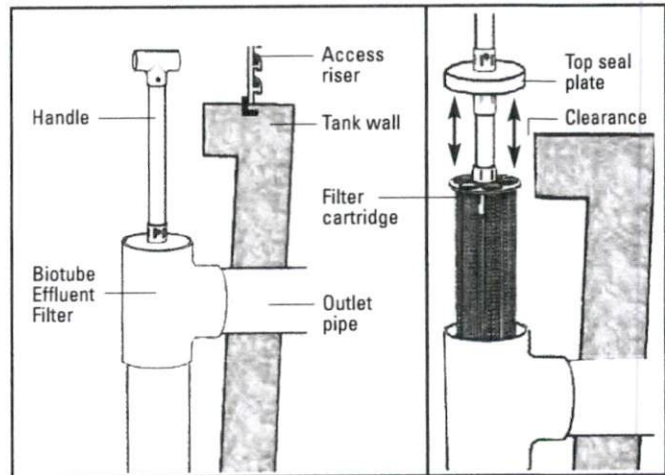

The Biotube Effluent Filter, with its housing, is suspended in the septic tank, supported by the 4" outlet pipe.

24/42

Installation Instructions (continued)

Step 2: Attaching Filter to Tank

Two attachment methods can be used:

- 1) Glue the filter onto the tank outlet pipe using appropriate primer and glue.
- 2) A stainless steel set screw can be used to secure the filter instead of glue.

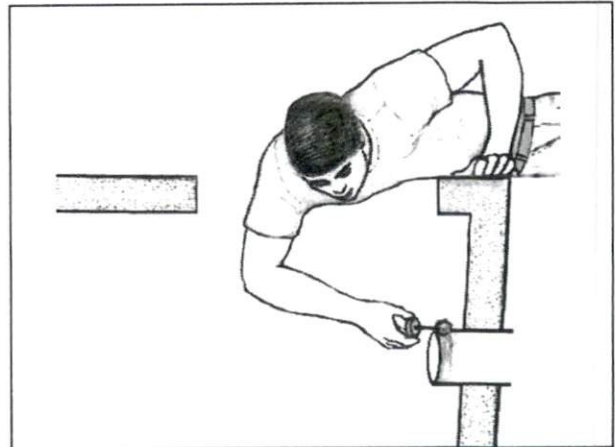

This illustration shows the gluing technique for installing a filter into a new septic tank. Installing a filter into an existing tank is a custom, site-specific job.

Step 3: Extending Cartridge Handle

For easier access when servicing, the cartridge handle may be extended using a longer length of 3/4" schedule 40 PVC pipe.

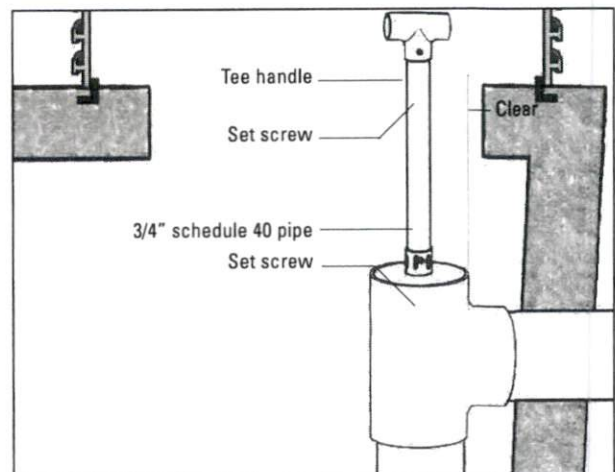

Cartridge handles can be extended for easier access.

PRTA ABS Tank Adapters

Applications

PRTA tank adapters are used to provide a structural, water-tight method of installing a 24-in. (610 mm) or a 30-in. (762 mm) access riser over a tank opening.

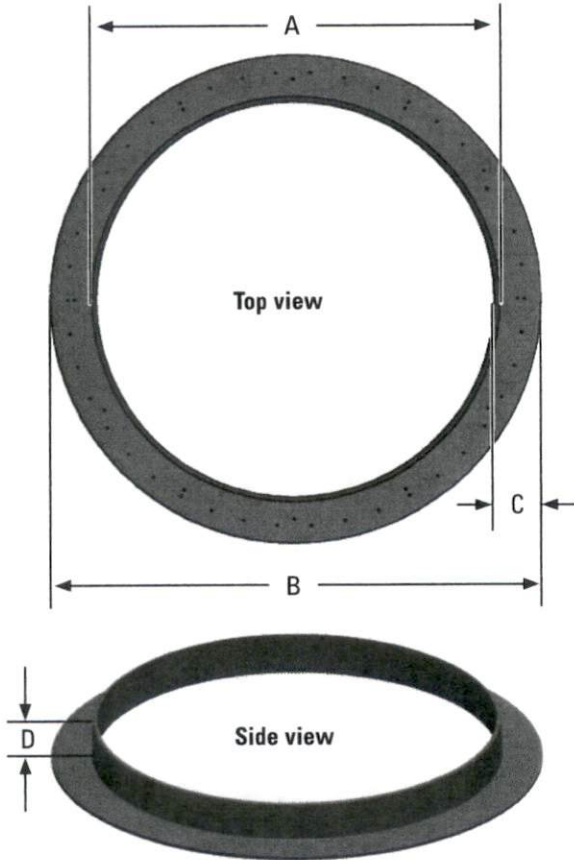

General

Orengo's PRTA tank adapters are molded plastic products and therefore have excellent part-quality and consistency. PRTA tank adapters can be cast into a tank or fastened to the top of the tank with a bolt-down kit. The bolt-down kit consists of either six or twelve (depending on model) stainless steel concrete anchors and a roll of butyl tape.

The O.D. of the vertical flange matches the I.D. of Orengo's ribbed risers, which provides a suitable joint to seal with MA320, ADH100, SS115, or SS140 adhesive.

Standard Models

PRTA24	Cast in Place Tank Adapters
PRTA30	for any New Tank
PRTA24BDKIT (6 anchors)	One for each end of Septic Tank and one for Pump Tank
PRTA30BDKIT (12 anchors)	3 x PRTA24

Nomenclature

PRTA	<input type="checkbox"/>	Riser diameter
	24	= 24" riser (Perma-Loc, Ultra-Rib, KOR FLO)
	30	= 30" riser (Perma-Loc, Ultra-Rib)
		ABS riser tank adapter

Materials of Construction

Tank adapter	ABS
Concrete anchors	Stainless steel anchor bolts
Sealant	Butyl tape

Specifications

Dimensions*	PRTA24	PRTA30
A - Outside diameter	23.38 in. (594 mm)	29.25 in. (743 mm)
B - Flange diameter	26.75 in. (679 mm)	34.25 in. (870 mm)
C - Horizontal flange width	2.00 in. (51 mm)	2.50 in. (64 mm)
D - Vertical flange height	3.50 in. (89 mm)	3.25 in. (83 mm)

*The tank adapter has a nominal 0.25 inch (6 mm) thickness.

26/12

Access Risers – Ultra-Rib™

Applications

Oreco's Access Risers provide access to septic tank openings and can be cast into the tops of concrete tanks, bonded in place, or bolted down using a riser tank adaptor. They can also be used as valve enclosures.

General

Oreco Ultra-Rib™ Access Risers are constructed of ribbed PVC pipe and are available in 12-, 18-, 21-, and 24-in. diameters. They can be ordered in 3-in. (76.2-mm) increments in lengths up to 13 ft (3.96 m) for 12- and 18-in. diameter risers, and up to 14 ft (4.27 m) for 21- and 24-in. diameter risers. Oreco Ultra-Rib riser pipe is also available in truckload quantities. A complete line of Oreco pipe-cutting tools makes it easy to fabricate risers in your shop or in the field

Standard Models

RR12XX, RU18XX, RR21XX, RR24XX

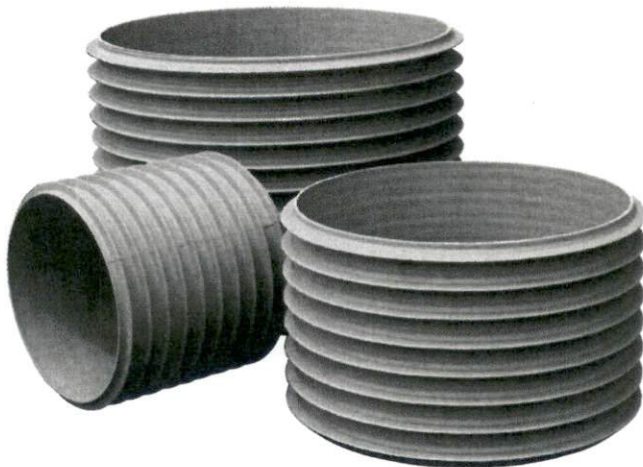

Nomenclatures

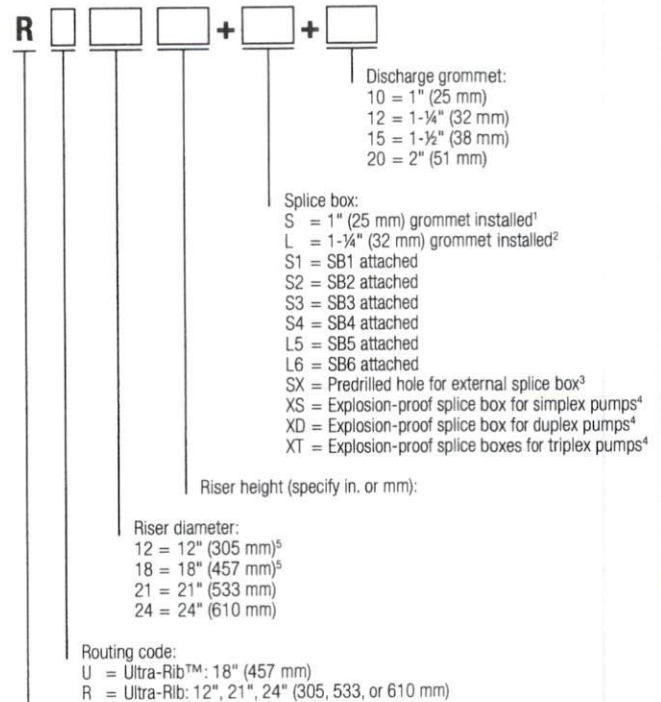

Riser

- ¹ For Oreco SB1 - SB4 splice boxes
- ² For Oreco SB5, SB6 splice boxes
- ³ Minimum riser height 18" (457 mm)
- ⁴ Used in Class I Division I environments
- ⁵ Not intended for use over pump vaults

RPU

Indicates riser diameter:
12 = 12" (300 mm)¹
18 = 18" (450 mm)¹
21 = 21" (525 mm)²
24 = 24" (600 mm)²

Bulk Ultra-Rib™ riser pipe

¹ 13' (3.96 m) length
² 14' (4.27 m) length

Materials of Construction

Ultra-Rib™ PVC Pipe: PVC

Specifications

Model	RR12XX	RU18XX	RR21XX	RR24XX
I.D., in. (mm)	11.74 (298)	17.65 (448)	20.50 (521)	23.50 (597)
Wall Thickness - excluding ribs, in. (mm)	0.10 (3)	0.19 (5)	0.25 (6)	0.25 (6)
O.D. - including ribs, in. (mm)	13.13 (334)	19.44 (494)	22.63 (575)	25.63 (651)
Weight, lbs per ft (kg per m)	5 (7.4)	11 (16.4)	15 (22.3)	19 (28.3)

27/42

Access Risers and Tank Adapters

Installation Instructions

Access risers provide access to septic tank openings, simplifying inspection and maintenance procedures. It is important that the riser be sized correctly and installed properly (i.e., appropriate tank adapter, attachment method, etc.) to ensure a watertight seal. Without a watertight seal, groundwater or surface water can leak into the tank, reducing the tank's performance. When setting a riser, orient the grommets in the appropriate directions before bonding to the tank.

In this document, metric equivalents are omitted for nominal dimensions, such as riser and pipe diameters. If you are using pipe other than IPS standard sizes, consult your Distributor for adapters you may need.

Riser Sizing

The installed riser should extend about 3 in. (76 mm) above the finished ground level (approximately 2 in. [51 mm] for tank settlement and 1 in. [25 mm] to ensure drainage away from the riser). If the riser is too long, it may be cut to the appropriate height using a circular saw or table saw. Always cut excess length from the bottom of the riser. To ensure a good fit and watertight joint, a square cut is essential. If the riser is too short, a grade ring may be used as an extension.

Selecting a Riser and Tank Adapter Installation Method

To select an appropriate riser and tank adapter installation method, first determine the type of tank being used: concrete or fiberglass. Then refer to the chart below, as you follow these steps:

Concrete Tanks

1. Determine desired riser diameter.
2. Determine if the riser tank adapter will be cast-in or bolted down.
3. Referring to the chart below, pick the appropriate tank adapter for your riser diameter and method of attachment.
If the bolt-down method is being used, make sure the adapter you selected will cover the tank's opening.

Oreco Fiberglass Tanks (contact your distributor or Oreco for other fiberglass tanks)

1. For 30-in. riser, choose the FRTA30-FRP tank adapter.
2. For 24-in. riser, no adapter is needed; 24-in. riser fits tank directly.

Riser diameter	Method of attachment	Tank adapter	Maximum tank opening	
24 in.	Bolted down or cast into concrete tank	PRTA24	24 in. round/17 in. square*	* NOTE: For PRTA 24 and PRTA 30 risers, the minimum tank opening is 19 in., but 20 in. is recommended, so that the Biotube Pump Vault (PVU) can rest on the lip of the opening.
30 in.	Bolted down or cast into concrete tank	PRTA30	30 in. round/21 in. square*	
21 or 24 in.	Bolted down to concrete tank or epoxied to top of non-Oreco FRP tank	RRFTA	24 in. round/24 in. square	
30 in.	Bolted down to concrete tank	RRFTA30	30 in. round/30 in. square	
30 in.	Glued onto Oreco FRP tank or PRTA24, allowing it to accept 30-in. riser.	FRTA30-FRP	NA	
12 in.	Bolted down to concrete tank	RUBDKIT	10 in. round/7 in. square	
18 in.	Bolted down to concrete tank	RUBDKIT	16 in. round/11 in. square	

Choosing Your Instruction Set

Following are five different installation instruction sets for adapters, depending on your application, adapter, and method of attachment. Refer to the chart below to determine which instruction set to use. Instructions for installing grommets in risers are also provided.

Instruction set	Adapter type used	Page
1. Oreco FRP Tank Adapter	FRTA30-FRP	3
2. Cast-In Adapters	PRTA24, PRTA30	4
3. Round Bolt-Down Adapters	PRTA24, PRTA30	5
4. Square Bolt-Down Adapters	RRFTA, RRFTA30	6
5. No Adapters: Ultra-Rib Bolt-Down Kit	None, Ultra-Rib pipe	7
Installing Grommets in Risers		8

Installation Instructions (continued)



Clockwise from left: ADH10 (IPS810) quart, SS115, ADH100, SS140, ADH845, ADH10 (IPS810) pint, and MA320

Use ADH 100 or MA 320

About Adhesives

ADH100 is a single-component adhesive/sealant for sealing pipe grommets and joining PVC or fiberglass risers to ABS or fiberglass PRTA-style tank adapters (where the joint is in shear). Handling strength is achieved within 12 hours, and full cure in 2 to 3 days. It comes in a 10.2-oz (300-mL) cartridge tube for application with a caulking gun.

ADH10 (IPS810) adhesive is a white, two-component, self-leveling methacrylate adhesive for bonding PVC, ABS, fiberglass, and concrete. ADH10 comes in pint (500-mL) and quart (1000-mL) kits, consisting of A and B components (adhesive and activator), and requires hand mixing. If a self-leveling adhesive is NOT required or if concrete is NOT being bonded, SS115 or SS140 is preferred over ADH10.

ADH845 adhesive is a tan two-component methacrylate adhesive for bonding PVC, ABS, fiberglass, and concrete. This is our only adhesive formulated to work in wet conditions or even under water, making it ideal for field repairs. Repairs on leaking riser connections are possible, but any water pressure must be removed during the repair. ADH845 has the consistency of molasses, comes in 400-mL cartridges, and requires the manual dispensing gun ADH845-GUN.

MA320 is a white two-component methacrylate adhesive that bonds PVC, ABS and fiberglass to themselves or each other, but does not bond to concrete. It comes in a two-part 200-gram see-through plastic pouch that must be kneaded to mix the two components, then cut open and squeezed to apply adhesive.

SS140 adhesive is a gray two-component methacrylate adhesive for bonding PVC and fiberglass to themselves or each other. It does not bond to concrete. It has the consistency of toothpaste and will sag slightly in warmer temperatures. Surface roughening is recommended and provides the best bond strengths, but is not always necessary. Use SS140 above 65° F (18° C) and SS115 below 50° F (10° C). Working life of mixed adhesive is typically 20 to 30 minutes, and it usually hardens in less than 2 hours, depending on temperature and adhesive thickness. It comes in an 870-mL two-part cartridge and can be dispensed from pneumatic gun SS-MK or, for occasional use, manual gun SS-MK-MANUAL GUN.

SS115 adhesive is a white two-component methacrylate adhesive with properties similar to those of SS140 and comes in the same two-part cartridge, but has a much shorter open time for use in cooler temperatures and jobs where quicker cure times are desired, or for applications where a white color is desired. Working life of mixed adhesive is typically 10 to 15 minutes, and it usually hardens in less than 45 minutes, depending on temperature and adhesive thickness.

Installation Instructions (continued)



Instruction Set 2: Cast-In Adapters

Adapter type used: PRТА24 or PRТА30
Adhesive used: ADH100, MA320, SS115, or SS140
Bolt-down kit used: None

Step 2a: Apply Adhesive

Apply adhesive to the outside surface of the riser tank adapter.

Hint: If you plan to backfill the same day, the use of MA320, SS115 or SS140 adhesive is recommended because of their quicker cure times. If you have multiple riser installations and do not have bulk adhesive (SS115/SS140), consider using both MA320 and ADH100. Apply just enough MA320 on the outside of the tank adapter for a quick structural joint (cure time is typically less than an hour). A single package of MA320 can be used to provide a structural joint on two or three risers. Then apply ADH100 to the inside of the adapter and the riser joint, for a watertight seal.

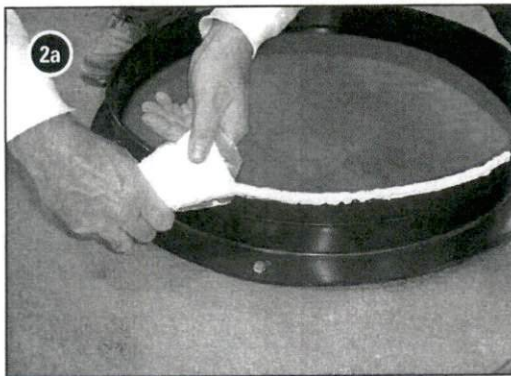

Step 2b: Place Riser

Orient the riser correctly and carefully slide it onto the adapter before the adhesive cures.

Step 2c: Seal Adapter-to-Riser Joint

Apply adhesive to the inside of the adapter and riser joint. Use a putty knife or similar tool to form a continuous fillet between the tank adapter and the inside of the riser.

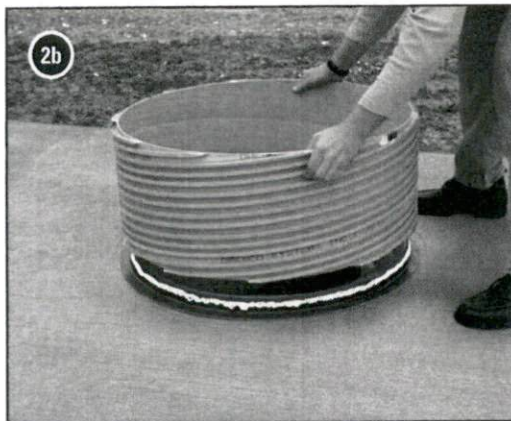

Step 2d: Cure Adhesive

Allow adhesive to harden before backfilling. For ADH100, handling strength is typically achieved within 12 hours. For MA320, cure time is achieved within 30 minutes to 3 hours, depending on temperature.



Installation Instructions (continued)

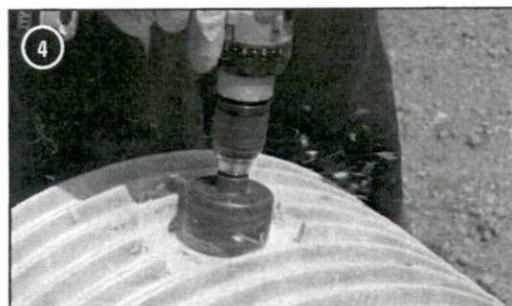
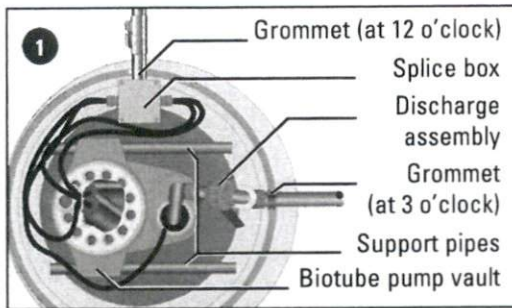

Installing Grommets

Step 1: Mark the Riser

To install grommets in the field, first mark the riser for location of the grommets. (For Perma-Loc risers, you should try to avoid cutting through the pipe seam — the extra thick rib — unless it is unavoidable.)

Step 2: Notch the Ribs

Using a 4-in. (100-mm) grinder or other cutting tool, notch through the PVC ribs to the wall of the PVC riser. Remove an area of ribbing equal to approximately 1 in. (25 mm) larger than the grommet diameter.

Step 3: Remove the Ribs

Using a hammer and chisel, break the notched ribs from the riser. Use a grinder to remove any remaining rib material so that you are left with a smooth area, ensuring a watertight fit. (Hole saws with attached pocket cutters are available from Orenco; they cut away the ribs as the hole is cut, eliminating the need to notch and break the ribs.)

Step 4: Cut the Hole

Using the Grommet Hole Saw Sizing Chart below, select a hole saw for the grommet installation and drill out the opening. (If you are using pipe and grommets other than U.S. nominal sizes, ascertain the correct hole size for your grommet.) Use a deburring tool or knife to deburr the edges of the opening, being careful not to enlarge the opening.

Grommet Hole Saw Sizing Chart

Grommet size (in.)	Hole size (in.)
1/2	1
3/4	1-1/4
1	1-9/16
1-1/4	1-3/4
1-1/2	2-1/8
2	2-3/4
3	3-7/8
4	5

NOTE:

Grommet size = nominal (IPS) pipe size. For more information about grommet dimensions and actual pipe O.D., see Orenco's Grommet Submittal (NSU-RLA-PG-1), available from the Document Library at www.orenco.com.

Step 5: Glue in the Grommet

Install the grommet in the riser. Apply a bead of ADH100 adhesive to the groove of the grommet before inserting it into the riser hole. This will make the grommet more secure and will overcome any imperfections in the drilled hole.

Fiberglass Access Lids

Applications

Oreco® Fiberglass Access Lids provide a secure covering for risers, pump basins, and access ports. Lids fit Perma-Loc™, Ultra-Rib™, Kor Flo™, and Ultra-Corr™ pipe. Oreco Fiberglass Access Lids are capable of supporting a 2500-lb (1134-kg) wheel load; however, they are not designed or recommended for vehicular traffic.

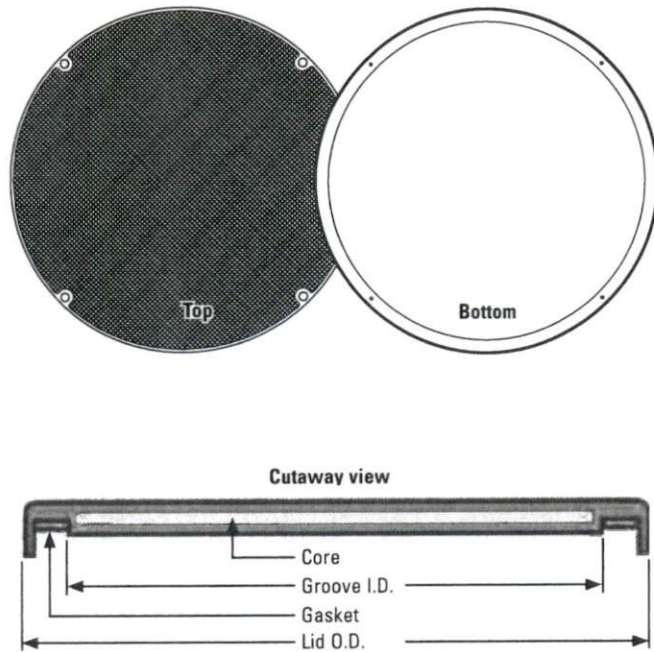

General

Oreco Fiberglass Access Lids are molded using fiberglass reinforced polyester resin encapsulating a wood or structural foam core, for added durability and longevity. The finish is green or brown and the top surface is textured to provide a nonskid surface. Gasketed lids include a polyurethane or neoprene gasket. Lid comes with either two or four 5/16-inch stainless steel flathead socket cap screws and a hex key wrench.

Standard Models

FL18G-4BU, FL21G, FL24G, FL24-4B, FL30G, FL36G, FL48G

Nomenclature

FL □ □ □ - □ □ □ □

FL24G-4BU

- Options:
Blank = green
B = brown
W = warning label (24" and 30" only)
C = custom logo
ATX = AdvanTex logo (24" only)

Attachment method:

- Blank = 2-bolt-hole lid (30" diameter only)
4B = 4-bolt-hole lid (24", and 36" diameter only)
4BU = 4-bolt-hole lid Ultra-Rib (18" and 24" diameter only)
8B = 8-bolt-hole lid (48" diameter only*)

- Options:
G = gasket
V = vent
CF = carbon filter†
I2 = 2" insulation‡
I4 = 4" insulation‡

Lid diameter: 18", 21", 24", 30", 36", 48"

Fiberglass lid

* 48" lids come without bolt holes unless FL48G-8B is ordered and hole locations are specified. For a 48" lid with no holes, to mount on a concrete riser, specify FL48G.

† For more information on this option, see the Carbon Filters Submittal Data Sheet, NSU-RLA-CF-1.

‡ Blue Styrofoam™ has an R-value of 10 per each 2-inch (51mm) increment.

Note: for basin bottoms without bolt holes, specify FL18, FL21, FL24, or FL30.

Materials of Construction

Lid	Fiberglass
Core	Wood (structural foam in FL36)
Gasket	Polyurethane or neoprene

Specifications

Model	FL18G-4BU	FL21G	FL24G-4BU	FL24G-4B	FL30G	FL36G	FL48G
Lid O.D. in. (mm)	20.25 (514)	22.5 (572)	26.25 (667)	25.5 (648)	32.6 (829)	39.63 (1006)	53.88 (1368)
Groove I.D. in. (mm)	17.5 (445)	20.25 (514)	22.75 (578)	23.25 (591)	28.75 (730)	35 (889)	47.5 (1207)
Avg. thickness in. (mm)	0.75 (19)	0.75 (19)	0.75 (19)	0.75 (19)	1.0 (25)	1.5 (38)	1.5 (38)
Weight lb (kg)	7.25 (3.3)	9.75 (4.4)	12.5 (5.7)	12.5 (5.7)	21.5 (9.8)	41.0 (18.6)	103.0 (46.7)
Gasket type	polyurethane	polyurethane	neoprene	polyurethane	polyurethane	polyurethane	polyurethane
Applications	Ultra-Rib	Ultra-Rib Perma-Loc	Ultra-Rib	Perma-Loc	Perma-Loc Kor Flo	Kor Flo	Call for more information

External Splice Box

Applications

The Oreco® External Splice Box attaches outside the access riser of an underground tank. It is engineered specifically for water and wastewater treatment systems and is especially suited for use in locations prone to high groundwater and other wet conditions. Its separate conduit hubs, large volume, and optional dividers make it useful for maintaining isolation of high and low voltage wires where needed. It has four cord grips which accommodate power cords for floats and pumps of 0.170 - 0.470 inches (4.3 - 11.9 mm) in diameter. Unused cord grips can be plugged watertight with the supplied cord grip plugs. Each External Splice Box is provided with a hole-cutting template to simplify installation on the riser.

Standard Models

SBEX1-4, SBEX1-4-P

Nomenclature

SBEX1-4 -

Blank = no divider plates
P = divider plates

External splice box

SBEX1-4 (Or Equivalent), Use as Needed

General

To specify the Oreco External Splice Box for your installation, require the following:

- Watertight for prolonged submergence per UL listing (Type 6P)
- Attachment external to access riser to allow inspection with no need to open the riser lid
- Volume of 100 in.³ (1639 cm³) for easy wiring access and to accommodate multiple wiring configurations
- Bottom entry, so conduit or direct-bury cable always remains below minimum burial depth
- Molded of UL (f1) rated plastic, resistant to cold and UV exposure, suitable for external applications
- Optional divider plates available for isolating high and low voltage wires from separate conduits or direct-bury cable



The External Splice Box is molded of a UL (f1) rated PVC alloy. It has a UL Type 6P listing for prolonged submergence.

External Splice Box (continued)

Physical Specifications

Volume	100 in. ³ (1639 cm ³)
Cord grips	4 per SBEX
Cord grip plugs	3 per SBEX
Cord diameters accommodated	0.170- 0.470 in. (4.3 - 11.9 mm)
Conduit hubs	2
Conduit hub plug	1
Conduit sizes accommodated	¾ in. 1 in. (with coupling) ½ in. (with fitting or bell end)
Diameter of hole into riser	5 in. (127 mm) (hole-cutting template included)

Materials of Construction

Splice box	PVC alloy
Cord grips	Nylon
Cord grip plugs	EPDM rubber
O-rings	Buna rubber
Conduit hub plug	PVC per ASTM D-1784

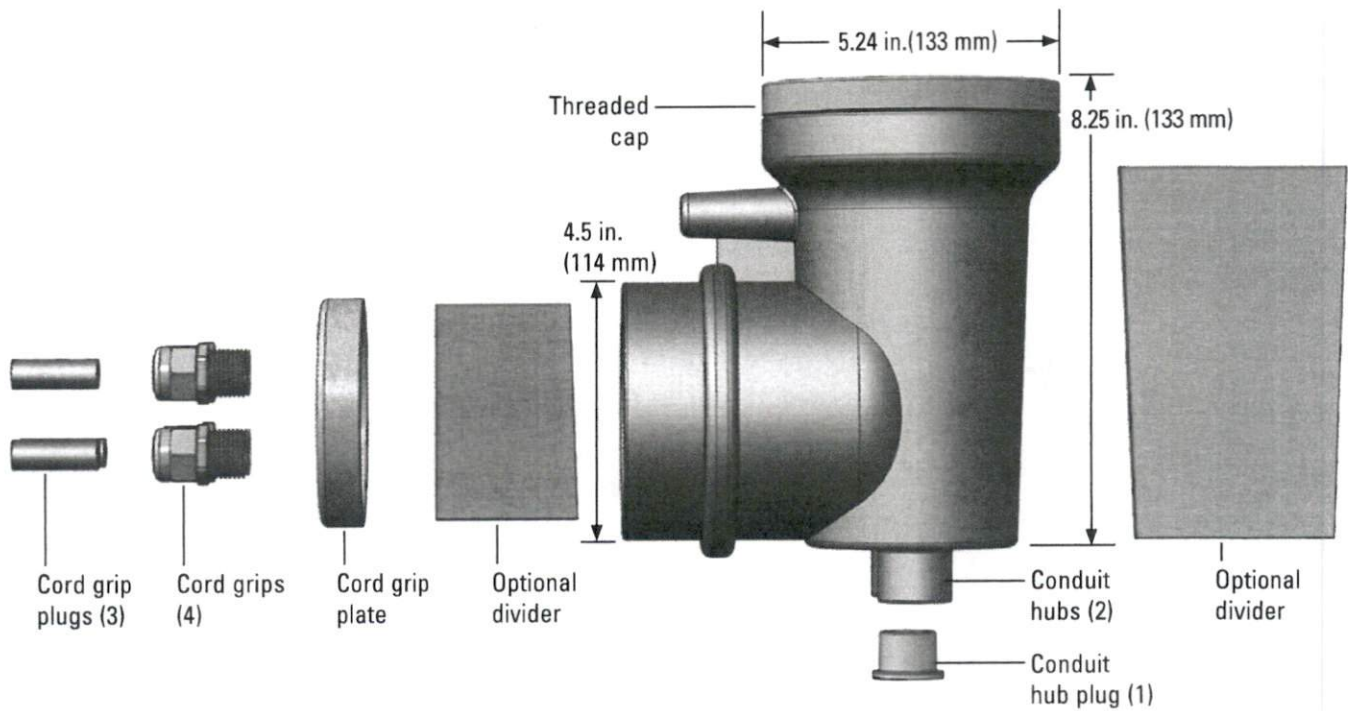

Installer Friendly Series® Control Panels

The innovative **Installer Friendly Series®** control panels from SJE-Rhombus® feature an **easy-to-use touch pad** on the inner door for programming and monitoring on-site installations.

- IFS Single Phase Simplex Demand/Timed Dose Panel
- IFS Single Phase Duplex Demand/Timed Dose Panel

IFS PANEL FEATURES:

- **NEMA 4X** weatherproof enclosure for indoor/outdoor use
- Inner door for added safety
- New innovative circuit board design offers a clean installation
- Separate control and alarm fuses
- Digital display board is standard
- Alarm beacon and horn (85 decibel rating) provides audio/visual warning of alarm condition
- Test / normal / silence switch
- Panel can be easily converted to either demand dose to timed dose in the field
- Easy to read float/pump wiring diagram
- Instruction label on inside cover for viewing and programming digital display
- Includes float switches
- Includes step-by-step installation instructions

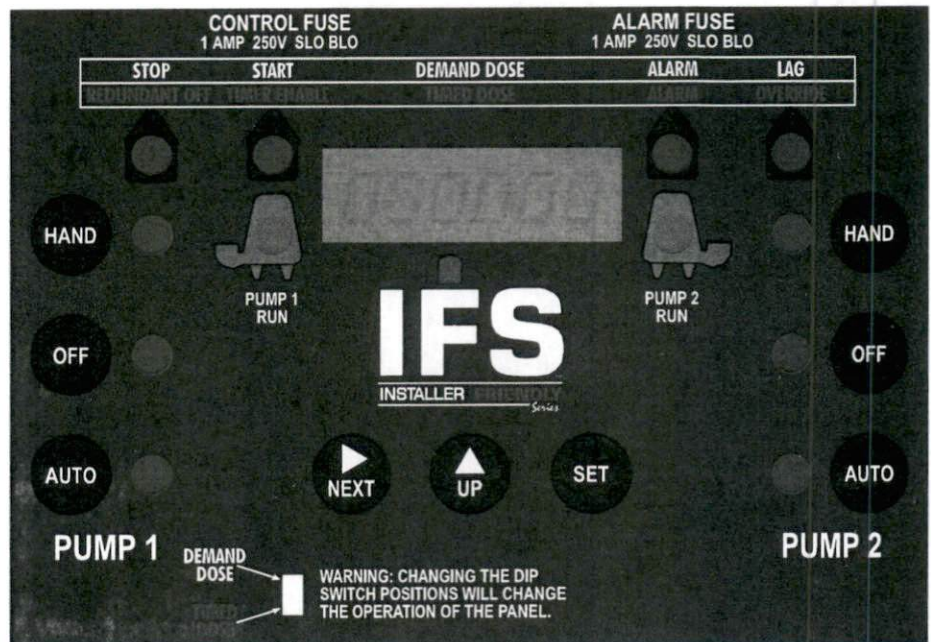
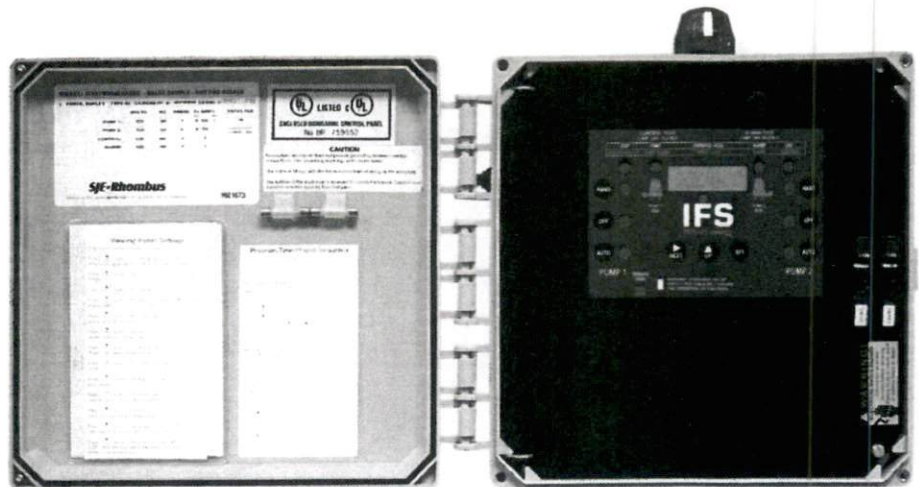

TOUCH PAD/DISPLAY FEATURES:

- Easy-to-use touch pad for programming pump control
- Pump run indicator(s)
- Float status indicators, including float out-of-sequence alarm
- HAND/OFF/AUTO pump control switch(es)
- Hand mode safety feature
- Six digit LED display (now a standard feature) includes:
 - Elapsed time meter(s)
 - Cycle counter(s)
 - Alarm counter
 - Lead/Lag Selector toggles pump operation (duplex models)
 - Float error counter
 - Override counter (timed dose)



SJE Rhombus®

1-888-DIAL-SJE (1-888-342-5753)
www.sjrhombus.com

Installer Friendly Series name and logo Reg. Cdn. Pat. & Tm. Off., Marque Déposée.
 ©SJE-Rhombus 03/11

35/42

INSTALLER FRIENDLY SERIES® - IFS Single Phase Simplex (Demand/TD)

Single phase, simplex demand dose or timed dose, float or C-Level™ controlled system for pump control and system monitoring.

The IFS simplex control panel is designed to control one 120, 208, 240 VAC single phase pump in water and sewage installations. The panel features an easy-to-use touch pad with display on the inner door for programming and system monitoring. The panel configuration can be easily converted in the field to either a timed dose or demand dose.

The optional C-Level™ sensor is a pressure transducer that senses the liquid level in the tank and sends a signal to the IFS panel. Pump activation levels can be adjusted by using the panel touch pad. C-Level™ CL40 sensor operating range is 3-39.9 inches (7.6-101.3 cm). C-Level™ CL100 operating range is 3-99.5 inches (7.6-252.7 cm).

TOUCH PAD FEATURES

- A. **Level Status Indicators** illuminate when floats or set points are activated. Alarm will activate if a float operates out of sequence.
- B. **HOA (Hand-Off-Automatic) Buttons** control pump mode with indication. Hand mode defaults to Automatic when stop level or redundant off level is reached.
- C. **Pump Run Indicator** illuminates when pump is called to run.
- D. **LED Display** shows system information including: level in inches or centimeters (C-Level™ only), mode, pump elapsed time (hh:mm), events (cycles), alarm counter, float error count, timed dose override counter (timed dose only), and ON/OFF times (timed dose only).
- E. **NEXT Push Button** toggles display.
- F. **UP and SET Push Buttons** set pump ON/OFF times (timed dose only) or activation levels (C-Level™ only).

PANEL COMPONENTS

1. **Enclosure base** measures 10 X 8 X 4 inches (25.4 X 20.32 X 10.16 cm). NEMA 4X (ultraviolet stabilized thermoplastic with removable mounting feet for outdoor or indoor use). **Note:** Options, voltage, and amp range selected may change enclosure size and component layout.
2. **Red Alarm Beacon** provides 360° visual check of alarm condition.
3. **Exterior Alarm Test/Normal/Silence Switch** allows horn and light to be tested and horn to be silenced in an alarm condition. Alarm automatically resets once alarm condition is cleared.
4. **Alarm Horn** provides audio warning of alarm condition (83 to 85 decibel rating).
5. **Circuit Breaker** (optional) provides pump disconnect and branch circuit protection.
6. **Power Relay** controls pump by switching electrical lines. Definite purpose contactor used when pump full load amps are above 15.
7. **Float Connection Terminal Block**
8. **Incoming Control/Alarm Power & Pump Terminal Block**
9. **Control Power Indicator/Fuse** indicator light illuminates if control power is present in panel. Alarm will activate if control fuse is blown.
10. **Alarm Power Indicator/Fuse** indicator light illuminates if alarm power is present in panel.
11. **Ground Lug**

NOTE: Schematic/Wiring Diagram and Pump Specification Label are located inside the panel on enclosure cover

OPTIONAL FEATURE

- **34" (86.36cm) Panel Mounting Post** (Factory Installed). Includes Duplex Installation Kit (Enclosure upsized to 10" x 8" x 6" (25.4 x 20.32 x 15.24 cm). Max. Enclosure size 14" x 12" x 6" (35.56 x 30.48 x 15.24 cm)

SEE BACKSIDE FOR COMPLETE LISTING OF AVAILABLE OPTIONS.

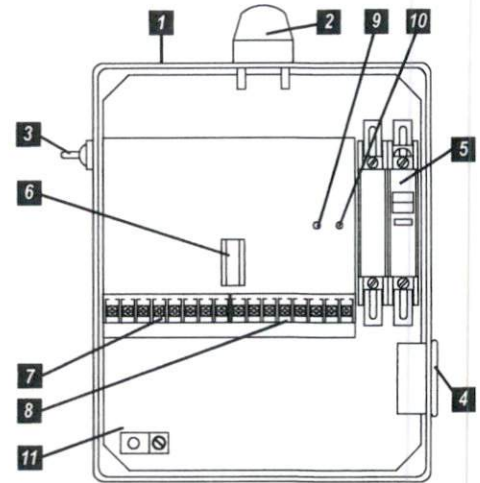
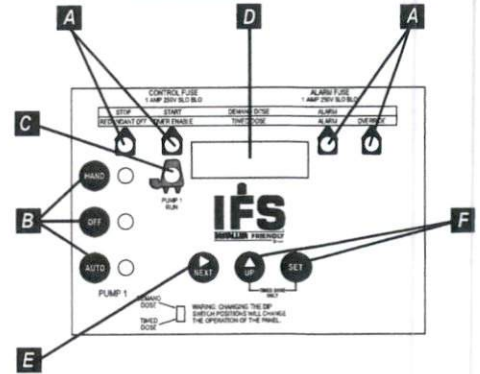

Model Shown IFS11W114X8AC

Reg. Cdn Pat. & TM Off
C-Level™ Sensor US Patent 8,336,385. Other patents pending.

FEATURES

- Entire control system is UL Listed to meet and/or exceed industry safety standards
- Dual safety certification for the United States and Canada
- Standard package includes:
Demand Dose - three 20' SJE MilliAmpMaster™ control switches
Timed Dose - two 20' SJE MilliAmpMaster™ control switches
- Complete with step-by-step installation instructions
- Three-year limited warranty



SJE Rhombus

PO Box 1708, Detroit Lakes, MN 56502

1-888-DIAL-SJE • 1-218-847-1317

1-218-847-4617 Fax

email: sje@sjerhombus.com

www.sjerhombus.com

IFS
2
1
W
1
1
4
H
8AC 17G 10E 15A

MODEL IFS

- MODEL TYPE**
- 1 = SPLX TIMED DOSE (includes option 8AC standard) \$824.00
 - 2 = SPLX DEMAND DOSE (includes option 8AC standard) \$852.00
- ALARM PACKAGE**
- 1 = alarm package (includes test/normal/silence switch, fuse, red light & horn) Base
- ENCLOSURE RATING**
- W = NEMA 4X Base
- STARTING DEVICE**
- 1 = 120/208/240 VAC Base
 - 9 = 120 VAC Base
- PUMP FULL LOAD AMPS**
- 0 = 0-7 FLA Base
 - 1 = 7-15 FLA Base
 - 2 = 15-20 FLA \$80.00
- PUMP DISCONNECTS**
- 0 = no pump disconnect Base
 - 4 = circuit breaker
 - 120 VAC (must select starting device option 9) \$35.00
 - 120/208/240 VAC (must select starting device option 1) \$70.00
- SWITCH APPLICATIONS**
- H = floats (Timed dose = timer enable and alarm / Demand dose = stop, start, and alarm) (select 17 option) Base
 - X = no floats
 - timed dose -\$50.00
 - demand dose -\$75.00
 - C = C-Level™ sensor (must select 24 or 29 option)
 - (select option 3E and/or 4A & 4D for high water alarm and/or redundant off floats)
 - timed dose -\$50.00
 - demand dose -\$75.00

Note: Pump down applications only.

Industry practices suggest that a secondary device, such as a float switch, be used for redundant activation of the high level alarm and pump shut off.

OPTIONS Listed below

	LIST PRICE			LIST PRICE
<input type="checkbox"/> 1J Duo alarm inputs	\$25.00	<input type="checkbox"/> 11D NEMA 4X alarm panel		
<input type="checkbox"/> 3A Alarm flasher	\$50.00	<input checked="" type="checkbox"/> 15A Control / Alarm circuit breaker		\$85.00
<input type="checkbox"/> 3B Manual alarm reset	\$90.00	<input type="checkbox"/> 16A 10' cord in lieu of 20' (per float)		-\$2.00
<input type="checkbox"/> 3E High water alarm float (must select 17 option)	\$25.00	<input type="checkbox"/> 16B 15' cord in lieu of 20' (per float)		-\$1.00
(Available only when Switch Applications = C)				
<input type="checkbox"/> 4A Redundant off (select option 4D if floats are required)		<input type="checkbox"/> 16C 30' cord in lieu of 20' (per float)		\$5.00
Demand Dose	\$55.00	<input type="checkbox"/> 16D 40' cord in lieu of 20' (per float)		\$15.00
Timed Dose	\$0.00	<input type="checkbox"/> 17C Sensor Float® / internally weighted ▲ (per float)		\$5.00
<input type="checkbox"/> 4D Redundant off float		<input type="checkbox"/> 17D Sensor Float® / externally weighted ▲ (per float)		\$7.00
(must select 4A option) (must select 17 option)	\$25.00	<input checked="" type="checkbox"/> 17G MilliAmpMaster™ / pipe clamp ● (per float)		\$0.00
<input type="checkbox"/> 6A Auxiliary alarm contacts, form C	\$40.00	<input type="checkbox"/> 17H MilliAmpMaster™ / externally weighted ● (per float)		\$7.00
<input checked="" type="checkbox"/> 8AC Display board includes: ETM counter, events (cycles) counter, alarm counter, and override counter (timed dose only). (Included as standard.)	\$0.00	<input type="checkbox"/> 17J Sensor Float® / pipe clamp ▲ (per float)		\$0.00
<input checked="" type="checkbox"/> 10E Lockable latch - NEMA 4X	\$40.00	<input type="checkbox"/> 18A Timer override float		
<input type="checkbox"/> 10F Lightning arrestor (must select pump circuit breaker, control and alarm power combined)	\$230.00	(timed dose float panel only)		\$25.00
<input type="checkbox"/> 10K Anti-condensation heater	\$100.00	<input type="checkbox"/> 24E C-Level™ CL40 sensor with 4' vent tube & 20' cord		\$280.00
<input type="checkbox"/> 10P Panel Mounting Post (Factory Installed. Includes Duplex Install. Kit)(Enclosure upsized to 10"x8"x6". Max 14"x12"x6")	\$110.00	<input type="checkbox"/> 24F C-Level™ CL40 sensor with 4' vent tube & 40' cord		\$310.00
<input type="checkbox"/> 11C NEMA 1 alarm panel (must select option 6A)	\$80.00	<input type="checkbox"/> 24G C-Level™ CL40 sensor with 8' vent tube & 20' cord		\$285.00
		<input type="checkbox"/> 24H C-Level™ CL40 sensor with 8' vent tube & 40' cord		\$315.00
		<input type="checkbox"/> 24X No C-Level™ CL40 sensor		\$0.00
		<input type="checkbox"/> 29A C-Level™ CL100 sensor w/10' vent tube & 20' cord		\$290.00
		<input type="checkbox"/> 29B C-Level™ CL100 sensor w/10' vent tube & 40' cord		\$320.00
		<input type="checkbox"/> 29X No C-Level™ CL100 sensor		\$0.00

● Mechanically-activated ▲ Mercury-activated

If additional features are required, call the factory for a quote on an Engineered Custom control panel.

SAMPLE

IFS
1
1
W
9
1
4
H
8AC 10E17G

- Model Type** _____
- Alarm Package** _____
- Enclosure Rating** _____
- Starting Device** _____
- Pump Full Load Amps** _____
- Pump Disconnects** _____
- Switch Application** _____
- Options: Display, Lockable Latch, SJE MilliAmpMaster™/pipe clamp**

IFS1 See Price List
1 Base
W Base
9 Base
1 Base
4 \$35.00
H Base
8AC \$0.00
10E \$40.00
17G \$0.00

TOTAL LIST PRICE \$XXX.XX

"QUALITY PUMPS SINCE 1939"

Product information presented here reflects conditions at time of publication. Consult factory regarding discrepancies or inconsistencies.



REPAIR
PUMP - N152



SECTION: 2.20.047

FM1919

0110

Supersedes

1108

MAIL TO: P.O. BOX 16347 • Louisville, KY 40256-0347
SHIP TO: 3649 Cane Run Road • Louisville, KY 40211-1961
(502) 778-2731 • 1 (800) 928-PUMP • FAX (502) 774-3624

visit our web site:
www.zoeller.com

COMPARE THESE FEATURES

- Durable cast iron construction
- Model 151 comes standard with a glass-filled polypropylene base
- Corrosion resistant powder coated epoxy finish
- Stainless steel lifting handle
- Assembled with stainless steel bolts
- Non-clogging engineered thermoplastic vortex impeller design
- Model 151 - 1/3 HP passes 1/2" spherical solids
- Model 152 - .4 HP passes 3/4" spherical solids
- Model 153 - 1/2 HP passes 3/4" spherical solids
- Motor - 60 Hz, 3450 RPM, oil-filled, hermetically sealed, automatic reset thermal overload protected
- Carbon/Ceramic seals
- Upper sleeve bearing and lower ball bearing running in bath of oil
- 20 ft. UL Listed power cord with molded 3-wire plug
- 1 1/2" NPT vertical discharge
- BN and BE standard models include a 20 ft. variable level float switch
- Operates at temperatures to 130°F (54°C) in effluent applications
- All models include a 1 1/2" x 2" PVC adapter fitting

Note: The sizing of effluent systems normally requires variable level float(s) controls and properly sized basins to achieve required pumping cycles or dosing timers with nonautomatic pumps.



MAIL TO: P.O. BOX 16347
Louisville, KY 40256-0347
SHIP TO: 3649 Cane Run Road
Louisville, KY 40211-1961
(502) 778-2731 • 1 (800) 928-PUMP
FAX (502) 774-3624



Manufacturers of . . .

"QUALITY PUMPS SINCE 1939"

© Copyright 2010 Zoeller Co. All rights reserved.

151/152/153 EFFLUENT SERIES

(For Pump Prefix Identification see News & Views 0052)

"DOSE-MATE"

FOR SEPTIC TANK - LOW PRESSURE PIPE (LPP)
AND ENHANCED FLOW STEP SYSTEMS

**EFFLUENT
SUBMERSIBLE
1 1/2" NPT DISCHARGE**



Model N152/N153
High Head
Effluent



MODELS AVAILABLE

- N151/N152/N153 & E151/E152/E153 nonautomatic
- BN151/BN152/BN153 & BE151/BE152/BE153 packaged with Piggyback Variable Level Float Switch
- 1/3, .4 & 1/2 HP, 1Ph 115V or 230V



Model BN152/BN153
High Head
Effluent



38/42

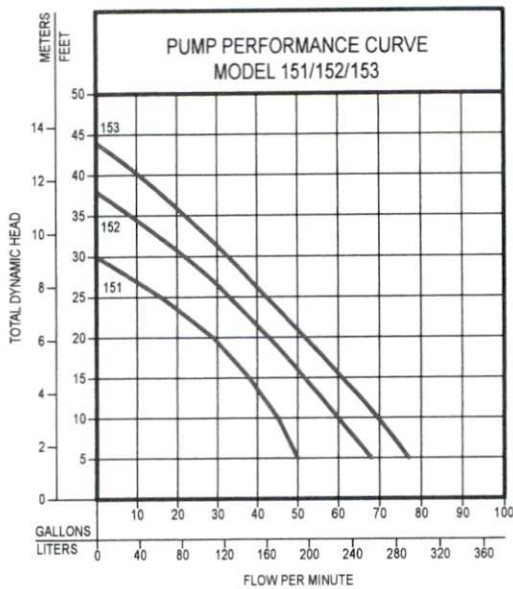

**TOTAL DYNAMIC HEAD/FLOW
PER MINUTE
EFFLUENT AND DEWATERING**

MODEL		151		152		153	
Feet	Meters	Gal.	Liters	Gal.	Liters	Gal.	Liters
5	1.5	50	189	69	261	77	291
10	3.0	45	170	61	231	70	265
15	4.6	38	144	53	201	61	231
20	6.1	29	110	44	167	52	197
25	7.6	16	61	34	129	42	159
30	9.1	--	--	23	87	33	125
35	10.7	--	--	--	--	22	85
40	12.2	--	--	--	--	11	42
Shut-off Head:		30 ft. (9.1m)		38 ft. (11.6m)		44 ft. (13.4m)	

014508B

**CONSULT FACTORY FOR
SPECIAL APPLICATIONS**

- Timed dosing panels available
- Electrical alternators, for duplex systems, are available and supplied with an alarm
- Variable level control switches are available for controlling single phase systems
- Double piggyback variable level float switches are available for variable level long and short cycle controls
- Sealed Qwik-Box available for outdoor installations - See FM1420
- Over 130°F (54°C) special quotation required

151/152/153 Series

151/152/153 MODELS					Control Selection	
Model	Volts-Ph	Mode	Amps		Simplex	Duplex
N151	115	1	Non	6.0	1	2 or 3
BN151	115	1	Auto	6.0	Included	2 or 3
E151	230	1	Non	3.2	1	2 or 3
BE151	230	1	Auto	3.2	Included	2 or 3
N152	115	1	Non	8.5	1	2 or 3
BN152	115	1	Auto	8.5	Included	2 or 3
E152	230	1	Non	4.3	1	2 or 3
BE152	230	1	Auto	4.3	Included	2 or 3
N153	115	1	Non	10.5	1	2 or 3
BN153	115	1	Auto	10.5	Included	2 or 3
E153	230	1	Non	5.3	1	2 or 3
BE153	230	1	Auto	5.3	Included	2 or 3

SELECTION GUIDE

1. Single piggyback variable level float switch or double piggyback variable level float switch. Refer to FM0477.
2. See FM0712 for correct model of Electrical Alternator E-Pak.
3. Variable level control switch 10-0743 used as a control activator, specify duplex (3) or (4) float system.

CAUTION

All installation of controls, protection devices and wiring should be done by a qualified licensed electrician. All electrical and safety codes should be followed including the most recent National Electrical Code (NEC) and the Occupational Safety and Health Act (OSHA).

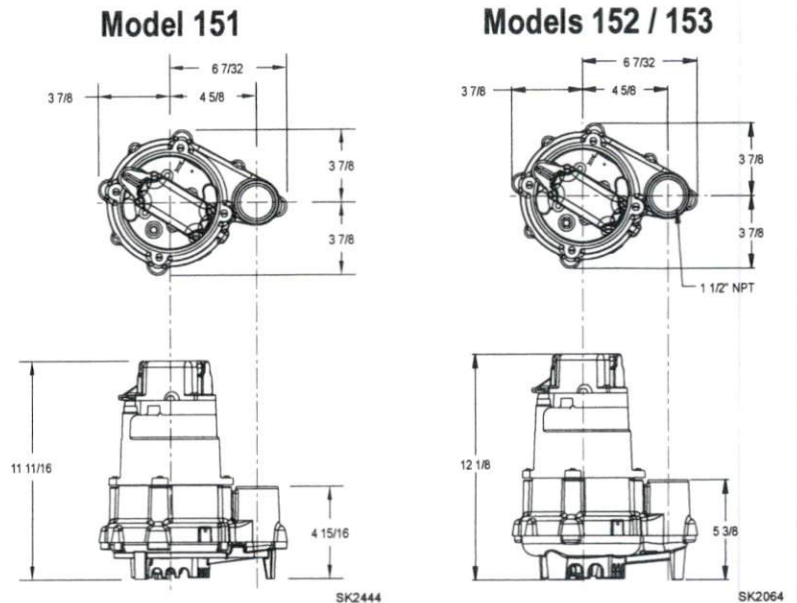

"Easy assembly"
(pump & discharge pipe not included.)

OPTIONAL PUMP STAND P/N 10-2421

- Reduces potential clogging by debris
- Replaces rocks or bricks under the pump
- Made of durable, noncorrosive ABS
- Raises pump 2" off bottom of basin
- Provides the ability to raise intake by adding sections of 1 1/2" or 2" PVC piping
- Attaches securely to pump
- Accommodates sump, dewatering and effluent applications

NOTE: Make sure float is free from obstruction.

RESERVE POWERED DESIGN

For unusual conditions a reserve safety factor is engineered into the design of every Zoeller pump.

"QUALITY PUMPS SINCE 1939"

Product information presented here reflects conditions at time of publication. Consult factory regarding discrepancies or inconsistencies.



SECTION: 5.10.280

FM0531

1009/2

Supersedes

1009

MAIL TO: P.O. BOX 16347 • Louisville, KY 40256-0347
 SHIP TO: 3649 Cane Run Road • Louisville, KY 40211-1961
 (502) 778-2731 • 1 (800) 928-7867 • FAX (502) 774-3624

visit our web site:
www.zoeller.com

SPECIFICATIONS

EFFLUENT/SUMP SIMPLEX SYSTEM

ZOELLER SUBMERSIBLE DEWATERING OR EFFLUENT PUMPS

SEAL	SOLIDS	DISCHARGE	MATERIAL	MODELS								
Single	1/2"	1 1/2" NPT	Cast Iron	53	57	98	140	151				
Single	1/2"	1 1/2" NPT	Cast Bronze	55	59							
Single	5/8"	1 1/2" NPT	Cast Iron	137	191							
Single	5/8"	1 1/2" NPT	Cast Bronze	139								
Single	3/4"	1 1/2" NPT	Cast Iron	145	152	153						
Single	3/4"	1 1/2", 2", or 3 NPT	Cast Iron	161	163	165	185	186	188	189		
Double	1/2"	1 1/2"	Cast Iron	4140								
Double	3/4"	1 1/2", 2", or 3 NPT	Cast Iron	4145	4161	4163	4165	4185	4186	4188	4189	

SIMPLEX SYSTEM

Furnish a Zoeller Submersible Pump Model N152 Single Seal or Model _____ Double Seal, with a capacity of 34.51 GPM against a Total Dynamic Head of 18.1 feet. Motor Specification: 115 Voltage, 60 Cycles, 1 Phase, 0.4 HP. Discharge to be 1 1/2 inch NPT. Optional _____ 2 inch NPT or _____ 3 inch NPT (161/4161 - 189/4189). Cord length to be 20 feet. Pumps will pass _____ 1/2 inch solids (53,55,57,59, 98, 140/4140 & 151 Series) or _____ 5/8 inch solids (137 & 139 Series) or 3/4 inch solids (145/4145, 152, 153, 161/4161, 163/4163, 165/4165, 185/4185, 186/4186, 188/4188 & 189/4189 Series.) Pumps shall be _____ UL Listed, CSA Certified, SSPMA certified, _____ State of Wisc. approved, _____ other (Specify _____).

SINGLE PHASE PUMPS

GENERAL

Pump motor shall be hermetically sealed, submersible type operating in a high quality dielectric oil for cooling the windings and for lubrication of the motor bearings and ceramic-carbon shaft seal. Single phase motor shall have internal automatic resetting, thermal overload protection. Construction shall be of _____ cast iron with 100% baked-on powder coated epoxy finish for corrosion resistance and longer casting durability (or _____ cast bronze). All fasteners and external metal parts shall be of stainless steel. Impeller shall be of vortex non-clog design. (Addition noted below.) Check applicable series:

- _____ 53 (cast iron) _____ 55 (cast bronze) series pump shall have a shaded pole motor. Impeller, with metal insert, and base shall be of glass reinforced molded material. Switch case shall be of cast or molded material. Guard and handle shall be of stainless steel.
- _____ 57 (cast iron) _____ 59 (cast bronze) series pump shall have a shaded pole motor. Guard and handle shall be of stainless steel.
- _____ 98 (cast iron) series pump shall have 1/2 HP PSC motor.

- _____ 137 (cast iron) _____ 139 (cast bronze) series pump shall have 1/2 HP split phase motor with current sensing, starting relay enclosed in switch housing.
- _____ 151 (.33 HP) 152 (.4 HP) _____ 153 (1/2 HP) series pump shall have a permanent split capacitor motor. The impeller shall be "glass reinforced thermoplastic." Motor housing shall be cast iron.
- _____ 145 (3/4 HP) _____ 140 (1 HP) series pump shall have a permanent split capacitor motor with capacitor in the switch housing attached to the pump. The impeller shall be "glass reinforced thermoplastic." Motor housing shall be cast iron. Discharge shall be a permanently affixed 1 1/2 inch female NPT hub.
- _____ 4140 (1 HP cast iron) _____ (4145 (3/4 HP cast iron) series pump with double carbon/ceramic shaft seals shall have a 1 HP permanent split capacitor motor with capacitor in the switch housing attached to the pump. The impeller shall be "glass reinforced thermoplastic." Motor housing shall be cast iron. Discharge shall be a permanently affixed 1 1/2 inch female NPT hub. The lower seal cavity shall be oil-filled.
- _____ 161 (1/2 HP) _____ 163 (1/2 HP) _____ 165 (1 HP) cast iron series pump shall have a permanent split capacitor motor with run capacitor and magnetic contactor enclosed

40/42



Pressure Filter for Pump Discharge

FEATURES

- ❖ Low maintenance
- ❖ Easy to install and service
- ❖ Economical
- ❖ Extends life of drain field
- ❖ Improves effluent quality
- ❖ The last line of defense before the laterals
- ❖ Vortex scrubbing action helps keep filter clean providing maximum maintenance intervals
- ❖ Uses a S.S. filter screen with .062 diameter holes
- ❖ Provides a 69.52 sq. in. or 41% open area which allows the filter to pass 83.8 GPM at 1 PSI
- ❖ Assures quality effluent with lower TSS levels, keeping pressurized systems functioning at 100% efficiency
- ❖ Low head loss .5002 ft. or .21 PSI
- ❖ Flow rate with clean screen 120,672 GPD @ 1 PSI
- ❖ Flow rate with 95% plugged screen 114,912 GPD @ 1.8 PSI
- ❖ Job ready with 2" schedule 80 union and tailpiece attached (STF-100)
- ❖ Field assemble does not include union or tailpiece (STF-100A2)
- ❖ Use optional filter socks to filter smaller particles

FILTER SCREEN
PERFORATED METAL
22 GA STAINLESS STEEL TYPE 304
WITH 0.062 HOLES

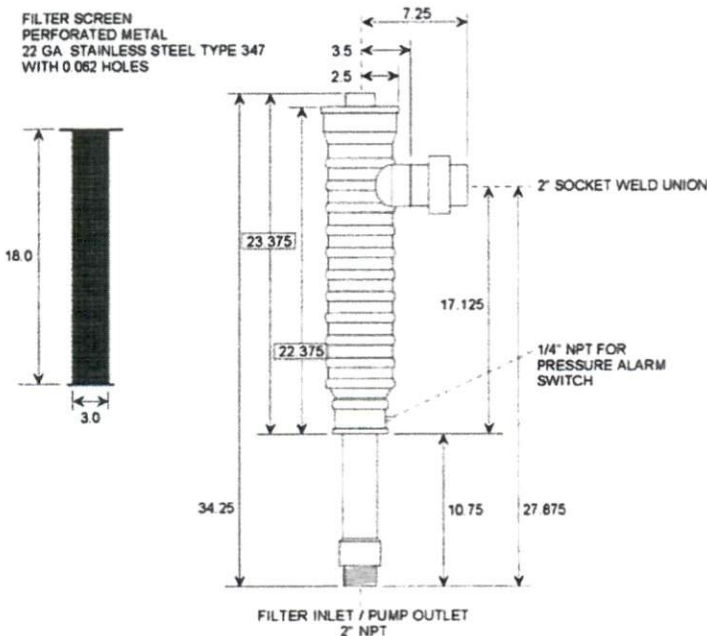

Order part No. STF-100
STF-100A2

CAD detail drawing available in DXF format

RELATED PRODUCTS

- STF-104-600M page 14
- STF-104-150190M page 14
- STF-104TN page 14
- STF-101 page 14
- STF-101A page 14
- STF-107 page 14
- STF-102 page 14
- STF-FC page 14
- STF-150 page 14
- STF-103B page 14
- STF-105 page 14

Locate on pump discharge.

U.S. Patent # 5, 885, 452
Canada Patent # 2, 237, 751

Safety Nets (as needed).

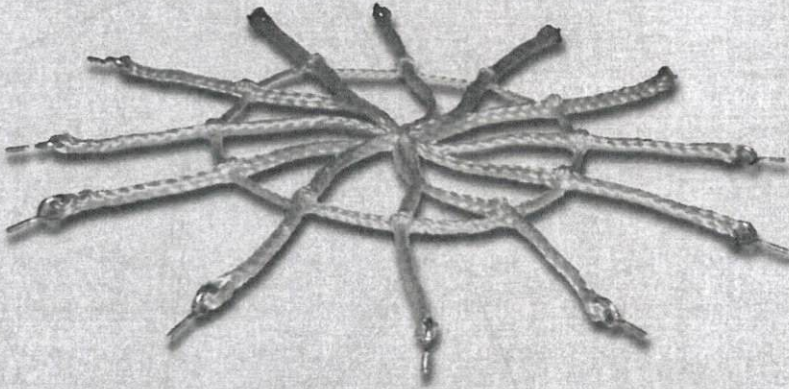

FEATURES

- ❖ Use as a security measure to keep persons, especially children, from accidental entry while systems are being serviced or any other instance where a cover is removed
- ❖ Available to fit 18", 24", and 30" diameter risers
- ❖ Open areas in web are large enough to allow tanks to be pumped without having to remove the security net
- ❖ Installs easily in our segmented riser and others

Order part No. STF-N18
STF-N24
STF-N30

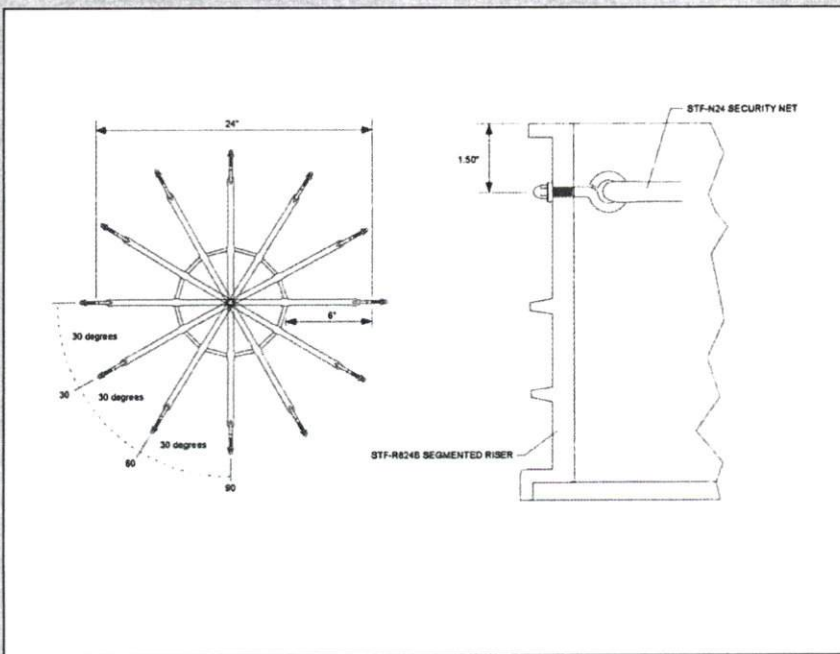

CAD detail drawing available in DXF format

RELATED PRODUCTS

- STF-C124 page 5
- STF-APC24G page 6
- STF-APC24B page 6
- STF-R824B page 9
- STF-AR24 page 9
- STF-APC24GI-075 page 14
- STF-APC24BI-075 page 14
- STF-APC24GI-100 page 14
- STF-APC24BI-100 page 14
- STF-APL24G page 14
- STF-APL24B page 14

U.S. Patent Pending

Harnett County Department of Public Health Improvement Permit

A building permit cannot be issued with only an Improvement Permit

ISSUED TO: _____ PROPERTY LOCATION: _____
 SUBDIVISION _____ LOT # _____
 NEW REPAIR EXPANSION Site Improvements required prior to Construction Authorization Issuance: _____
 Type of Structure: _____
 Proposed Wastewater System Type: _____
 Projected Daily Flow: _____ GPD
 Number of bedrooms: _____ Number of Occupants: _____ max
 Basement Yes No
 Pump Required: Yes No May be required based on final location and elevations of facilities
 Type of Water Supply: Community Public Well Distance from well _____ feet Permit valid for: Five years
 Permit conditions: _____ No expiration

Authorized State Agent: _____ Date: _____ SEE ATTACHED SITE SKETCH
 The issuance of this permit by the Health Department in no way guarantees the issuance of other permits. The permit holder is responsible for checking with appropriate governing bodies in meeting their requirements. This site is subject to revocation if the site plan, plat, or the intended use changes. The Improvement Permit shall not be affected by a change in ownership of the site. This permit is subject to compliance with the provisions of the Laws and Rules for Sewage Treatment and Disposal and to conditions of this permit.

Construction Authorization (Required for Building Permit)

The construction and installation requirements of Rules .1950, .1952, .1954, .1955, .1956, .1957, .1958, and .1959 are incorporated by references into this permit and shall be met. Systems shall be installed in accordance with the attached system layout.

ISSUED TO: Robert Whittaker PROPERTY LOCATION: 88 Brookview Court
 SUBDIVISION The Creek LOT # 4
 Facility Type: Ext SFD New Expansion Repair
 Basement? Yes No Basement Fixtures? Yes No
 Type of Wastewater System** _____ (Initial) Wastewater Flow: 360 GPD
 (See note below, if applicable) _____ (Repair)

<u>Installation Requirements/Conditions</u>	Number of trenches _____	Trench Spacing: _____ Feet on Center
Septic Tank Size _____ gallons	Exact length of each trench _____ feet	Soil Cover: _____ inches
Pump Tank Size _____ gallons	Trenches shall be installed on contour at a Maximum Trench Depth of: _____ inches (Trench bottoms shall be level to +/- 1/4" in all directions)	(Maximum soil cover shall not exceed 36" above the trench bottom)
Pump Requirements: _____ ft. TDH vs. _____ GPM		Aggregate Depth: _____ inches below pipe _____ inches above pipe _____ inches total
Conditions: <u>See attached sheets fo all specifications.</u>		

**WATER LINES (INCLUDING IRRIGATION) MUST BE 10FT. FROM ANY PART OF SEPTIC SYSTEM OR REPAIR AREA.
 NO UTILITIES ALLOWED IN INITIAL OR REPAIR DRAIN FIELD AREA.**

****If applicable: I understand the system type specified is different from the type specified on the application. I accept the specifications of this permit.**

Owner/Legal Representative Signature: _____ Date: _____

This Construction Authorization is subject to revocation if the site plan, plat, or the intended use changes. The Construction Authorization shall not be transferred when there is a change in ownership of the site. This Construction Authorization is subject to compliance with the provisions of the Laws and Rules for Sewage Treatment and Disposal and to the conditions of this permit. SEE ATTACHED SITE SKETCH

Authorized State Agent: _____ RSMS Date: 1/22/21
 Construction Authorization Expiration Date: 4/22/21



Engineers and Soil Scientists

Agri-Waste Technology, Inc.
501 N. Salem Street, Suite 203
Apex, North Carolina 27502
919-859-0669
www.agriwaste.com

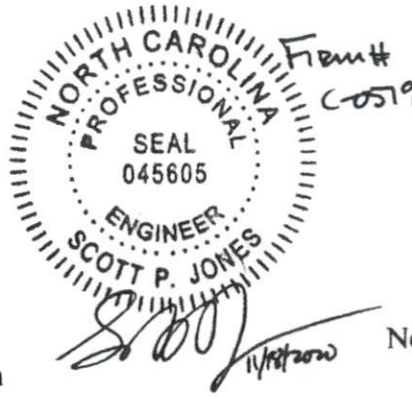

November 18, 2020

Harnett County Environmental Health
307 W Cornelius Harnett Boulevard
Lillington, NC 27546

SUBJECT: Repair Septic System Layout & Design – Whittaker Property
Lot 4 - The Creek
88 Brookview Court
Angier, NC 27501
PIN# 0672-60-2805.000

To Whom It May Concern:

Enclosed please find a layout and design package for a repair pressure manifold septic system for the property located at 88 Brookview Court Angier, NC 27501. The repair system is designed for a three (3) bedroom single-family residence. The design flow is 360 gallons/day. AWT laid out additional line on the property to utilize as much area as feasible for the repair system. The existing chamber lines will be used in the repair system and any damaged chambers shall be replaced. The existing septic tank and pump tank are proposed to be used pending leak tests. The existing septic tank shall be upfitted with single-piece access risers and an effluent filter.

The repair system will utilize the following components:

- Existing 1,000-gallon septic tank
- Existing 1,000-gallon pump tank
- New Pressure Manifold
- Control Panel with Elapsed Timer and Counter
- Accepted Drainfield Product

I appreciate your time and efforts in reviewing this application. If you have any questions or comments, please feel free to contact me at 919-859-0669.

Best Regards,

Scott P. Jones, P.E.
Project Engineer



Engineers and Soil Scientists

Agri-Waste Technology, Inc.
501 N. Salem Street, Suite 203
Apex, North Carolina 27502
919-859-0669
www.agriwaste.com

**FINAL DESIGN
NOT RELEASED FOR
CONSTRUCTION**

**Whittaker Property Repair WWTS
Lot 4 – The Creek
88 Brookview Court
Angier, NC 27501
Harnett County
PIN# 0672-60-2805.000**

Plans and Specifications for Wastewater Treatment System

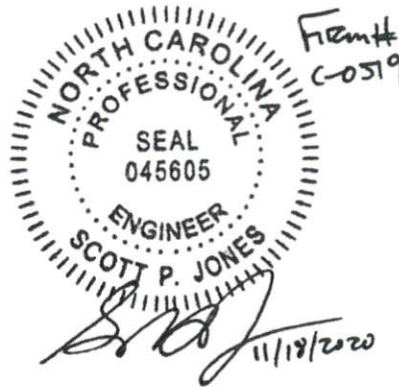

Date: November 18, 2020

Consultants: Scott P. Jones, PE
Project Engineer
sjones@agriwaste.com
Agri-Waste Technology, Inc.
501 N. Salem Street, Ste 203
Apex, NC 27502
Office: 919-859-0669



Engineers and Soil Scientists

Agri-Waste Technology, Inc.
501 N. Salem Street, Suite 203
Apex, North Carolina 27502
919-859-0669
www.agriwaste.com

**FINAL DESIGN
NOT RELEASED FOR
CONSTRUCTION**

**Whittaker Property Repair WWTS
Lot 4 – The Creek
88 Brookview Court
Angier, NC 27501
Harnett County
PIN# 0672-60-2805.000**

Plans and Specifications for Wastewater Treatment System

- Narrative Description of System
- Design Spreadsheets
- Drawings of Proposed System
- Tank Specification Sheets
- Access Riser Adapters, Risers, Lids, and Safety Net
- Effluent Filter Specification
- Pump Specification
- Specification for Control Panel and Floats
- Pressure Filter

Narrative Description of Wastewater Treatment System

The Wastewater Treatment System that has been designed considers the following components:

- Septic Tank
- Pump Tank
- Discharge Pump and Filter
- Pressure Manifold
- Control Panel and Floats
- Drainfield

Due to the pump in this system, it is recommended that a Certified Operator be contracted to maintain this system.

Septic Tank

The existing 1,000-gallon septic tank will be used for this system pending a leak test. The existing septic tank shall be upfitted with single-piece access risers and an effluent filter. If the existing septic tank does not pass the leak test, a new 1,000-gallon (minimum) septic tank will be installed for this system. A 4" effluent filter will be installed in the outlet end of the septic tank. Access risers (24") will be installed on both the inlet and outlet ends of the septic tank. To facilitate the installation of the access risers, the tank will have riser adapters cast into the top of the tank during tank construction. Inner lids or safety nets will be included with the risers. Rubber boots (4") shall be cast into the inlet and outlet end of the tank. Waste that exits the septic tank will flow into the pump tank.

Pump Tank

The existing 1,000-gallon pump tank will be used for this system pending a leak test. If the existing pump tank does not pass the leak test, a new pump tank, sized to a minimum of 1,000 gallons AND with 24 hours of emergency storage, will be installed for this system. A 24" or 30" access riser will be installed on the outlet end of the pump tank. To facilitate the installation of the access riser, the tank will have a riser adapter cast into the top of the tank during tank construction. Rubber boots (4") shall be cast into the inlet and outlet end of the tank. The pump tank will house the discharge pump.

Discharge Pump and Filter

The system will pump to a conventional pressure manifold drainfield. The discharge pump will be a submersible pump and will be outfitted with a check valve, pressure filter, union and gate valve on the discharge pipe. The pressure filter will reduce the potential of solids entering the drainfield.

Control Panel and Floats

One control panel will be required for this wastewater system. The existing or new panel shall meet the following requirements:

This panel will control operation of the discharge pump. Three floats will be installed; "Pump Off", "Pump On" and "High Water Alarm". The pump off float is set to keep the pump covered with effluent at all times. The pump on float is set based on the intended field dose volume. When the dose volume is reached in the tank (as the water level rises), the pump on float will engage (the pump off float will also be "up") and pump the tank contents to the drainfield. As the liquid level drops, the pump on float will drop and then once the pump off float drops, the pump will cease pumping. In the event of a power outage, pump failure or extremely high inflow to the system, the effluent level may rise above the pump on float. If the effluent level rises sufficiently, the high-water alarm will activate. The high-water alarm is set at 6" above the pump on float and allows for a minimum of one-day storage in the pump tank.

Drainfield

The drainfield will utilize chamber product for the repair system. A six (6) tap conventional pressure manifold will be utilized for the repair system. Trench depth for the system will be 18" and the width will be 36".

If there are questions, comments, or concerns regarding the operation of the system, please contact AWT at 919-859-0669.

Conventional PM System - Design Summary Page



Engineers and Soil Scientists

Agri-Waste Technology, Inc.

Project Manager:

Scott Jones
(919) 859-0669
sjones@agriwaste.com

Engineer:

Scott Jones
(919) 859-0669
sjones@agriwaste.com

Project: Whittaker Property
Property: 88 Brookview Court
Angier, NC 27501

Subdiv.: The Creek
Lot #: Lot 4

Owner: Robert Whittaker
Address: 88 Brookview Court
Angier, NC 27501

Phone: (401)-710-2054
Email: rwhittaker1@verizon.net

EHS:

Date:
10/22/2020

County:
Harnett

Permit #:

Type of System:
III b
New Construction
P.I.N. #:
0672-60-2805.000

Soil Parameters

Soil Evaluation By:

Jeff Vaughan

LTAR: gpd/ft^2

Special Conditions/Notes:

Repair system with 18" trench depth.

Design Parameters

Type of Establishment: Residence (less than 6 bedrooms)

Unit: Bedroom

of Units: 3

Septic Tank Specifications (if existing Septic Tank is replaced)

Min. Tank Capacity: 900 gal
Actual Tank Volume: gal
Tank Manufacturer: Shoaf
Tank Model: TS 1000 STB-347

	Exterior	Interior	
Length:	<input type="text" value="9.00"/>	<input type="text" value="8.50"/>	ft
Width:	<input type="text" value="4.83"/>	<input type="text" value="4.33"/>	ft
Depth:	<input type="text" value="5.63"/>		ft

Repair Drainfield Specifications

Type of Distribution: Parallel Press. Manifold

Trench Media: Chamber

Trench Width: ft

Trench Depth: in

(or as specified on permit)

Trench Bottom Area: ft^2

Minimum Drain Line: 400 ft

Actual Drain Line: ft

Number of Lines:

Minimum Line Spacing: ft O.C.

Wastewater Treatment System Design Calculations

Project: Whittaker Property
 Location: 88 Brookview Court
 Angier, NC 27501

Date: 10/22/2020
 County: Harnett

Septic Tank Sizing

Daily Flow Estimate:

Unit	# of Units	Flow/Unit	Flow/Day
Bedroom	3	120	360
			0
			0
			0
			0
			0

Q = gpd

Septic Tank Minimum Capacity: Per NCAC T15A:18A .1952(b)(1):

For individual residences with 3 or fewer bedrooms,

$$V = 900$$

Minimum Liquid Capacity (V) = gal

Septic Tank Specs:

Manufacturer: Shoaf

(if tank is replaced)

Model: TS 1000 STB-347

Volume: gal

Weight: lbs

Exterior
 Length: ft
 Width: ft
 Depth: ft

Interior
 ft
 ft

Shape of Risers: Circular

Diameter: ft

Drainfield Design

Project: Whittaker Property
Location: 88 Brookview Court
 Angier, NC 27501

Date: 10/22/2020
County: Harnett

Drainfield Sizing

LTAR:	0.3 gpd/ft ²	Type of Drainfield Media:	Chambers
Daily Design Flow:	360 gpd	Required Drainline After 25% Reduction:	<input type="text" value="300"/>
Drainfield Area:	1,200 ft ²	Minimum Line Spacing:	9 ft (O.C.)
Trench Width:	3 ft		
Required Drainline:	400 ft		

Drainfield Layout

Benchmark Description: Northeast Property Corner

Benchmark Elevation: 100 ft

Line	Use	Flag Color	Elevation (ft)	Layout Length (ft)	Utilized Primary Length (ft)	Utilized Repair Length (ft)
1	Layout Line	Red	101.3	110		85
2	Existing Line	Ex. Yellow	100.4	84		84
3	Existing Line	Ex. Pink	99.7	83		83
4	Existing Line	Ex. Purple	98.5	81		81
5	Layout Line	White	97.7	47		45
6	Layout Line	Blue	97.1	40		40
7	Layout Line	Red	95.9	38		35
8	Layout Line	White	95.0	31		30
Total:					<input type="text" value="0"/>	<input type="text" value="483"/>
Count:					<input type="text" value="0"/>	<input type="text" value="8"/>

24/b

CONVENTIONAL SEPTIC SYSTEM DESIGN (Repair)

Designed by: SJ
 Revised: 10/22/2020

Site Information

Project: Whittaker Property
 Site Address: 88 Brookview Court
 Angier, NC 27501
 County: Harnett

Design Information

Estimated Daily Flow: 360 gal/day
 L.T.A.R.: 0.3 gal/day/ft²
 L.T.A.R. + 5%: 0.315 gal/day/ft²
 Trench Width: 3 ft.
 Line Length Required: 400 ft.
 L.T.A.R. Reduced: 0.300 gal/day/ft²
 L.T.A.R. Reduced + 5%: 0.315 gal/day/ft²

DRAINFIELD INFO. - Repair

Proposed Type of System/Distribution: **Pump to Pressure Manifold using Chambers**

Line No.	Flag Color	Line Length (ft.)		Flow (gpm)	Flow/Foot (gpm/ft)	Line L.T.A.R.
1	Red	85	1/2in SCH 40	7.11	0.084	0.291
2	Ex. Yellow	84	1/2in SCH 80	5.48	0.065	0.227
3	Ex. Pink	83	1/2in SCH 80	5.48	0.066	0.230
4	Ex. Purple	81	1/2in SCH 80	5.48	0.068	0.235
5	White	85	1/2in SCH 80	5.48	0.064	0.224
6	Blue					
7	Red	65	1/2in SCH 80	5.48	0.084	0.293
8	White					
TOTAL		483		34.51		0.250

Total Run Time = 10.43 min.
 % of Dose Volume = 66.0% (Req. Range 66% - 75%)
 Dose Volume = 208.2 gal/dose
Run Time/Dose = 6.0 min (Range 5-7 min unless uphill, checked)
 Volume/depth = 21.07 gal/in (Dependent upon tank manufacturer, to be field verified)
 Estimated Drawdown = 10 in.

Manifold Box

Number of Taps = 6
 Manifold Length = 4.0 ft. (approximate)

PUMP DESIGN

System (initial/repair): **Repair**

Project: Whittaker Property
 Site Address: 88 Brookview Court
 Angier, NC 27501
 County: Harnett

Friction Losses

Suction Head =	0 ft.	(submersible = 0)
Elev. Difference (highest point from pump) =	10.00 ft.	
Design Pressure At Outlet =	2 ft.	
Supply Line - 2.5" Schedule 40 PVC		
Pipe Diameter (ID) =	2.445 in.	Flow = 34.51 gpm
Pipe Length =	150 ft.	Velocity = 2.36 ft/sec
Pipe Length for Fittings =	15 ft.	
Est. Friction Loss per 100' =	0.89 ft/100 ft.	
Estimated Friction Loss =	1.48 ft.	
Pressure Filter Friction Loss =	1.16 ft.	(from manufacturer)
Friction Loss - Taps/Special Fittings =	3.5 ft.	
TOTAL = 18.13 ft.		

Pump Efficiency = 0.7 (assumed, typical)
 Motor Efficiency = 0.9 (assumed for electric pumps)
Flow = 34.51 gpm

Required Horsepower = 0.25 hp
TDH = 18.13 ft.

Pump Selection

Manufacturer: Zoeller
Model: N152
Horsepower: 2/5

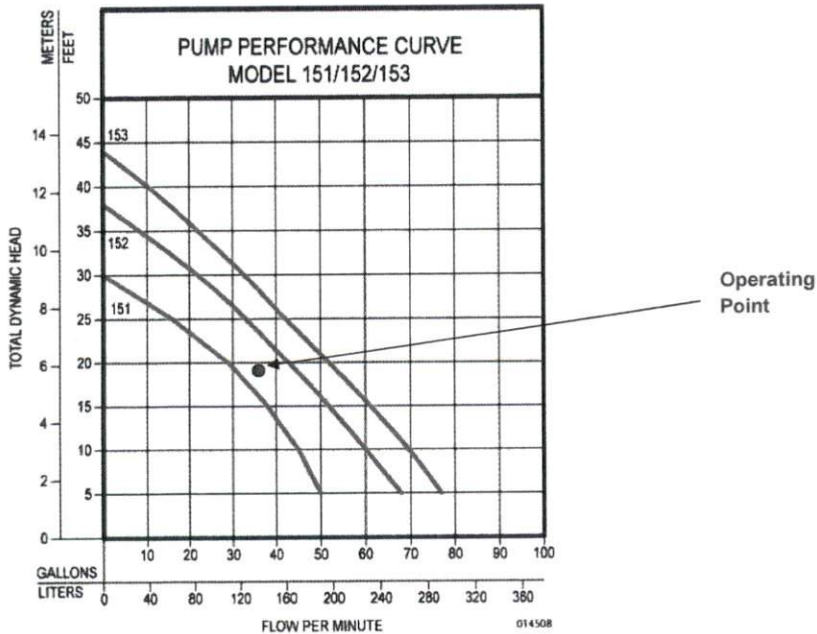

11/42

PUMP TANK STORAGE (if tank is replaced)

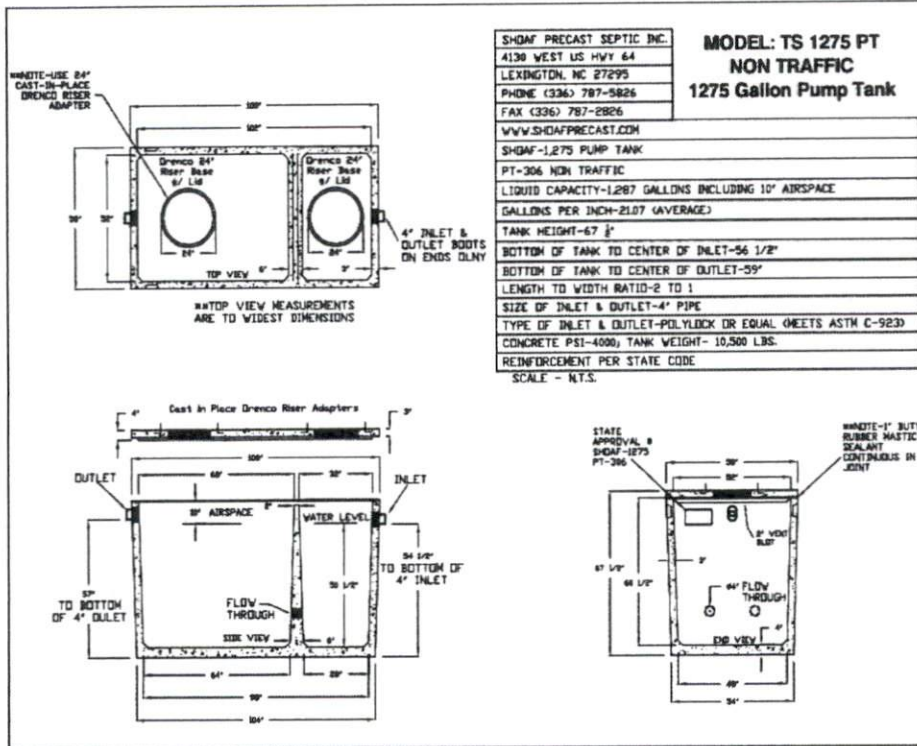

Interior Height (in.) 60.5
 Avg. Gals/Inch 21.07

Primary & Repair System

Elevations, measured from bottom towards top (0 = Interior Bottom of Tank):

Top of pump (including 4" block)	16.0 in.	(Pump approx. 12" tall)
Pump Off	18.0 in.	
Pump On	28.0 in.	(set for dose volume)
Alarm on	34.0 in.	(6" above ON Float)

Emergency Storage Available

Pump Tank	558.4 gal	(HWA to Tank Ceiling)
Days of Storage	1.55 days	

(determined from interior top of tank - "High Water Alarm")

12/42

Septic Tank Buoyancy

Project: Whittaker Property
Location: 88 Brookview Court
Angier, NC 27501

Date: 10/22/2020
County: Harnett

Properties/Assumptions

Tank Size: 1,000 gal
Effluent Density: 62.4 lb/ft³ (Specific Weight of Water)
Soil Cover Over Tank: 1 ft
Soil Bulk Density: 1.25
Groundwater Height: -1 ft
(in relation to top of the tank)

Tank Dimensions

	Exterior	Interior
Length:	9.00 ft	8.50 ft
Width:	4.83 ft	4.33 ft
Depth:	5.63 ft	
Effective Depth:	4.63 ft	(accounting for the groundwater height)
Permanent Liquid Depth in Tank:	0 ft	
Area of Riser Openings:	6.28 ft ²	
Estimated Tank Weight:	10,500 lb	(from manufacturer)

Buoyancy Force Calculation

Buoyancy Force = Specific Weight of Water * Displaced Volume
Buoyancy Force = 12,554 lb

Weight Calculation

Tank Weight: 10,500 lb
Water Weight in Tank: 0 lb
Soil Weight Over Tank: 2,903 lb
Total Weight: 13,403 lb

Result

The total weight must be greater than the buoyancy force so that tank will not float during high water table conditions.

Since the total weight is greater than the buoyancy force, the tank will not float and is suitable for use.

Contact Engineer if soil wetness conditions are found within 2' of existing grade at tank burial location

Pump Tank Buoyancy

Project: Whittaker Property
Location: 88 Brookview Court
Angier, NC 27501

Date: 10/22/2020
County: Harnett

Properties/Assumptions

Tank Size: 1,275 gal
Effluent Density: 62.4 lb/ft³ (Specific Weight of Water)
Soil Cover Over Tank: 1 ft
Soil Bulk Density: 1.25
Groundwater Height: -1 ft
(in relation to top of the tank)

Tank Dimensions

	Exterior	Interior
Length:	9.00 ft	8.50 ft
Width:	4.83 ft	4.33 ft
Depth:	5.63 ft	
Effective Depth:	4.63 ft	(accounting for the groundwater height)
Permanent Liquid Depth in Tank:	0 ft	
Area of Riser Openings:	3.14 ft ²	
Estimated Tank Weight:	10,500 lb	(from manufacturer)

Buoyancy Force Calculation

Buoyancy Force = Specific Weight of Water * Displaced Volume

Buoyancy Force = 12,554 lb

Weight Calculation

Tank Weight: 10,500 lb
Water Weight in Tank: 0 lb
Soil Weight Over Tank: 3,148 lb
Total Weight: 13,648 lb

Result

The total weight must be greater than the buoyancy force so that tank will not float during high water table conditions.

Since the total weight is greater than the buoyancy force, the tank will not float and is suitable for use.

Contact Engineer if soil wetness conditions are found within 2' of existing grade at tank burial location

14/42

Whittaker Property Repair WWTS

Project Location: Lot 4 – The Creek
 88 Brookview Court
 Angier, NC 27501
 Harnett County
 PIN: 0672-60-2805.000

Project Owner: Robert Whittaker
 88 Brookview Court
 Angier, NC 27501
 (401) 710 – 2054
 rwhittaker1@verizon.net

Project Consultant: Jeff Vaughan, L.S.S.
 javaughan@agriwaste.com
 Scott Jones, P.E.
 sjones@agriwaste.com

Agri-Waste Technology, Inc.
 501 N. Salem Street, Suite 203
 Apex, NC 27502
 (919) 859-0669
 (919) 233-1970 Fax

System Overview: Single Family Residence – Repair
 Three (3) Bedroom, 360 gpd
 Pressure Manifold with Chambers

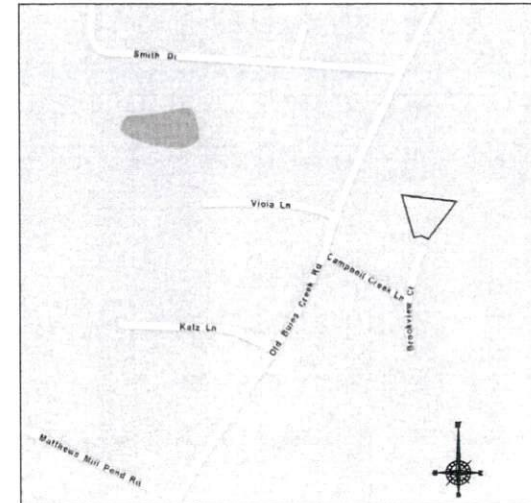

NTS

VICINITY MAP

Sheet Index

Sheet 1	Cover Sheet
Sheet 2	Property Layout
Sheet 3	Component Layout
Sheet 4	Repair Drainfield
Sheet 5	Detail Sheet 1
Sheet 6	Detail Sheet 2
Sheet 7	Excavation Safety

AWT
 Engineers and Soil Scientists
 Agri-Waste Technology, Inc.
 501 N. Salem Street, Suite 203
 Apex, North Carolina 27502
 919-859-0669
 www.agriwaste.com

Whittaker Property
 Repair WWTS

Owner Information:
 Robert Whittaker
 88 Brookview Court
 Angier, NC 27501
 (401) 710-2054
 rwhittaker1@verizon.net

Property Information:
 88 Brookview Court
 Lot 4 – The Creek
 Angier, NC 27501
 Harnett County
 PIN: 0672-60-2805.000

This document originally
 issued and sealed by
 Scott P. Jones,
 N.C. PE #045605,
 on November 18, 2020.
 This medium shall not be
 considered a certified
 document.

FINAL DESIGN
 NOT RELEASED FOR CONSTRUCTION

REV. ISSUED DATE DESCRIPTION

SHEET TITLE

Cover Sheet

DRAWN BY: S. Jones
 CREATED ON: 10/30/2020

REVISED BY: REVISED ON:

RELEASED BY: RELEASED ON:

SHEET NAME:

WW-1



15/172