

STARBUCKS #59763  
HWY 24 & BRINKLEY HILL  
2778 NC-24  
CAMERON, NC 28326



19-46185

***HILTONDISPLAYS***

125 HILLSIDE DRIVE • GREENVILLE SC 29607

P 800 353 9132 • F 864 242 2204

[www.hiltondisplays.com](http://www.hiltondisplays.com)

# SITE PLAN

- A** 18" CHANNEL LETTERS
- B** 48" SIREN
- C** 36" SIREN
- D** 48" DRIVE THRU CABINET-RH
- E** 36" DT DIRECTIONAL
- F** 36" TY/EO DIRECTIONAL
- G** MOP SIGN / 4' EXTENSION KIT
- H** PARKING SIGNS
- I** CLEARANCE BAR
- J** PRE-MENU BOARD
- K** DOS ON CANOPY / DCB
- L** 5 PANEL MENU BOARD
- M** MONUMENT
- N** PARKING SIGNS / 10 MIN

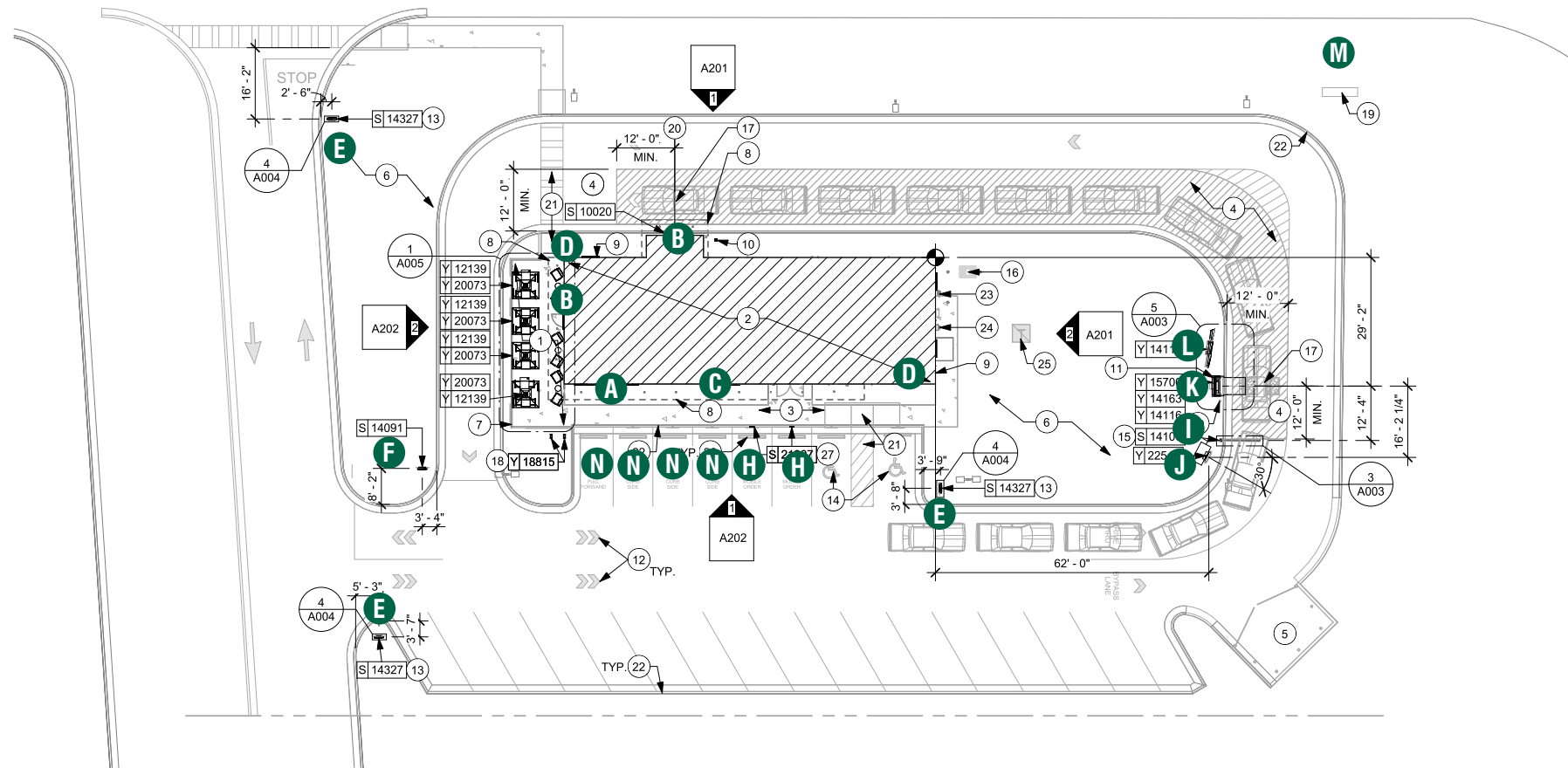

1 1ST FLOOR - SITE PLAN

**QID 19-46185**

**JOB NAME**

Starbucks 59763

**LOCATION**

2778 NC-24  
CAMERON, NC 28326

**CUSTOMER CONTACT**

**SALESMAN / PM**

Stasia Rohn

**DESIGNER**

Chad Wike

**DWG. DATE**

9-23-21

**REV. DATE / REVISION**

1-19-22 CW

3-18-22 CW

3-31-22 CW

**SCALE**

As Noted

**FILE**

2021/Starbucks/Locations/  
Cameron NC/19-46185/  
SB Cameron NC 19-46185 BB

**DESIGN SPECIFICATIONS ACCEPTED BY:**

EST: CLIENT:

SLS/PM: LANDLORD:

THE INTENT OF THIS DRAWING IS TO SHOW A CONCEPTUAL REPRESENTATION OF THE PROPOSED SIGNAGE. DUE TO VARIATIONS IN PRINTING DEVICES AND SUBSTRATES, THE FINISHED PRODUCT MAY DIFFER SLIGHTLY FROM DRAWING.



**ELEVATION**

- A** 18" CHANNEL LETTERS
- B** 48" SIREN
- C** 36" SIREN
- D** 48" DRIVE THRU CABINET-RH
- E** 36" DT DIRECTIONAL
- F** 36" TY/EO DIRECTIONAL
- G** MOP SIGN / 4' EXTENSION KIT
- H** PARKING SIGNS
- I** CLEARANCE BAR
- J** PRE-MENU BOARD
- K** DOS ON CANOPY / DCB
- L** 5 PANEL MENU BOARD
- M** MONUMENT
- N** PARKING SIGNS / 10 MIN

**HILTONDISPLAYS**  
 125 HILLSIDE DRIVE • GREENVILLE SC 29607  
 P 800 353 9132 • F 864 242 2204  
 www.hiltondisplays.com

**QID 19-46185**

**JOB NAME**

Starbucks 59763

**LOCATION**

2778 NC-24  
 CAMERON, NC 28326

**CUSTOMER CONTACT**

**SALESMAN / PM**

Stasia Rohn

**DESIGNER**

Chad Wike

**DWG. DATE**

9-23-21

**REV. DATE / REVISION**

1-19-22 CW

3-18-22 CW

3-31-22 CW

**SCALE**

As Noted

**FILE**

2021/Starbucks/Locations/  
 Cameron NC/19-46185/  
 SB Cameron NC 19-46185 BB

**DESIGN SPECIFICATIONS ACCEPTED BY:**

EST:	CLIENT:
SLS/PM:	LANDLORD:

THE INTENT OF THIS DRAWING IS TO SHOW A CONCEPTUAL REPRESENTATION OF THE PROPOSED SIGNAGE. DUE TO VARIATIONS IN PRINTING DEVICES AND SUBSTRATES, THE FINISHED PRODUCT MAY DIFFER SLIGHTLY FROM DRAWING.

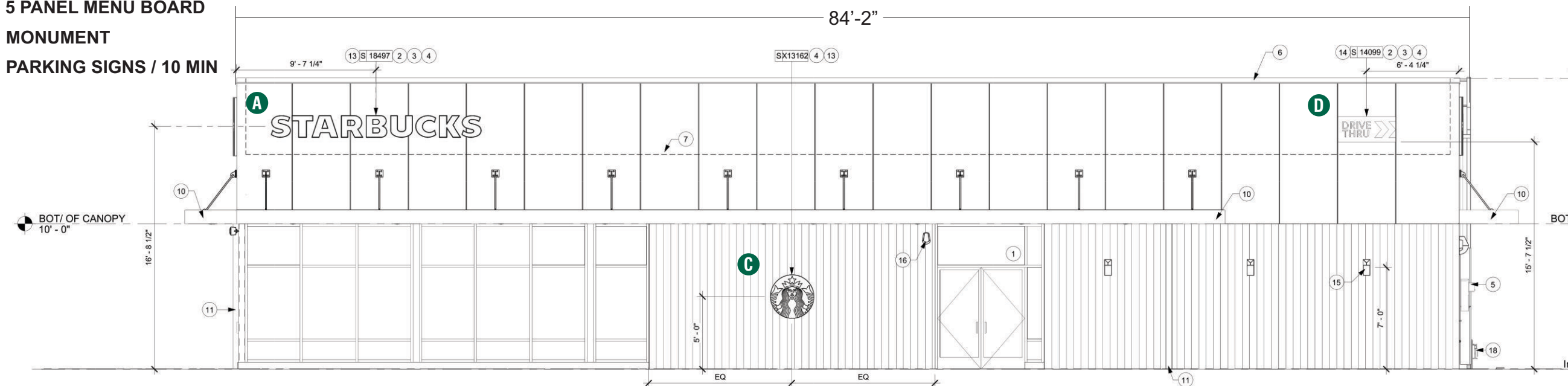

**1 SOUTH ELEVATION**  
 Scale: 1/8" = 1'-0"

**ELEVATION**

- A** 18" CHANNEL LETTERS
- B** 48" SIREN
- C** 36" SIREN
- D** 48" DRIVE THRU CABINET-RH
- E** 36" DT DIRECTIONAL
- F** 36" TY/EO DIRECTIONAL
- G** MOP SIGN / 4' EXTENSION KIT
- H** PARKING SIGNS
- I** CLEARANCE BAR
- J** PRE-MENU BOARD
- K** DOS ON CANOPY / DCB
- L** 5 PANEL MENU BOARD
- M** MONUMENT
- N** PARKING SIGNS / 10 MIN

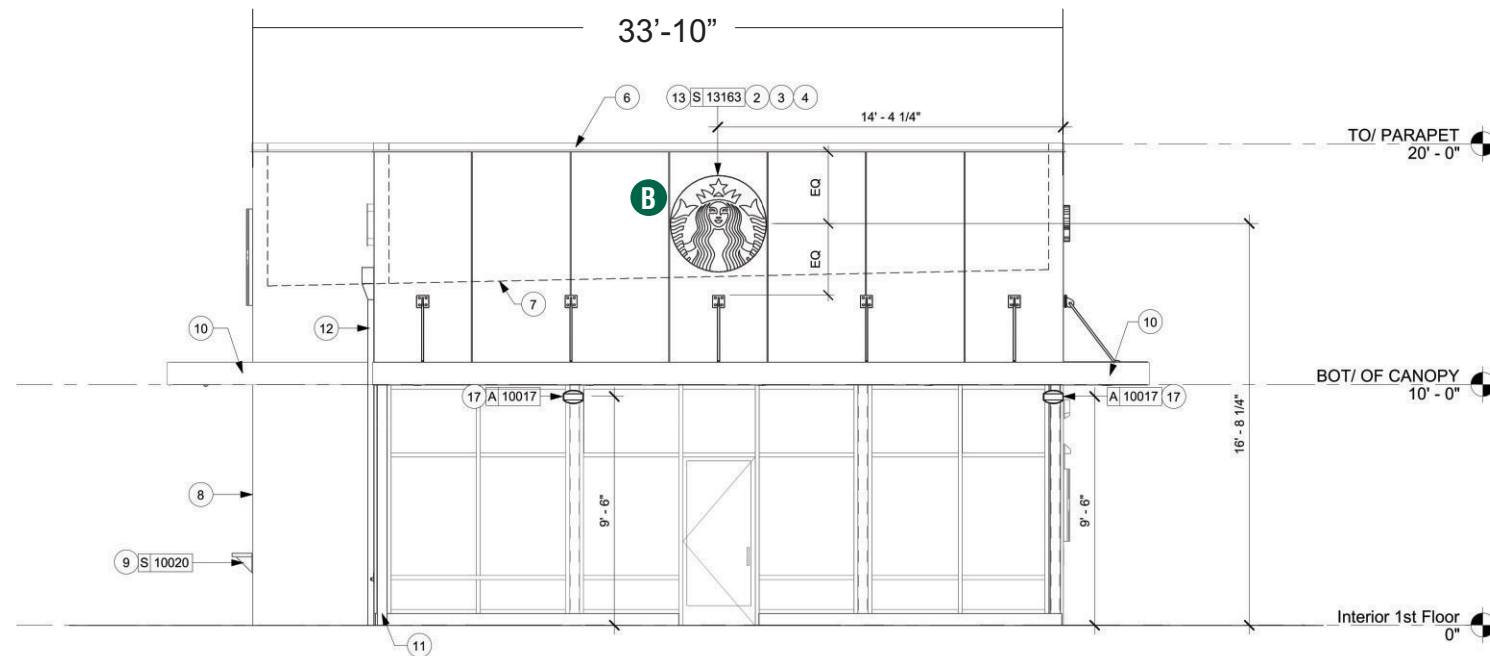

**2 WEST ELEVATION**  
Scale: 1/8" = 1'-0"

**QID 19-46185**

**JOB NAME**

Starbucks 59763

**LOCATION**

2778 NC-24  
CAMERON, NC 28326

**CUSTOMER CONTACT**

**SALESMAN / PM**

Stasia Rohn

**DESIGNER**

Chad Wike

**DWG. DATE**

9-23-21

**REV. DATE / REVISION**

1-19-22 CW

3-18-22 CW

3-31-22 CW

**SCALE**

As Noted

**FILE**

2021/Starbucks/Locations/  
Cameron NC/19-46185/  
SB Cameron NC 19-46185 BB

**DESIGN SPECIFICATIONS ACCEPTED BY:**

EST:	CLIENT:
SLS/PM:	LANDLORD:

THE INTENT OF THIS DRAWING IS TO SHOW A CONCEPTUAL REPRESENTATION OF THE PROPOSED SIGNAGE. DUE TO VARIATIONS IN PRINTING DEVICES AND SUBSTRATES, THE FINISHED PRODUCT MAY DIFFER SLIGHTLY FROM DRAWING.



# ELEVATION

- A** 18" CHANNEL LETTERS
- B** 48" SIREN
- C** 36" SIREN
- D** 48" DRIVE THRU CABINET-RH
- E** 36" DT DIRECTIONAL
- F** 36" TY/EO DIRECTIONAL
- G** MOP SIGN / 4' EXTENSION KIT
- H** PARKING SIGNS
- I** CLEARANCE BAR
- J** PRE-MENU BOARD
- K** DOS ON CANOPY / DCB
- L** 5 PANEL MENU BOARD
- M** MONUMENT
- N** PARKING SIGNS / 10 MIN

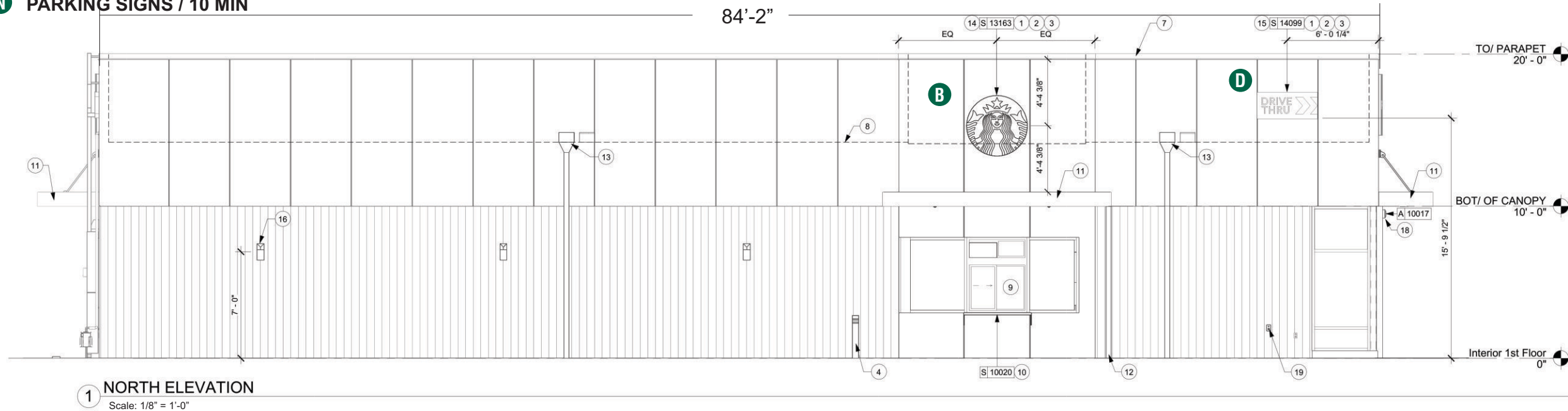

**1 NORTH ELEVATION**  
Scale: 1/8" = 1'-0"

**QID 19-46185**

**JOB NAME**

Starbucks 59763

**LOCATION**

2778 NC-24  
CAMERON, NC 28326

**CUSTOMER CONTACT**

**SALESMAN / PM**

Stasia Rohn

**DESIGNER**

Chad Wike

**DWG. DATE**

9-23-21

**REV. DATE / REVISION**

1-19-22 CW

3-18-22 CW

3-31-22 CW

**SCALE**

As Noted

**FILE**

2021/Starbucks/Locations/  
Cameron NC/19-46185/  
SB Cameron NC 19-46185 BB

**DESIGN SPECIFICATIONS ACCEPTED BY:**

EST:	CLIENT:
SLS/PM:	LANDLORD:

THE INTENT OF THIS DRAWING IS TO SHOW A CONCEPTUAL REPRESENTATION OF THE PROPOSED SIGNAGE. DUE TO VARIATIONS IN PRINTING DEVICES AND SUBSTRATES, THE FINISHED PRODUCT MAY DIFFER SLIGHTLY FROM DRAWING.



# ELEVATION

- A** 18" CHANNEL LETTERS
- B** 48" SIREN
- C** 36" SIREN
- D** 48" DRIVE THRU CABINET-RH
- E** 36" DT DIRECTIONAL
- F** 36" TY/EO DIRECTIONAL
- G** MOP SIGN / 4' EXTENSION KIT
- H** PARKING SIGNS
- I** CLEARANCE BAR
- J** PRE-MENU BOARD
- K** DOS ON CANOPY / DCB
- L** 5 PANEL MENU BOARD
- M** MONUMENT
- N** PARKING SIGNS / 10 MIN

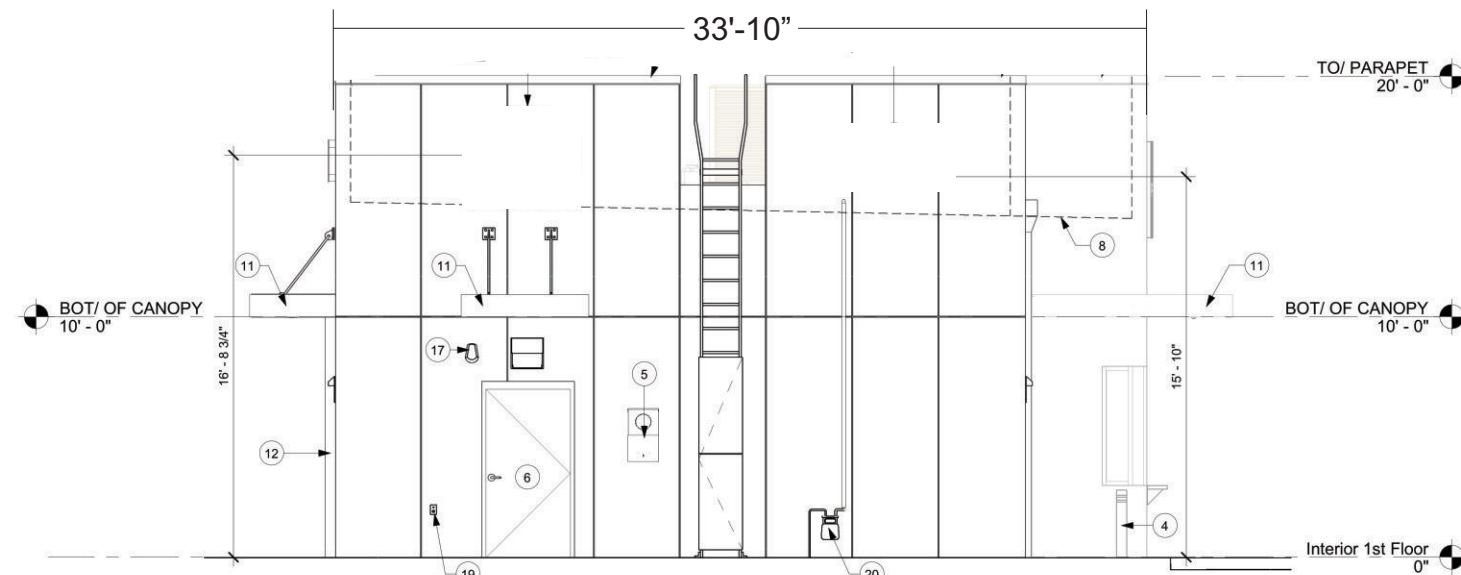

**2 EAST ELEVATION**  
Scale: 1/8" = 1'-0"

**HILTONDISPLAYS**  
125 HILLSIDE DRIVE • GREENVILLE SC 29607  
P 800 353 9132 • F 864 242 2204  
www.hiltondisplays.com

**QID 19-46185**

**JOB NAME**

Starbucks 59763

**LOCATION**

2778 NC-24  
CAMERON, NC 28326

**CUSTOMER CONTACT**

**SALESMAN / PM**

Stasia Rohn

**DESIGNER**

Chad Wike

**DWG. DATE**

9-23-21

**REV. DATE / REVISION**

1-19-22 CW

3-18-22 CW

3-31-22 CW

**SCALE**

As Noted

**FILE**

2021/Starbucks/Locations/  
Cameron NC/19-46185/  
SB Cameron NC 19-46185 BB

**DESIGN SPECIFICATIONS ACCEPTED BY:**

EST:	CLIENT:
SLS/PM:	LANDLORD:

THE INTENT OF THIS DRAWING IS TO SHOW A CONCEPTUAL REPRESENTATION OF THE PROPOSED SIGNAGE. DUE TO VARIATIONS IN PRINTING DEVICES AND SUBSTRATES, THE FINISHED PRODUCT MAY DIFFER SLIGHTLY FROM DRAWING.



**ELEVATION**

- A** 18" CHANNEL LETTERS
- B** 48" SIREN
- C** 36" SIREN
- D** 48" DRIVE THRU CABINET-RH
- E** 36" DT DIRECTIONAL
- F** 36" TY/EO DIRECTIONAL
- G** MOP SIGN / 4' EXTENSION KIT
- H** PARKING SIGNS
- I** CLEARANCE BAR
- J** PRE-MENU BOARD
- K** DOS ON CANOPY / DCB
- L** 5 PANEL MENU BOARD
- M** MONUMENT
- N** PARKING SIGNS / 10 MIN

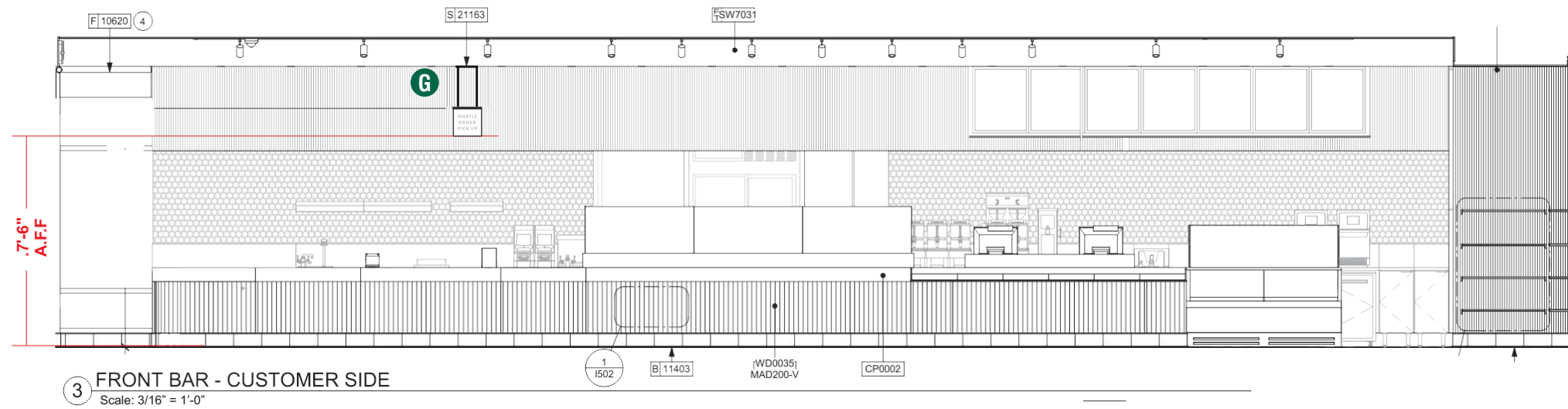

**QID 19-46185**

**JOB NAME**

Starbucks 59763

**LOCATION**

2778 NC-24  
CAMERON, NC 28326

**CUSTOMER CONTACT**

**SALESMAN / PM**

Stasia Rohn

**DESIGNER**

Chad Wike

**DWG. DATE**

9-23-21

**REV. DATE / REVISION**

1-19-22 CW

3-18-22 CW

3-31-22 CW

**SCALE**

As Noted

**FILE**

2021/Starbucks/Locations/  
Cameron NC/19-46185/  
SB Cameron NC 19-46185 BB

**DESIGN SPECIFICATIONS ACCEPTED BY:**

EST:	CLIENT:
SLS/PM:	LANDLORD:

THE INTENT OF THIS DRAWING IS TO SHOW A CONCEPTUAL REPRESENTATION OF THE PROPOSED SIGNAGE. DUE TO VARIATIONS IN PRINTING DEVICES AND SUBSTRATES, THE FINISHED PRODUCT MAY DIFFER SLIGHTLY FROM DRAWING.



# 18" CHANNEL LETTERS - REMOTE

SBC-S18497-SB-W-SL

Qty 1

**A**

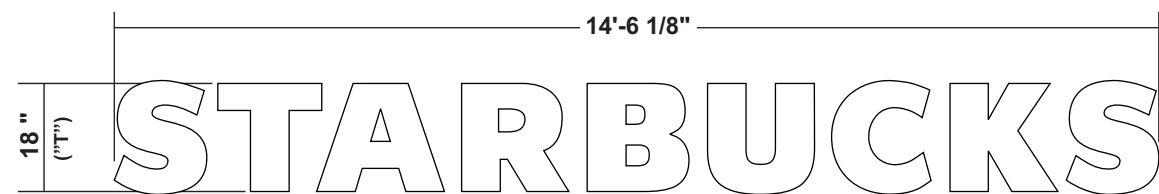

**1** Front View  
Scale: 3/8" = 1' (11x17 Paper)

**22.94 SF**



**2** Side View

## SPECIFICATIONS

- A** Internally illuminated channel letters to be fabricated from .040 returns aluminum with pre-painted White interiors and pre-finished Black returns. Letter backs to be aluminum stapled to sidewalls and sealed.
- B** Faces to be 3/16" White acrylic with 1" Black trimcap
- C** Letters illuminated w/ Sloan Prism Enlighten White 6500k LED's w/ remote power supply.
- D** Letters to be installed flush to wall.

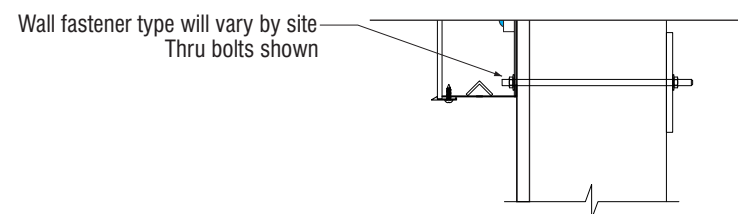
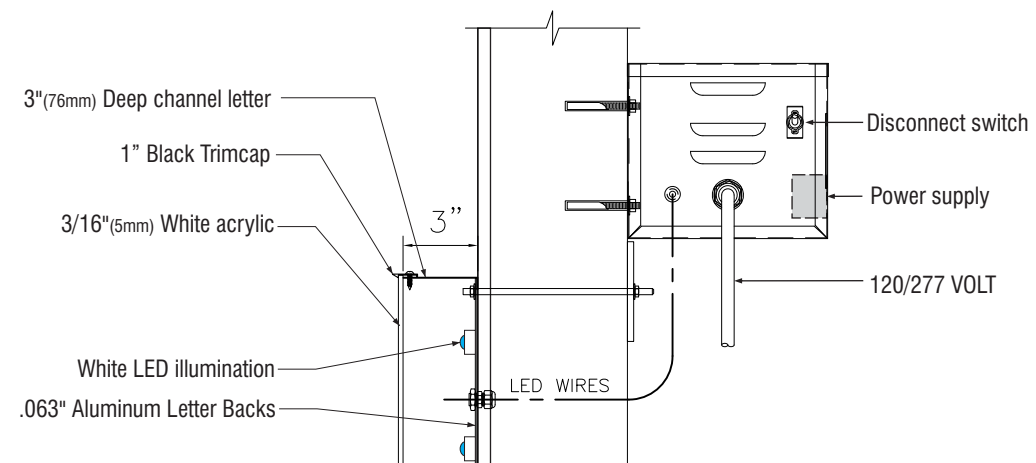

MOUNTING AND LETTER DETAIL(TYP)  
SCALE: NTS

COLOR LEGEND		
	PMS/PAINT	VINYL
	PMS 3425 C	3M 3630-76
	RAL 7021M	3M 3630-22
	PMS WHITE	3M 3630-20/ 7725-10 TRANSLUCENT OPAQUE
	PMS 369 C	NA
	REFL. WHITE	3M 680-10

**HILTONDISPLAYS**

125 HILLSIDE DRIVE • GREENVILLE SC 29607  
P 800 353 9132 • F 864 242 2204  
www.hiltondisplays.com

**QID 19-46185**

**JOB NAME**

Starbucks 59763

**LOCATION**

2778 NC-24  
CAMERON, NC 28326

**CUSTOMER CONTACT**

**SALESMAN / PM**

Stasia Rohn

**DESIGNER**

Chad Wike

**DWG. DATE**

9-23-21

**REV. DATE / REVISION**

1-19-22 CW

3-18-22 CW

3-31-22 CW

**SCALE**

As Noted

**FILE**

2021/Starbucks/Locations/  
Cameron NC/19-46185/  
SB Cameron NC 19-46185 BB

**DESIGN SPECIFICATIONS ACCEPTED BY:**

EST: CLIENT:

SLS/PM: LANDLORD:

THE INTENT OF THIS DRAWING IS TO SHOW A CONCEPTUAL REPRESENTATION OF THE PROPOSED SIGNAGE. DUE TO VARIATIONS IN PRINTING DEVICES AND SUBSTRATES, THE FINISHED PRODUCT MAY DIFFER SLIGHTLY FROM DRAWING.





# 48" ILLUMINATED SIREN

Qty 2

SBC-S13163-SL

**B**



## 1 Front View

Scale: 3/4" = 1'-0" (11X17 Paper)

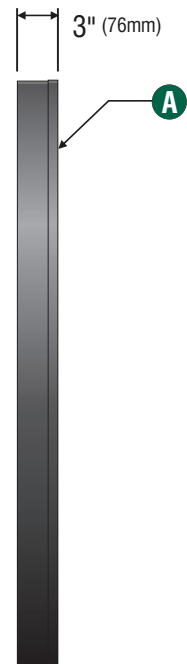

## 2 Side view

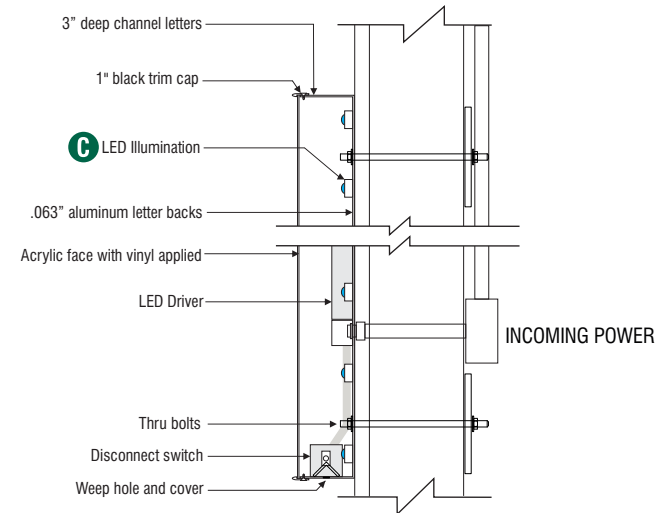

## 3 Disk Section View Typ.

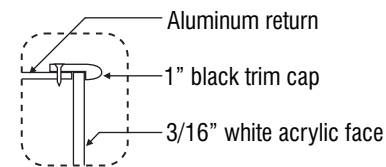

## 4 Enlarged Detail

### SPECIFICATIONS:

- A** Single faced internally illuminated wall mount logo disk. Cabinet to be 3" deep, fabricated aluminum returns and back. Paint cabinet black. Faces to be 3/16" white Plex with 1" black trimcap
- B** Graphics of logo to be 1st surface 3M Translucent Scotchcal vinyl- Holly Green #3630-76. Siren to show thru White.
- C** Internally illuminated logo disk with Sloan Prism Enlighten 6500K white LED's

COLOR LEGEND		
	PMS/PAINT	VINYL
	PMS 3425 C	3M 3630-76
	RAL 7021M	3M 3630-22
	PMS WHITE	3M 3630-20/ 7725-10 TRANSLUCENT OPAQUE
	PMS 369 C	NA
	REFL. WHITE	3M 680-10

wall mount EVOLVED			
Size	Sq.Ft.	Sq.M.	Volts
48" (1219.2mm)	12.56	1.17	120/277

**HILTONDISPLAYS**  
 125 HILLSIDE DRIVE • GREENVILLE SC 29607  
 P 800 353 9132 • F 864 242 2204  
 www.hiltondisplays.com

**QID 19-46185**

**JOB NAME**

Starbucks 59763

**LOCATION**

2778 NC-24  
CAMERON, NC 28326

**CUSTOMER CONTACT**

**SALESMAN / PM**

Stasia Rohn

**DESIGNER**

Chad Wike

**DWG. DATE**

9-23-21

**REV. DATE / REVISION**

1-19-22 CW

3-18-22 CW

3-31-22 CW

**SCALE**

As Noted

**FILE**

2021/Starbucks/Locations/  
Cameron NC/19-46185/  
SB Cameron NC 19-46185 BB

**DESIGN SPECIFICATIONS ACCEPTED BY:**

EST:	CLIENT:
SLS/PM:	LANDLORD:

THE INTENT OF THIS DRAWING IS TO SHOW A CONCEPTUAL REPRESENTATION OF THE PROPOSED SIGNAGE. DUE TO VARIATIONS IN PRINTING DEVICES AND SUBSTRATES, THE FINISHED PRODUCT MAY DIFFER SLIGHTLY FROM DRAWING.



# 36" NON ILLUMINATED SIREN

Qty 1

SBC-19-46185-3

C

**HILTONDISPLAYS**

125 HILLSIDE DRIVE • GREENVILLE SC 29607  
P 800 353 9132 • F 864 242 2204  
www.hiltondisplays.com

**QID 19-46185**

**JOB NAME**

Starbucks 59763

**LOCATION**

2778 NC-24  
CAMERON, NC 28326

**CUSTOMER CONTACT**

**SALESMAN / PM**

Stasia Rohn

**DESIGNER**

Chad Wike

**DWG. DATE**

9-23-21

**REV. DATE / REVISION**

1-19-22 CW

3-18-22 CW

3-31-22 CW

**SCALE**

As Noted

**FILE**

2021/Starbucks/Locations/  
Cameron NC/19-46185/  
SB Cameron NC 19-46185 BB

**DESIGN SPECIFICATIONS ACCEPTED BY:**

EST:	CLIENT:
SLS/PM:	LANDLORD:

THE INTENT OF THIS DRAWING IS TO SHOW A CONCEPTUAL REPRESENTATION OF THE PROPOSED SIGNAGE. DUE TO VARIATIONS IN PRINTING DEVICES AND SUBSTRATES, THE FINISHED PRODUCT MAY DIFFER SLIGHTLY FROM DRAWING.

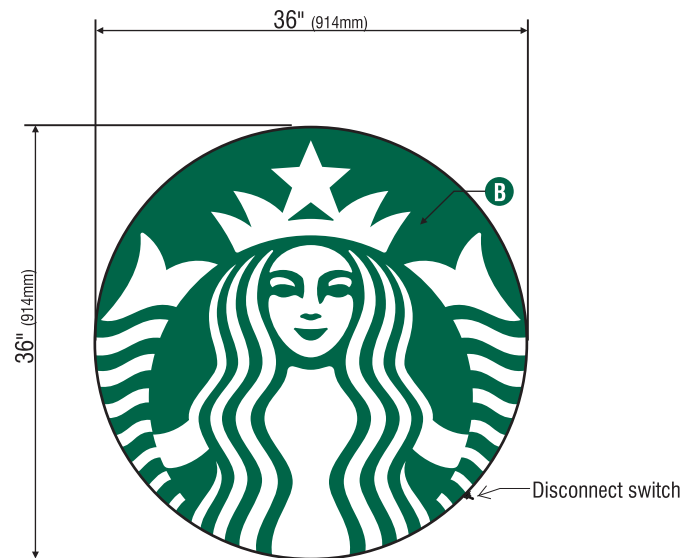

1 Front View

3/4" = 1' (11x17 Paper)

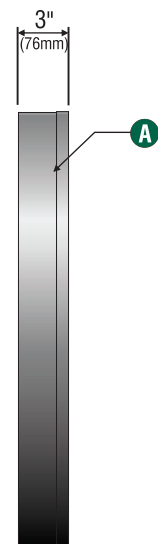

2 Side View

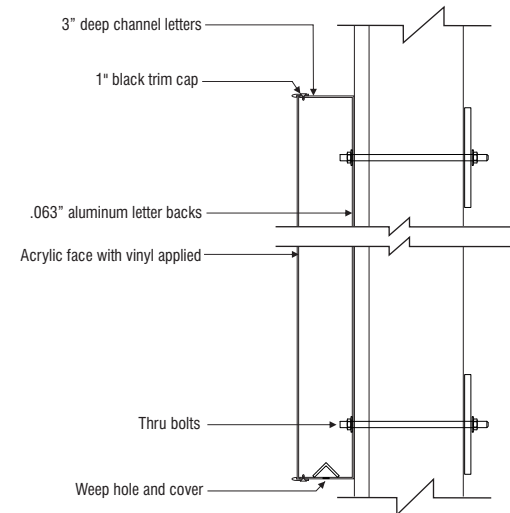

3 Disk Section View Typ.

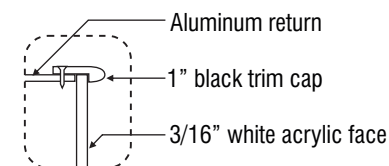

4 Enlarged Detail

**SPECIFICATIONS:**

- A** Single faced Non illuminated wall mount logo disk. Cabinet to be 3" deep, fabricated aluminum returns and back. Paint cabinet black. Faces to be 3/16" white Plex with 1" black trimcap
- B** Graphics of logo to be 1st surface 3M Translucent Scotchcal vinyl- Holly Green #3630-76. Siren to show thru White.

COLOR LEGEND		
	PMS/PAINT	VINYL
	PMS 3425 C	3M 3630-76
	RAL 7021M	3M 3630-22
	PMS WHITE	3M 3630-20/ 7725-10 TRANSLUCENT OPAQUE
	PMS 369 C	NA
	REFL. WHITE	3M 680-10

wall mount EVOLVED		
Size	Sq.Ft.	Sq.M.
36"	7.07	0.66

# 48" DT WALL SIGN-RH

Qty 2

SBC-S14099-SL

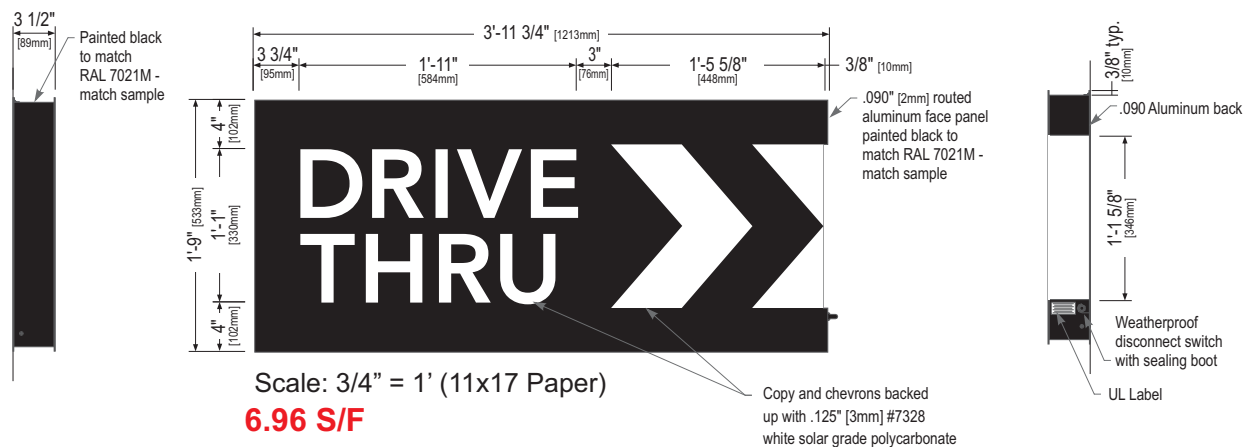

Left Side View

Front Elevation View

Right Side View

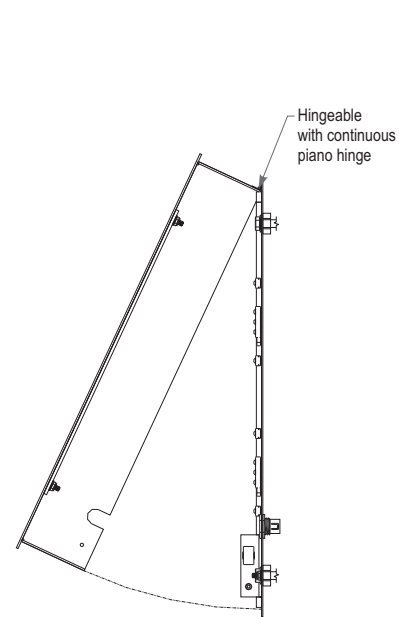

Service Position View  
NOT TO SCALE

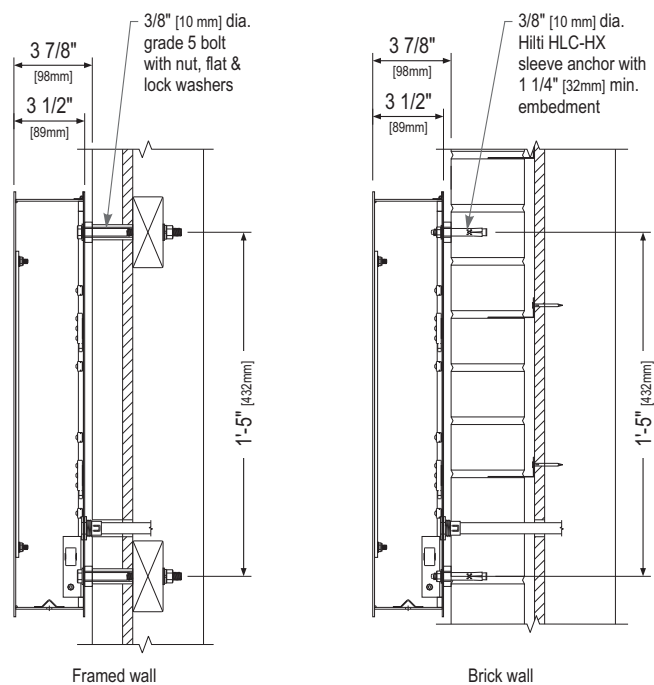

Section View at Installation Detail  
NOT TO SCALE

COLOR LEGEND		
	PMS/PAINT	VINYL
	PMS 3425 C	3M 3630-76
	RAL 7021M	3M 3630-22
	PMS WHITE	3M 3630-20/ 7725-10 TRANSLUCENT OPAQUE
	PMS 369 C	NA
	REFL. WHITE	3M 680-10

## Sign Specifications:

### Cabinet:

- Fabricated .090" [2mm] aluminum housing painted black to match RAL 7021M with 3M #180-10 white vinyl end cap as shown.
- Directional copy and chevrons backed up with .125" white polycarb. All polycarb face elements to be attached to aluminum face panel with weld studs.
- Welded aluminum construction with no visible fasteners. Fasteners retaining the hinged face will be located on the bottom such that they are not visible. All fasteners used in the assembly of internal components shall be coated to prevent corrosion.
- Internal structure of cabinet shall be per approved shop drawings.
- Graphic elements are internally illuminated using Sloan Prism Enlighten LEDs. LED's to be mounted on back panel with self-contained power supply. All electrical components are removable for service.

### Regulatory:

- Sign must meet all regulations in the National Electric Code as well as any local or state electrical codes.
- As per NEC 600.6, sign is equipped with a service disconnect switch.
- Sign must be listed as an Electric Sign per Underwriters Laboratories UL48 and/or CSA and bear the appropriate UL, CUL or CSA relevant certification marks. Primary power by electrical contractor per NEC.

Size	Sq. Ft. <sup>1</sup>	Sq. Ft. <sup>2</sup>	Volts	Amps
21"	4.52	6.96	120/277	0.85

1: Figured as illuminated center part  
 2: Figured as complete signage

**HILTONDISPLAYS**

125 HILLSIDE DRIVE • GREENVILLE SC 29607  
 P 800 353 9132 • F 864 242 2204  
 www.hiltondisplays.com

**QID 19-46185**

JOB NAME

Starbucks 59763

LOCATION

2778 NC-24  
 CAMERON, NC 28326

CUSTOMER CONTACT

SALESMAN / PM

Stasia Rohn

DESIGNER

Chad Wike

DWG. DATE

9-23-21

REV. DATE / REVISION

1-19-22 CW

3-18-22 CW

3-31-22 CW

SCALE

As Noted

FILE

2021/Starbucks/Locations/  
 Cameron NC/19-46185/  
 SB Cameron NC 19-46185 BB

DESIGN SPECIFICATIONS ACCEPTED BY:

EST: CLIENT:

SLS/PM: LANDLORD:

THE INTENT OF THIS DRAWING IS TO SHOW A CONCEPTUAL REPRESENTATION OF THE PROPOSED SIGNAGE. DUE TO VARIATIONS IN PRINTING DEVICES AND SUBSTRATES, THE FINISHED PRODUCT MAY DIFFER SLIGHTLY FROM DRAWING.



# 36" ILLUMINATED DIRECTIONAL <DT / DT>

Qty 3

SBC-AD3624-DT-SL

**E**

halo-lit logo is first surface vinyl film to match PMS 3425 on 3/8" clear polycarb for push-thru

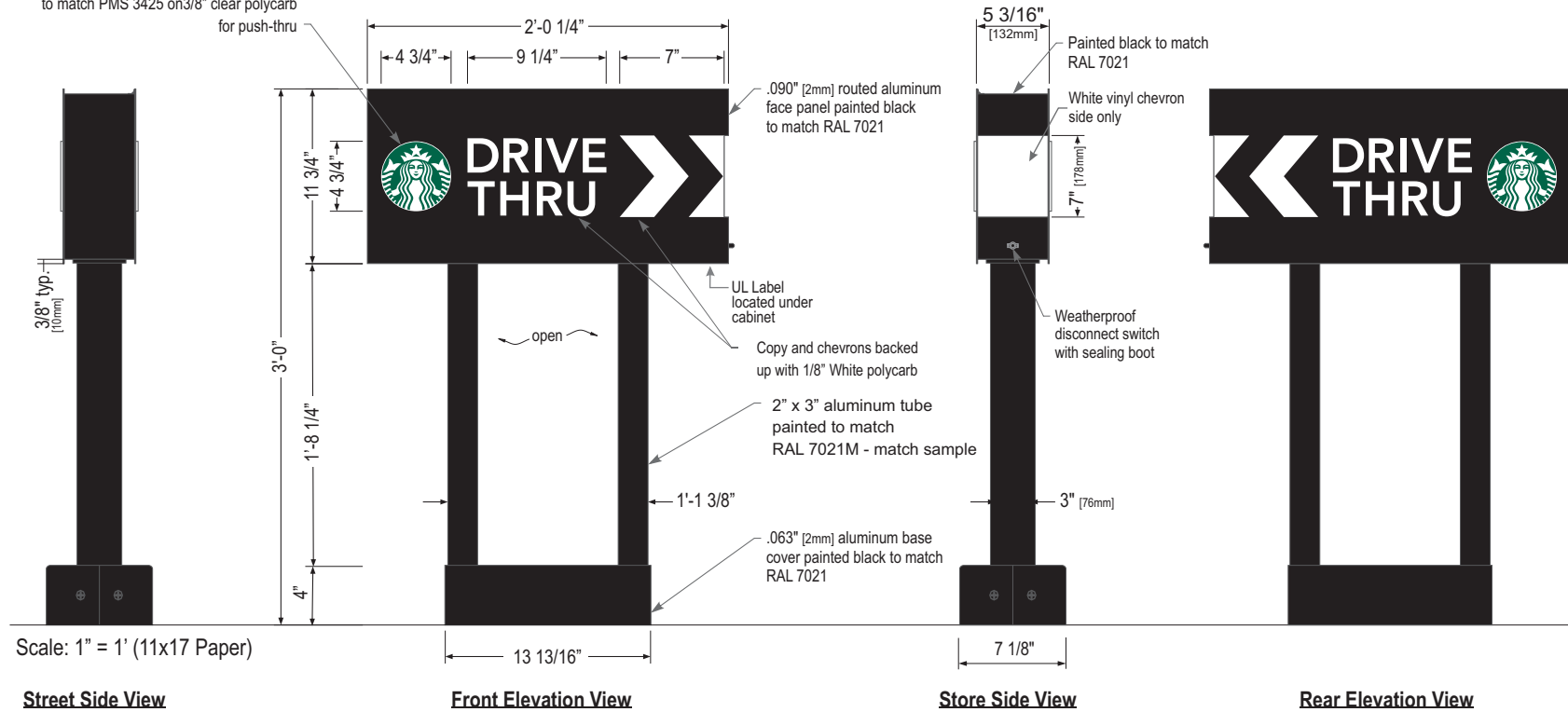

### Sign Specifications:

Fabricated .090" Aluminum cabinet painted black to match RAL 7021 with white end cap as shown. Directional copy and chevrons backed up with 1/8" white polycarbonate. Siren logo is 6" dia. , 3/8" clear polycarbonate routed push thru aluminum face. Logo decorated with 1st surface applied vinyl film to match PMS 3425. All polycarbonate face elements to be attached to interior face panels with welded studs. All interior portions of sign cabinet painted white. Graphic elements illuminated with Sloan Prism Enlighten LEDs. LEDs mounted on internal baffle with self contained LED power supply. All components accessible through face of cabinet.

### Support:

Support structure to be welded aluminum tube and plate construction painted black to match RAL 7021 Plate to be constructed to be retro-fittable to existing sign foundations. All foundations new and used to be analyzed for suitability and must meet all local city or state code regulations.



6" dia. halo lit logo has 3M 3630-76 Holly Green and 3630-20 White translucent vinyl film applied first surface to 3/8" Clear polycarbonate push thru with 3M 3735-60 White diffuser applied to second surface.

**HILTONDISPLAYS**  
 125 HILLSIDE DRIVE • GREENVILLE SC 29607  
 P 800 353 9132 • F 864 242 2204  
 www.hiltondisplays.com

**QID 19-46185**

**JOB NAME**

Starbucks 59763

**LOCATION**

2778 NC-24  
 CAMERON, NC 28326

**CUSTOMER CONTACT**

**SALESMAN / PM**

Stasia Rohn

**DESIGNER**

Chad Wike

**DWG. DATE**

9-23-21

**REV. DATE / REVISION**

1-19-22 CW

3-18-22 CW

3-31-22 CW

**SCALE**

As Noted

**FILE**

2021/Starbucks/Locations/  
 Cameron NC/19-46185/  
 SB Cameron NC 19-46185 BB

**DESIGN SPECIFICATIONS ACCEPTED BY:**

EST:	CLIENT:
SLS/PM:	LANDLORD:

THE INTENT OF THIS DRAWING IS TO SHOW A CONCEPTUAL REPRESENTATION OF THE PROPOSED SIGNAGE. DUE TO VARIATIONS IN PRINTING DEVICES AND SUBSTRATES, THE FINISHED PRODUCT MAY DIFFER SLIGHTLY FROM DRAWING.

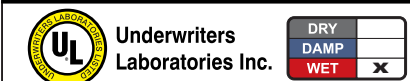

COLOR LEGEND		
	PMS/PAINT	VINYL
	PMS 3425 C	3M 3630-76
	RAL 7021M	3M 3630-22
	PMS WHITE	3M 3630-20/ 7725-10 TRANSLUCENT OPAQUE
	PMS 369 C	NA
	REFL. WHITE	3M 680-10

Size	Sq. Ft. <sup>1</sup>	Sq. Ft. <sup>2</sup>	Volts	Amps
36"	1.98	6.06	120	0.85

**36" ILLUMINATED DIRECTIONAL TY / EO**  
**SBC-AD3619-SL**

Qty. 1

F

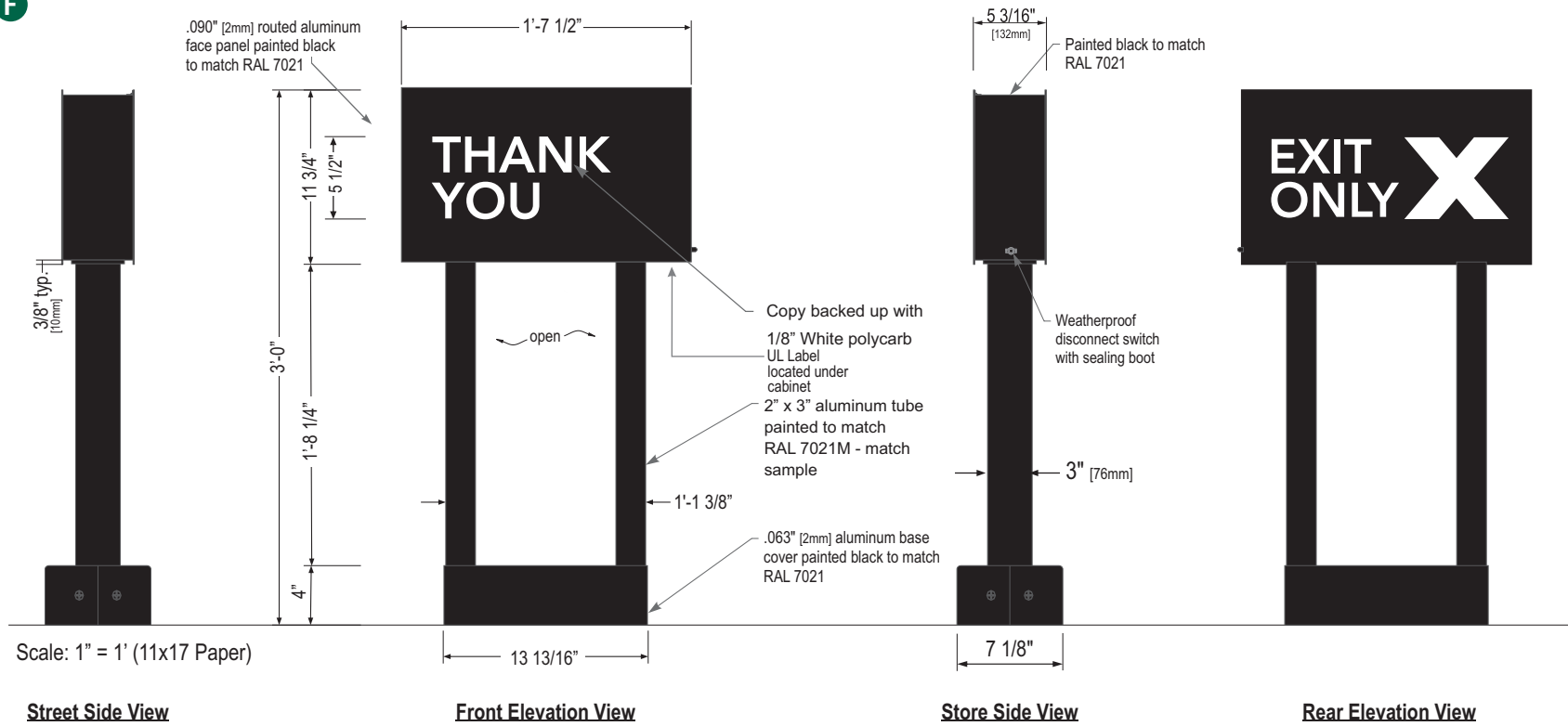

Scale: 1" = 1' (11x17 Paper)

Street Side View

Front Elevation View

Store Side View

Rear Elevation View

**Sign Specifications:**

Fabricated .090" Aluminum cabinet painted black to match RAL 7021 as shown. Directional copy and graphic backed up with 1/8" white polycarbonate. All polycarbonate face elements to be attached to interior face panels with welded studs. All interior portions of sign cabinet painted white. Graphic elements illuminated with Sloan Prism Enlighten LEDs. LEDs mounted on internal baffle with self contained LED power supply. All components accessible through face of cabinet.

**Support:**

Support structure to be welded aluminum tube and plate construction painted black to match RAL 7021 Plate to be constructed to be retro-fittable to existing sign foundations. All foundations new and used to be analyzed for suitability and must meet all local city or state code regulations.

**HILTONDISPLAYS**  
 125 HILLSIDE DRIVE • GREENVILLE SC 29607  
 P 800 353 9132 • F 864 242 2204  
 www.hiltondisplays.com

**QID 19-46185**

**JOB NAME**

Starbucks 59763

**LOCATION**

2778 NC-24  
 CAMERON, NC 28326

**CUSTOMER CONTACT**

**SALESMAN / PM**

Stasia Rohn

**DESIGNER**

Chad Wike

**DWG. DATE**

9-23-21

**REV. DATE / REVISION**

1-19-22 CW  
 3-18-22 CW  
 3-31-22 CW

**SCALE**

As Noted

**FILE**

2021/Starbucks/Locations/  
 Cameron NC/19-46185/  
 SB Cameron NC 19-46185 BB

**DESIGN SPECIFICATIONS ACCEPTED BY:**

EST:	CLIENT:
SLS/PM:	LANDLORD:

THE INTENT OF THIS DRAWING IS TO SHOW A CONCEPTUAL REPRESENTATION OF THE PROPOSED SIGNAGE. DUE TO VARIATIONS IN PRINTING DEVICES AND SUBSTRATES, THE FINISHED PRODUCT MAY DIFFER SLIGHTLY FROM DRAWING.

COLOR LEGEND		
	PMS/PAINT	VINYL
	PMS 3425 C	3M 3630-76
	RAL 7021M	3M 3630-22
	PMS WHITE	3M 3630-20/ 7725-10 TRANSLUCENT OPAQUE
	PMS 369 C	NA
	REFL. WHITE	3M 680-10

Size	Sq. Ft. <sup>1</sup>	Sq. Ft. <sup>2</sup>	Volts	Amps
36"	1.59	4.88	120	0.85

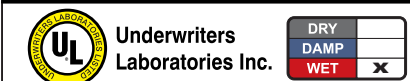

**ILLUMINATED BLADE MOP SIGN**

**SBC-MOPU-21163-IL-H-2**

Qty. 1

G

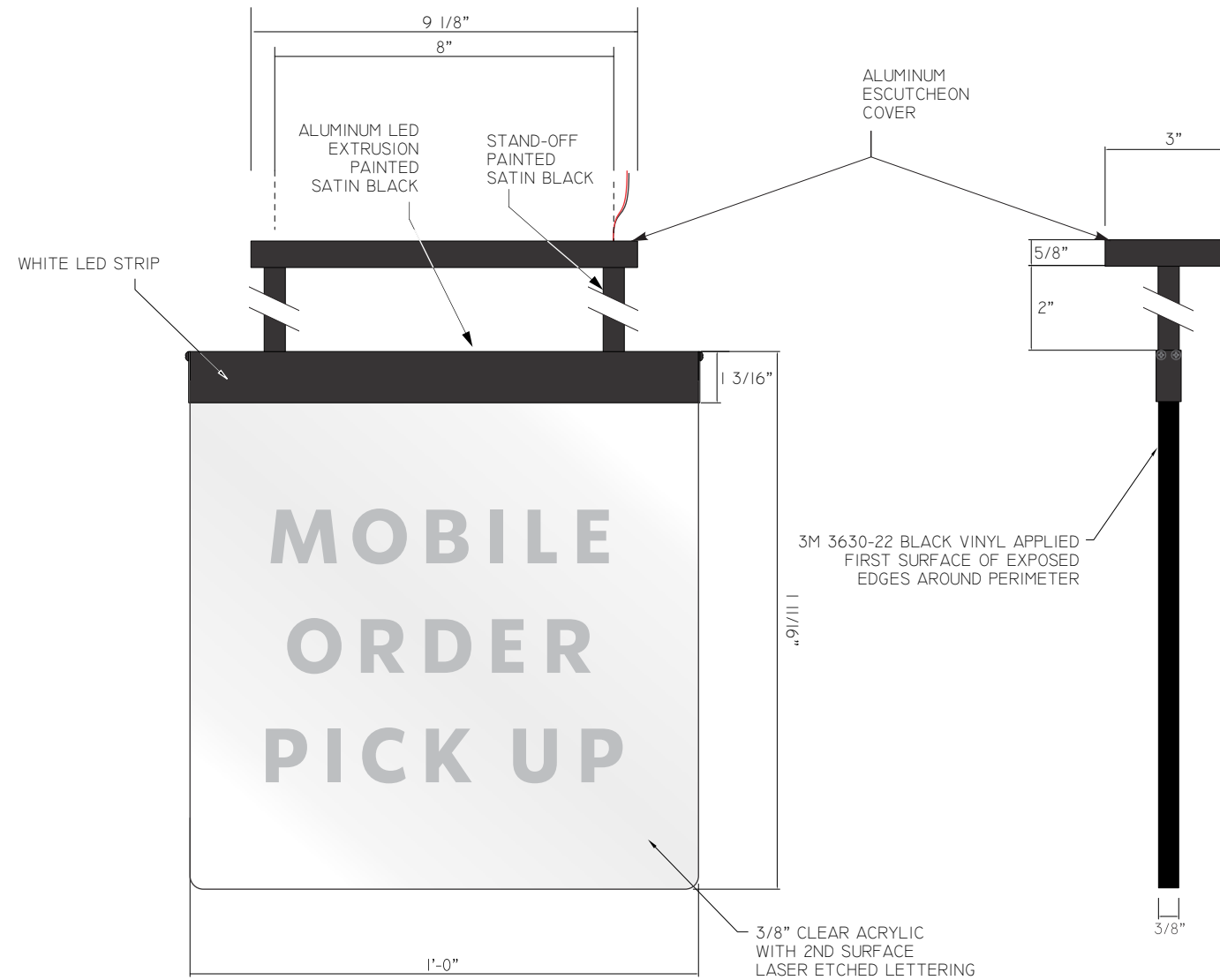

**FRONT VIEW**

**SIDE VIEW**

Scale: 3" = 1' (11x17 paper)



**REAR VIEW**

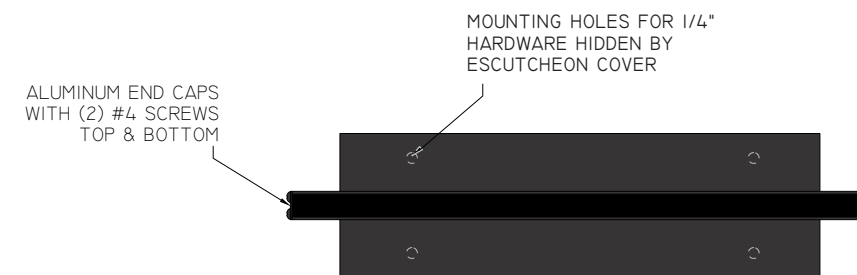

**BOTTOM VIEW**

**HILTONDISPLAYS**  
 125 HILLSIDE DRIVE • GREENVILLE SC 29607  
 P 800 353 9132 • F 864 242 2204  
 www.hiltondisplays.com

**QID 19-46185**

**JOB NAME**

Starbucks 59763

**LOCATION**

2778 NC-24  
CAMERON, NC 28326

**CUSTOMER CONTACT**

**SALESMAN / PM**

Stasia Rohn

**DESIGNER**

Chad Wike

**DWG. DATE**

9-23-21

**REV. DATE / REVISION**

1-19-22 CW

3-18-22 CW

3-31-22 CW

**SCALE**

As Noted

**FILE**

2021/Starbucks/Locations/  
Cameron NC/19-46185/  
SB Cameron NC 19-46185 BB

**DESIGN SPECIFICATIONS ACCEPTED BY:**

EST:	CLIENT:
SLS/PM:	LANDLORD:

THE INTENT OF THIS DRAWING IS TO SHOW A CONCEPTUAL REPRESENTATION OF THE PROPOSED SIGNAGE. DUE TO VARIATIONS IN PRINTING DEVICES AND SUBSTRATES, THE FINISHED PRODUCT MAY DIFFER SLIGHTLY FROM DRAWING.



# 4' ADJUSTABLE MOUNTING KIT

SBC-MOPU-EXT-KIT-4

Qty. 1

G

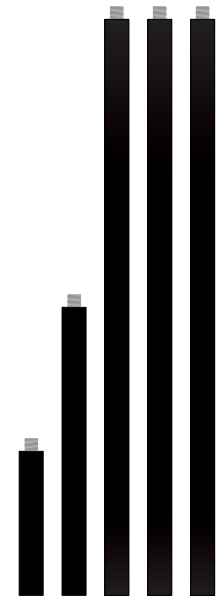
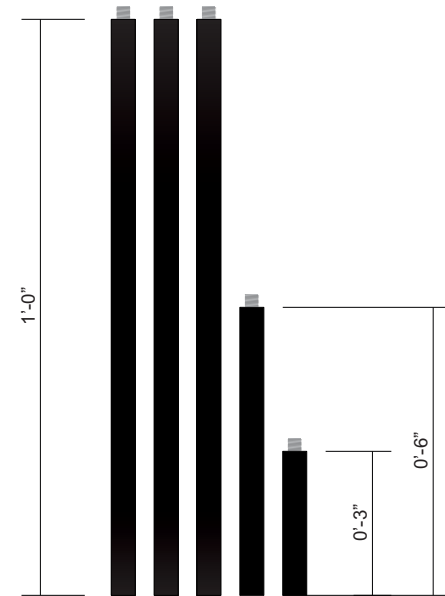

Scale: 3" = 1' (11x17 paper)

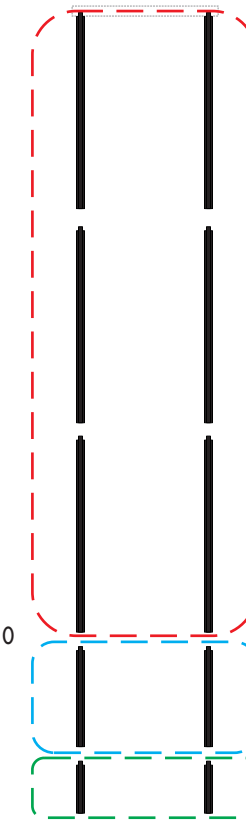

1" THREADED NIPPLE(S): QTY. 10

2" THREADED PIPE: QTY. 2  
\*PART OF STD. SIGN & SUPPORTS

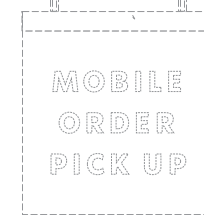

Scale: 1" = 1' (11x17 paper)

## STANDARD SIGN & SUPPORTS

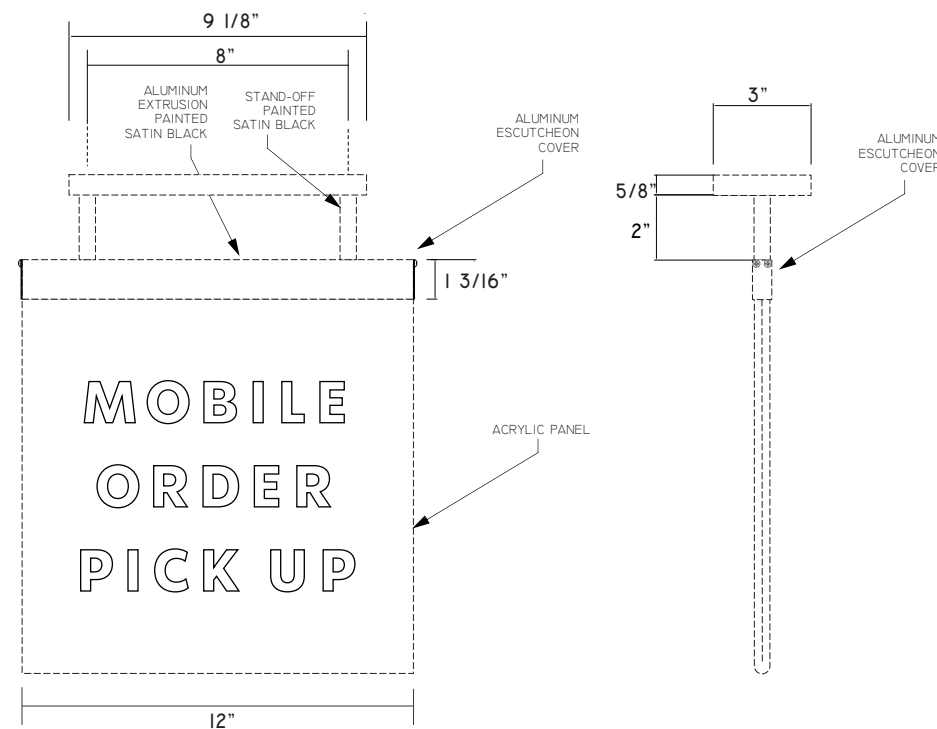

**HILTONDISPLAYS**  
125 HILLSIDE DRIVE • GREENVILLE SC 29607  
P 800 353 9132 • F 864 242 2204  
www.hiltondisplays.com

**QID 19-46185**

**JOB NAME**

Starbucks 59763

**LOCATION**

2778 NC-24  
CAMERON, NC 28326

**CUSTOMER CONTACT**

**SALESMAN / PM**

Stasia Rohn

**DESIGNER**

Chad Wike

**DWG. DATE**

9-23-21

**REV. DATE / REVISION**

1-19-22 CW

3-18-22 CW

3-31-22 CW

**SCALE**

As Noted

**FILE**

2021/Starbucks/Locations/  
Cameron NC/19-46185/  
SB Cameron NC 19-46185 BB

**DESIGN SPECIFICATIONS ACCEPTED BY:**

EST:	CLIENT:
SLS/PM:	LANDLORD:

THE INTENT OF THIS DRAWING IS TO SHOW A CONCEPTUAL REPRESENTATION OF THE PROPOSED SIGNAGE. DUE TO VARIATIONS IN PRINTING DEVICES AND SUBSTRATES, THE FINISHED PRODUCT MAY DIFFER SLIGHTLY FROM DRAWING.



**18" x 12" PARKING SIGN**

**SBC-PK-1812-UC-54-BP**

Qty. 2



**1** Front View  
SCALE: 3" = 1'-0"

**SPECIFICATIONS**

- A. .090" ALUMINUM PARKING SIGN TO BE PAINTED PMS 560c
- B. FACE TO HAVE APPLIED DIGITALLY PRINTED VINYL GRAPHICS ON WHITE REFLECTIVE VINYL w/5/16" WHITE REFLECTIVE BORDER.
- C. SIGN PANEL TO BE FASTENED TO U-CHANNEL POST W/ 5/16"x2" BOLTS (QTY. 2)
- D. SIGN POST TO BE U-CHANNEL (6' TALL, 2 1/4" WIDE)
- E. MOUNTED WITH PLATE MOUNTING BRACKET

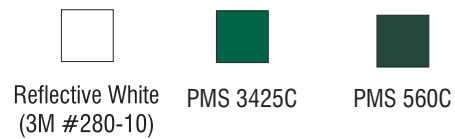

**2** Typical Elevation  
SCALE: 1" = 1'-0"

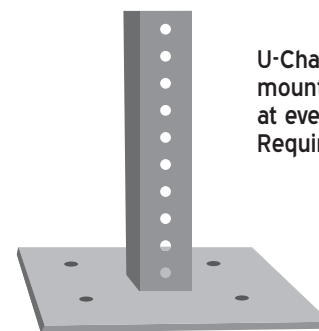
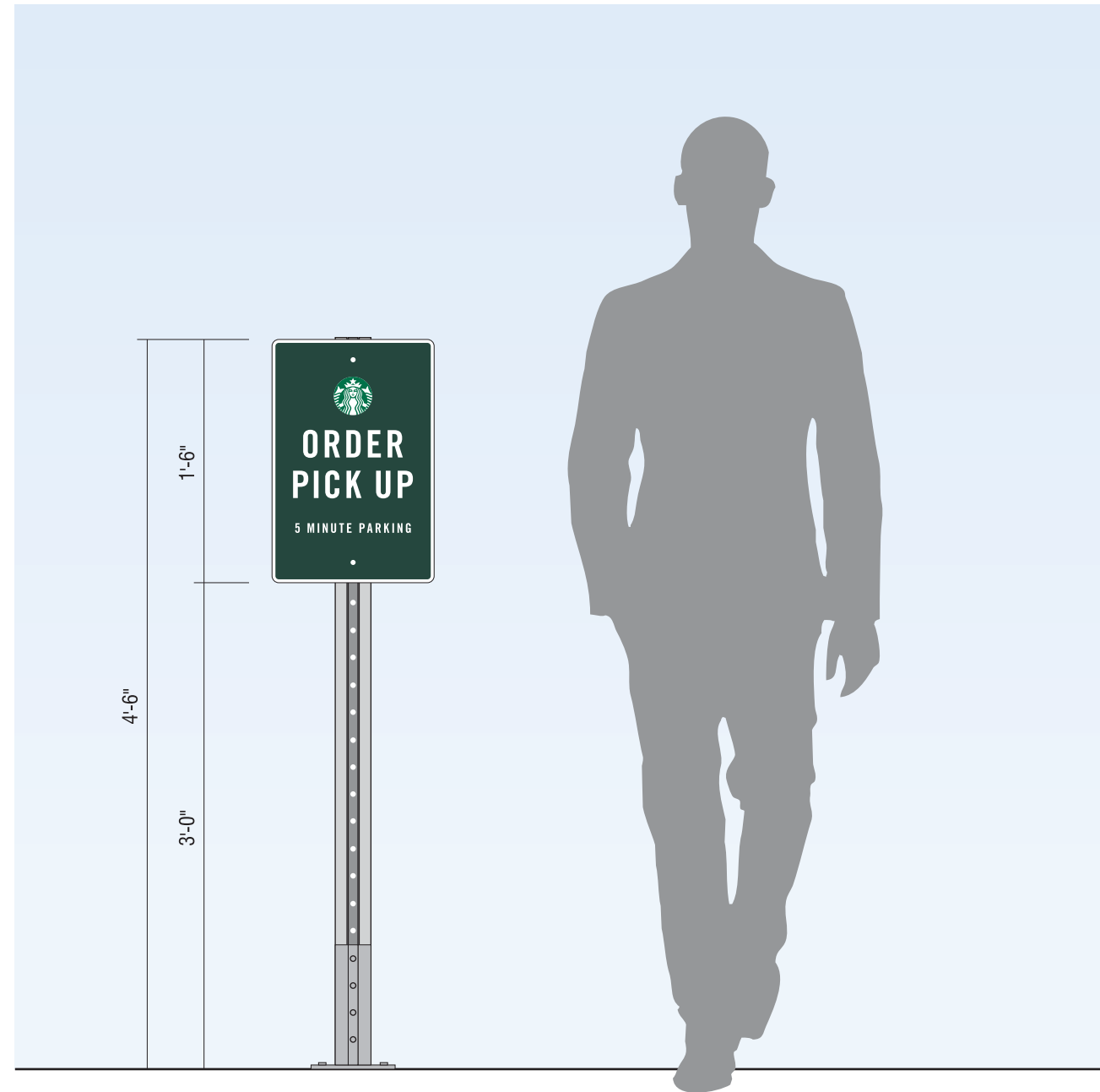

U-Channel Post Surface Mount Base w/ 10" Square (1/4" plate) and four 1/2" mounting holes welded to 10" tall 2lb/ft U-Channel Post Stub w/ 7/16" holes at every 1". Used to permanently and securely install U-Channel Post to concrete. Requires four concrete anchor bolts.

**HILTONDISPLAYS**  
125 HILLSIDE DRIVE • GREENVILLE SC 29607  
P 800 353 9132 • F 864 242 2204  
www.hiltondisplays.com

**QID 19-46185**

**JOB NAME**

Starbucks 59763

**LOCATION**

2778 NC-24  
CAMERON, NC 28326

**CUSTOMER CONTACT**

**SALESMAN / PM**

Stasia Rohn

**DESIGNER**

Chad Wike

**DWG. DATE**

9-23-21

**REV. DATE / REVISION**

1-19-22 CW

3-18-22 CW

3-31-22 CW

**SCALE**

As Noted

**FILE**

2021/Starbucks/Locations/  
Cameron NC/19-46185/  
SB Cameron NC 19-46185 BB

**DESIGN SPECIFICATIONS ACCEPTED BY:**

EST:	CLIENT:
SLS/PM:	LANDLORD:

THE INTENT OF THIS DRAWING IS TO SHOW A CONCEPTUAL REPRESENTATION OF THE PROPOSED SIGNAGE. DUE TO VARIATIONS IN PRINTING DEVICES AND SUBSTRATES, THE FINISHED PRODUCT MAY DIFFER SLIGHTLY FROM DRAWING.





# REVOLUTION CLEARANCE BAR

SBC-S22544-SHB-C-10

Qty. 1

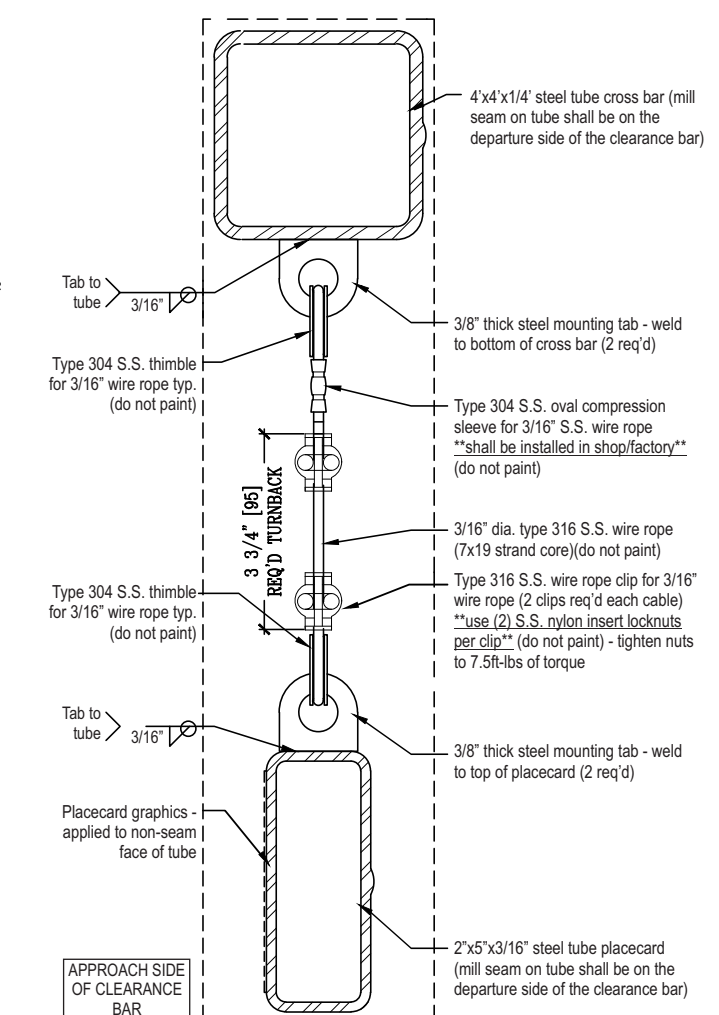
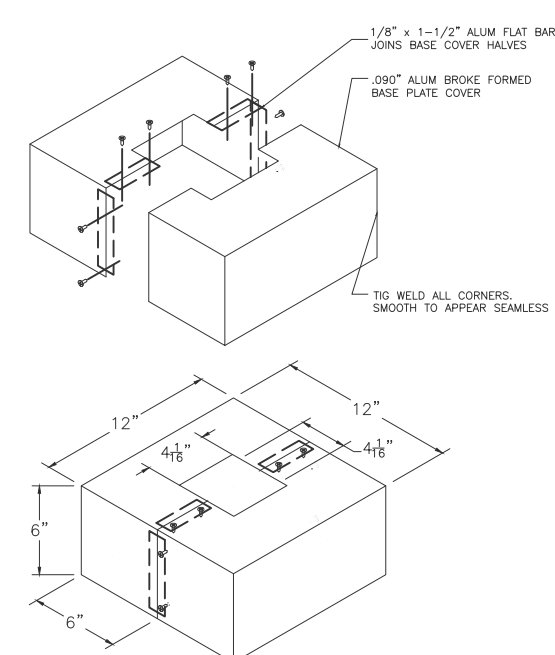
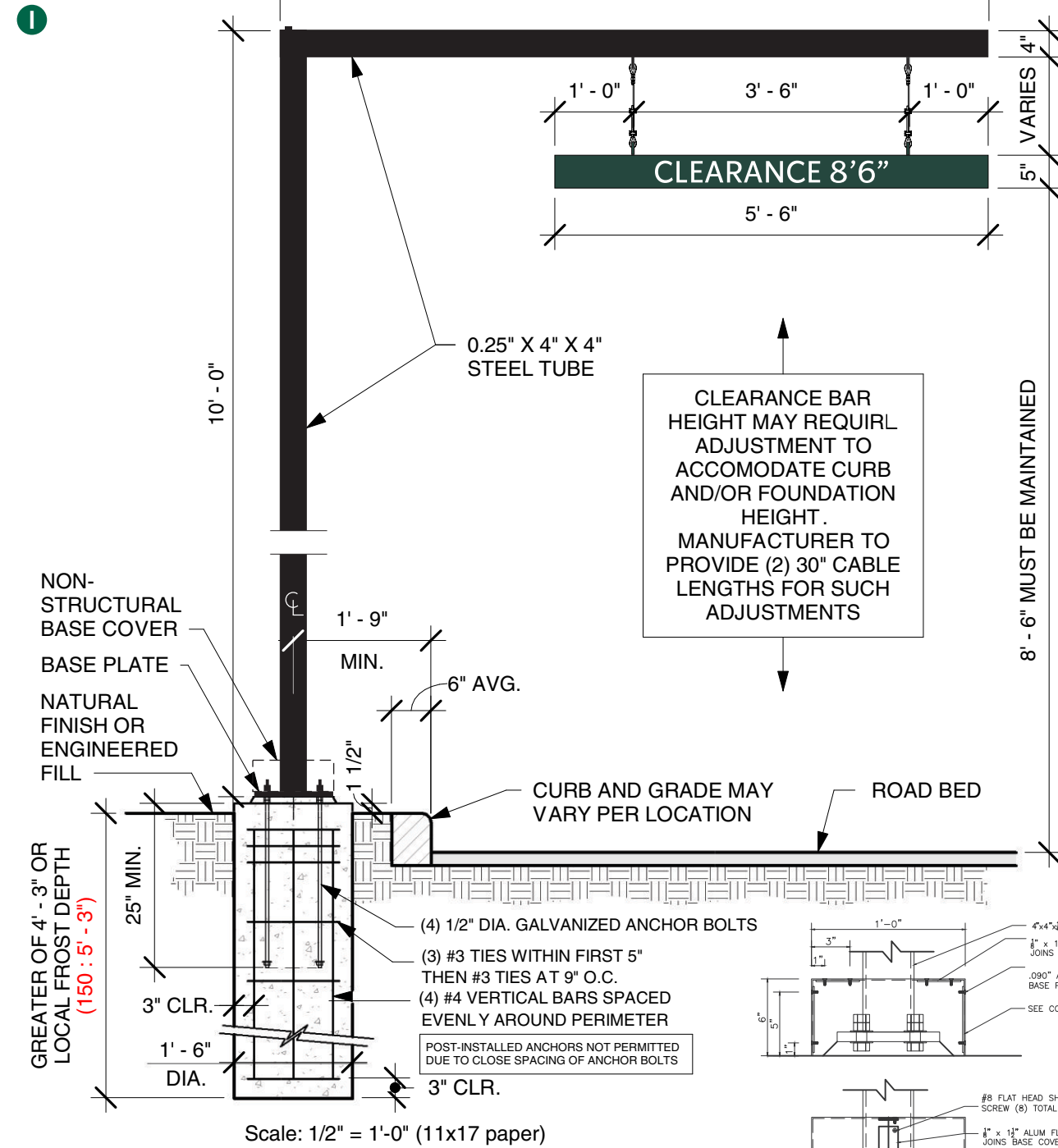

End Section View

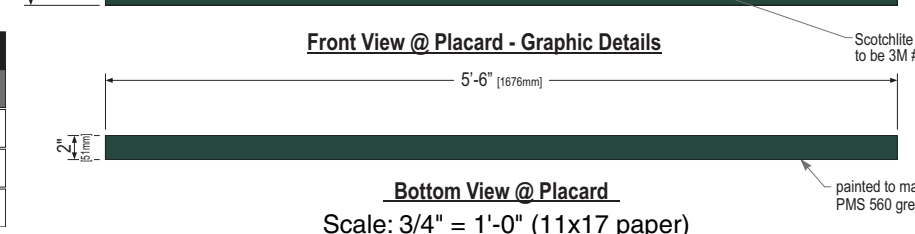
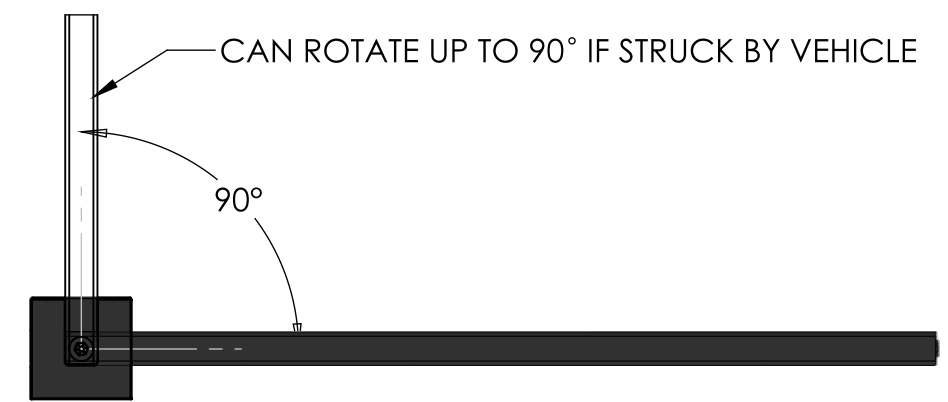

COLOR LEGEND		
PMS/PAINT	VINYL	
PMS 560 C	NA	
PSB 6865/ SATIN BLACK	3M 3630-22	
REFL. WHITE	3M 680-10	

**HILTONDISPLAYS**  
 125 HILLSIDE DRIVE • GREENVILLE SC 29607  
 P 800 353 9132 • F 864 242 2204  
 www.hiltondisplays.com

**QID 19-46185**

**JOB NAME**

Starbucks 59763

**LOCATION**

2778 NC-24  
CAMERON, NC 28326

**CUSTOMER CONTACT**

SALESMAN / PM

Stasia Rohn

**DESIGNER**

Chad Wike

**DWG. DATE**

9-23-21

**REV. DATE / REVISION**

1-19-22 CW

3-18-22 CW

3-31-22 CW

**SCALE**

As Noted

**FILE**

2021/Starbucks/Locations/  
Cameron NC/19-46185/  
SB Cameron NC 19-46185 BB

**DESIGN SPECIFICATIONS ACCEPTED BY:**

EST: CLIENT:

SLS/PM: LANDLORD:

THE INTENT OF THIS DRAWING IS TO SHOW A CONCEPTUAL REPRESENTATION OF THE PROPOSED SIGNAGE. DUE TO VARIATIONS IN PRINTING DEVICES AND SUBSTRATES, THE FINISHED PRODUCT MAY DIFFER SLIGHTLY FROM DRAWING.

Underwriters Laboratories Inc.

**PRE-MENU BOARD - INSTALL ONLY**

SBC-#

Qty. 1



**FRONT ELEVATION**

**SIDE ELEVATION**

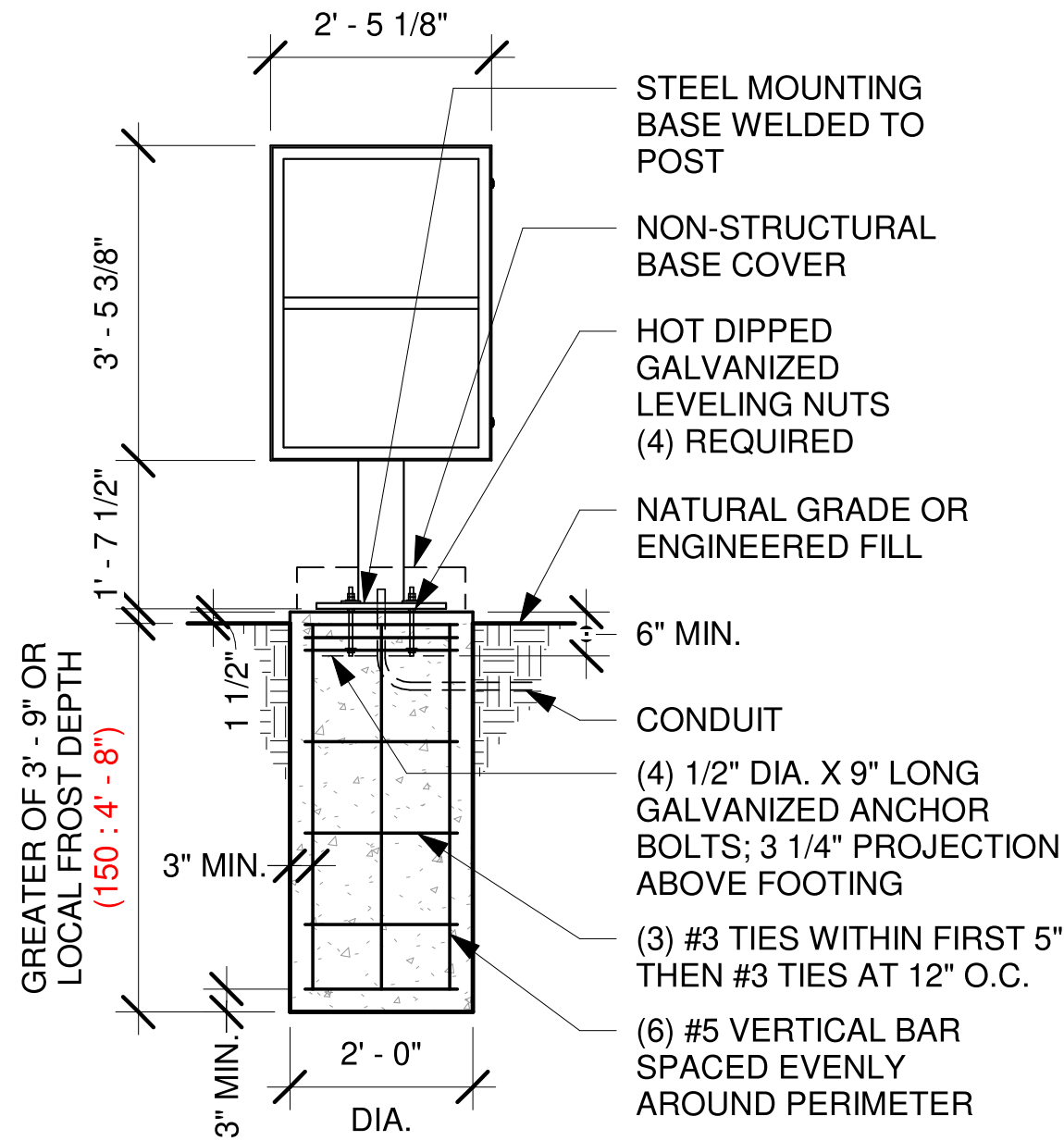

**HILTONDISPLAYS**  
 125 HILLSIDE DRIVE • GREENVILLE SC 29607  
 P 800 353 9132 • F 864 242 2204  
 www.hiltondisplays.com

**QID 19-46185**

**JOB NAME**

Starbucks 59763

**LOCATION**

2778 NC-24  
CAMERON, NC 28326

**CUSTOMER CONTACT**

**SALESMAN / PM**

Stasia Rohn

**DESIGNER**

Chad Wike

**DWG. DATE**

9-23-21

**REV. DATE / REVISION**

1-19-22 CW

3-18-22 CW

3-31-22 CW

**SCALE**

As Noted

**FILE**

2021/Starbucks/Locations/  
Cameron NC/19-46185/  
SB Cameron NC 19-46185 BB

**DESIGN SPECIFICATIONS ACCEPTED BY:**

EST: CLIENT:

SLS/PM: LANDLORD:

THE INTENT OF THIS DRAWING IS TO SHOW A CONCEPTUAL REPRESENTATION OF THE PROPOSED SIGNAGE. DUE TO VARIATIONS IN PRINTING DEVICES AND SUBSTRATES, THE FINISHED PRODUCT MAY DIFFER SLIGHTLY FROM DRAWING.

UL Underwriters Laboratories Inc. DRY DAMP WET

# CANOPY - INSTALL ONLY

SBC-#

Qty. 1

K

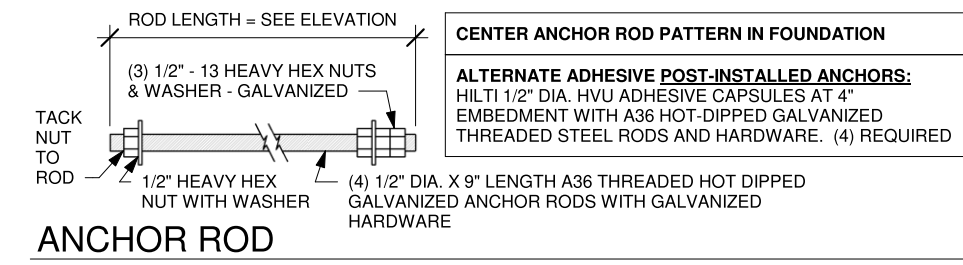
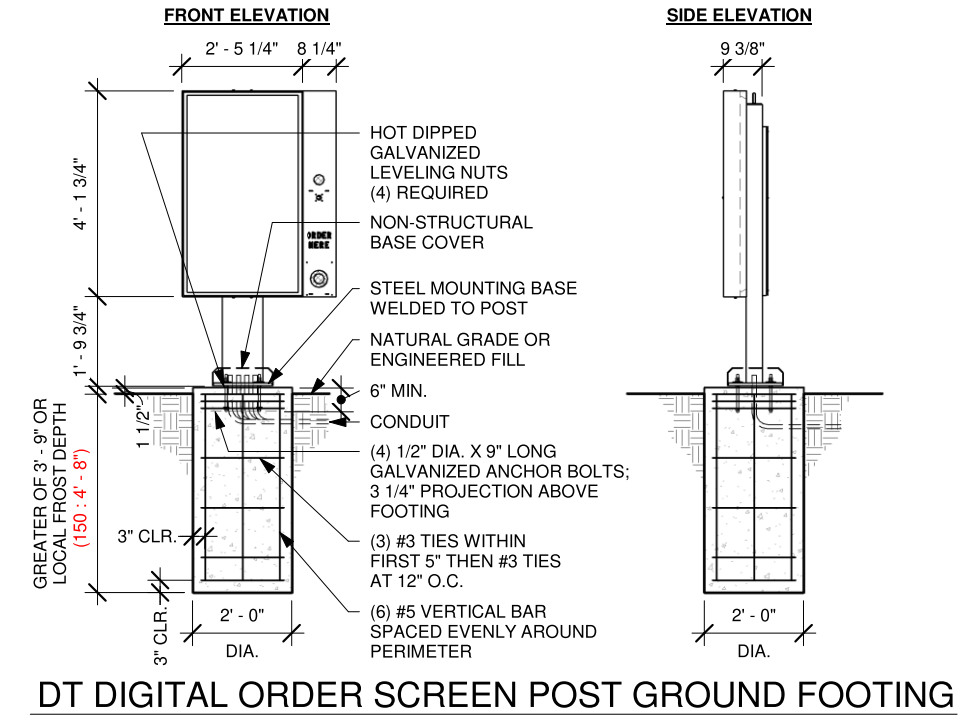
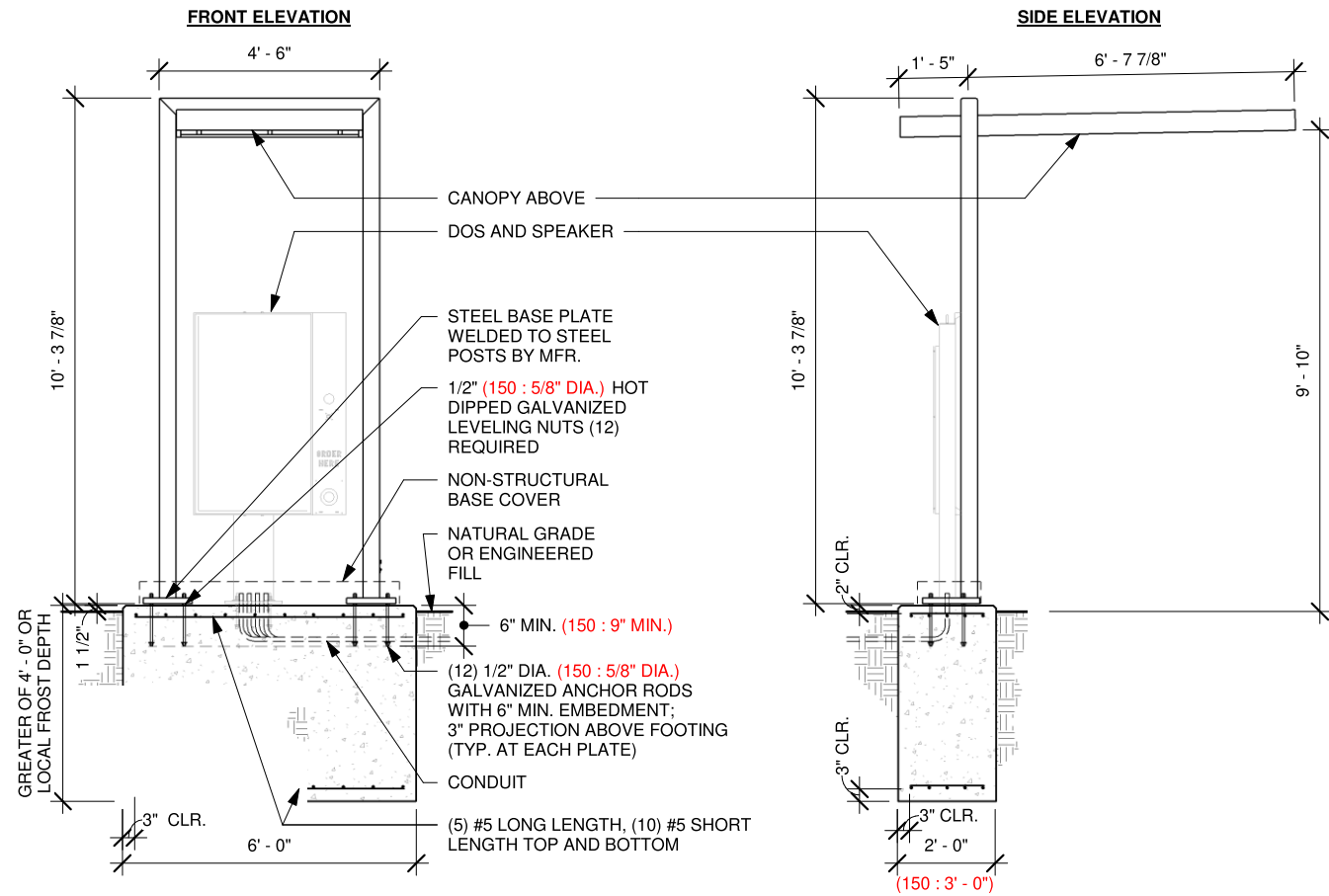

## ANCHOR ROD

DT DIGITAL ORDER SCREEN CANOPY GROUND FOOTING

DT DIGITAL ORDER SCREEN POST GROUND FOOTING



**HILTONDISPLAYS**  
 125 HILLSIDE DRIVE • GREENVILLE SC 29607  
 P 800 353 9132 • F 864 242 2204  
 www.hiltondisplays.com

**QID 19-46185**

**JOB NAME**

Starbucks 59763

**LOCATION**

2778 NC-24  
 CAMERON, NC 28326

**CUSTOMER CONTACT**

SALESMAN / PM

Stasia Rohn

**DESIGNER**

Chad Wike

**DWG. DATE**

9-23-21

**REV. DATE / REVISION**

1-19-22 CW

3-18-22 CW

3-31-22 CW

**SCALE**

As Noted

**FILE**

2021/Starbucks/Locations/  
 Cameron NC/19-46185/  
 SB Cameron NC 19-46185 BB

**DESIGN SPECIFICATIONS ACCEPTED BY:**

EST: CLIENT:

SLS/PM: LANDLORD:

THE INTENT OF THIS DRAWING IS TO SHOW A CONCEPTUAL REPRESENTATION OF THE PROPOSED SIGNAGE. DUE TO VARIATIONS IN PRINTING DEVICES AND SUBSTRATES, THE FINISHED PRODUCT MAY DIFFER SLIGHTLY FROM DRAWING.



**MENU BOARD - INSTALL ONLY**

SBC-#

Qty. 1



**HILTONDISPLAYS**  
 125 HILLSIDE DRIVE • GREENVILLE SC 29607  
 P 800 353 9132 • F 864 242 2204  
 www.hiltondisplays.com

**QID 19-46185**

**JOB NAME**

Starbucks 59763

**LOCATION**

2778 NC-24  
CAMERON, NC 28326

**CUSTOMER CONTACT**

**SALESMAN / PM**

Stasia Rohn

**DESIGNER**

Chad Wike

**DWG. DATE**

9-23-21

**REV. DATE / REVISION**

1-19-22 CW

3-18-22 CW

3-31-22 CW

**SCALE**

As Noted

**FILE**

2021/Starbucks/Locations/  
Cameron NC/19-46185/  
SB Cameron NC 19-46185 BB

**DESIGN SPECIFICATIONS ACCEPTED BY:**

EST: CLIENT:

SLS/PM: LANDLORD:

THE INTENT OF THIS DRAWING IS TO SHOW A CONCEPTUAL REPRESENTATION OF THE PROPOSED SIGNAGE. DUE TO VARIATIONS IN PRINTING DEVICES AND SUBSTRATES, THE FINISHED PRODUCT MAY DIFFER SLIGHTLY FROM DRAWING.

Underwriters Laboratories Inc. 

DRY	<input type="checkbox"/>
DAMP	<input type="checkbox"/>
WET	<input checked="" type="checkbox"/>

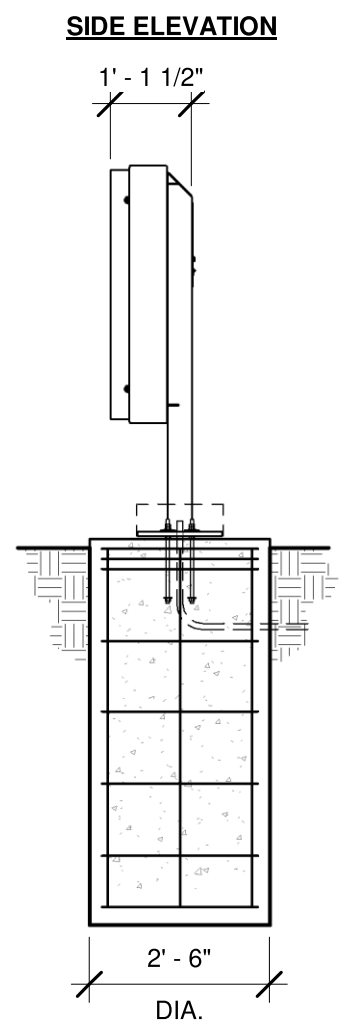
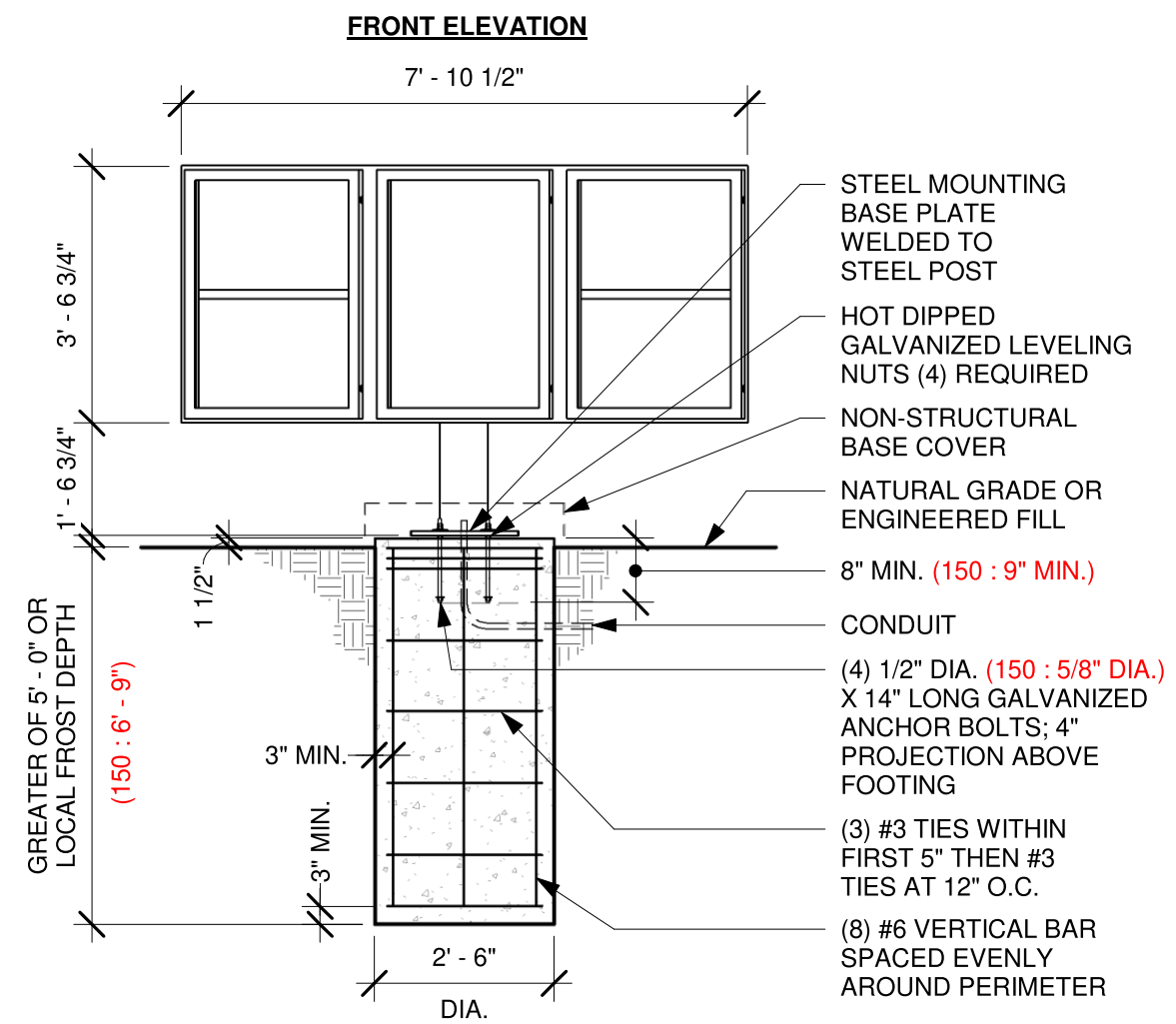

**DT 5-PANEL MENU BOARD GROUND FOOTING**

# 48" ILLUMINATED MONUMENT

Qty 1 SBC-PART#

M

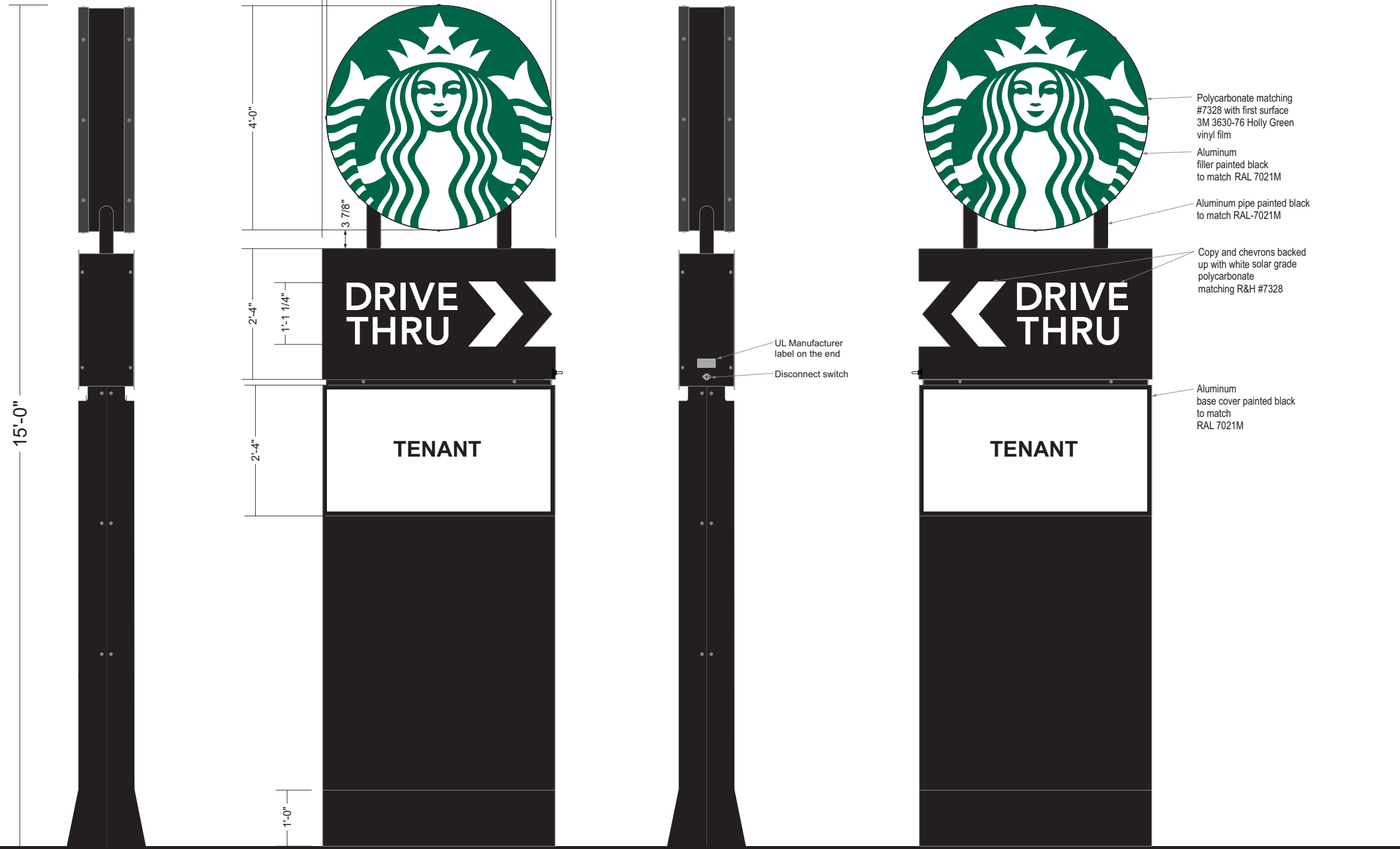

- Polycarbonate matching #7328 with first surface 3M 3630-76 Holly Green vinyl film
- Aluminum filler painted black to match RAL 7021M
- Aluminum pipe painted black to match RAL-7021M
- Copy and chevrons backed up with white solar grade polycarbonate matching R&H #7328
- Aluminum base cover painted black to match RAL 7021M

- UL Manufacturer label on the end
- Disconnect switch

### Street Side

Scale: 1/2" = 1' (11x17 paper)

### Side A

### Building Side

### Side B

### Sign Specifications:

#### Disk Cabinet:

- .063" aluminum filler painted black to match RAL 7021M.
- 1" black Jewelite.
- Areas using black paint to match RAL 7021M shall have a max 20% gloss level.
- 3/16" white solar grade polycarbonate matching R&H #7328 with first surface applied 3M 3630-76 Holly Green vinyl film.
- Interior aluminum surfaces of sign cabinet to be painted white with Lacryl Starbrite.
- All fasteners used in the assembly of internal components shall be coated to prevent corrosion.
- Graphic elements are internally illuminated using Sloan Prism Enlighten LED. All electrical components to be removable for service.

#### Drive Thru Cabinet:

- Fabricated .090" aluminum housing painted black to match RAL 7021M with 3M #180-10 white vinyl end cap as shown.
- Areas using black paint to match RAL 7021M shall have a max 20% gloss level.
- Directional copy backed up with .125" white solar grade polycarbonate matching R&H #7328 attached to aluminum face panel with welded studs.
- Interior aluminum surfaces of sign cabinet to be painted white with Lacryl Starbrite.
- Welded aluminum construction. All fasteners used in the assembly of internal components shall be coated to prevent corrosion.
- Graphic elements are internally illuminated using Sloan Prism Enlighten LED's to be mounted on an internal baffle with self-contained power supply. All electrical components to be removable for service.

#### Support:

- Supporting structure will be all welded aluminum tube, pipe, channel and plate construction painted black to match RAL 7021M
- .090" routed aluminum base cover with reveal painted black to match RAL 7021M.

Support structure and foundation type are subject to change upon review by licensed engineer if wind speeds based on geographic location of structure are greater than 115mph. Alternate wind speeds and soil conditions will result in alternate foundation type, structural tubing and/or pipe size used to support it.

COLOR LEGEND		
	PMS/PAINT	VINYL
	PMS 3425 C	3M 3630-76
	RAL 7021M	3M 3630-22
	PMS WHITE	3M 3630-20/ 7725-10 TRANSLUCENT OPAQUE
	PMS 369 C	NA
	REFL. WHITE	3M 680-10

## HILTONDISPLAYS

125 HILLSIDE DRIVE • GREENVILLE SC 29607  
P 800 353 9132 • F 864 242 2204  
www.hiltondisplays.com

**QID 19-46185**

### JOB NAME

Starbucks 59763

### LOCATION

2778 NC-24  
CAMERON, NC 28326

### CUSTOMER CONTACT

### SALESMAN / PM

Stasia Rohn

### DESIGNER

Chad Wike

### DWG. DATE

9-23-21

### REV. DATE / REVISION

1-19-22 CW

3-18-22 CW

3-31-22 CW

### SCALE

As Noted

### FILE

2021/Starbucks/Locations/  
Cameron NC/19-46185/  
SB Cameron NC 19-46185 BB

### DESIGN SPECIFICATIONS ACCEPTED BY:

EST:	CLIENT:
SLS/PM:	LANDLORD:

THE INTENT OF THIS DRAWING IS TO SHOW A CONCEPTUAL REPRESENTATION OF THE PROPOSED SIGNAGE. DUE TO VARIATIONS IN PRINTING DEVICES AND SUBSTRATES, THE FINISHED PRODUCT MAY DIFFER SLIGHTLY FROM DRAWING.



**PARKING SIGN**

SBC-PK-1812-UC-54-BP

Qty. 4

**N**



**1** Front View  
SCALE: 3" = 1'-0"

Reflective White  
(3M #280-10)

Black  
(3M # 3630-22)

**SPECIFICATIONS**

- A. .090" ALUMINUM PARKING SIGN TO BE PAINTED TO MATCH RAL 7021 BLACK
- B. FACE TO HAVE FIRST SURFACE 3M 280-10 REFLECTIVE WHITE VINYL GRAPHICS 3M 3630-76 GREEN
- C. SIGN PANEL TO BE FASTENED TO U-CHANNEL POST W/ 5/16"x2" BOLTS (QTY. 2)
- D. SIGN POST TO BE U-CHANNEL (6' TALL, 2 1/4" WIDE)
- E. MOUNTED WITH PLATE MOUNTING BRACKET

COLOR LEGEND		
	PMS/PAINT	VINYL
	PMS 3425 C	3M 3630-76
	RAL 7021M	3M 3630-22
	REFL. WHITE	3M 280-10



**2** Typical Elevation  
SCALE: 1" = 1'-0"

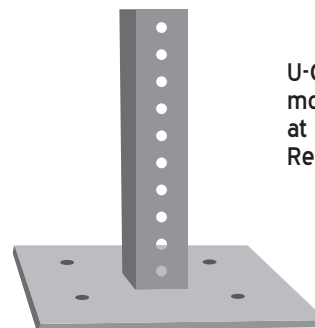

U-Channel Post Surface Mount Base w/ 10" Square (1/4" plate) and four 1/2" mounting holes welded to 10" tall 2lb/ft U-Channel Post Stub w/ 7/16" holes at every 1". Used to permanently and securely install U-Channel Post to concrete. Requires four concrete anchor bolts.

**HILTONDISPLAYS**

125 HILLSIDE DRIVE • GREENVILLE SC 29607  
P 800 353 9132 • F 864 242 2204  
www.hiltondisplays.com

**QID 19-46185**

**JOB NAME**

Starbucks 59763

**LOCATION**

2778 NC-24  
CAMERON, NC 28326

**CUSTOMER CONTACT**

**SALESMAN / PM**

Stasia Rohn

**DESIGNER**

Chad Wike

**DWG. DATE**

9-23-21

**REV. DATE / REVISION**

1-19-22 CW

3-18-22 CW

3-31-22 CW

**SCALE**

As Noted

**FILE**

2021/Starbucks/Locations/  
Cameron NC/19-46185/  
SB Cameron NC 19-46185 BB

**DESIGN SPECIFICATIONS ACCEPTED BY:**

EST:	CLIENT:
SLS/PM:	LANDLORD:

THE INTENT OF THIS DRAWING IS TO SHOW A CONCEPTUAL REPRESENTATION OF THE PROPOSED SIGNAGE. DUE TO VARIATIONS IN PRINTING DEVICES AND SUBSTRATES, THE FINISHED PRODUCT MAY DIFFER SLIGHTLY FROM DRAWING.

