

GENERAL CONSTRUCTION NOTES:

- ALL WORK SHALL CONFORM TO ALL CURRENT APPLICABLE FEDERAL, STATE, AND LOCAL CODES, INCLUDING ANSIEIA/TIA-222, AND COMPLY WITH ATC CONSTRUCTION SPECIFICATIONS.
- CONTRACTOR SHALL CONTACT LOCAL 811 FOR IDENTIFICATION OF UNDERGROUND UTILITIES PRIOR TO START OF CONSTRUCTION.
- CONTRACTOR SHALL BE RESPONSIBLE FOR COORDINATING ALL REQUIRED INSPECTIONS.
- ALL DIMENSIONS TO, OF, AND ON EXISTING BUILDINGS, DRAINAGE STRUCTURES, AND SITE IMPROVEMENTS SHALL BE VERIFIED IN FIELD BY CONTRACTOR WITH ALL DISCREPANCIES REPORTED TO THE ENGINEER.
- DO NOT CHANGE SIZE OR SPACING OF STRUCTURAL ELEMENTS.
- DETAILS SHOWN ARE TYPICAL; SIMILAR DETAILS APPLY TO SIMILAR CONDITIONS UNLESS OTHERWISE NOTED.
- THESE DRAWINGS DO NOT INCLUDE NECESSARY COMPONENTS FOR CONSTRUCTION SAFETY WHICH SHALL BE THE SOLE RESPONSIBILITY OF THE CONTRACTOR.
- CONTRACTOR SHALL BRACE STRUCTURES UNTIL ALL STRUCTURAL ELEMENTS NEEDED FOR STABILITY ARE INSTALLED. THESE ELEMENTS ARE AS FOLLOWS: LATERAL BRACING, ANCHOR BOLTS, ETC.
- CONTRACTOR SHALL DETERMINE EXACT LOCATION OF EXISTING UTILITIES, GROUNDS DRAINS, DRAIN PIPES, VENTS, ETC. BEFORE COMMENCING WORK.
- INCORRECTLY FABRICATED, DAMAGED, OR OTHERWISE MISFITTING OR NONCONFORMING MATERIALS OR CONDITIONS SHALL BE REPORTED TO THE ATC CM PRIOR TO REMEDIAL OR CORRECTIVE ACTION. ANY SUCH REMEDIAL ACTION SHALL REQUIRE WRITTEN APPROVAL BY THE ATC CM PRIOR TO PROCEEDING.
- EACH CONTRACTOR SHALL COOPERATE WITH THE ATC CM, AND COORDINATE HIS WORK WITH THE WORK OF OTHERS.
- CONTRACTOR SHALL REPAIR ANY DAMAGE CAUSED BY CONSTRUCTION OF THIS PROJECT TO MATCH EXISTING PRE-CONSTRUCTION CONDITIONS TO THE SATISFACTION OF THE ATC CONSTRUCTION MANAGER.
- ALL CABLE/CONDUIT ENTRY/EXIT PORTS SHALL BE WEATHERPROOFED DURING INSTALLATION USING A SILICONE SEALANT.
- WHERE EXISTING CONDITIONS DO NOT MATCH THOSE SHOWN IN THIS PLAN SET, CONTRACTOR SHALL NOTIFY THE ATC CONSTRUCTION MANAGER IMMEDIATELY.
- CONTRACTOR SHALL ENSURE ALL SUBCONTRACTORS ARE PROVIDED WITH A COMPLETE AND CURRENT SET OF DRAWINGS AND SPECIFICATIONS FOR THIS PROJECT.
- CONTRACTOR SHALL REMOVE ALL RUBBISH AND DEBRIS FROM THE SITE AT THE END OF EACH DAY.
- CONTRACTOR SHALL COORDINATE WORK SCHEDULE WITH LANDLORD AND TAKE PRECAUTIONS TO MINIMIZE IMPACT AND DISRUPTION OF OTHER OCCUPANTS OF THE FACILITY.
- CONTRACTOR SHALL FURNISH ATC WITH A PDF MARKED UP AS-BUILT SET OF DRAWINGS UPON COMPLETION OF WORK.
- PRIOR TO SUBMISSION OF BID, CONTRACTOR SHALL COORDINATE WITH ATC CM TO DETERMINE WHAT, IF ANY, ITEMS WILL BE PROVIDED. ALL ITEMS NOT PROVIDED SHALL BE PROVIDED AND INSTALLED BY THE CONTRACTOR. CONTRACTOR WILL INSTALL ALL ITEMS PROVIDED.
- PRIOR TO SUBMISSION OF BID, CONTRACTOR SHALL COORDINATE WITH ATC CONSTRUCTION MANAGER TO DETERMINE IF ANY PERMITS WILL BE OBTAINED BY ATC. ALL REQUIRED PERMITS NOT OBTAINED BY ATC MUST BE OBTAINED, AND PAID FOR, BY THE CONTRACTOR.
- CONTRACTOR SHALL INSTALL ALL SITE SIGNAGE IN ACCORDANCE WITH ATC SPECIFICATIONS AND REQUIREMENTS.
- CONTRACTOR SHALL SUBMIT ALL SHOP DRAWINGS TO ATC FOR REVIEW AND APPROVAL PRIOR TO FABRICATION.
- ALL EQUIPMENT SHALL BE INSTALLED ACCORDING TO MANUFACTURER'S SPECIFICATIONS AND LOCATED ACCORDING TO ATC SPECIFICATIONS, AND AS SHOWN IN THESE PLANS.
- THE CONTRACTOR SHALL SUPERVISE AND DIRECT THE PROJECT DESCRIBED HEREIN. THE CONTRACTOR SHALL BE SOLELY RESPONSIBLE FOR ALL THE CONSTRUCTION MEANS, METHODS, TECHNIQUES, SEQUENCES AND PROCEDURES AND FOR COORDINATING ALL PORTIONS OF THE WORK UNDER THE CONTRACT.
- CONTRACTOR SHALL NOTIFY ATC CM A MINIMUM OF 48 HOURS IN ADVANCE OF POURING CONCRETE OR BACKFILLING ANY UNDERGROUND UTILITIES, FOUNDATIONS OR SEALING ANY WALL, FLOOR OR ROOF PENETRATIONS FOR ENGINEERING REVIEW AND APPROVAL.
- CONTRACTOR SHALL BE RESPONSIBLE FOR SITE SAFETY INCLUDING COMPLIANCE WITH ALL APPLICABLE OSHA STANDARDS AND RECOMMENDATIONS AND SHALL PROVIDE ALL NECESSARY SAFETY DEVICES INCLUDING PPE AND PPM AND CONSTRUCTION DEVICES SUCH AS WELDING AND FIRE PREVENTION, TEMPORARY SHORING, SCAFFOLDING, TRENCH BOXES/SLOPING, BARRIERS, ETC.
- THE CONTRACTOR SHALL PROTECT AT HIS OWN EXPENSE, ALL EXISTING FACILITIES AND SUCH OF HIS NEW WORK LIABLE TO INJURY DURING THE CONSTRUCTION PERIOD. ANY DAMAGE CAUSED BY NEGLIGENCE ON THE PART OF THIS CONTRACTOR OR HIS REPRESENTATIVES, OR BY THE ELEMENTS DUE TO NEGLIGENCE ON THE PART OF THIS CONTRACTOR OR HIS

REPRESENTATIVES, EITHER TO THE EXISTING WORK, OR TO HIS WORK OR THE WORK OF ANY OTHER CONTRACTOR, SHALL BE REPAIRED AT HIS EXPENSE TO THE OWNER'S SATISFACTION.

- ALL WORK SHALL BE INSTALLED IN A FIRST CLASS, NEAT AND WORKMANLIKE MANNER BY MECHANICS SKILLED IN THE TRADE INVOLVED. THE QUALITY OF WORKMANSHIP SHALL BE SUBJECT TO THE APPROVAL OF THE ATC CM. ANY WORK FOUND BY THE ATC CM TO BE OF INFERIOR QUALITY AND/OR WORKMANSHIP SHALL BE REPLACED AND/OR REWORKED AT CONTRACTOR EXPENSE UNTIL APPROVAL IS OBTAINED.
- IN ORDER TO ESTABLISH STANDARDS OF QUALITY AND PERFORMANCE, ALL TYPES OF MATERIALS LISTED HEREINAFTER BY MANUFACTURER'S NAMES AND/OR MANUFACTURER'S CATALOG NUMBER SHALL BE PROVIDED BY THESE MANUFACTURERS AS SPECIFIED.

CONCRETE AND REINFORCING STEEL NOTES:

- DESIGN AND CONSTRUCTION OF ALL CONCRETE ELEMENTS SHALL CONFORM TO THE LATEST EDITIONS OF ALL APPLICABLE CODES INCLUDING: ACI 301 "SPECIFICATIONS FOR STRUCTURAL CONCRETE FOR BUILDINGS", ACI 117 "SPECIFICATIONS FOR TOLERANCES FOR CONCRETE CONSTRUCTION AND MATERIALS", AND ACI 318 "BUILDING CODE REQUIREMENTS FOR REINFORCED CONCRETE."
- MIX DESIGN SHALL BE APPROVED BY ATC CM PRIOR TO PLACING CONCRETE.
- CONCRETE SHALL BE NORMAL WEIGHT, 6 % AIR ENTRAINED (+/- 1.5%) WITH A SLUMP RANGE OF 3-5" AND HAVE A MINIMUM 28-DAY COMPRESSIVE STRENGTH OF 4000 PSI UNLESS OTHERWISE NOTED.
- THE FOLLOWING MATERIALS SHALL BE USED:
 - PORTLAND CEMENT: ASTM C150, TYPE 2
 - REINFORCEMENT: ASTM A185, PLAIN STEEL WELDED WIRE FABRIC
 - REINFORCEMENT BARS: ASTM A615, GRADE 60, DEFORMED
 - NORMAL WEIGHT AGGREGATE: ASTM C33
 - WATER: ASTM C 94/C 94M
 - ADMIXTURES:
 - WATER-REDUCING AGENT: ASTM C 494/C 494M, TYPE A
 - AIR-ENTERING AGENT: ASTM C 260/C 260M
 - SUPERPLASTICIZER: ASTM C494, TYPE F OR TYPE G
 - RETARDING: ASTM C 494/C 494M, TYPE B
- MINIMUM CONCRETE COVER FOR REINFORCING STEEL SHALL BE NO LESS THAN 3".
- A 3/4" CHAMFER SHALL BE PROVIDED AT ALL EXPOSED EDGES OF CONCRETE IN ACCORDANCE WITH ACI 301 SECTION 4.2.4, UNLESS NOTED OTHERWISE.
- INSTALLATION OF CONCRETE EXPANSION/WEDGE ANCHOR SHALL BE PER MANUFACTURER'S WRITTEN RECOMMENDED PROCEDURE. THE ANCHOR BOLT, DOWEL, OR ROD SHALL CONFORM TO MANUFACTURER'S RECOMMENDATION FOR EMBEDMENT DEPTH OR AS SHOWN ON THE DRAWINGS. NO REBAR SHALL BE CUT WITHOUT PRIOR ATC CM APPROVAL WHEN DRILLING HOLES IN CONCRETE.
- ADMIXTURES SHALL CONFORM TO THE APPROPRIATE ASTM STANDARD AS REFERENCED IN "METHOD 1" OF ACI 301.
- DO NOT WELD OR TACK WELD REINFORCING STEEL.
- ALL DOWELS, ANCHOR BOLTS, EMBEDDED STEEL, ELECTRICAL CONDUITS, PIPE SLEEVES, GROUNDS AND ALL OTHER EMBEDDED ITEMS AND FORMED DETAILS SHALL BE IN PLACE BEFORE START OF CONCRETE PLACEMENT.
- REINFORCEMENT SHALL BE COLD BENT WHENEVER BENDING IS REQUIRED.
- DO NOT PLACE CONCRETE IN WATER, ICE, OR ON FROZEN GROUND.
- DO NOT ALLOW REINFORCEMENT, CONCRETE OR SUBBASE TO FREEZE DURING CONCRETE CURING AND SETTING PERIOD, OR FOR A MINIMUM OF 3 DAYS AFTER PLACEMENT.
- FOR COLD-WEATHER(ACI 306) AND HOT-WEATHER(ACI 301M) CONCRETE PLACEMENT, CONFORM TO APPLICABLE ACI CODES AND RECOMMENDATIONS. IN EITHER CASE, MATERIALS CONTAINING CHLORIDE, CALCIUM, SALTS, ETC. SHALL NOT BE USED. PROTECT FRESH CONCRETE FROM WEATHER FOR 7 DAYS, MINIMUM.
- ALL CONCRETE SHALL HAVE A "SMOOTH FORM FINISH."
- UNLESS OTHERWISE NOTED:
 - A. ALL REINFORCING STEEL SHALL BE DEFORMED BARS CONFORMING TO ASTM A615/A 615M/A-996, GRADE 60.
 - B. WELDED WIRE FABRIC SHALL CONFORM TO ASTM A185.
- SPLICING OF REINFORCEMENT IS PERMITTED ONLY AT LOCATIONS SHOWN IN THE CONTRACT DRAWINGS OR AS ACCEPTED BY THE ENGINEER. UNLESS OTHERWISE SHOWN OR NOTED REINFORCING STEEL SHALL BE SPLICED TO DEVELOP ITS FULL TENSILE CAPACITY (CLASS A) IN ACCORDANCE WITH ACI 318.
- REINFORCING BAR DEVELOPMENT LENGTHS, AS COMPUTED IN ACCORDANCE WITH ACI 318, FORM THE BASIS FOR BAR EMBEDMENT LENGTHS AND BAR SPLICED LENGTHS SHOWN IN THE

DRAWINGS. APPLY APPROPRIATE MODIFICATION FACTORS FOR TOP STEEL, BAR SPACING, COVER AND THE LIKE.

- DETAILING OF REINFORCING STEEL SHALL CONFORM TO "ACI MANUAL OF STANDARD PRACTICE FOR DETAILING REINFORCED CONCRETE STRUCTURES" (ACI 315).
- ALL SLAB CONSTRUCTION SHALL BE CAST MONOLITHICALLY WITHOUT HORIZONTAL CONSTRUCTION JOINTS, UNLESS SHOWN IN THE CONTRACT DRAWINGS.
- LOCATION OF ALL CONSTRUCTION JOINTS ARE SUBJECT TO THE REQUIREMENTS OF THE CONTRACT DOCUMENTS, CONFORMANCE WITH ACI 318, AND ACCEPTANCE OF THE ENGINEER. DRAWINGS SHOWING LOCATION OF DETAILS OF THE PROPOSED CONSTRUCTION JOINTS SHALL BE SUBMITTED WITH REINFORCING STEEL PLACEMENT DRAWINGS.
- SPLICES OF WWF, AT ALL SPLICED EDGES, SHALL BE SUCH THAT THE OVERLAP MEASURED BETWEEN OUTERMOST CROSS WIRES OF EACH FABRIC SHEET IS NOT LESS THAN THE SPACING OF THE CROSS WIRE PLUS 2 INCHES, NOR LESS THAN 6".
- BAR SUPPORTS SHALL BE ALL-GALVINIZED METAL WITH PLASTIC TIPS.
- ALL REINFORCEMENT SHALL BE SECURELY TIED IN PLACE TO PREVENT DISPLACEMENT BY CONSTRUCTION TRAFFIC OR CONCRETE. TIE WIRE SHALL BE OF SUFFICIENT STRENGTH FOR INTENDED PURPOSE, BUT NOT LESS THAN NO. 18 GAUGE.
- SLAB ON GROUND:
 - A. COMPACT SUBGRADE AND ENSURE THERE IS PLACE 6" GRAVEL BENEATH SLAB.
 - B. PROVIDE VAPOR BARRIER BENEATH SLAB ON GROUND.

STRUCTURAL STEEL NOTES:

- STRUCTURAL STEEL SHALL CONFORM TO THE LATEST EDITION OF THE AISC "SPECIFICATION FOR THE DESIGN, FABRICATION AND ERECTION OF STRUCTURAL STEEL FOR BUILDINGS."
- STRUCTURAL STEEL ROLLED SHAPES, PLATES AND BARS SHALL CONFORM TO THE FOLLOWING ASTM DESIGNATIONS:
 - A. ASTM A-572, GRADE 50 - ALL W SHAPES, UNLESS NOTED OR A992 OTHERWISE
 - B. ASTM A-36 - ALL OTHER ROLLED SHAPES, PLATES AND BARS UNLESS NOTED OTHERWISE
 - C. ASTM A-500, GRADE B - HSS SECTION (SQUARE, RECTANGULAR, AND ROUND)
 - D. ASTM A-325, TYPE SC OR N - ALL BOLTS FOR CONNECTING STRUCTURAL MEMBERS
 - E. ASTM F-1554 07 - ALL ANCHOR BOLTS, UNLESS NOTED OTHERWISE
- ALL EXPOSED STRUCTURAL STEEL MEMBERS SHALL BE HOT-DIPPED GALVANIZED AFTER FABRICATION PER ASTM A123. EXPOSED STEEL HARDWARE AND ANCHOR BOLTS SHALL BE GALVANIZED PER ASTM A153 OR B695.
- ALL FIELD CUT SURFACES, FIELD DRILLED HOLES AND GROUND SURFACES WHERE EXISTING PAINT OR GALVANIZATION REMOVAL WAS REQUIRED SHALL BE REPAIRED WITH (2) BRUSHED COATS OF ZRC GALVILITE COLD GALVANIZING COMPOUND PER ASTM A780 AND MANUFACTURER'S RECOMMENDATIONS.
- DO NOT DRILL HOLES THROUGH STRUCTURAL STEEL MEMBERS EXCEPT AS SHOWN AND DETAILED ON STRUCTURAL DRAWINGS.
- CONNECTIONS:
 - A. ALL WELDING TO BE PERFORMED BY AWS CERTIFIED WELDERS AND CONDUCTED IN ACCORDANCE WITH THE LATEST EDITION OF THE AWS WELDING CODE D1.1.
 - B. ALL WELDS SHALL BE INSPECTED VISUALLY. 25% OF WELDS SHALL BE INSPECTED WITH DYE PENETRANT OR MAGNETIC PARTICLE TO MEET THE ACCEPTANCE CRITERIA OF AWS D1.1. REPAIR ALL WELDS AS NECESSARY.
 - C. INSPECTION SHALL BE PERFORMED BY AN AWS CERTIFIED WELD INSPECTOR.
 - D. IT IS THE CONTRACTORS RESPONSIBILITY TO PROVIDE BURNING/WELDING PERMITS AS REQUIRED BY LOCAL GOVERNING AUTHORITY AND IF REQUIRED SHALL HAVE FIRE DEPARTMENT DETAIL FOR ANY WELDING ACTIVITY.
 - E. ALL ELECTRODES TO BE LOW HYDROGEN, MATCHING FILLER METAL, PER AWS D1.1, UNLESS NOTED OTHERWISE.
 - F. MINIMUM WELD SIZE TO BE 0.1875 INCH FILLET WELDS, UNLESS NOTED OTHERWISE.
 - G. PRIOR TO FIELD WELDING GALVANIZING MATERIAL, CONTRACTOR SHALL GRIND OFF GALVANIZING 1/2" BEYOND ALL FIELD WELD SURFACES. AFTER WELD AND WELD INSPECTION IS COMPLETE, REPAIR ALL GROUND AND WELDED SURFACES WITH ZRC GALVILITE COLD GALVANIZING COMPOUND PER ASTM A780 AND MANUFACTURERS RECOMMENDATIONS.



AMERICAN TOWER®
A.T. ENGINEERING SERVICE, PLLC
 3500 REGENCY PARKWAY
 SUITE 100
 CARY, NC 27518
 PHONE: (919) 468-0112
 COA: P-1177

THESE DRAWINGS AND/OR THE ACCOMPANYING SPECIFICATION AS INSTRUMENTS OR SERVICE ARE THE EXCLUSIVE PROPERTY OF AMERICAN TOWER. THEIR USE AND PUBLICATION SHALL BE RESTRICTED TO THE ORIGINAL SITE FOR WHICH THEY ARE PREPARED. ANY USE OR DISCLOSURE OTHER THAN THAT WHICH RELATES TO AMERICAN TOWER OR THE SPECIFIED CARRIER IS STRICTLY PROHIBITED. TITLE TO THESE DOCUMENTS SHALL REMAIN THE PROPERTY OF AMERICAN TOWER WHETHER OR NOT THE PROJECT IS EXECUTED. NEITHER THE ARCHITECT NOR THE ENGINEER WILL BE PROVIDING ON-SITE CONSTRUCTION REVIEW OF THIS PROJECT. CONTRACTOR(S) MUST VERIFY ALL DIMENSIONS AND ADVISE AMERICAN TOWER OF ANY DISCREPANCIES. ANY PRIOR ISSUANCE OF THIS DRAWING IS SUPERSEDED BY THE LATEST VERSION ON FILE WITH AMERICAN TOWER.

REV.	DESCRIPTION	BY	DATE
0	FOR CONSTRUCTION	DB	09/09/20

ATC SITE NUMBER:

21275

ATC SITE NAME:

CALVARY CHURCH NC

SITE ADDRESS:

503 CALVARY CHURCH ROAD
 SANFORD, NC 27332

SEAL:



DRAWN BY:	DB
APPROVED BY:	MR
DATE DRAWN:	09/09/20
ATC JOB NO:	13320880_E2

GENERAL NOTES

SHEET NUMBER:
G-002

REVISION:
0

Copyright © 2020 ATC IP, LLC. All Rights Reserved.

SITE PLAN NOTES:

- THIS SITE PLAN REPRESENTS THE BEST PRESENT KNOWLEDGE AVAILABLE TO THE ENGINEER AT THE TIME OF THIS DESIGN. THE CONTRACTOR SHALL VISIT THE SITE PRIOR TO CONSTRUCTION AND VERIFY ALL EXISTING CONDITIONS RELATED TO THE SCOPE OF WORK FOR THIS PROJECT.
- ICE BRIDGE, CABLE LADDER, COAX PORT, AND COAX CABLE ARE SHOWN FOR REFERENCE ONLY. CONTRACTOR SHALL CONFIRM THE EXACT LOCATION OF ALL PROPOSED AND EXISTING EQUIPMENT AND STRUCTURES DEPICTED ON THIS PLAN. BEFORE UTILIZING EXISTING CABLE SUPPORTS, COAX PORTS, INSTALLING NEW PORTS OR ANY OTHER EQUIPMENT, CONTRACTOR SHALL VERIFY ALL ASPECTS OF THE COMPONENTS MEET THE ATC SPECIFICATIONS.
- IT IS THE RESPONSIBILITY OF THE CONTRACTOR TO COORDINATE WITH THE ATC CONSTRUCTION MANAGER AND LOCAL UTILITY COMPANY FOR THE INSTALLATION OF CONDUITS, CONDUCTORS, BREAKERS, DISCONNECTS, OR ANY OTHER EQUIPMENT REQUIRED FOR ELECTRICAL SERVICE. ALL ELECTRICAL WORK SHALL BE PERFORMED IN ACCORDANCE WITH LATEST EDITION OF THE STATE AND NATIONAL CODES, ORDINANCES AND REGULATIONS APPLICABLE TO THIS PROJECT.
- CONTRACTOR SHALL INSURE THAT ALL WORKING SPACE REQUIREMENTS ARE MET PER APPLICABLE CODES AND MANUFACTURER SPECIFICATIONS.
- ABOVE GROUND CONDUITS NEED TO BE SUPPORTED/FASTENED PER NEC 344, NEC 352, AND PER ATC CONSTRUCTION SPECIFICATIONS.
- THE FOLLOWING SIGNS SHALL BE INSTALLED AT TENANT SERVICE MAIN DISCONNECT PER NEC 702.7.
 - "CAUTION: TWO SOURCES OF SUPPLY STANDBY GENERATOR LOCATED OUTDOORS"
 - "WARNING: SHOCK HAZARD EXISTS IF GROUNDING ELECTRODE CONDUCTOR OR BONDING JUMPER CONNECTION IN THIS EQUIPMENT IS REMOVED WHILE ALTERNATE SOURCE IS ENERGIZED"

RODENT CONTROL AROUND GENERATOR ENVELOPE:

- SEAL ALL CONDUITS INCLUDING CONDUITS ENTERING GENERATOR EQUIPMENT, BOXES, ATTACHMENTS, ETC. WITH RODENT FOAM SEALANT.

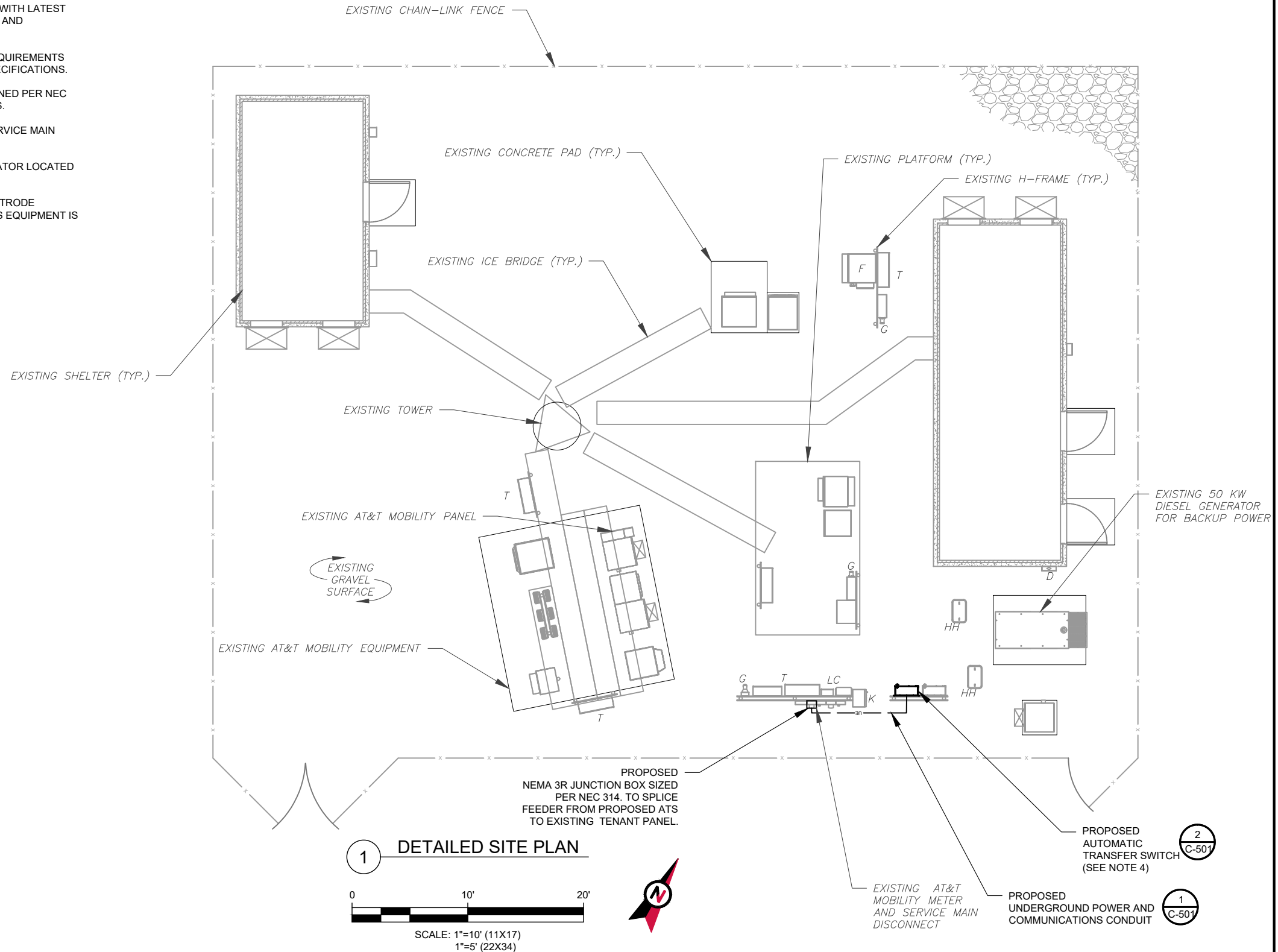

LEGEND	
⊗	GROUNDING TEST WELL
ATS	AUTOMATIC TRANSFER SWITCH
B	BOLLARD
CSC	CELL SITE CABINET
D	DISCONNECT
E	ELECTRICAL
F	FIBER
GEN	GENERATOR
G	GENERATOR RECEPTACAL
HH, V	HAND HOLE, VAULT
IB	ICE BRIDGE
K	KENTROX BOX
LC	LIGHTING CONTROL
M	METER
PB	PULL BOX
PP	POWER POLE
T	TELCO
TRN	TRANSFORMER
x	CHAINLINK FENCE

APPROXIMATE TRENCH DISTANCES	
8"	DISTANCE FROM ATS TO POWER SOURCE

AMERICAN TOWER®
A.T. ENGINEERING SERVICE, PLLC
 3500 REGENCY PARKWAY
 SUITE 100
 CARY, NC 27518
 PHONE: (919) 468-0112
 COA: P-1177

THESE DRAWINGS AND/OR THE ACCOMPANYING SPECIFICATION AS INSTRUMENTS OR SERVICE ARE THE EXCLUSIVE PROPERTY OF AMERICAN TOWER. THEIR USE AND PUBLICATION SHALL BE RESTRICTED TO THE ORIGINAL SITE FOR WHICH THEY ARE PREPARED. ANY USE OR DISCLOSURE OTHER THAN THAT WHICH RELATES TO AMERICAN TOWER OR THE SPECIFIED CARRIER IS STRICTLY PROHIBITED. TITLE TO THESE DOCUMENTS SHALL REMAIN THE PROPERTY OF AMERICAN TOWER WHETHER OR NOT THE PROJECT IS EXECUTED. NEITHER THE ARCHITECT NOR THE ENGINEER WILL BE PROVIDING ON-SITE CONSTRUCTION REVIEW OF THIS PROJECT. CONTRACTOR(S) MUST VERIFY ALL DIMENSIONS AND ADVISE AMERICAN TOWER OF ANY DISCREPANCIES. ANY PRIOR ISSUANCE OF THIS DRAWING IS SUPERSEDED BY THE LATEST VERSION ON FILE WITH AMERICAN TOWER.

REV.	DESCRIPTION	BY	DATE
0	FOR CONSTRUCTION	DB	09/09/20

ATC SITE NUMBER:
21275
 ATC SITE NAME:
CALVARY CHURCH NC
 SITE ADDRESS:
 503 CALVARY CHURCH ROAD
 SANFORD, NC 27332



DRAWN BY:	DB
APPROVED BY:	MR
DATE DRAWN:	09/09/20
ATC JOB NO:	13320880_E2

SITE PLAN	
SHEET NUMBER:	REVISION:
C-101	0

Copyright © 2020 ATC IP LLC. All Rights Reserved.

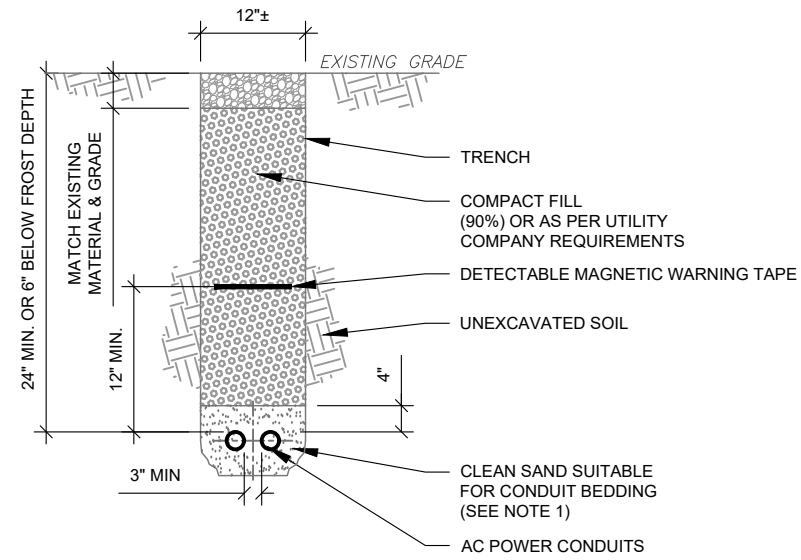

TRENCH NOTES:

1. IF FREE OF ORGANIC OR OTHER DELETERIOUS MATERIAL, EXCAVATED MATERIAL MAY BE USED FOR BACKFILL. IF NOT, PROVIDE CLEAN, COMPACTIBLE MATERIAL.
2. COMPACT IN 8" LIFTS USING A MECHANICAL PLATE TAMPER, MIN 3 PASSES. REMOVE ANY LARGE ROCKS PRIOR TO BACKFILLING. CONTRACTOR TO VERIFY LOCATION OF EXISTING U/G UTILITIES PRIOR TO DIGGING. SEE ATC CONSTRUCTION SPECIFICATION 312000 SECTION 3.15.
3. IF CURRENT AS-BUILT DRAWINGS ARE NOT AVAILABLE CONTRACTOR SHALL HAND DIG U/G TRENCHING.
4. CONFIRM SPACING AND DEPTH WITH NEC OR LOCAL CODE REQUIREMENTS

1 AC POWER CONDUIT TRENCH

SCALE: N.T.S.

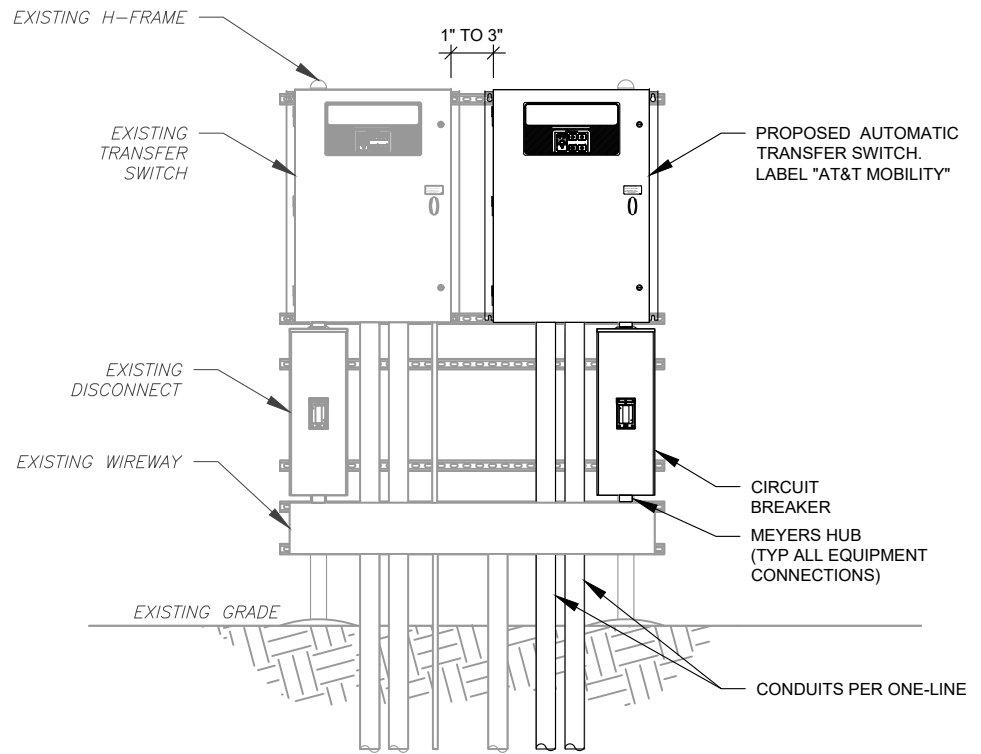

H-FRAME NOTES:

1. IF IT IS NECESSARY TO EXTEND THE H-FRAME, AN ADDITIONAL POST SHALL BE REQUIRED.
2. PROPOSED UNISTRUTS TO BE FIELD CUT AND SHALL NOT EXTEND MORE THAN 6 INCHES BEYOND THE LAST POST.
3. SPRAY ENDS OF UNISTRUT WITH COLD GALVANIZING SPRAY PAINT, ALLOW TO DRY, THEN COVER WITH RUBBER PROTECTIVE CAPS FOR SAFETY.
4. UNISTRUT TO BE CUT FLUSH WITH NO SHARP OR JAGGED EDGES.
5. ALL PROPOSED HARDWARE TO BE MOUNTED AND GROUNDED PER MANUFACTURERS SPECS
6. ALL ITEMS ARE PROPOSED UNLESS OTHERWISE NOTED.
7. LAYOUT H-FRAME & PROPOSED EQUIPMENT EXACTLY AS SHOWN TO ALLOW FOR FUTURE EQUIPMENT. ANY DEVIATIONS MUST BE APPROVED BY ATC CM, IN WRITING, NO EXCEPTIONS.
8. FOOTINGS SHALL BE ONE OF THE FOLLOWING: USS POLECRETE STABILIZER SYSTEM, PRECAST CONCRETE (WHERE ALLOWED BY JURISDICTION) OR CAST IN PLACE. FOR PRECAST FOOTINGS, CONTRACTORS SHALL THOROUGHLY COMPACT THE PERIMETER (2' MIN) OF FOOTING WITH MECHANICAL PLATE TAMPER.

2 H-FRAME

SCALE: N.T.S.



3 EXISTING H-FRAME

AMERICAN TOWER®
A.T. ENGINEERING SERVICE, PLLC
 3500 REGENCY PARKWAY
 SUITE 100
 CARY, NC 27518
 PHONE: (919) 468-0112
 COA: P-1177

THESE DRAWINGS AND/OR THE ACCOMPANYING SPECIFICATION AS INSTRUMENTS OR SERVICE ARE THE EXCLUSIVE PROPERTY OF AMERICAN TOWER. THEIR USE AND PUBLICATION SHALL BE RESTRICTED TO THE ORIGINAL SITE FOR WHICH THEY ARE PREPARED. ANY USE OR DISCLOSURE OTHER THAN THAT WHICH RELATES TO AMERICAN TOWER OR THE SPECIFIED CARRIER IS STRICTLY PROHIBITED. TITLE TO THESE DOCUMENTS SHALL REMAIN THE PROPERTY OF AMERICAN TOWER WHETHER OR NOT THE PROJECT IS EXECUTED. NEITHER THE ARCHITECT NOR THE ENGINEER WILL BE PROVIDING ON-SITE CONSTRUCTION REVIEW OF THIS PROJECT. CONTRACTOR(S) MUST VERIFY ALL DIMENSIONS AND ADVISE AMERICAN TOWER OF ANY DISCREPANCIES. ANY PRIOR ISSUANCE OF THIS DRAWING IS SUPERSEDED BY THE LATEST VERSION ON FILE WITH AMERICAN TOWER.

REV.	DESCRIPTION	BY	DATE
0	FOR CONSTRUCTION	DB	09/09/20

ATC SITE NUMBER:
21275
 ATC SITE NAME:
CALVARY CHURCH NC
 SITE ADDRESS:
 503 CALVARY CHURCH ROAD
 SANFORD, NC 27332

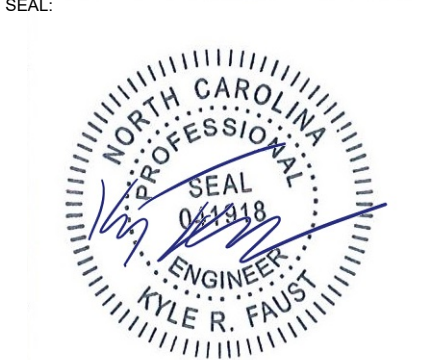

DRAWN BY:	DB
APPROVED BY:	MR
DATE DRAWN:	09/09/20
ATC JOB NO:	13320880_E2

TRENCHING AND H-FRAME DETAILS

SHEET NUMBER:	REVISION:
C-501	0

Copyright © 2020 ATC IP, LLC. All Rights Reserved.



AMERICAN TOWER®
A.T. ENGINEERING SERVICE, PLLC
 3500 REGENCY PARKWAY
 SUITE 100
 CARY, NC 27518
 PHONE: (919) 468-0112
 COA: P-1177

THESE DRAWINGS AND/OR THE ACCOMPANYING SPECIFICATION AS INSTRUMENTS OR SERVICE ARE THE EXCLUSIVE PROPERTY OF AMERICAN TOWER. THEIR USE AND PUBLICATION SHALL BE RESTRICTED TO THE ORIGINAL SITE FOR WHICH THEY ARE PREPARED. ANY USE OR DISCLOSURE OTHER THAN THAT WHICH RELATES TO AMERICAN TOWER OR THE SPECIFIED CARRIER IS STRICTLY PROHIBITED. TITLE TO THESE DOCUMENTS SHALL REMAIN THE PROPERTY OF AMERICAN TOWER WHETHER OR NOT THE PROJECT IS EXECUTED. NEITHER THE ARCHITECT NOR THE ENGINEER WILL BE PROVIDING ON-SITE CONSTRUCTION REVIEW OF THIS PROJECT. CONTRACTOR(S) MUST VERIFY ALL DIMENSIONS AND ADVISE AMERICAN TOWER OF ANY DISCREPANCIES. ANY PRIOR ISSUANCE OF THIS DRAWING IS SUPERSEDED BY THE LATEST VERSION ON FILE WITH AMERICAN TOWER.

REV.	DESCRIPTION	BY	DATE
0	FOR CONSTRUCTION	DB	09/09/20

ATC SITE NUMBER:
21275
 ATC SITE NAME:
CALVARY CHURCH NC
 SITE ADDRESS:
 503 CALVARY CHURCH ROAD
 SANFORD, NC 27332

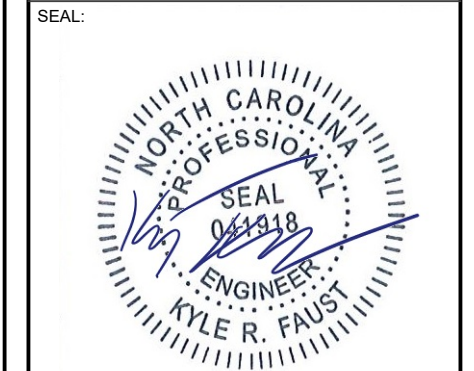

DRAWN BY:	DB
APPROVED BY:	MR
DATE DRAWN:	09/09/20
ATC JOB NO:	13320880_E2

ELECTRICAL ONE-LINE

SHEET NUMBER:	REVISION:
E-601	0

THIS DESIGN ONLY APPLICABLE TO 240V 1φ UTILITY SERVICE.
 FIELD VERIFY UTILITY SERVICE AND IF NOT 240V 1φ, HALT CONSTRUCTION AND RE-PROCESS FOR RE-DESIGN

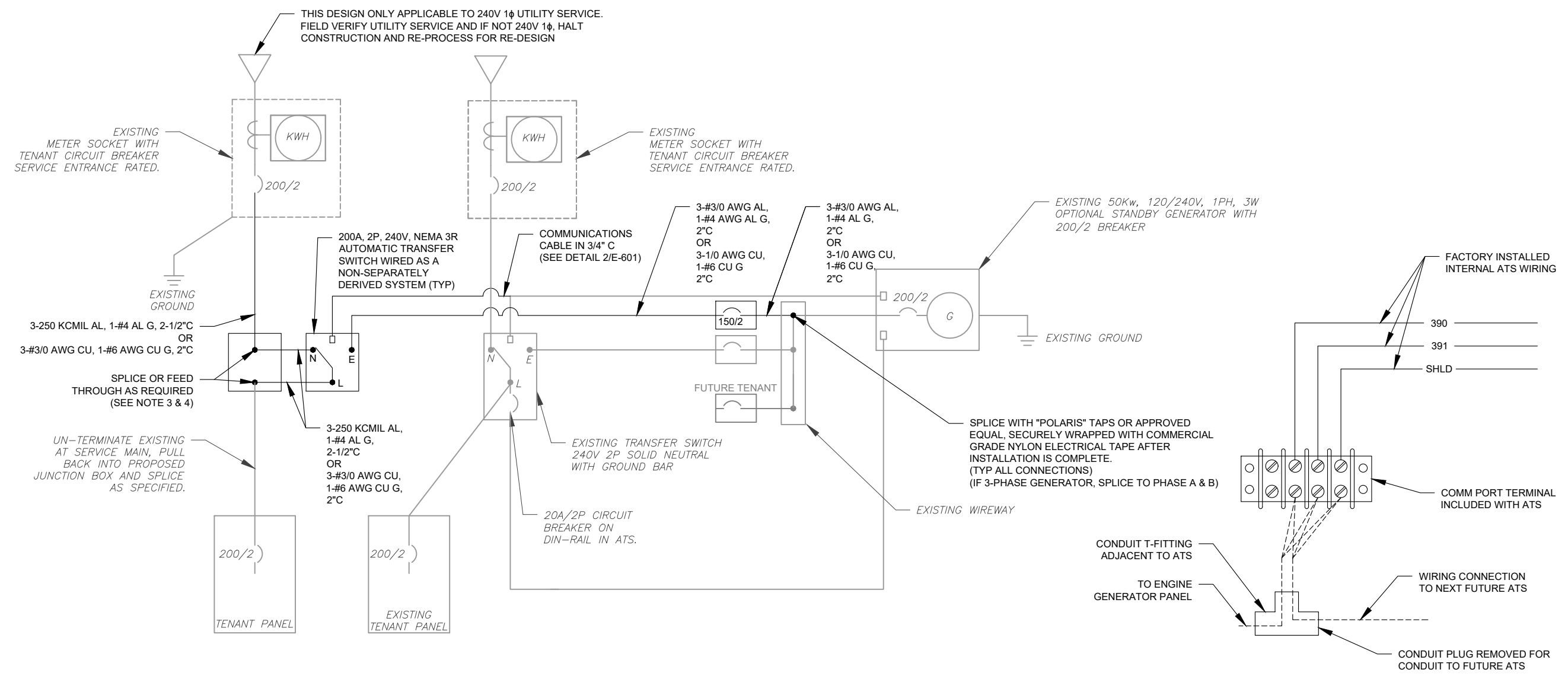

ONE-LINE NOTES:

- CONNECT CT'S PER HTS OWNERS MANUAL-SECTION 3.11.2 INSTRUMENT PACKAGE
- SPLICE WITH "POLARIS" TAPS OR APPROVED EQUAL, SECURELY WRAPPED WITH COMMERCIAL GRADE NYLON ELECTRICAL TAPE AFTER INSTALLATION IS COMPLETE.
- UTILIZE EXISTING ENCLOSURES FOR SPLICING (PER NEC 312.8) OR INSTALL NEW JUNCTION BOX AS APPLICABLE PER SITE CONDITIONS AND CODES. SIZE JUNCTION BOX AS PER NEC 314.28
- IF TAPPING AT TENANT EQUIPMENT, NO TAPS MAY BE MADE WITHIN THEIR EXISTING EQUIPMENT, INCLUDING PPC.
- ALL CONDUIT SIZES SHOWN ARE MINIMUMS.

NOTES:

- COMMUNICATION WIRING SHALL BE 2-CONDUCTOR WITH SHIELD, BELDEN #9460 OR EQUAL.
- COMMUNICATION WIRING SHALL BE INSTALLED IN SEPARATE CONDUITS FROM AC POWER AND CONTROL.
- CONNECT SHIELD, SHLD, AT EACH ATS, BUT DO NOT CONNECT THE SHIELD AT THE ENGINE GENERATOR.
- SET DIP SWITCHES IN ATS AS FOLLOWS, OR AS SUPERSEDED BY THE ATS INSTALLATION MANUAL:
 - DIP SWITCH 1
 - SWITCHES 1-3 AS PER INSTALLATION MANUAL PER VOLTAGE/PHASE OF SYSTEM.
 - SWITCH 6 ON FOR 3-PHASE, OFF FOR 1-PHASE.
 - SWITCH 7-8 TO ESTABLISH THE MODBUS ADDRESS OF THE ATS PER INSTALLATION MANUAL. 1ST ATS SHALL BE MODBUS ADDRESS 240, 2ND ADDRESS 241, 3RD ADDRESS 242, AND 4TH ADDRESS 243.
 - DIP SWITCH 2
 - SWITCH 1 ON FOR 60 HZ SYSTEM.
 - SWITCHES 2-6 NO FUNCTION.
 - SWITCHES 7-8 OFF-OFF FOR 4800 BAUD RATE.

1 ELECTRICAL ONE-LINE DIAGRAM
 SCALE: NOT TO SCALE

2 COMMUNICATIONS CABLE DETAIL
 SCALE: NOT TO SCALE

Copyright © 2020 ATC IP LLC. All Rights Reserved.