

03-5-7258R

HARNETT COUNTY HEALTH DEPARTMENT

No 19353

IMPROVEMENT PERMIT

Be it ordained by the Harnett County Board of Health as follows: Section III, Item B. "No Person shall begin construction of any building at which a septic tank system is to be used for disposal of sewage without first obtaining a written permit from the Harnett County Health Department."

Name: (owner) Myers Andersen Assoc.

New Installation  Septic Tank

Property Location: SR# 2005 Brickmill Rd.

Repairs  Nitrification Line

Subdivision Cottleston Lot # 9

Tax ID # \_\_\_\_\_ Quadrant # \_\_\_\_\_

Number of Bedrooms Proposed: 3 Lot Size: .58 Ac

Basement with Plumbing:  Garage:

Water Supply:  Well  Public  Community

Distance From Well: 50 min ft.

Following is the minimum specifications for sewage disposal system on above captioned property. Subject to final approval.

Type of system:  Conventional  Other \_\_\_\_\_

Size of tank: Septic Tank: 1000 gallons Pump Tank: \_\_\_\_\_ gallons

Subsurface Drainage Field No. of ditches 4 exact length of each ditch 60 ft. width of ditches 3 ft. depth of ditches 18-24 in.

French Drain Required: \_\_\_\_\_ Linear feet

Date: 6/30/2007

This permit is subject to revocation if site plans or intended use change.

Signed: Bryan M. Swain R.S.  
Environmental Health Specialist

\*Maintain all setbacks

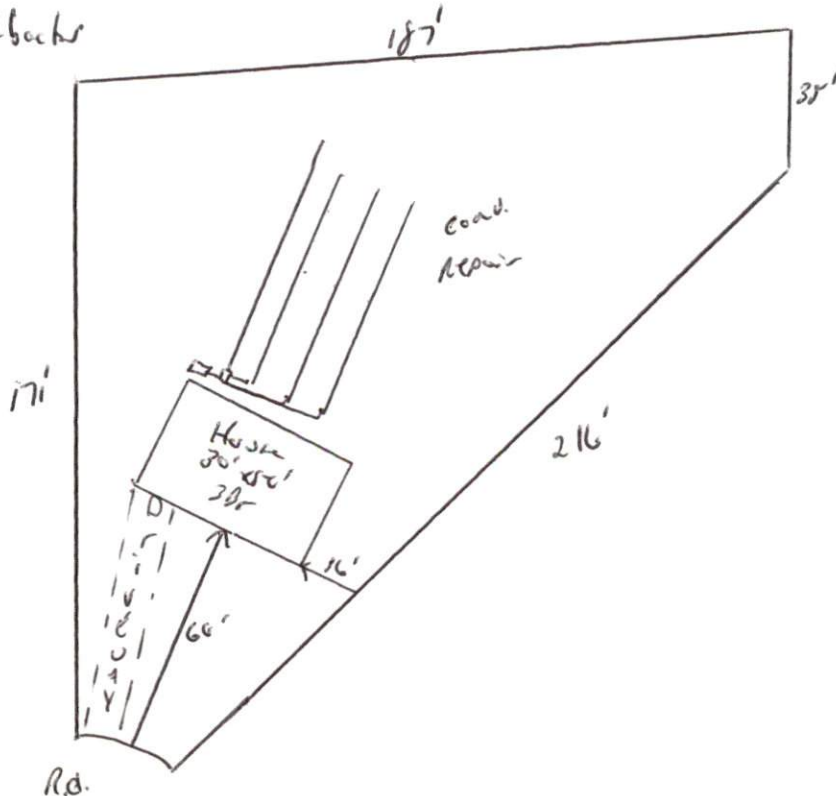

HARNETT COUNTY HEALTH DEPARTMENT  
AUTHORIZATION TO CONSTRUCT

Authorization is hereby given to construct a wastewater system to the specifications described by Harnett County Health Department, Improvement Permit # 19353. This authorization shall be valid for a period not to exceed five (5) years from the date of issuance. This authorization will be invalid if ownership, site plans, or intended use change.

Name Myers Anderson Ass. Telephone# 897-7775

Address P.O. Box 181 Erwin, N.C. 28329

Property Location SR# 2005 Road Name Brick Mill

Subdivision Cottleston Lot # 9 # Bedrooms Proposed 3 Lot Size .58 Ac

TYPE OF SYSTEM

New Installation  Repair  Septic Tank  Nitrification Lines

Conventional  Other \_\_\_\_\_

Basement  With Plumbing  Without Plumbing

Water Supply:  Well  Public Water Supply Minimum Well Setback: 50 Ft.

Septic Tank 1000 gal Pump Chamber \_\_\_\_\_ gal

NITRIFICATION FIELD SPECIFICATIONS

Number of fields 1 # of lines per field 4 Length of lines 60 Ft.

Width of ditches 3 ft. Depth of ditches 18-24 inches

French Drain: Linear feet required \_\_\_\_\_ Depth of gravel \_\_\_\_\_

No wastewater system shall be covered or placed into use by any person until an inspection by the Harnett County Health Department has determined that the system has been installed according to the conditions of the Improvement Permit and that a valid Operations Permit has been issued.

Signature of Authorized Agent for Harnett County of Harnett [Signature] Date 6/20/2003