

03-5-7173

# OPERATIONS PERMIT

Name: (owner) MOSS HOME BUILDERS     New Installation     Septic Tank  
 Property Location: SR# 1125 LEMUEL BLACK RD     Repairs     Nitrification Line  
 Subdivision \_\_\_\_\_ Lot # \_\_\_\_\_  
 TAX ID# \_\_\_\_\_ Quadrant # \_\_\_\_\_  
 Contractor: LONNIE JOHNSON    Registration # \_\_\_\_\_

Basement with Plumbing:     Garage:

Water Supply:  Well     Public     Community

Distance From Well: 100 ft.

**Following are the specifications for the sewage disposal system on above captioned property.**

Type of system:  Conventional     Other \_\_\_\_\_

Size of tank:    Septic Tank: 1000 gallons    Pump Tank: \_\_\_\_\_ gallons

Subsurface    No. of    exact length    width of    depth of  
 Drainage Field    ditches 3    of each ditch 80 ft.    ditches 3 ft.    ditches 18-22 in.

French Drain: \_\_\_\_\_ Linear feet

Date: 2/4/04

PERMIT NO. 20084

Inspected by: [Signature] RS  
Environmental Health Specialist

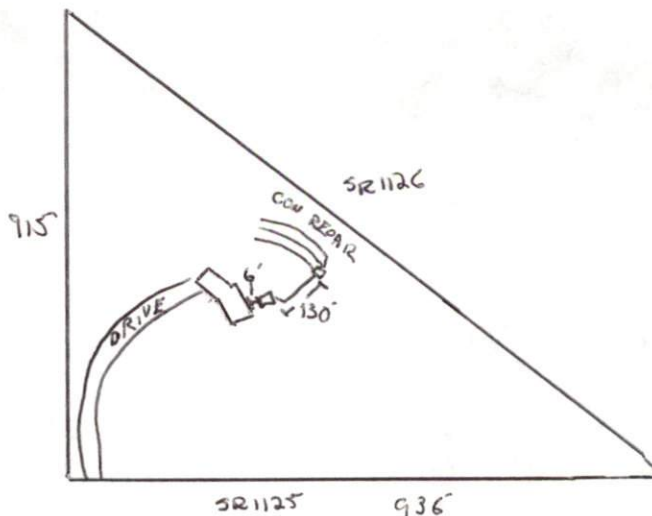

# OPERATIONS PERMIT

Property Location: \_\_\_\_\_  
 Subdivision: \_\_\_\_\_  
 Tax ID: \_\_\_\_\_  
 Registration: \_\_\_\_\_  
 New Installation  Repair  Other  
 Septic Tank  Other  
 Distance From Well: \_\_\_\_\_  
 Well  Ejecta  Community  Other

Following are the specifications for the sewage disposal system on above captioned property:

Type of system:  Conventional  Other \_\_\_\_\_  
 Size of tank: \_\_\_\_\_ gallons  
 Depth of \_\_\_\_\_  
 Distance from \_\_\_\_\_  
 French Drain: \_\_\_\_\_ inches  
 No. of \_\_\_\_\_  
 exact length \_\_\_\_\_  
 of each \_\_\_\_\_  
 diameter \_\_\_\_\_  
 depth of \_\_\_\_\_

PERMIT NO. \_\_\_\_\_  
 Date: \_\_\_\_\_  
 Inspector: \_\_\_\_\_  
 Environmental Health Specialist

