

APPLICANT NAME _____

DATE _____

FACTORS		PROFILES								
		1	2	3	4	5	6	7	8	9
LANDSCAPE POSITION	.1940	L	L	L	L					
SLOPE (%)	.1940	4	3	4	3					
HORIZON 1 DEPTH		0-18	0-20	0-18	6-20					
Texture Group	.1941(A)(1)	SL			SL					
Consistence	.1941	PK			PK					
Structure	.1941(A)(2)	GL			GL					
Mineralogy	.1941(A)(3)	NSNP			NSNP					
HORIZON 2 DEPTH		18-24			20-30					
Texture Group	.1941(A)(1)	SL			SL					
Consistence	.1941	PK			PK					
Structure	.1941(A)(2)	GL			GL					
Mineralogy	.1941(A)(3)	SSP			SSP					
HORIZON 3 DEPTH		29-36			30-42					
Texture Group	.1941(A)(1)	SL-CL			SL-CL					
Consistence	.1941	PK			PK					
Structure	.1941(A)(2)	GL			GBL					
Mineralogy	.1941(A)(3)	SSP			SSP					
HORIZON 4 DEPTH										
Texture Group	.1941(A)(1)									
Consistence	.1941									
Structure	.1941(A)(2)									
Mineralogy	.1941(A)(3)									
SOIL WETNESS	.1942	32	34	32	34					
RESTRICTIVE HORIZON	.1944									
SAPROLITE	.1943/1956									
CLASSIFICATION	.1948	P1	P2	P2	P3					
LONG TERM ACCEPTANCE RATE	.1955	.4	.4	.4	.4					

TERRACE Ridge Built for Farm fields
 parent material left soil there.

- NOTES:
 1) THIS MAP IS THE RESULT OF A SURVEY, INFORMATION TAKEN FROM REFERENCE MATERIALS.
 2) PROPERTY SUBJECT TO ALL EASEMENTS AND RESTRICTIONS OF RECORD.
 3) NO DETERMINATION HAS BEEN MADE AS TO THE EXISTENCE OF FEMA FLOOD HAZARD AREAS ON THIS PARCEL.
 4) THIS PLAT NOT FOR RECORDING, CONVEYANCES, OR SALES.

Required Property Line Setbacks

Front	Minimum 35'	Actual 35'
Side	10'	58'
Corner		
Rear	25'	
Nearest Building	10'	

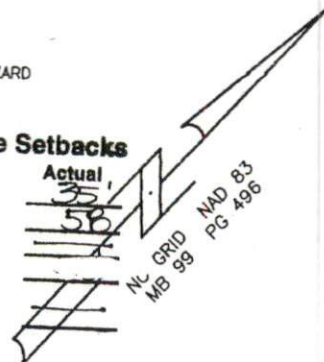

SITE PLAN APPROVAL

DISTRICT RA30 USE SFD

BEDROOMS 3

Date 10-18-00 D. Johnson
 Zoning Administrator

NOW OR FORMERLY
 PAUL JOHNSON
 DB 681 PG 1-3

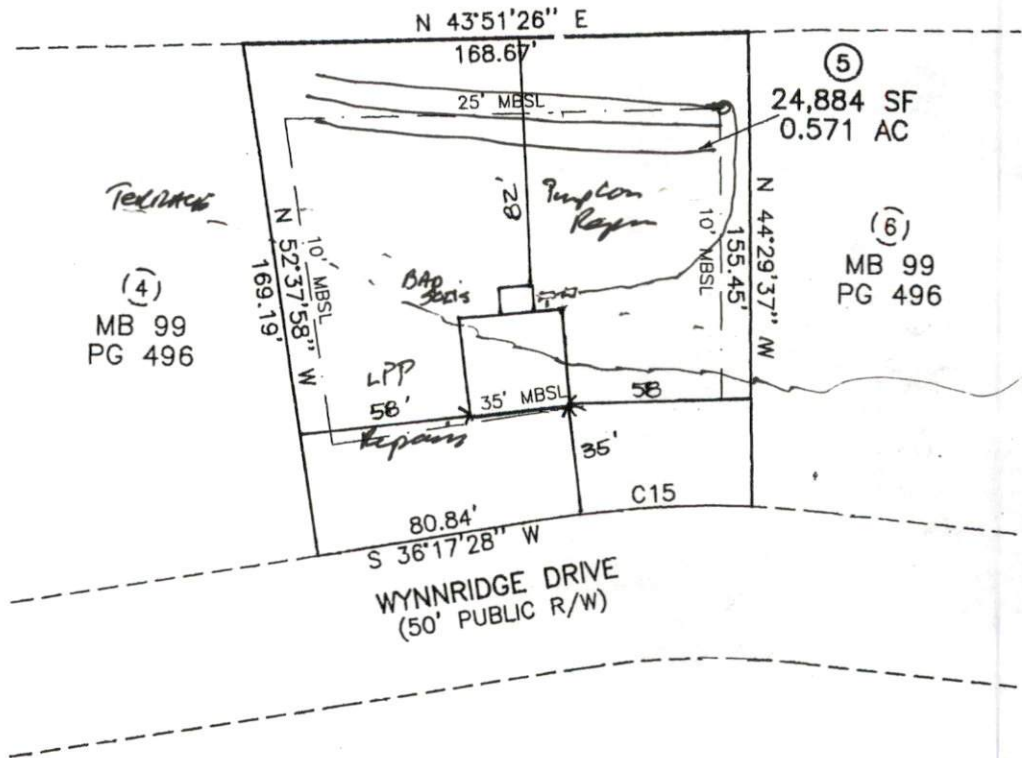

NUMBER	CHORD BEARING	RADIUS	ARC	CHORD
C15	S 42°01'39" W	325.00	65.08	64.97

I, PETER J. BRENNAN, JR. CERTIFIED SURVEYOR
 DRAWN FROM AN ACTUAL SURVEY UNDER MY PERSONAL SUPERVISION, THAT THE ERROR OF THIS SURVEY IS 1:10,000+, THAT THE BOUNDARIES SHOWN AS BROKEN LINES.

- REGISTRATION NUMBER L-3743
- LEGEND**
- EP EXISTING IRON PIN
 - IPS IRON PIN SET
 - RRS RAILROAD SPIKE
 - EPKN EXISTING PARKER-KALON NAIL
 - PKNS PARKER-KALON NAIL SET
 - CP COMPUTED POINT
 - LINES NOT SURVEYED

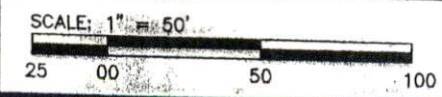

NOT PREPARED FOR RECORDATION

DRAWN: JAH DATE: 09/30/99 CHECKED: PJB

PLOT PLAN FOR
DESS LANGDON
 LOT 5 WYNNRIDGE SUBDIVISION
 GROVE TOWNSHIP HARNETT COUNTY NORTH CAROLINA

LEWIS, BRENNAN & ASSOCIATES
 SURVEYORS, P.A.
 305 EAST MAIN STREET
 CLAYTON, N.C., 27520
 TELEPHONE: (919) 553-5100
 FAX: (919) 553-2216