

09/09/11,

Application #

43595

Harnett County Central Permitting

PO Box 65 Lillington NC 27546

910 893 7525 Fax 910 893 2793 www.harnett.org/permits

Each section below to be filled out by whomever performing work Must be owner or licensed contractor Address company name & phone must match

Application for Residential Building and Trades Permit

Owner's Name Chris King Date 3/20/18
Site Address 265 Hester PL Phone 919 449 8783
Directions to job site from Lillington NUISERY RD to 87 to R at Northridge Plantation

Subdivision North Ridge Plantation Lot
Description of Proposed Work # of Bedrooms
Heated SF Unheated SF Finished Bonus Room? Crawl Space Slab

General Contractor Information

LANDSEAR pros 919 360 0797
Building Contractor's Company Name Telephone
1530 Clark RD Address Email Address
License #

Electrical Contractor Information

Description of Work pool electrical Service Size Amps T-Pole Yes No
Culbertson Electric (910) 723 3293
Electrical Contractor's Company Name Telephone
302 Lennox Loop Relford NC Address Email Address
266 27-L License #

Mechanical/HVAC Contractor Information

Description of Work
Mechanical Contractor's Company Name Telephone
Address Email Address
License #

Plumbing Contractor Information

Description of Work # Baths
Plumbing Contractor's Company Name Telephone
Address Email Address
License #

Insulation Contractor Information

Insulation Contractor's Company Name & Address Telephone

\*NOTE General Contractor must fill out and sign the second page of this application

I hereby certify that I have the authority to make necessary application that the application is correct and that the construction will conform to the regulations in the Building Electrical Plumbing and Mechanical codes and the Harnett County Zoning Ordinance I state the information on the above contractors is correct as known to me and that by signing below I have obtained all subcontractors permission to obtain these permits and if any changes occur including listed contractors site plan number of bedrooms building and trade plans Environmental Health permit changes or proposed use changes I certify it is my responsibility to notify the Harnett County Central Permitting Department of any and all changes

**EXPIRED PERMIT FEES** - 6 Months to 2 years permit re-issue fee is \$150 00 After 2 years re-issue fee is as per current fee schedule

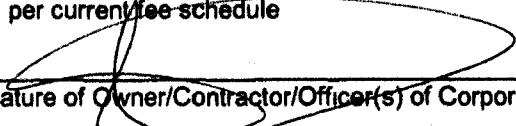
  
Signature of Owner/Contractor/Officer(s) of Corporation

3 20 18  
Date

**Affidavit for Worker's Compensation N C G S 87-14**

The undersigned applicant being the

General Contractor     Owner     Officer/Agent of the Contractor or Owner

Do hereby confirm under penalties of perjury that the person(s) firm(s) or corporation(s) performing the work set forth in the permit

Has three (3) or more employees and has obtained workers compensation insurance to cover them

Has one (1) or more subcontractors(s) and has obtained workers compensation insurance to cover them

Has one (1) or more subcontractors(s) who has their own policy of workers compensation insurance covering themselves

Has no more than two (2) employees and no subcontractors

While working on the project for which this permit is sought it is understood that the Central Permitting Department issuing the permit may require certificates of coverage of worker s compensation insurance prior to issuance of the permit and at any time during the permitted work from any person firm or corporation carrying out the work

Company or Name Landscare Pros

Sign w/Title  Date 3/20/18

Initial Application Date: 3/20/18

Application # 1850043595

CU# \_\_\_\_\_

**COUNTY OF HARNETT RESIDENTIAL LAND USE APPLICATION**  
Central Permitting 108 E. Front Street, Lillington, NC 27546 Phone: (910) 893-7525 ext:2 Fax: (910) 893-2793 **SCANNED** Permits

**\*\*A RECORDED SURVEY MAP, RECORDED DEED (OR OFFER TO PURCHASE) & SITE PLAN ARE REQUIRED WHEN SUBMITTING A LAND USE APPLICATION\*\***

LANDOWNER: Jenny King & Christopher Mailing Address: 265 Hester PL  
City: Cameron State: NC Zip: 28326 Contact No: (919) 449 8783 Email: \_\_\_\_\_

APPLICANT\*: Landscape pros Mailing Address: 2651530 Clark Rd  
City: Lillington State: NC Zip: 27546 Contact No: (919) 360 0797 Email: \_\_\_\_\_

\*Please fill out applicant information if different than landowner

CONTACT NAME APPLYING IN OFFICE: Adam Phone # (919) 360 0797

PROPERTY LOCATION: Subdivision: Richmond Park @ Northridge Plantation Lot #: 236 Lot Size: .49

State Road # \_\_\_\_\_ State Road Name: 265 Hester PL Map Book & Page: 2007, 369

Parcel: 09956506 0282 08 PIN: 9595-02-2356-000

Zoning: A-20R Flood Zone: X Watershed: NO Deed Book & Page: 2517, 436 Power Company\*: \_\_\_\_\_

\*New structures with Progress Energy as service provider need to supply premise number \_\_\_\_\_ from Progress Energy.

**PROPOSED USE:**

- SFD: (Size \_\_\_\_\_ x \_\_\_\_\_) # Bedrooms: \_\_\_\_\_ # Baths: \_\_\_\_\_ Basement (w/wo bath): \_\_\_\_\_ Garage: \_\_\_\_\_ Deck: \_\_\_\_\_ Crawl Space: \_\_\_\_\_ Slab: \_\_\_\_\_ Slab: \_\_\_\_\_  
(Is the bonus room finished? ( ) yes ( ) no w/ a closet? ( ) yes ( ) no (if yes add in with # bedrooms) Monolithic
- Mod: (Size \_\_\_\_\_ x \_\_\_\_\_) # Bedrooms \_\_\_\_\_ # Baths \_\_\_\_\_ Basement (w/wo bath) \_\_\_\_\_ Garage: \_\_\_\_\_ Site Built Deck: \_\_\_\_\_ On Frame \_\_\_\_\_ Off Frame \_\_\_\_\_  
(Is the second floor finished? ( ) yes ( ) no Any other site built additions? ( ) yes ( ) no
- Manufactured Home: \_\_\_\_\_ SW \_\_\_\_\_ DW \_\_\_\_\_ TW (Size \_\_\_\_\_ x \_\_\_\_\_) # Bedrooms: \_\_\_\_\_ Garage: \_\_\_\_\_ (site built? \_\_\_\_\_) Deck: \_\_\_\_\_ (site built? \_\_\_\_\_)
- Duplex: (Size \_\_\_\_\_ x \_\_\_\_\_) No. Buildings: \_\_\_\_\_ No. Bedrooms Per Unit: \_\_\_\_\_
- Home Occupation: # Rooms: \_\_\_\_\_ Use: \_\_\_\_\_ Hours of Operation: \_\_\_\_\_ #Employees: \_\_\_\_\_
- Addition/Accessory/Other: (Size 18 x 34) Use: Inground pool Closets in addition? ( ) yes (X) no

Water Supply:  County \_\_\_\_\_ Existing Well \_\_\_\_\_ New Well (# of dwellings using well \_\_\_\_\_) \*Must have operable water before final

Sewage Supply: \_\_\_\_\_ New Septic Tank (Complete Checklist) \_\_\_\_\_ Existing Septic Tank (Complete Checklist)  County Sewer

Does owner of this tract of land, own land that contains a manufactured home within five hundred feet (500') of tract listed above? ( ) yes  no

Does the property contain any easements whether underground or overhead ( ) yes  no

Structures (existing or proposed): Single family dwellings:  Manufactured Homes: \_\_\_\_\_ Other (specify): \_\_\_\_\_

**Required Residential Property Line Setbacks:**

Front	Minimum	Actual
Rear	<u>25'</u>	<u>45'</u>
Closest Side	<u>10'</u>	<u>70'</u>
Sidestreet/corner lot	_____	_____
Nearest Building on same lot	_____	_____

Comments: \_\_\_\_\_

SPECIFIC DIRECTIONS TO THE PROPERTY FROM LILLINGTON: 27 to Nursery RD to 87 Down to  
Light at Northridge plantation RIGHT TO LEFT on Hester pl

If permits are granted I agree to conform to all ordinances and laws of the State of North Carolina regulating such work and the specifications of plans submitted. I hereby state that foregoing statements are accurate and correct to the best of my knowledge. Permit subject to revocation if false information is provided.

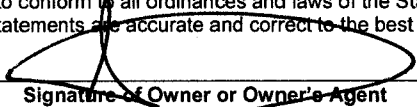
  
\_\_\_\_\_  
Signature of Owner or Owner's Agent

3 20 18  
Date

**\*\*\*It is the owner/applicants responsibility to provide the county with any applicable information about the subject property, including but not limited to: boundary information, house location, underground or overhead easements, etc. The county or its employees are not responsible for any incorrect or missing information that is contained within these applications.\*\*\***

**\*\*This application expires 6 months from the initial date if permits have not been issued\*\***

HARNETT COUNTY CENTRAL PERMITTING

P.O. BOX 65

LILLINGTON, NC 27546

For Inspections Call: (910) 893-7525 Fax: (910) 893-2793

Application Number . . . . .	18-50043595	Page	2
Property Address . . . . .	91750 TECH 3	Date	3/20/18
PARCEL NUMBER . . . . .	- - - - -		
Application description . . .	CP SWIMMING POOL		
Subdivision Name . . . . .			
Property Zoning . . . . .	UNZONED		

Required Inspections

Seq	Phone Insp#	Insp Code	Description	Initials	Date
Permit type . . . . . RESIDENTIAL BUILDING PERMIT					
999	103	B103	R*BLDG FOUND & TEMP SVC POLE	_____	___/___/___
999	111	B111	R*BLDG SLAB INSP/TEMP SVC POLE	_____	___/___/___
999	205	E205	R*ELEC UNDER SLAB	_____	___/___/___
999	213	E213	R*ELECTRICAL UNDERGROUND	_____	___/___/___
999	820	Z820	PZ*ZONING/FINAL INSPECTION	_____	___/___/___
999	101	B101	R*BLDG FOOTING / TEMP SVC POLE	_____	___/___/___
999	131	R131	ONE TRADE FINAL	_____	___/___/___
999	125	R125	ONE TRADE ROUGH IN	_____	___/___/___
999	229	R229	TWO TRADE FINAL	_____	___/___/___
999	225	R225	TWO TRADE ROUGH IN	_____	___/___/___
Permit type . . . . . LAND USE PERMIT					
999	818	Z818	PZ*ZONING INSPECTION	_____	___/___/___
999	820	Z820	PZ*ZONING/FINAL INSPECTION	_____	___/___/___



# Harnett GIS



GIS/E-911 Addressing

March 20, 2018

- Recycle Center
- Landfills
- Surrounding County Boundaries
- Federal Property
- City Limits
- Address Numbers
- Airport
- Major Roads
- Interstate
- NC
- US
- Roads
- Mile\_Markers
- Railroad
- Parcels

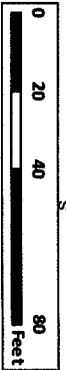

1 inch = 47 feet

STANDARD PANEL LAYOUT

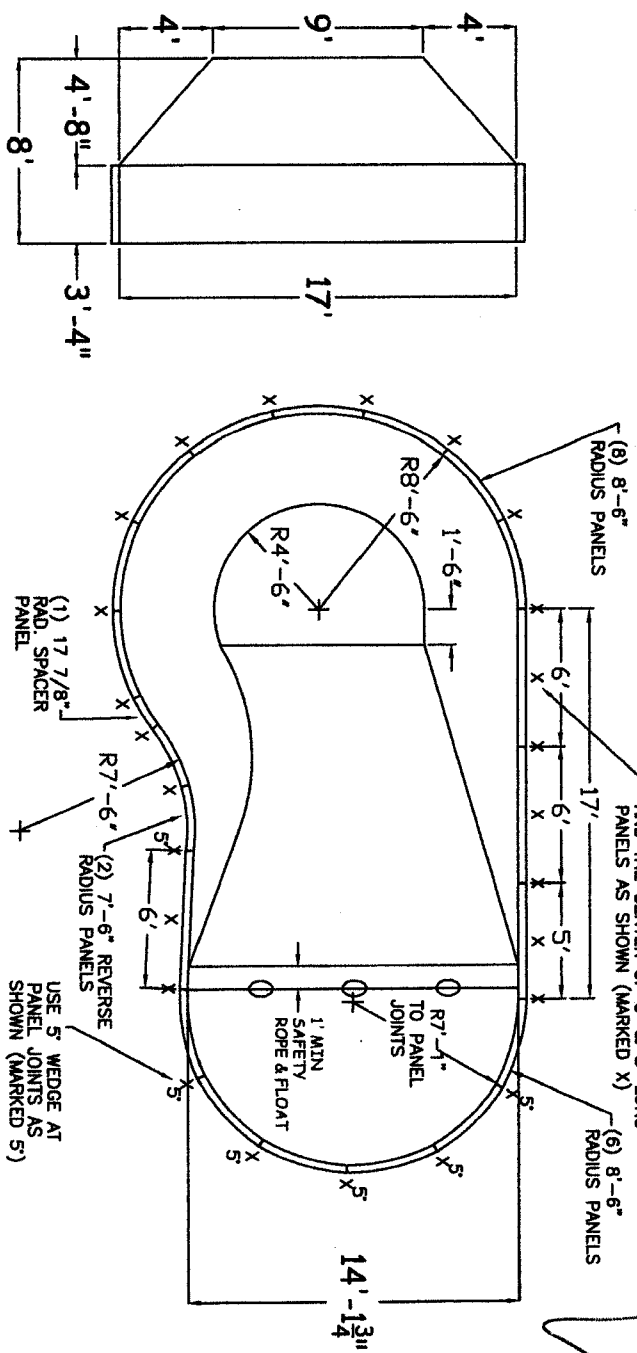

STEP OPTIONS

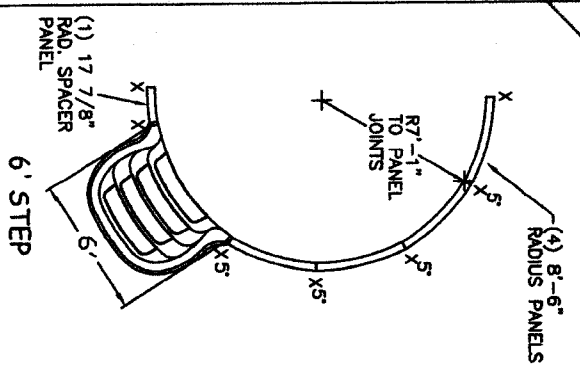

GRAPHHEX

17' x 33' OBLIQUE LEFT

GRAPHHEX 2310

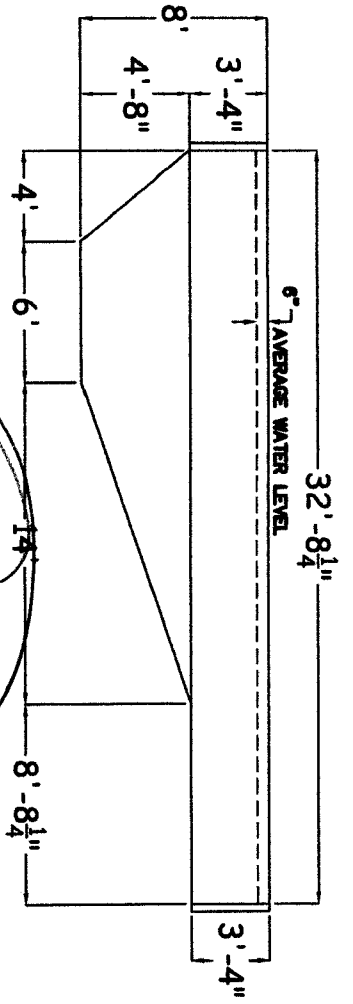

PART#: CB00S1733

SURFACE AREA: (ft<sup>2</sup>): 446

PERIMETER: 83'-11"

VOLUME (US Gal): 16,909



MEETS DEPTH AND SHAPE MINIMUM STANDARD ANSI/APSP/ICC-5-2011

DWG#: GXCB00S1733L13

SHEET: 1 OF 3

DATE: 01/01/13

LINER AREA (ft<sup>2</sup>): 561

VOLUME (Litres): 61,736

ALWAYS ENTER POOL DIVING/SLIDING EQUIPMENT SHALL BE DESIGNED FOR SWIMMING POOLS AND SHALL BE INSTALLED IN ACCORDANCE WITH THE DIVING/SLIDING EQUIPMENT MANUFACTURER'S SPECIFICATIONS. PLEASE CONTACT THE DIVING/SLIDING EQUIPMENT MANUFACTURER FOR THEIR SPECIFICATIONS.

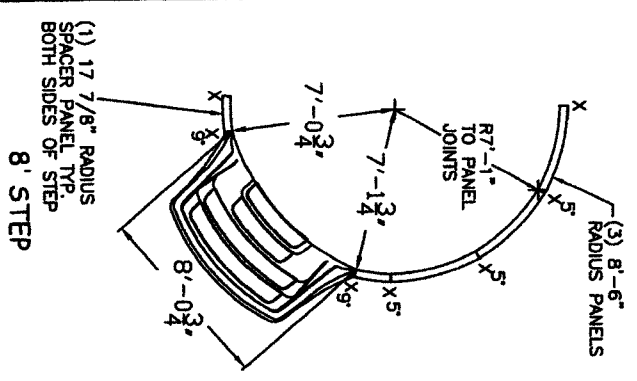

OBLIQUE



HARNETT COUNTY CASH RECEIPTS

\*\*\* CUSTOMER RECEIPT \*\*\*

Oper: LLUCAS      Type: CP    Drawer: 1  
Date: 3/20/18 53    Receipt no: 294995

Year	Number	Amount
2018	50043595	
91750 TECH 3		
LILLINGTON, NC 27546		
E1	BP - PERMIT FEES	\$125.00

LANDSCAPE PROS

Tender detail		
CK CHECK PAYMEN	1260	\$125.00
Total tendered		\$125.00
Total payment		\$125.00

Trans date: 3/20/18      Time: 9:31:41

\*\* THANK YOU FOR YOUR PAYMENT \*\*