

ADDRESS : 31 FARRAH-SHEA WAY  
CONTRACTOR : CUMBERLAND HOMES INC  
OWNER : CUMBERLAND HOMES INC  
PARCEL : 04-0662- - -0024- -27-  
APPL NUMBER: 15-50036954 CP NEW RESIDENTIAL (SFD)  
DIRECTIONS : T/S: 08/24/2015 04:13 PM JBROCK ----  
BRIAN KEITH MEADOW #23

SUBDIV: BRIAN KEITH MEADOW 25LOTS  
PHONE : (910) 892-4345  
PHONE :

STRUCTURE: 000 000 47X55 3BDR SLAB W/ GARAGE & PATIO

FLOOD ZONE : FLOOD ZONE X  
# BEDROOMS : 3000000.00  
SEPTIC - EXISTING? : NEW TANK  
PROPOSED USE : SFD  
WATER SUPPLY : COUNTY

PERMIT: CPSF 00 CP \* SFD

TYP/SQ	REQUESTED COMPLETED	INSP RESULT	DESCRIPTION RESULTS/COMMENTS
B101 01	10/22/15	BS	R*BLDG FOOTING / TEMP SVC POLE TIME: 17:00 VRU #: 002733392
	10/22/15	AP	T/S: October 22, 2015 03:51 PM BSUTTON
A814 01	10/30/15	SB	ADDRESS CONFIRMATION TIME: 17:00 VRU #: 002736783
	10/30/15	AP	31 FARRAH-SHEA WAY ANGIER 27501 T/S: 10/30/2015 09:35 AM SBENNETT
B103 01	10/30/15	BS	R*BLDG FOUND & TEMP SVC POLE TIME: 17:00 VRU #: 002736775
	10/30/15	CA	T/S: October 30, 2015 11:30 AM BSUTTON
B103 02	11/02/15	BS	R*BLDG FOUND & TEMP SVC POLE TIME: 17:00 VRU #: 002737179
	11/02/15	AP	T/S: November 02, 2015 03:07 PM BSUTTON
P309 01	11/09/15	BS	R*PLUMB UNDER SLAB TIME: 17:00 VRU #: 002738862
	11/09/15	AP	T/S: 11/06/2015 10:21 AM DJOHNSON
			T/S: November 09, 2015 03:18 PM BSUTTON
B111 01	11/20/15	TI	R*BLDG SLAB INSP/TEMP SVC POLE TIME: 17:00 VRU #: 002743870
	<u>11/20/15</u>	<u>APB</u>	T/S: 11/19/2015 11:14 AM LBENNETT

COMMENTS AND NOTES



# Enoch Engineers, P.A.

Materials & Tests Division  
1403 NC Highway 50 South  
Benson, NC 27504  
919-894-7765

## Daily Report

Client: CUMBERLAND HOMES  
Project: BRIAN - KEITH MEADOWS S/O  
Location: 31 FARRAH-SHEA WAY  
Lot #: 23

Technician: BH  
Date: 11.18.15  
Contractor: C/O DENNIS NORRIS

### Services Performed:

- Soil Tests
- Concrete Tests
- Asphalt Tests
- Site Inspection
- Foundation Inspection
- Structural Inspection
- Proof-roll

- Steel Inspection
- Meeting
- Other
- Subgrade Inspection

Remarks: PERFORMED NOT ON PAD AT LOT NOTED ABOVE USING A  
TARGET DENSITY OF 110 PCF, SOILS CONFIRMED A COMPACTION  
≥ 95%.

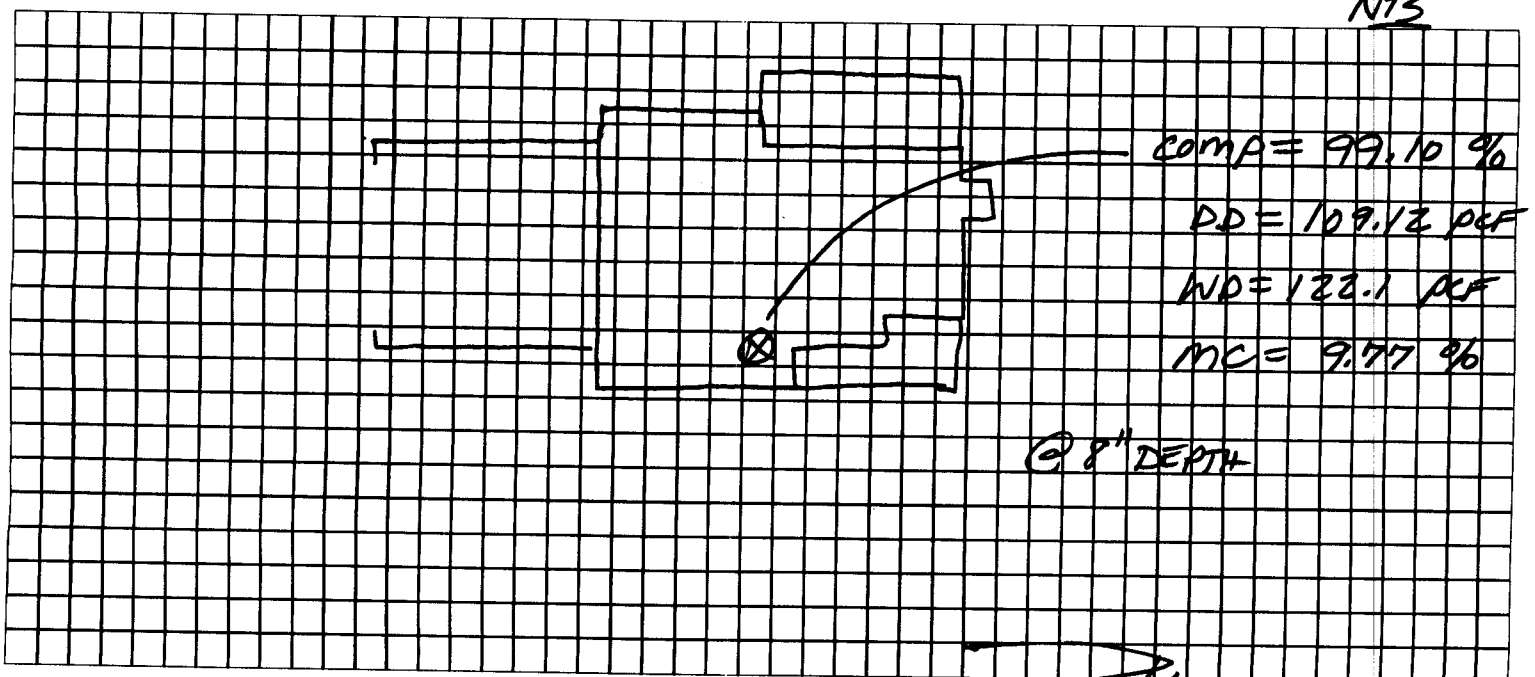

Technician: BH



ADDRESS . . : 109 FARRAH-SHEA WAY  
CONTRACTOR : CUMBERLAND HOMES INC  
OWNER . . . : BARCO DEVELOPMENT INC  
PARCEL . . . : 04-0662- - -0024- -06-  
APPL NUMBER: 15-50036675 CP NEW RESIDENTIAL (SFD)  
DIRECTIONS : T/S: 07/21/2015 08:43 AM JBROCK ----  
BRIAN KIETH MEADOW #2

SUBDIV: BRIAN KEITH MEADOW 25LOTS  
PHONE : (910) 892-4345  
PHONE :

STRUCTURE: 000 000 62X64 3BDR SLAB W/ GARAGE & PATIO

FLOOD ZONE . . . . : FLOOD ZONE X  
# BEDROOMS . . . . : 3000000.00  
SEPTIC - EXISTING? . . . . : NEW TANK  
PROPOSED USE . . . . . : SFD  
WATER SUPPLY . . . . . : COUNTY

PERMIT: CPSF 00 CP \* SFD

TYP/SQ	REQUESTED COMPLETED	INSP RESULT	DESCRIPTION RESULTS/COMMENTS
B101 01	10/22/15	BS	R*BLDG FOOTING / TEMP SVC POLE TIME: 17:00 VRU #: 002733384
	10/22/15	AP	T/S: October 22, 2015 03:51 PM BSUTTON
A814 01	11/02/15	SB	ADDRESS CONFIRMATION TIME: 17:00 VRU #: 002737096
	11/02/15	AP	109 FARRAH-SHEA WAY ANGIER 27501 T/S: 11/02/2015 08:59 AM SBENNETT
B103 01	11/02/15	BS	R*BLDG FOUND & TEMP SVC POLE TIME: 17:00 VRU #: 002737088
	11/02/15	AP	T/S: November 02, 2015 03:07 PM BSUTTON
P309 01	11/17/15	DT	R*PLUMB UNDER SLAB TIME: 17:00 VRU #: 002741890
	11/17/15	AP	T/S: 11/16/2015 10:21 AM LBENNETT CUSTOMER WOULD LIKE TSP ALSO T/S: 11/17/2015 01:19 PM DETAYLOR
B111 01	11/20/15	TI	R*BLDG SLAB INSP/TEMP SVC POLE TIME: 17:00 VRU #: 002743862
	<u>11-20-15</u>	<u>APBS</u>	T/S: 11/19/2015 11:14 AM LBENNETT

COMMENTS AND NOTES

# Enoch Engineers, P.A.

Materials & Tests Division  
1403 NC Highway 50 South  
Benson, NC 27504  
919-894-7765

## Daily Report

Client: CUMBERLAND HOMES  
Project: BRIAN-KEITH MEADOWS S/D  
Location: 109 FALLAH-SHEA WAY  
Lot #: 2

Technician: BH  
Date: 11.18.15  
Contractor: CO DENNIS NARRIS

### Services Performed:

- Soil Tests
- Concrete Tests
- Asphalt Tests
- Site Inspection
- Foundation Inspection
- Structural Inspection
- Proof-roll

- Steel Inspection
- Meeting
- Other
- Subgrade Inspection

Remarks: PERFORMED NOT ON PAD AT LOT NOTED ABOVE USING  
A TARGET DENSITY OF 110 PCF. SOILS CONFIRMED A COMPACTION  
≥ 95%.

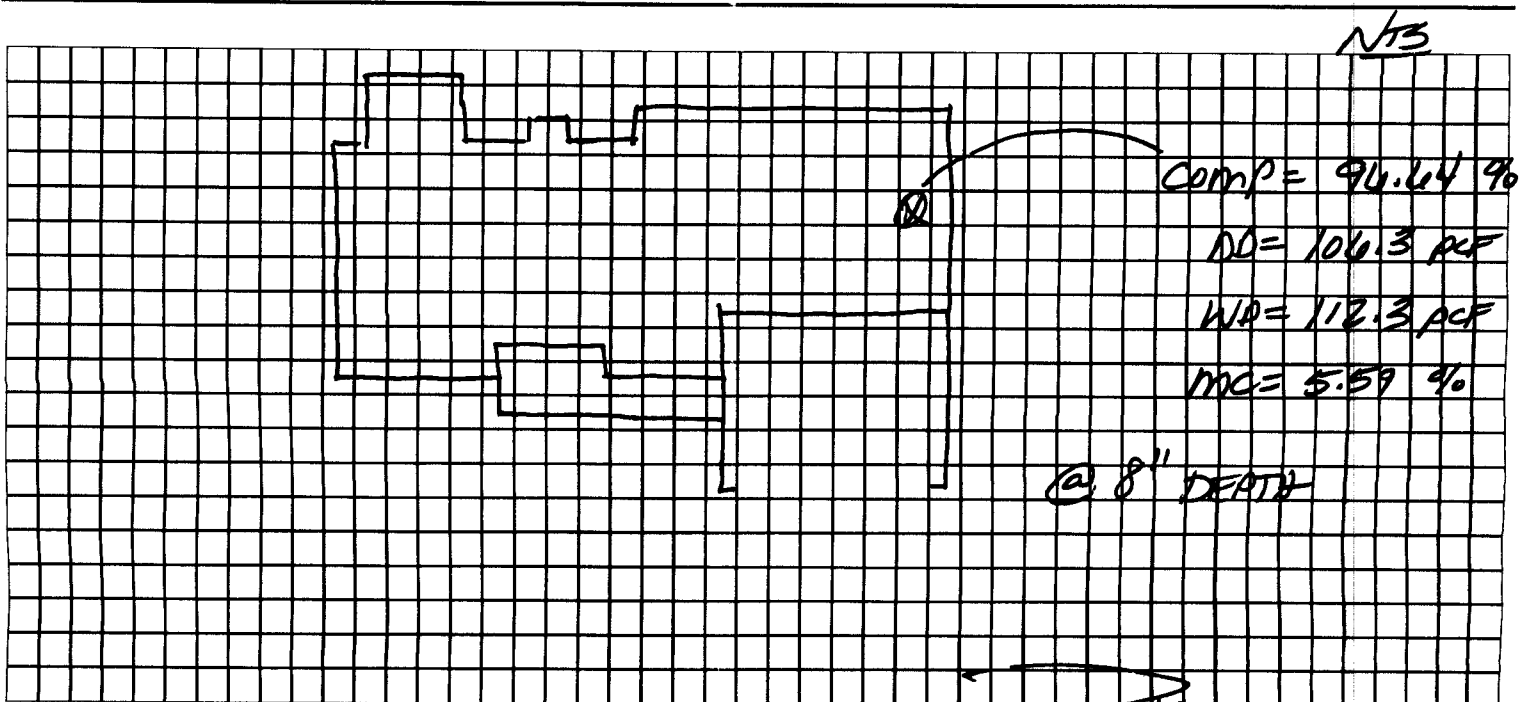

Technician: BH

