

HTE# 15-5-36630R

# Harnett County Department of Public Health

28795

## Improvement Permit

A building permit cannot be issued with only an Improvement Permit

ISSUED TO: CASES BUILDING INC PROPERTY LOCATION: JUNO DRIVE  
 SUBDIVISION: TINGEN POINTE LOT # 152A  
 NEW  REPAIR  EXPANSION   
 Type of Structure: SFD (41x47) Site Improvements required prior to Construction Authorization Issuance: \_\_\_\_\_  
 Proposed Wastewater System Type: Pump To 25% Reduction  
 Projected Daily Flow: 360 GPD  
 Number of bedrooms: 3 Number of Occupants: 6 max  
 Basement  Yes  No  
 Pump Required:  Yes  No  May be required based on final location and elevations of facilities  
 Type of Water Supply:  Community  Public  Well Distance from well 100 feet Permit valid for:  Five years  
 No expiration  
 Permit conditions: \_\_\_\_\_

Authorized State Agent: [Signature] Date: 4/29/16 SEE ATTACHED SITE SKETCH  
 The issuance of this permit by the Health Department in no way guarantees the issuance of other permits. The permit holder is responsible for checking with appropriate governing bodies in meeting their requirements. This site is subject to revocation if the site plan, plat, or the intended use changes. The Improvement Permit shall not be affected by a change in ownership of the site. This permit is subject to compliance with the provisions of the Laws and Rules for Sewage Treatment and Disposal and to conditions of this permit.

## Construction Authorization

(Required for Building Permit)

The construction and installation requirements of Rules .1950, .1952, .1954, .1955, .1956, .1957, .1958, and .1959 are incorporated by references into this permit and shall be met. Systems shall be installed in accordance with the attached system layout.

ISSUED TO: CASES BUILDING INC PROPERTY LOCATION: JUNO DRIVE  
 SUBDIVISION: TINGEN POINTE LOT # 152A  
 Facility Type: SFD (41x47)  New  Expansion  Repair  
 Basement?  Yes  No Basement Fixtures?  Yes  No  
 Type of Wastewater System\*\* Pump To 25% Reduction System (Initial) Wastewater Flow: 360 GPD  
 (See note below, if applicable ) Pump To 25% Red. (Repair)

**Installation Requirements/Conditions**  
 Septic Tank Size 1000 gallons Exact length of each trench 190 feet Trench Spacing: 9 Feet on Center  
 Pump Tank Size 1000 gallons Trenches shall be installed on contour at a Soil Cover: 6 inches  
 Maximum Trench Depth of: 18 inches (Maximum soil cover shall not exceed 36" above the trench bottom)  
 (Trench bottoms shall be level to +/-1/4" in all directions)  
 Pump Requirements: \_\_\_\_\_ ft. TDH vs. \_\_\_\_\_ GPM \_\_\_\_\_ inches below pipe  
 Aggregate Depth: \_\_\_\_\_ inches above pipe  
 Conditions: PERMIT BASED ON PROPOSAL FROM APPLICANTS LSS \_\_\_\_\_ inches total

**WATER LINES (INCLUDING IRRIGATION) MUST BE 10FT. FROM ANY PART OF SEPTIC SYSTEM OR REPAIR AREA.  
NO UTILITIES ALLOWED IN INITIAL OR REPAIR DRAIN FIELD AREA.**

\*\*If applicable: I understand the system type specified is different from the type specified on the application. I accept the specifications of this permit.  
 Owner/Legal Representative Signature: \_\_\_\_\_ Date: \_\_\_\_\_

This Construction Authorization is subject to revocation if the site plan, plat, or the intended use changes. The Construction Authorization shall not be transferred when there is a change in ownership of the site. This Construction Authorization is subject to compliance with the provisions of the Laws and Rules for Sewage Treatment and Disposal and to the conditions of this permit. SEE ATTACHED SITE SKETCH

Authorized State Agent: [Signature] Date: 4/29/16  
 Construction Authorization Expiration Date: 4/29/21

HTE# 15-5-36630R

Permit # 28795

# Harnett County Department of Public Health Site Sketch

ISSUED TO: CATES BUILDING INC PROPERTY LOCATOR: JUNO DRIVE  
SUBDIVISION TINGEN POINTE LOT # 152A

Authorized State Agent: ~~[Signature]~~ [Signature] (LOWERY TOXSOUSE) Date: 4/29/16

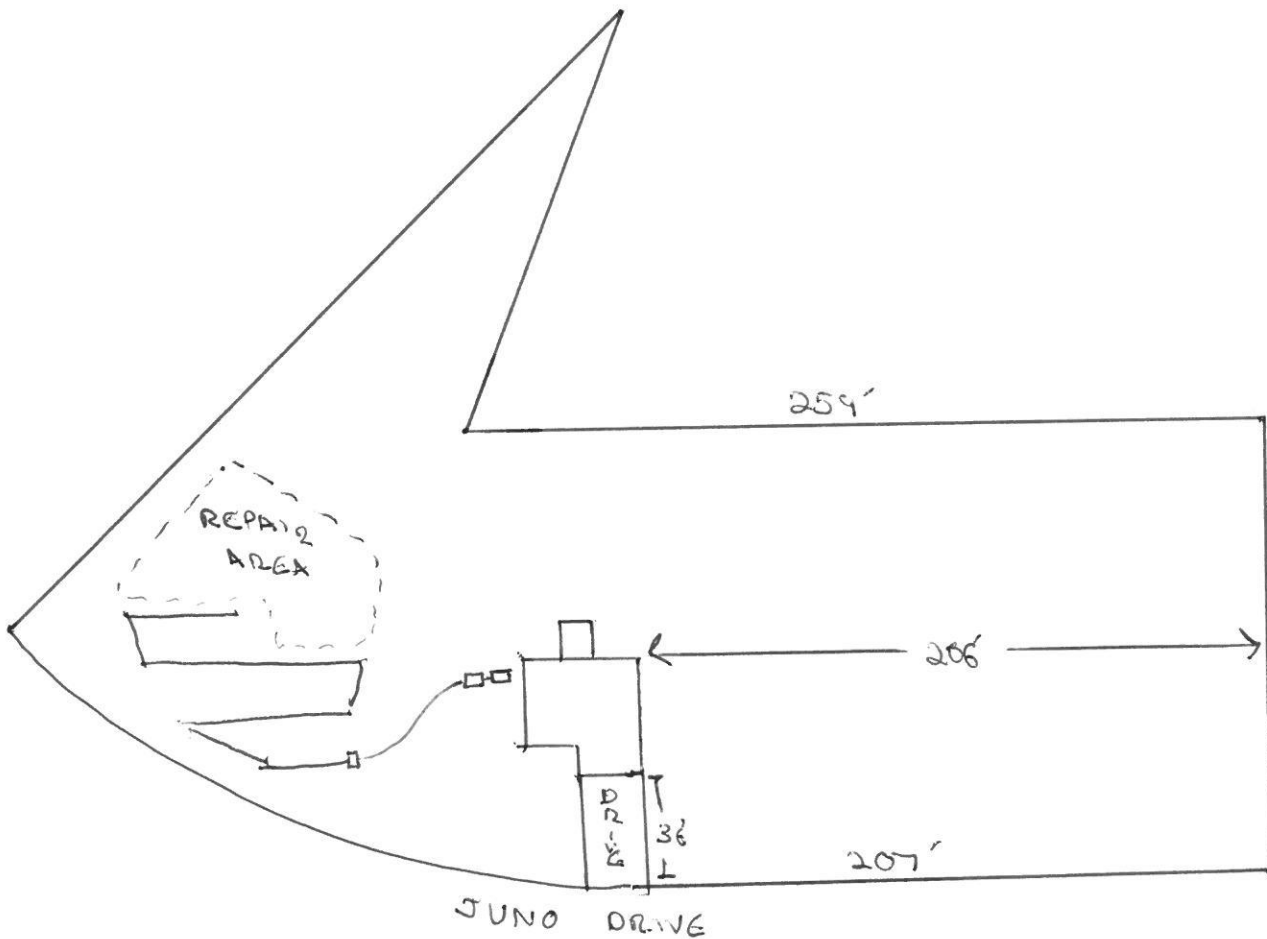

SOUTHEASTERN SOIL & ENVIRONMENTAL ASSOC., INC.

PROPOSED SUBSURFACE WASTE DISPOSAL SYSTEM DETAIL SHEET

SUBDIVISION: TINGEN POINT

LOT 152

INITIAL SYSTEM: APPROVED 25% REDUCTION

REPAIR APPROVED 25% REDUCTION

DISTRIBUTION: D-Box

DISTRIBUTION D-Box

BENCHMARK: 100.0

LOCATION PC 152/153

NO. BEDROOMS: 4

LTAR 0.4 GPD/FT<sup>2</sup>

<u>LINE</u>	<u>FLAG COLOR</u>	<u>ELEVATION</u>	<u>LENGTH</u>
1	W	108.17	75'
2	R	107.75	75'
3	Y	107.08	75'
4	W	106.08	75'
			<u>300'</u>
5	P	105.08	75'
6	Y	103.92	75'
7	W	102.84	75'
8	P	102.25	75'
			<u>300'</u>

Initial  
system

BY M. FAIGEN

DATE 08/2015

TYPICAL PROFILE (MOST LIMITING)

THERE SHALL BE NO GRADING,  
CUTTING, LOGGING OR OTHER SOIL  
DISTURBANCE IN SEPTIC AREA

0-18 CLS (VF, wgr)

18-36 SCL (F, 16N)

or 2 / PA > 36"

INSTALL AT 13"