

HTE# 13-5-31020

Harnett County Department of Public Health Improvement Permit

27431

A building permit cannot be issued with only an Improvement Permit

ISSUED TO: KRISTI SNYDER PROPERTY LOCATION: HWY 87
 SUBDIVISION: CYPRESS CREEK FARMS LOT # TR 7
 NEW REPAIR EXPANSION
 Type of Structure: 550 (32'x60')
 Proposed Wastewater System Type: 25% REDUCTION SYSTEM
 Projected Daily Flow: 360 GPD
 Number of bedrooms: 3 Number of Occupants: 6 max
 Basement Yes No
 Pump Required: Yes No May be required based on final location and elevations of facilities
 Type of Water Supply: Community Public Well Distance from well 100 feet
 Permit conditions: _____ Permit valid for: Five years
 No expiration

Authorized State Agent: [Signature] Date: 4/24/13 SEE ATTACHED SITE SKETCH
 The issuance of this permit by the Health Department in no way guarantees the issuance of other permits. The permit holder is responsible for checking with appropriate governing bodies in meeting their requirements. This site is subject to revocation if the site plan, plat, or the intended use changes. The Improvement Permit shall not be affected by a change in ownership of the site. This permit is subject to compliance with the provisions of the Laws and Rules for Sewage Treatment and Disposal and to conditions of this permit.

Construction Authorization (Required for Building Permit)

The construction and installation requirements of Rules .1950, .1952, .1954, .1955, .1956, .1957, .1958. and .1959 are incorporated by references into this permit and shall be met. Systems shall be installed in accordance with the attached system layout.

ISSUED TO: KRISTI SNYDER PROPERTY LOCATION: HWY 87
 SUBDIVISION: CYPRESS CREEK FARMS LOT # TR 7
 Facility Type: SFD (32x60) New Expansion Repair
 Basement? Yes No Basement Fixtures? Yes No
 Type of Wastewater System** 25% REDUCTION SYSTEM (Initial) Wastewater Flow: 360 GPD
 (See note below, if applicable)
25% REDUCTION SYSTEM (Repair)

Installation Requirements/Conditions
 Septic Tank Size 1000 gallons
 Pump Tank Size _____ gallons
 Number of trenches 3
 Exact length of each trench 100 feet
 Trenches shall be installed on contour at a
 Maximum Trench Depth of: 18 inches
 (Trench bottoms shall be level to +/-1/4"
 in all directions)
 Pump Requirements: _____ ft. TDH vs. _____ GPM
 _____ inches below pipe
 Aggregate Depth: _____ inches above pipe
 _____ inches total

**WATER LINES (INCLUDING IRRIGATION) MUST BE 10FT. FROM ANY PART OF SEPTIC SYSTEM OR REPAIR AREA.
NO UTILITIES ALLOWED IN INITIAL OR REPAIR DRAIN FIELD AREA.**

****If applicable: I understand the system type specified is different from the type specified on the application. I accept the specifications of this permit.**

Owner/Legal Representative Signature: _____ Date: _____
 This Construction Authorization is subject to revocation if the site plan, plat, or the intended use changes. The Construction Authorization shall not be transferred when there is a change in ownership of the site. This Construction Authorization is subject to compliance with the provisions of the Laws and Rules for Sewage Treatment and Disposal and to the conditions of this permit. SEE ATTACHED SITE SKETCH

Authorized State Agent: [Signature] Date: 4/24/13
 Construction Authorization Expiration Date: 4/24/18

HTE# 13-5-31020

Permit # 27431

Harnett County Department of Public Health Site Sketch

ISSUED TO: KATSI SNYDER PROPERTY LOCATOR: Hwy 87
SUBDIVISION CYPRESS CREEK FARMS LOT # T27

Authorized State Agent: REHS (OLIVER TOLKSDORF) Date: 4/24/13

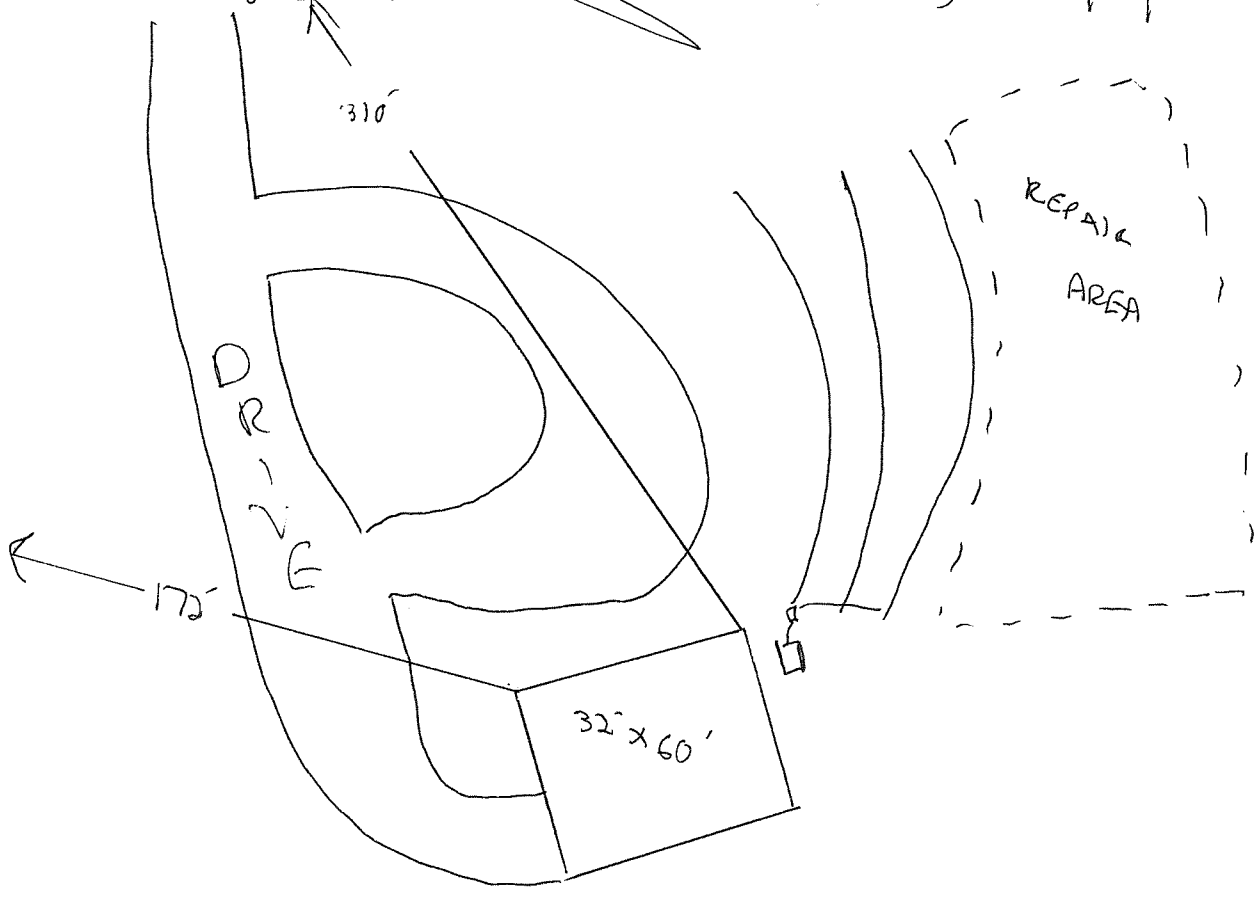

22 ACRES