ADDRESS . . : 97 STONEHURST DR
 CONTRACTOR : D.R. HORTON INC
 OWNER . . . : DR HORTON INC
 PARCEL . . . : 01-0535-14- -0100- -33-
 APPL NUMBER: 11-50026922 CP NEW RESIDENTIAL (SFD)
 DIRECTIONS : T/S: 06/16/2011 09:13 AM VBROWN ----
 STONEHURST DRIVE, STONE CROSS #103.
 210S, RIGHT ON OVERHILLS RD GO 4MI,
 RIGHT ON COBBLESTONE DR, LEFT ON
 STONEHURST DRIVE

STRUCTURE: 000 000 38X46 3BDR MONO W/ GARAGE

FLOOD ZONE : FLOOD ZONE X
 # BEDROOMS : 4.00
 SEPTIC - EXISTING? : NEW SEPTIC

PROPOSED USE : SFD
 WATER SUPPLY : COUNTY

PERMIT: CPSF 00 CP * SFD

TYP/SQ	REQUESTED COMPLETED	INSP RESULT	DESCRIPTION RESULTS/COMMENTS
P309 01	4/09/13	JH	R*PLUMB UNDER SLAB VRU #: 002363182
	4/09/13	AP	
B114 01	4/11/13	TI	R*BLDG MONO SLAB/TEMP SVC POLE VRU #: 002364933

4-11-13 APTJ

T-pole passed

COMMENTS AND NOTES

As requested by the builder, a representative of Tyndall Engineering & Design, PA (TE&D) was on-site 4-11-13 to observe the materials / conditions of the existing / exposed foundation excavations for the lot referenced above. The in-situ soils were qualitatively probed and subjected to Static Cone Penetrometer (SCP) testing. Based on the resistance values yielded, the existing / exposed excavations were noted adequate to support the anticipated loading conditions (i.e. 2000psf).

Based on our observations, analysis, and the results of our field testing, the materials / conditions of the existing foundation excavations should be structurally adequate to support the anticipated loading conditions (i.e. 2000psf).

We appreciate being able to assist you during this phase of the project. If you need further assistance or require additional information, please do not hesitate to contact us.

Sincerely,
Tyndall Engineering & Design



Eric Tyndall



TYNDALL
ENGINEERING & DESIGN, P.A.

† 919 773-1200 • † 919 773-9658
69 Shipwash Drive • Garner • North Carolina • 27529
www.tyndallengineering.com

JOB D.R. Horton
LOCATION L103 Stone Cross
CALCULATED BY ET DATE 4-11-13
SHEET NO. 1 OF 1
SCALE NTS

ADDRESS : 97 STONEHURST DR SUBDIV: STONE CROSS SECT 2 PH2A&B
 CONTRACTOR : D.R. HORTON INC PHONE : (919) 460-2969
 OWNER : DR HORTON INC PHONE : (919) 460-2933
 PARCEL : 01-0535-14- -0100- -33-
 APPL NUMBER: 11-50026922 CP NEW RESIDENTIAL (SFD)
 DIRECTIONS : T/S: 06/16/2011 09:13 AM VBROWN ----
 STONEHURST DRIVE, STONE CROSS #103.
 210S, RIGHT ON OVERHILLS RD GO 4MI,
 RIGHT ON COBBLESTONE DR, LEFT ON
 STONEHURST DRIVE

STRUCTURE: 000 000 38X46 3BDR MONO W/ GARAGE
 FLOOD ZONE : FLOOD ZONE X
 # BEDROOMS : 4.00 PROPOSED USE : SFD
 SEPTIC - EXISTING? : NEW SEPTIC WATER SUPPLY : COUNTY

PERMIT: CPSF 00 CP * SFD

TYP/SQ	REQUESTED COMPLETED	INSP RESULT	DESCRIPTION RESULTS/COMMENTS
P309 01	4/09/13	JH	R*PLUMB UNDER SLAB VRU #: 002363182
	4/09/13	AP	
B114 01	4/11/13	JH	R*BLDG MONO SLAB/TEMP SVC POLE VRU #: 002364933
	4/11/13	AP	T-POLE PASSED
H824 01	5/02/13	OT	ENVIR. OPERATIONS PERMIT TIME: 17:00 VRU #: 002377034
	5/02/13	AP	T/S: 05/03/2013 11:08 AM S STEWART T/S: 05/03/2013 11:08 AM S STEWART
R425 01	5/06/13	JH	FOUR TRADE ROUGH IN VRU #: 002376879
	5/06/13	DP	1) Nail all holes in structural nail guard over electrical pannel in garage. 2) Missing air barrier under water heater stand. 3) Plans show a 6sc @ each end of 24" lvl in garage. 4) Need structural nail guard on both sides of 3" pipe 2 water heater in garage @ top plate. 5) Missing anchor bolts throughout house per code. 6) Missing nails in I joist hangers under back side of stairs. 7) Fire caulk wire @ top plate over receptacle in spare bathroom. 8) Bolt lvl in kitchen per plans with through bolts 1/2" 9) Missing hurricane straps on back porch. 10) Fire caulk wires in top plate to right of refrig. 11) Furr out top plate @ refrig & fire caulk cracks. 12) Missing air barrier & blocking in rec room over garage per code. 13) Missing nails in roof truss hangers in rec room. 14) Missing stud to right of master bath door. STOP INSPECTION @ MASTER BATH DOOR TO MANY VIOLATIONS DO NOT INSULATE OR SIDE PAY \$50 RE FEE
A814 01	5/08/13	TI	ADDRESS CONFIRMATION TIME: 17:00 VRU #: 002378255
R425 02	5/08/13	TI	FOUR TRADE ROUGH IN TIME: 17:00 VRU #: 002378248

5-8-13 DA JV

COMMENTS AND NOTES



8600 'D' Jersey Ct
Raleigh, NC 27617

919.422.8934
866.792.5107

Firm Lic. No: P-0961

May 6, 2013

DR Horton
2000 Aerial Center PKWY STE 110
Morrisville, NC 27560
ekhedden@drhorton.com

Subject: Trusslok (Fastenmaster) LVL Beam Fastening
Location: All Projects North Carolina
Project No: EBS130449
Review Date: 5/6/2013

We are pleased to provide the structural evaluation report for the subject and location referenced above. The following comments and/or recommendations are outlined below to meet or exceed the NC Building Code.

Observations / Recommendations:

Many plans call for 1/2" thru bolt attachment to secure 4 ply LVL beams together. Contractor has requested a standard substitution schedule for trusslok fasteners to be used in lieu of the plan specified thru bolts.

Contractor may use the following trusslok fasteners and spacing as described below for side or top loaded beams. Follow manufacturers instructions for edge distance and stagger spacing requirements (see attached bulletin).

Trusslok Fastener Schedule (thru bolt replacement)

Floor Beams (3) 6.75" @ 24" o.c.
Garage Center Beams (3) 6.75" @ 12" o.c.

If you have any questions or if I can be of further assistance to you on this project, please contact me at (919) 559-8275.

Respectfully Submitted,
Elijah B. Smith, PE
JDS Consulting & Design, PLLC

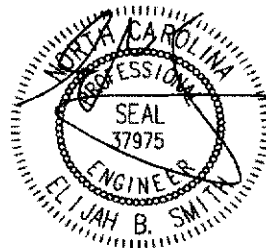

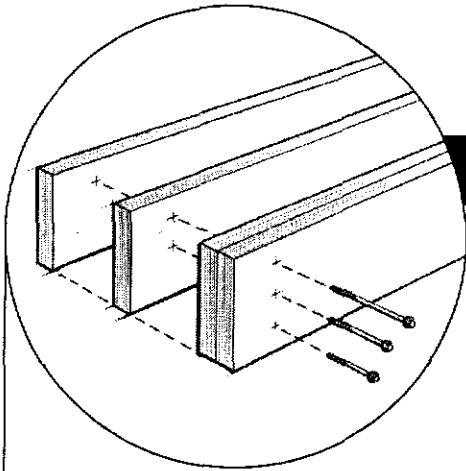

MULTIPLE MEMBER ENGINEERED WOOD BEAMS

CONNECTION DETAILS

The TrussLok Engineered Wood Fastener has been designed specifically for use in joining multiple-ply engineered wood beams (LVL, LSL & PSL). Using a standard corded or cordless 1/2" low speed/high torque drill, install screws into the side of the outermost ply. As the thread fully engages the final ply, allow the underside of the washer head to pull the plies firmly together. Do not attempt to countersink the fasteners as this may damage the beam. Refer to the information in this bulletin for proper fastener size selection and fastening pattern.



FASTENER SIZE SELECTION

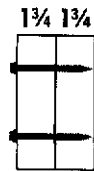

3 3/8" TRUSSLOK

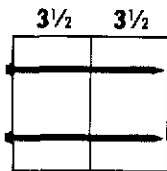

6 3/4" TRUSSLOK

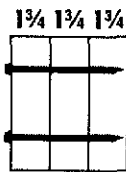

5" TRUSSLOK

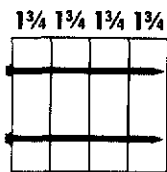

6 3/4" TRUSSLOK

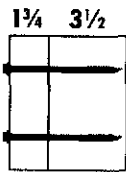

5" TRUSSLOK

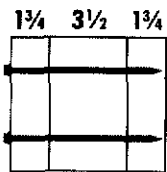

6 3/4" TRUSSLOK

FASTENER IDENTIFICATION

For easier selection and post-installation inspection, all TrussLok fasteners carry an identifying head marking.

TrussLok 3 3/8" F3.3
 TrussLok 5" F5.0
 TrussLok 6 3/4" F6.7

MINIMUM SPACING REQUIREMENTS

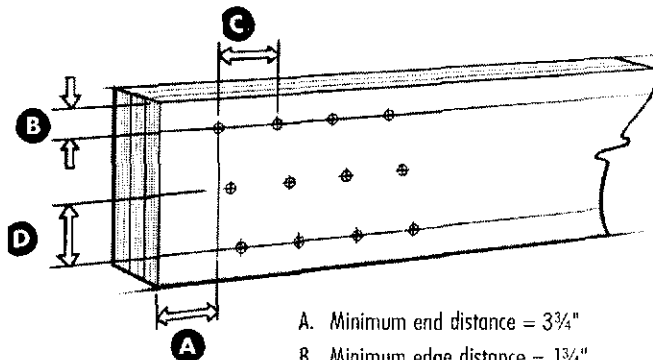

- A. Minimum end distance = 3 3/4"
- B. Minimum edge distance = 1 3/4"
- C. Minimum spacing between fasteners in a row = 3 1/2"
- D. Minimum spacing between rows of fasteners = 5/8"

GENERAL GUIDELINES

- Beams wider than 7" require special consideration by the design professional. The values on the next page do not apply.
- Excessively warped or curved LVL should never be forced into alignment by use of clamps, screws or bolts as splitting may occur, potentially decreasing the carrying capacity of the beam.
- To avoid damaging the beam, fastener heads must not be countersunk. However, if the TrussLok head needs to be brought flush, prepare the outermost ply with a countersink before installing. Using a 1/2" spade bit, drill a 1/4" deep well into the LVL in the desired fastening pattern, then install the TrussLok flush.
- Not designed for use with dimensional lumber. Use FastenMaster's TrussLok-Z fastener for multiple member dimensional wood beams.
- A qualified designer or engineer should always be consulted for critical assemblies and fastening requirements.



Effective until December 31, 2013. Updated information must be obtained after this date.

153 BOWLES ROAD, AGAWAM, MA 01001

413-789-0252

800-518-3569

WWW.FASTENMASTER.COM

FASTENING PATTERN

Top Loaded Beams

Where all floor joists sit on the beam, fasteners should be spaced two every 24" on center in a staggered pattern as shown.

For beam depths of 18" or more, this pattern should be increased to three fasteners every 24" on center.

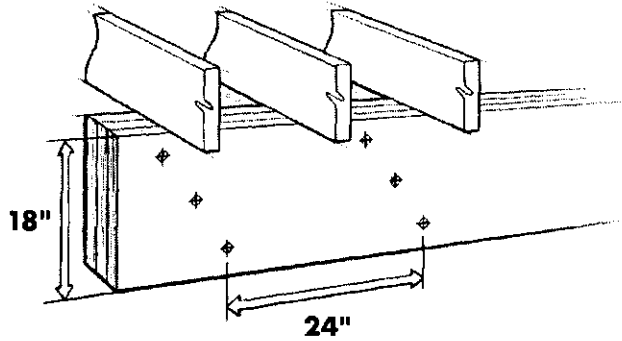
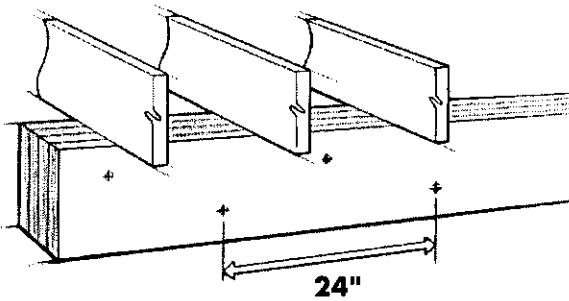

Side Loaded Beams

Where floor joists are joined to the side of the beam (typically using a joist hanger), this load chart must be used to establish the proper pattern based on the design load as determined by the engineer and noted on the plans.

Assembly Type

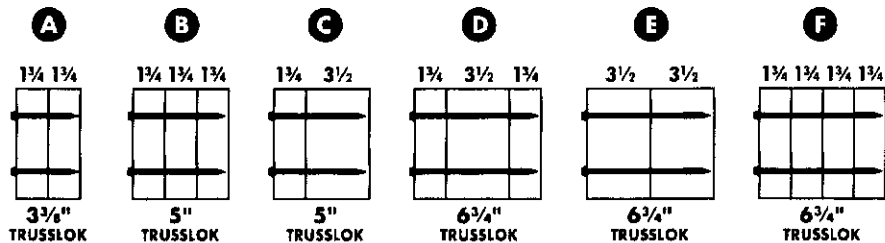

- Allowable loads are derived from tested fastener values as reported in ESR #1078 (see www.iccc-es.org).
- A specific gravity of 0.5 was used for all engineered wood (EW) calculations.
- The uniform loads in this table relate only to the capacity of the fastener to transfer shear loads between plies. The capacity of the EW beam may be less and should be checked against the manufacturer's literature.
- Values listed reflect 100% stress level ($C_D=1.0$). The designer may apply adjustment factors to increase or decrease these loads per 2005 NDS based on conditions for each assembly.
- To minimize rotation, 7" wide beams shall be side loaded only when loads are applied to both sides of the beam with the lesser loaded side bearing at least 25% of the overall design load.
- 24" on-center connection values may be doubled for 12" on-center spacing.

TRUSSLOK	NO of SCREWS	SPACING BETWEEN ROWS	ALLOWABLE SIDE LOADS BY ASSEMBLY TYPE					
			A	B	C	D	E	F
3 3/8"	2	24"	580					
	2	19.2	725					
	2	16	870					
	3	24"	870					
	3	19.2	1090					
5"	3	16	1305					
	2	24"		450	450			
	2	19.2		560	560			
	2	16		670	670			
	3	24"		670	670			
	3	19.2		840	840			
6 3/4"	3	16		1010	1010			
	2	24"				415	620	415
	2	19.2				515	775	515
	2	16				620	930	620
	3	24"				620	930	620
	3	19.2				775	1165	775
	3	16				930	1395	930