

Harnett County

ADDRESS . . : 136 REGAL CREST DR
 CONTRACTOR : MCLAURIN DENNIS M
 OWNER . . . : J BLANCHARD FARMS LLC
 PARCEL . . . : 05-0633- - -0013- -10-
 APPL NUMBER: 10-50024079 CP NEW RESIDENTIAL (SFD)
 DIRECTIONS : T/S: 03/30/2010 10:04 AM VBROWN ----
 136 REGAL CREST DRIVE FUQUAY VARINIA
 27526, REGAL CREST SUB DIV #11. 401N,
 LEFT ON CHRISTIAN LIGHT RD, LEFT ON
 RIVER RD, RIGHT ON REGAL CREST, LOT 11
 ON RIGHT.

SUBDIV: REGAL CREST 13LOTS
 PHONE : (919) 552-9540
 PHONE :

STRUCTURE: 000 000 60X70 4BDR 3.5BATH SFD WITH GAR CRAWL

FLOOD ZONE : FLOOD ZONE X
 # BEDROOMS : 4.00
 SEPTIC - EXISTING? : NEW SEPTIC
 PROPOSED USE : SFD
 WATER SUPPLY : COUNTY

PERMIT: CPSF 00 CP * SFD

TYP/SQ	REQUESTED COMPLETED	INSP RESULT	DESCRIPTION RESULTS/COMMENTS
--------	------------------------	----------------	---------------------------------

B101 01	6/21/10 <i>6-21-10</i>	TI <i>APB</i>	R*BLDG FOOTING / TEMP SVC POLE VRU #: 001943366
---------	---------------------------	------------------	---

COMMENTS AND NOTES

ADDRESS . . : 136 REGAL CREST DR
CONTRACTOR : MCLAURIN DENNIS M
OWNER . . . : J BLANCHARD FARMS LLC
PARCEL . . . : 05-0633- - -0013- -10-
APPL NUMBER: 10-50024079 CP NEW RESIDENTIAL (SFD)
DIRECTIONS : T/S: 03/30/2010 10:04 AM VBROWN -----
136 REGAL CREST DRIVE FUQUAY VARINIA
27526, REGAL CREST SUB DIV #11. 401N,
LEFT ON CHRISTIAN LIGHT RD, LEFT ON
RIVER RD, RIGHT ON REGAL CREST, LOT 11
ON RIGHT.
T/S: 06/28/2010 12:04 PM VBROWN -----
PREMIS 39589509

SUBDIV: REGAL CREST 13LOTS
PHONE : (919) 552-9540
PHONE :

STRUCTURE: 000 000 60X70 4BDR 3.5BATH SFD WITH GAR CRAWL

FLOOD ZONE : FLOOD ZONE X
BEDROOMS : 4.00
SEPTIC - EXISTING? : NEW SEPTIC
PROPOSED USE : SFD
WATER SUPPLY : COUNTY

PERMIT: CPSF 00 CP * SFD

TYP/SQ	REQUESTED COMPLETED	INSP RESULT	DESCRIPTION RESULTS/COMMENTS
B101 01	6/21/10	BS	R*BLDG FOOTING / TEMP SVC POLE VRU #: 001943366
	6/21/10	AP	T/S: June 21, 2010 09:40 AM BSUTTON -----
B103 01	6/29/10 <u>6-29-10</u>	TI <u>ABS</u>	R*BLDG FOUND & TEMP SVC POLE TIME: 17:00 VRU #: 001947332 T/S: 06/28/2010 12:03 PM VBROWN ----- PREMIS NUMBER 39589509

COMMENTS AND NOTES

ADDRESS . . : 136 REGAL CREST DR
 CONTRACTOR : MCLAURIN DENNIS M
 OWNER . . . : J BLANCHARD FARMS LLC
 PARCEL . . . : 05-0633- - -0013- -10-
 APPL NUMBER: 10-50024079 CP NEW RESIDENTIAL (SFD)
 DIRECTIONS : T/S: 03/30/2010 10:04 AM VBROWN ----
 136 REGAL CREST DRIVE FUQUAY VARINIA
 27526, REGAL CREST SUB DIV #11. 40LN,
 LEFT ON CHRISTIAN LIGHT RD, LEFT ON
 RIVER RD, RIGHT ON REGAL CREST, LOT 11
 ON RIGHT.
 T/S: 06/28/2010 12:04 PM VBROWN ----
 PREMIS 39589509

STRUCTURE: 000 000 60X70 4BDR 3.5BATH SFD WITH GAR CRAWL

FLOOD ZONE : FLOOD ZONE X
 # BEDROOMS : 4.00
 SEPTIC - EXISTING? : NEW SEPTIC

PROPOSED USE : SFD
 WATER SUPPLY : COUNTY

PERMIT: CPSF 00 CP * SFD

TYP/SQ	REQUESTED COMPLETED	INSP RESULT	DESCRIPTION RESULTS/COMMENTS
B101 01	6/21/10	BS	R*BLDG FOOTING / TEMP SVC POLE VRU #: 001943366
	6/21/10	AP	T/S: June 21, 2010 09:40 AM BSUTTON -----
B103 01	6/29/10	BS	R*BLDG FOUND & TEMP SVC POLE TIME: 17:00 VRU #: 001947332
	6/29/10	AE	T/S: 06/28/2010 12:03 PM VBROWN ----- PREMIS NUMBER 39589509 apply damproofing from footing up to final grade height, leave exterior of foundation open. Will check at open floor inspection
A814 01	7/06/10	TI	ADDRESS CONFIRMATION TIME: 17:00 VRU #: 001949585
			T/S: 07/02/2010 11:13 AM RDCONTE -----
B105 01	7/06/10	TI	R*OPEN FLOOR TIME: 17:00 VRU #: 001949577
	<u>7-6-10</u>	<u>APBS</u>	T/S: 07/02/2010 11:13 AM RDCONTE -----

----- COMMENTS AND NOTES -----

Harnett County

INSPECTOR: IVR

DATE

8/17/10

ADDRESS : 136 REGAL CREST DR
 CONTRACTOR : MCLAURIN DENNIS M
 OWNER : J BLANCHARD FARMS LLC
 PARCEL : 05-0633- - -0013- -10-
 APPL NUMBER: 10-50024079 CP NEW RESIDENTIAL (SFD)
 DIRECTIONS : T/S: 03/30/2010 10:04 AM VBROWN ----
 136 REGAL CREST DRIVE FUQUAY VARINIA
 27526, REGAL CREST SUB DIV #11. 401N,
 LEFT ON CHRISTIAN LIGHT RD, LEFT ON
 RIVER RD, RIGHT ON REGAL CREST, LOT 11
 ON RIGHT.
 T/S: 06/28/2010 12:04 PM VBROWN ----
 PREMIS 39589509

SUBDIV: REGAL CREST 13LOTS
 PHONE : (919) 552-9540
 PHONE :

STRUCTURE: 000 000 60X70 4BDR 3.5BATH SFD WITH GAR CRAWL

FLOOD ZONE : FLOOD ZONE X
 # BEDROOMS : 4.00 PROPOSED USE : SFD
 SEPTIC - EXISTING? : NEW SEPTIC WATER SUPPLY : COUNTY

PERMIT: CPSF 00 CP * SFD

TYP/SQ	REQUESTED COMPLETED	INSP RESULT	DESCRIPTION RESULTS/COMMENTS
B101 01	6/21/10	BS	R*BLDG FOOTING / TEMP SVC POLE VRU #: 001943366
	6/21/10	AP	T/S: June 21, 2010 09:40 AM BSUTTON -----
B103 01	6/29/10	BS	R*BLDG FOUND & TEMP SVC POLE TIME: 17:00 VRU #: 001947332
	6/29/10	AE	T/S: 06/28/2010 12:03 PM VBROWN ----- PREMIS NUMBER 39589509 apply damproofing from footing up to final grade height, leave exterior of foundation open. Will check at open floor inspection
A814 01	7/06/10	TW	ADDRESS CONFIRMATION TIME: 17:00 VRU #: 001949585
	7/06/10	AP	T/S: 07/02/2010 11:13 AM RDCONTE ----- 136 REGAL CREST DR LOT 11 ----- FUQUAY VARINA 27526
B105 01	7/06/10	BS	R*OPEN FLOOR TIME: 17:00 VRU #: 001949577
	7/06/10	AP	T/S: 07/02/2010 11:13 AM RDCONTE ----- T/S: July 06, 2010 01:42 PM BSUTTON -----
P307 01	8/17/10	TI	R*PLUMB WATER CONNECTION VRU #: 001970334
	<u>8/17/10</u>	<u>APR</u>	

COMMENTS AND NOTES

PREPARED 8/26/10, 14:00:49
Harnett County

INSPECTION TICKET
INSPECTOR: IVR

 ADDRESS . . : 136 REGAL CREST DR
 CONTRACTOR : MCLAURIN DENNIS M
 OWNER . . . : J BLANCHARD FARMS LLC
 PARCEL . . . : 05-0633- - -0013- -10-
 APPL NUMBER: 10-50024079 CP NEW RESIDENTIAL (SFD)
 DIRECTIONS : T/S: 03/30/2010 10:04 AM VBROWN ----
 136 REGAL CREST DRIVE FUQUAY VARINIA
 27526, REGAL CREST SUB DIV #11. 401N,
 LEFT ON CHRISTIAN LIGHT RD, LEFT ON
 RIVER RD, RIGHT ON REGAL CREST, LOT 11
 ON RIGHT.
 T/S: 06/28/2010 12:04 PM VBROWN ----
 PREMIS 39589509
 SUBDIV: REGAL CREST 13LOTS
 PHONE : (919) 552-9540
 PHONE :

STRUCTURE: 000 000 60X70 4BDR 3.5BATH SFD WITH GAR CRAWL
 FLOOD ZONE : FLOOD ZONE X
 # BEDROOMS : 4.00
 SEPTIC - EXISTING? : NEW SEPTIC
 PROPOSED USE : SFD
 WATER SUPPLY : COUNTY

PERMIT: CPSF 00 CP * SFD

TYP/SQ	REQUESTED COMPLETED	INSP RESULT	DESCRIPTION RESULTS/COMMENTS
B101 01	6/21/10	BS	R*BLDG FOOTING / TEMP SVC POLE VRU #: 001943366
	6/21/10	AP	T/S: June 21, 2010 09:40 AM BSUTTON -----
B103 01	6/29/10	BS	R*BLDG FOUND & TEMP SVC POLE TIME: 17:00 VRU #: 001947332
	6/29/10	AE	T/S: 06/28/2010 12:03 PM VBROWN ----- PREMIS NUMBER 39589509 apply damproofing from footing up to final grade height, leave exterior of foundation open. Will check at open floor inspection
A814 01	7/06/10	TW	ADDRESS CONFIRMATION TIME: 17:00 VRU #: 001949585
	7/06/10	AP	T/S: 07/02/2010 11:13 AM RDCONTE ----- 136 REGAL CREST DR LOT 11 ----- FUQUAY VARINA 27526
B105 01	7/06/10	BS	R*OPEN FLOOR TIME: 17:00 VRU #: 001949577
	7/06/10	AP	T/S: 07/02/2010 11:13 AM RDCONTE ----- T/S: July 06, 2010 01:42 PM BSUTTON -----
P307 01	8/17/10	BS	R*PLUMB WATER CONNECTION VRU #: 001970334
	8/17/10	AP	T/S: August 17, 2010 02:30 PM BSUTTON -----
R427 01	8/27/10	TI	FOUR TRADE ROUGH IN >2500 VRU #: 001975571
	<u>8-27-10</u>	<u>APB</u>	

 COMMENTS AND NOTES -----

ADDRESS : 136 REGAL CREST DR
 CONTRACTOR : MCLAURIN DENNIS M
 OWNER : J BLANCHARD FARMS LLC
 PARCEL : 05-0633- - -0013- -10-
 APPL NUMBER: 10-50024079 CP NEW RESIDENTIAL (SFD)
 DIRECTIONS : T/S: 03/30/2010 10:04 AM VBROWN ----
 136 REGAL CREST DRIVE FUQUAY VARINIA
 27526, REGAL CREST SUB DIV #11. 401N,
 LEFT ON CHRISTIAN LIGHT RD, LEFT ON
 RIVER RD, RIGHT ON REGAL CREST, LOT 11
 ON RIGHT.
 T/S: 06/28/2010 12:04 PM VBROWN ----
 PREMIS 39589509

STRUCTURE: 000 000 60X70 4BDR 3.5BATH SFD WITH GAR CRAWL

FLOOD ZONE : FLOOD ZONE X
 # BEDROOMS : 4.00
 SEPTIC - EXISTING? : NEW SEPTIC
 PROPOSED USE : SFD
 WATER SUPPLY : COUNTY

PERMIT: CPSF 00 CP * SFD

TYP/SQ	REQUESTED COMPLETED	INSP RESULT	DESCRIPTION RESULTS/COMMENTS
B101 01	6/21/10	BS	R*BLDG FOOTING / TEMP SVC POLE VRU #: 001943366
	6/21/10	AP	T/S: June 21, 2010 09:40 AM BSUTTON -----
B103 01	6/29/10	BS	R*BLDG FOUND & TEMP SVC POLE TIME: 17:00 VRU #: 001947332
	6/29/10	AE	T/S: 06/28/2010 12:03 PM VBROWN ----- PREMIS NUMBER 39589509 apply damproofing from footing up to final grade height, leave exterior of foundation open. Will check at open floor inspection
A814 01	7/06/10	TW	ADDRESS CONFIRMATION TIME: 17:00 VRU #: 001949585
	7/06/10	AP	T/S: 07/02/2010 11:13 AM RDCONTE ----- 136 REGAL CREST DR LOT 11 ----- FUQUAY VARINA 27526
B105 01	7/06/10	BS	R*OPEN FLOOR TIME: 17:00 VRU #: 001949577
	7/06/10	AP	T/S: 07/02/2010 11:13 AM RDCONTE ----- T/S: July 06, 2010 01:42 PM BSUTTON -----
P307 01	8/17/10	BS	R*PLUMB WATER CONNECTION VRU #: 001970334
	8/17/10	AP	T/S: August 17, 2010 02:30 PM BSUTTON -----
R427 01	8/27/10	BS	FOUR TRADE ROUGH IN >2500 VRU #: 001975571
	8/27/10	AP	Water heaters must be within 20 feet of foundation access door. Will check at final.
I129 01	9/02/10	TI	R*INSULATION INSPECTION VRU #: 001977445

9-2-10 APB

COMMENTS AND NOTES

G. Install Metal Roof Flashing

- See minimum vent heights for various pitched roofs (Figure 10.14) to determine the length of pipe to extend through the roof.
- Slide the roof flashing over the pipe sections extending through the roof as shown in Figure 10.15.

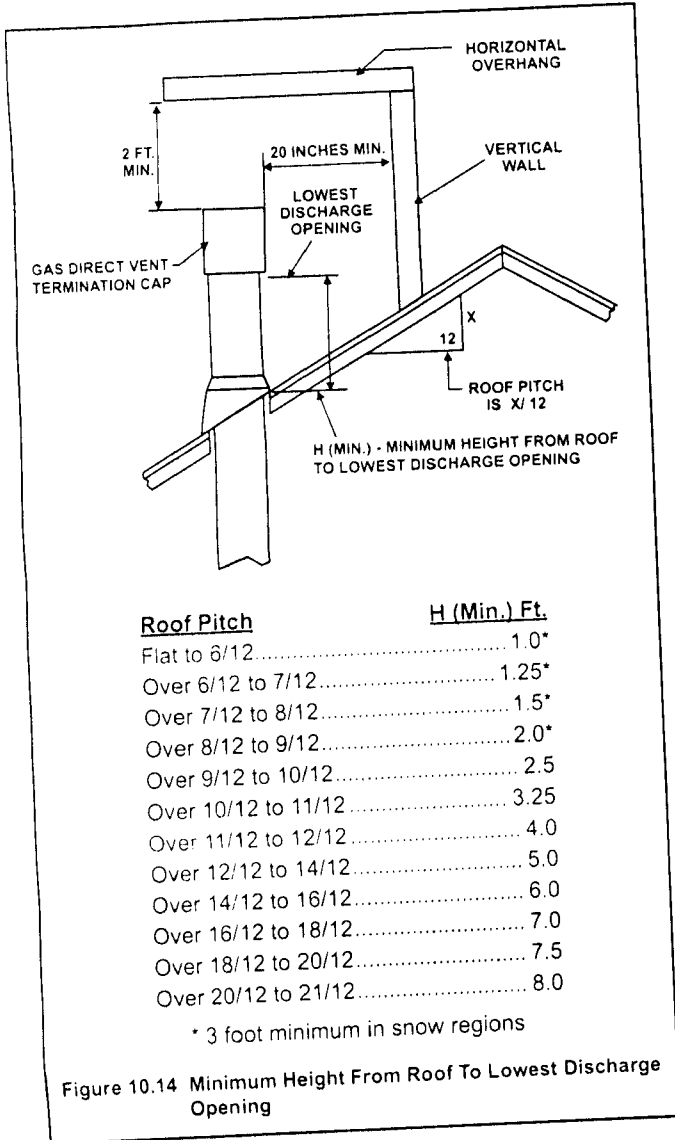

NOTICE: Failure to properly caulk the roof flashing could cause water entry.

- Caulk the gap between the roof flashing and the outside diameter of the pipe.
- Caulk the perimeter of the flashing where it contacts the roof surface. See Figure 10.15.

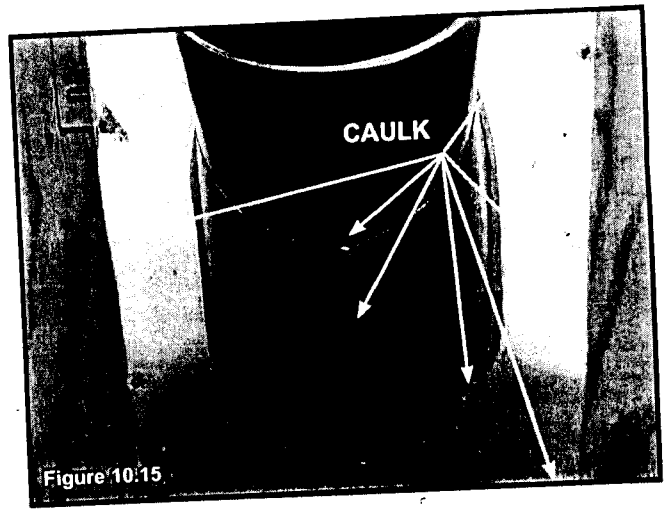

H. Assemble and Install Storm Collar

CAUTION! Risk of Cuts, Abrasions or Flying Debris. Wear protective gloves and safety glasses during installation. Sheet metal edges are sharp.

- Connect both halves of the storm collar with two screws (see Figure 10.16).
- Wrap the storm collar around the exposed pipe section closest to the roof and align brackets. Insert a bolt (provided) through the brackets and tighten the nut to complete the storm collar assembly. Make sure the collar is tight against the pipe section.
- Slide the assembled storm collar down the pipe section until it rests on the roof flashing (see Figure 10.17).
- Caulk around the top of the storm collar (see Figure 10.18).

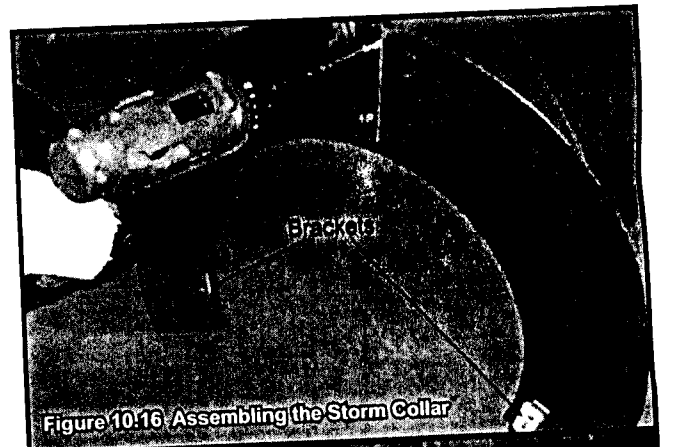

Figure 10.17 Assembling the Storm Collar Around the Pipe

ADDRESS : 136 REGAL CREST DR
 CONTRACTOR : MCLAURIN DENNIS M
 OWNER : J BLANCHARD FARMS LLC
 PARCEL : 05-0633- - -0013- -10-
 APPL NUMBER: 10-50024079 CP NEW RESIDENTIAL (SFD)
 DIRECTIONS : T/S: 03/30/2010 10:04 AM VBROWN ----
 136 REGAL CREST DRIVE FUQUAY VARINIA
 27526, REGAL CREST SUB DIV #11. 401N,
 LEFT ON CHRISTIAN LIGHT RD, LEFT ON
 RIVER RD, RIGHT ON REGAL CREST, LOT 11
 ON RIGHT.
 T/S: 06/28/2010 12:04 PM VBROWN ----
 PREMIS 39589509

SUBDIV: REGAL CREST 13LOTS
 PHONE : (919) 552-9540
 PHONE :

STRUCTURE: 000 000 60X70 4BDR 3.5BATH SFD WITH GAR CRAWL

FLOOD ZONE : FLOOD ZONE X
 # BEDROOMS : 4.00
 SEPTIC - EXISTING? : NEW SEPTIC
 PROPOSED USE : SFD
 WATER SUPPLY : COUNTY

PERMIT: CPSF 00 CP * SFD

TYP/SQ	REQUESTED COMPLETED	INSP RESULT	DESCRIPTION RESULTS/COMMENTS
B101 01	6/21/10	BS	R*BLDG FOOTING / TEMP SVC POLE VRU #: 001943366 T/S: June 21, 2010 09:40 AM BSUTTON
B103 01	6/29/10	BS	R*BLDG FOUND & TEMP SVC POLE TIME: 17:00 VRU #: 001947332 T/S: 06/28/2010 12:03 PM VBROWN PREMIS NUMBER 39589509 apply damproofing from footing up to final grade height, leave exterior of foundation open. Will check at open floor inspection
A814 01	7/06/10	TW	ADDRESS CONFIRMATION TIME: 17:00 VRU #: 001949585 T/S: 07/02/2010 11:13 AM RDCONTE
	7/06/10	AP	✓ 136 REGAL CREST DR LOT 11 FUQUAY VARINA 27526 T/S: 07/06/2010 09:04 AM TWARD
B105 01	7/06/10	BS	R*OPEN FLOOR TIME: 17:00 VRU #: 001949577 T/S: 07/02/2010 11:13 AM RDCONTE
	7/06/10	AP	T/S: July 06, 2010 01:42 PM BSUTTON
P307 01	8/17/10	BS	R*PLUMB WATER CONNECTION VRU #: 001970334 T/S: August 17, 2010 02:30 PM BSUTTON
R427 01	8/27/10	BS	FOUR TRADE ROUGH IN >2500 VRU #: 001975571 Water heaters must be within 20 feet of foundation access door. Will check at final.
	8/27/10	AP	
I129 01	9/02/10	BS	R*INSULATION INSPECTION VRU #: 001977445 T/S: September 02, 2010 09:45 AM BSUTTON
	9/02/10	AP	
H824 01	10/08/10	JM	✓ ENVIR. OPERATIONS PERMIT TIME: 17:00 VRU #: 001992387 T/S: 10/11/2010 08:40 AM SZIMMER
	10/08/10	AP	T/S: 10/11/2010 08:41 AM SZIMMER
R431 01	12/17/10	TI	FOUR TRADE FINAL >2500 VRU #: 002020155

12-17-10

COMMENTS AND NOTES

ADDRESS : 136 REGAL CREST DR
 CONTRACTOR : MCLAURIN DENNIS M
 OWNER : J BLANCHARD FARMS LLC
 PARCEL : 05-0633- - -0013- -10-
 APPL NUMBER: 10-50024079 CP NEW RESIDENTIAL (SFD)
 DIRECTIONS : T/S: 03/30/2010 10:04 AM VBROWN ----
 136 REGAL CREST DRIVE FUQUAY VARINIA
 27526, REGAL CREST SUB DIV #11. 401N,
 LEFT ON CHRISTIAN LIGHT RD, LEFT ON
 RIVER RD, RIGHT ON REGAL CREST, LOT 11
 ON RIGHT.
 T/S: 06/28/2010 12:04 PM VBROWN ----
 PREMIS 39589509

SUBDIV: REGAL CREST 13LOTS
 PHONE : (919) 552-9540
 PHONE :

STRUCTURE: 000 000 60X70 4BDR 3.5BATH SFD WITH GAR CRAWL

FLOOD ZONE : FLOOD ZONE X
 # BEDROOMS : 4.00
 SEPTIC - EXISTING? : NEW SEPTIC
 PROPOSED USE : SFD
 WATER SUPPLY : COUNTY

PERMIT: CPSF 00 CP * SFD

TYP/SQ	REQUESTED COMPLETED	INSP RESULT	DESCRIPTION RESULTS/COMMENTS
B101 01	6/21/10	BS	R*BLDG FOOTING / TEMP SVC POLE VRU #: 001943366
	6/21/10	AP	T/S: June 21, 2010 09:40 AM BSUTTON
B103 01	6/29/10	BS	R*BLDG FOUND & TEMP SVC POLE TIME: 17:00 VRU #: 001947332
	6/29/10	AE	T/S: 06/28/2010 12:03 PM VBROWN PREMIS NUMBER 39589509 apply damproofing from footing up to final grade height, leave exterior of foundation open. Will check at open floor inspection
A814 01	7/06/10	TW	ADDRESS CONFIRMATION TIME: 17:00 VRU #: 001949585
	7/06/10	AP	T/S: 07/02/2010 11:13 AM RDCONTE ✓ 136 REGAL CREST DR LOT 11 FUQUAY VARINA 27526
B105 01	7/06/10	BS	R*OPEN FLOOR TIME: 17:00 VRU #: 001949577
	7/06/10	AP	T/S: 07/02/2010 11:13 AM RDCONTE T/S: July 06, 2010 01:42 PM BSUTTON
P307 01	8/17/10	BS	R*PLUMB WATER CONNECTION VRU #: 001970334
	8/17/10	AP	T/S: August 17, 2010 02:30 PM BSUTTON
R427 01	8/27/10	BS	FOUR TRADE ROUGH IN >2500 VRU #: 001975571
	8/27/10	AP	Water heaters must be within 20 feet of foundation access door. Will check at final.
I129 01	9/02/10	BS	R*INSULATION INSPECTION VRU #: 001977445
	9/02/10	AP	T/S: September 02, 2010 09:45 AM BSUTTON
H824 01	10/08/10	JM	✓ ENVIR. OPERATIONS PERMIT TIME: 17:00 VRU #: 001992387
	10/08/10	AP	T/S: 10/11/2010 08:40 AM SZIMMER T/S: 10/11/2010 08:41 AM SZIMMER
R431 01	12/17/10	BS	FOUR TRADE FINAL >2500 VRU #: 002020155
	12/17/10	DA	1. Close off cantilever at rear deck. 2. Air handlers not labeled with heat kit info. 3. Finish plastic under house. NO FEE
R431 02	12/21/10	TI	FOUR TRADE FINAL >2500 VRU #: 002021243
	12/21/10	APBS	

COMMENTS AND NOTES

County of Harnett
Building Inspections Department
Planning Services

Certificate of Compliance: ___ Occupancy: X

Certificate issued pursuant to the requirements of North Carolina General Statute 153A-363 and Harnett County Zoning Ordinances. This certifies at the time of issuance, this structure was in compliance with the various ordinances of the County of Harnett and the North Carolina State Building Codes. For the following:

Use Classification: SFD

Permit Numbers

Name: Barbara Wilson

Building: 10-50024079

Address: 136 Regal Crest Drive

Electrical: 10-50024079

Fuquay Varina NC 27526

Insulation: 10-50024079

Plumbing: 10-50024079

Mechanical: 10-50024079

MFG Home: NANANANA

Date: 12-21-2010

Building Official: BSutton



Central Permitting & Community Development

December 23, 2010

Dennis McLaurin
7567 Christian Light Rd
Fuquay-Varina NC 27526

RE: 136 Regal Crest Drive
Property Lien and/or Outstanding Fees

Dear Mr. McLaurin,

I am writing this letter to notify you that there are NEITHER outstanding fees NOR property liens associated with the permits or certificate of occupancy issued by the County of Harnett, Central Permitting or Inspections Department for application #'s 10-50024079 (SFD) or 10-24540 (Detached Garage).

If you have any questions or comments, please contact me at 910.814.6430 or bblevins@harnett.org.

Sincerely,

A handwritten signature in black ink, appearing to read 'Barry A. Blevins', written over a horizontal line.

Barry A. Blevins
Central Permitting & Community Development