

ADDRESS : 638 VALLEY OAK DR
CONTRACTOR : H & H CONSTRUCTORS INC
OWNER : H&H CONSTRUCTORS, INC
PARCEL : 01-0536-05- -0028- -54-
APPL NUMBER: 09-50021671 CP NEW RESIDENTIAL (SFD)
DIRECTIONS : FOREST OAKS PH3 #167
TAKE HWY 27 TO NURSERY ROAD, TURN LEFT.
TURN LEFT ON LEMUEL BLACK ROAD. TURN
LEFT ON VALLEY OAK INTO FOREST OAKS.
POWER CO: WAITING ON CUSTOMER
T/S: 03/05/2009 09:44 AM RDCONTE ---

SUBDIV: FOREST OAKS PH 3 99LOTS
PHONE : (910) 486-4864
PHONE : (910) 486-4864

STRUCTURE: 000 000 73.7X54 SLAB 4BED 2BATH W/GAR & DECK

FLOOD ZONE : FLOOD ZONE X

BEDROOMS : 4.00

SEPTIC - EXISTING? : NEW TANK

PROPOSED USE : SFD

WATER SUPPLY : COUNTY

PERMIT: CPSF 00 CP * SFD

TYP/SQ	REQUESTED COMPLETED	INSP RESULT	DESCRIPTION RESULTS/COMMENTS	VRU #:
B101 01	5/27/09 <u>5/27/09</u>	TI <u>APDT</u>	R*BLDG FOOTING / TEMP SVC POLE	001772367

COMMENTS AND NOTES

ADDRESS . . : 638 VALLEY OAK DR
 CONTRACTOR : H & H CONSTRUCTORS INC
 OWNER . . . : H&H CONSTRUCTORS, INC
 PARCEL . . . : 01-0536-05- -0028- -54-
 APPL NUMBER: 09-50021671 CP NEW RESIDENTIAL (SFD)
 DIRECTIONS : FOREST OAKS PH3 #167
 TAKE HWY 27 TO NURSERY ROAD, TURN LEFT.
 TURN LEFT ON LEMUEL BLACK ROAD. TURN
 LEFT ON VALLEY OAK INTO FOREST OAKS.
 POWER CO: WAITING ON CUSTOMER
 T/S: 03/05/2009 09:44 AM RDCONTE ---

STRUCTURE: 000 000 73.7X54 SLAB 4BED 2BATH W/GAR & DECK

FLOOD ZONE : FLOOD ZONE X
 # BEDROOMS : 4.00
 SEPTIC - EXISTING? : NEW TANK

PROPOSED USE : SFD
 WATER SUPPLY : COUNTY

PERMIT: CPSF 00 CP * SFD

TYP/SQ	REQUESTED COMPLETED	INSP RESULT	DESCRIPTION RESULTS/COMMENTS
B101 01	5/27/09	DT	R*BLDG FOOTING / TEMP SVC POLE VRU #: 001772367
	5/27/09	AP	
A814 01	5/29/09	TI	ADDRESS CONFIRMATION VRU #: 001774249
B103 01	5/29/09	TI	R*BLDG FOUND & TEMP SVC POLE VRU #: 001774256
	<u>5/29/09</u>	<u>AP DT</u>	

COMMENTS AND NOTES

ADDRESS : 638 VALLEY OAK DR
CONTRACTOR : H & H CONSTRUCTORS INC
OWNER : H&H CONSTRUCTORS, INC
PARCEL : 01-0536-05- -0028- -54-
APPL NUMBER: 09-50021671 CP NEW RESIDENTIAL (SFD)
DIRECTIONS : FOREST OAKS PH3 #167
TAKE HWY 27 TO NURSERY ROAD, TURN LEFT.
TURN LEFT ON LEMUEL BLACK ROAD. TURN
LEFT ON VALLEY OAK INTO FOREST OAKS.
POWER CO: WAITING ON CUSTOMER
T/S: 03/05/2009 09:44 AM RDCONTE ---

SUBDIV: FOREST OAKS PH 3 99LOTS
PHONE : (910) 486-4864
PHONE : (910) 486-4864

STRUCTURE: 000 000 73.7X54 SLAB 4BED 2BATH W/GAR & DECK

FLOOD ZONE : FLOOD ZONE X

BEDROOMS : 4.00

PROPOSED USE : SFD

SEPTIC - EXISTING? : NEW TANK

WATER SUPPLY : COUNTY

PERMIT: CPSF 00 CP * SFD

TYP/SQ	REQUESTED COMPLETED	INSP RESULT	DESCRIPTION RESULTS/COMMENTS
B101 01	5/27/09	DT	R*BLDG FOOTING / TEMP SVC POLE VRU #: 001772367
	5/27/09	AP	
A814 01	5/29/09	TI	ADDRESS CONFIRMATION VRU #: 001774249
B103 01	5/29/09	DT	R*BLDG FOUND & TEMP SVC POLE VRU #: 001774256
	5/29/09	AP	
P309 01	6/03/09	TI	R*PLUMB UNDER SLAB VRU #: 001776129

6.3-9 AP-MR

COMMENTS AND NOTES

ADDRESS : 638 VALLEY OAK DR SUBDIV: FOREST OAKS PH 3 99LOTS
 CONTRACTOR : H & H CONSTRUCTORS INC PHONE : (910) 486-4864
 OWNER : H&H CONSTRUCTORS, INC PHONE : (910) 486-4864
 PARCEL : 01-0536-05- -0028- -54-
 APPL NUMBER: 09-50021671 CP NEW RESIDENTIAL (SFD)
 DIRECTIONS : FOREST OAKS PH3 #167
 TAKE HWY 27 TO NURSERY ROAD, TURN LEFT.
 TURN LEFT ON LEMUEL BLACK ROAD. TURN
 LEFT ON VALLEY OAK INTO FOREST OAKS.
 POWER CO: WAITING ON CUSTOMER
 T/S: 03/05/2009 09:44 AM RDCONTE ---

STRUCTURE: 000 000 73.7X54 SLAB 4BED 2BATH W/GAR & DECK
 FLOOD ZONE : FLOOD ZONE X
 # BEDROOMS : 4.00 PROPOSED USE : SFD
 SEPTIC - EXISTING? : NEW TANK WATER SUPPLY : COUNTY

PERMIT: CPSF 00 CP * SFD

TYP/SQ	REQUESTED COMPLETED	INSP RESULT	DESCRIPTION RESULTS/COMMENTS
B101 01	5/27/09	DT	R*BLDG FOOTING / TEMP SVC POLE VRU #: 001772367
	5/27/09	AP	
B103 01	5/29/09	DT	R*BLDG FOUND & TEMP SVC POLE VRU #: 001774256
	5/29/09	AP	
A814 01	5/29/09	TI	ADDRESS CONFIRMATION TIME: 17:00 VRU #: 001774249
	6/03/09	AP	638 VALLEY OAK DR LOT 167 BUNNLEVEL 28323
P309 01	6/03/09	MR	R*PLUMB UNDER SLAB VRU #: 001776129
	6/03/09	AP	
B111 01	6/05/09	TI	R*BLDG SLAB INSP VRU #: 001777291

6/5/09 DA D1

----- COMMENTS AND NOTES -----

DO NOT REMOVE!

Harnett County Inspection Department
102 East Front Street • P.O. Box 65
Lillington, NC 27546
Phone: (910) 893-7527 • Fax: (910) 893-2793

Job Name: H4H Date: 6/5/09
Address: 638 Valley Oak Dr
Lot No.: 167 Permit No.: _____

(Check Box for Violation)

- | | | | | | | | |
|--|-------------------------------------|----------------------------------|--|-------------------------------------|---------------------------------------|---------------------------------|--------------------------------------|
| <input type="checkbox"/> Footing | <input type="checkbox"/> Foundation | <input type="checkbox"/> Bldg. | <input type="checkbox"/> Elec. | <input type="checkbox"/> Plumb. | <input type="checkbox"/> Mech. | <input type="checkbox"/> Insul. | <input type="checkbox"/> Floor Fram. |
| <input checked="" type="checkbox"/> Floor Slab | <input type="checkbox"/> MFG. Home | <input type="checkbox"/> Modular | <input type="checkbox"/> Damp/Water Proof. | <input type="checkbox"/> Structural | <input type="checkbox"/> Wall Sheath. | <input type="checkbox"/> Other | |

Violations Found: 1) Repair damage to foundation wall.
2) Plumbing being worked on

Code Enforcement Official _____ Date: _____
Signature: [Handwritten Signature]

It is unlawful for any sub contractor, general contractor, or owner to cover or cause to be covered any part of the work with flooring, sheetrock, earth or other material until the proper inspector had ample time to approve the installation.

ADDRESS : 638 VALLEY OAK DR SUBDIV: FOREST OAKS PH 3 99LOTS
CONTRACTOR : H & H CONSTRUCTORS INC PHONE : (910) 486-4864
OWNER : H&H CONSTRUCTORS, INC PHONE : (910) 486-4864
PARCEL : 01-0536-05- -0028- -54-
APPL NUMBER: 09-50021671 CP NEW RESIDENTIAL (SFD)
DIRECTIONS : FOREST OAKS PH3 #167
TAKE HWY 27 TO NURSERY ROAD, TURN LEFT.
TURN LEFT ON LEMUEL BLACK ROAD. TURN
LEFT ON VALLEY OAK INTO FOREST OAKS.
POWER CO: WAITING ON CUSTOMER
T/S: 03/05/2009 09:44 AM RDCONTE ---

STRUCTURE: 000 000 73.7X54 SLAB 4BED 2BATH W/GAR & DECK
FLOOD ZONE : FLOOD ZONE X
BEDROOMS : 4.00 PROPOSED USE : SFD
SEPTIC - EXISTING? : NEW TANK WATER SUPPLY : COUNTY

PERMIT: CPSF 00 CP * SFD

TYP/SQ	REQUESTED COMPLETED	INSP RESULT	DESCRIPTION RESULTS/COMMENTS
B101 01	5/27/09	DT	R*BLDG FOOTING / TEMP SVC POLE VRU #: 001772367
	5/27/09	AP	
B103 01	5/29/09	DT	R*BLDG FOUND & TEMP SVC POLE VRU #: 001774256
	5/29/09	AP	
A814 01	5/29/09	TI	ADDRESS CONFIRMATION TIME: 17:00 VRU #: 001774249
	6/03/09	AP	638 VALLEY OAK DR LOT 167 BUNNLEVEL 28323
P309 01	6/03/09	MR	R*PLUMB UNDER SLAB VRU #: 001776129
	6/03/09	AP	
B111 01	6/05/09	DT	R*BLDG SLAB INSP VRU #: 001777291
	6/05/09	DA	1. Damage to foundation wall must be repaired.
B111 02	6/08/09	TI	R*BLDG SLAB INSP VRU #: 001778273

6/18/09 AP DT

COMMENTS AND NOTES

ADDRESS : 638 VALLEY OAK DR SUBDIV: FOREST OAKS PH 3 99LOTS
CONTRACTOR : H & H CONSTRUCTORS INC PHONE : (910) 486-4864
OWNER : H&H CONSTRUCTORS, INC PHONE : (910) 486-4864
PARCEL : 01-0536-05- -0028- -54-
APPL NUMBER: 09-50021671 CP NEW RESIDENTIAL (SFD)
DIRECTIONS : FOREST OAKS PH3 #167
TAKE HWY 27 TO NURSERY ROAD, TURN LEFT.
TURN LEFT ON LEMUEL BLACK ROAD. TURN
LEFT ON VALLEY OAK INTO FOREST OAKS.
POWER CO: WAITING ON CUSTOMER
T/S: 03/05/2009 09:44 AM RDCONTE ---

STRUCTURE: 000 000 73.7X54 SLAB 4BED 2BATH W/GAR & DECK
FLOOD ZONE : FLOOD ZONE X
BEDROOMS : 4.00 PROPOSED USE : SFD
SEPTIC - EXISTING? : NEW TANK WATER SUPPLY : COUNTY

PERMIT: CPSF 00 CP * SFD

TYP/SQ	REQUESTED COMPLETED	INSP RESULT	DESCRIPTION RESULTS/COMMENTS
B101 01	5/27/09	DT	R*BLDG FOOTING / TEMP SVC POLE VRU #: 001772367
	5/27/09	AP	
B103 01	5/29/09	DT	R*BLDG FOUND & TEMP SVC POLE VRU #: 001774256
	5/29/09	AP	
A814 01	5/29/09	TI	ADDRESS CONFIRMATION TIME: 17:00 VRU #: 001774249
	6/03/09	AP	638 VALLEY OAK DR LOT 167 BUNNLEVEL 28323
P309 01	6/03/09	MR	R*PLUMB UNDER SLAB VRU #: 001776129
	6/03/09	AP	
B111 01	6/05/09	DT	R*BLDG SLAB INSP VRU #: 001777291
	6/05/09	DA	1. Damage to foundation wall must be repaired.
B111 02	6/08/09	DT	R*BLDG SLAB INSP VRU #: 001778273
	6/08/09	AP	
R427 01	6/26/09	TI	FOUR TRADE ROUGH IN >2500 VRU #: 001787035
	<i>6/26/09</i>	<i>DA DT</i>	

----- COMMENTS AND NOTES -----

ADDRESS : 638 VALLEY OAK DR SUBDIV: FOREST OAKS PH 3 99LOTS
 CONTRACTOR : H & H CONSTRUCTORS INC PHONE : (910) 486-4864
 OWNER : H&H CONSTRUCTORS, INC PHONE : (910) 486-4864
 PARCEL : 01-0536-05- -0028- -54-
 APPL NUMBER: 09-50021671 CP NEW RESIDENTIAL (SFD)
 DIRECTIONS : FOREST OAKS PH3 #167
 TAKE HWY 27 TO NURSERY ROAD, TURN LEFT.
 TURN LEFT ON LEMUEL BLACK ROAD. TURN
 LEFT ON VALLEY OAK INTO FOREST OAKS.
 POWER CO: WAITING ON CUSTOMER
 T/S: 03/05/2009 09:44 AM RDCONTE ---

STRUCTURE: 000 000 73.7X54 SLAB 4BED 2BATH W/GAR & DECK
 FLOOD ZONE : FLOOD ZONE X
 # BEDROOMS : 4.00 PROPOSED USE : SFD
 SEPTIC - EXISTING? : NEW TANK WATER SUPPLY : COUNTY

PERMIT: CPSF 00 CP * SFD

TYP/SQ	REQUESTED COMPLETED	INSP RESULT	DESCRIPTION RESULTS/COMMENTS
B101 01	5/27/09	DT	R*BLDG FOOTING / TEMP SVC POLE VRU #: 001772367
	5/27/09	AP	
B103 01	5/29/09	DT	R*BLDG FOUND & TEMP SVC POLE VRU #: 001774256
	5/29/09	AP	
A814 01	5/29/09	TI	ADDRESS CONFIRMATION TIME: 17:00 VRU #: 001774249
	6/03/09	AP	638 VALLEY OAK DR LOT 167 BUNNLEVEL 28323
P309 01	6/03/09	MR	R*PLUMB UNDER SLAB VRU #: 001776129
	6/03/09	AP	
B111 01	6/05/09	DT	R*BLDG SLAB INSP VRU #: 001777291
	6/05/09	DA	1. Damage to foundation wall must be repaired.
B111 02	6/08/09	DT	R*BLDG SLAB INSP VRU #: 001778273
	6/08/09	AP	
R427 01	6/26/09	DT	FOUR TRADE ROUGH IN >2500 VRU #: 001787035
	6/26/09	DA	Ao2,3, and 4 trusses not strapped properly. Okay to side and insulate. T/S: 06/26/2009 01:13 PM DETAYLOR -----
I129 01	7/06/09	TI	R*INSULATION INSPECTION VRU #: 001789403
	<u>7-6</u>	<u>AP</u>	
R427 02	7/06/09	TI	FOUR TRADE ROUGH IN >2500 VRU #: 001789387
	<u>7-6</u>	<u>AP</u>	

COMMENTS AND NOTES

WPLIFT 603

HOLD DOWN SPF

(1) H2.5A 535

HAND DRIVE NAILS 177

ORIGINALLY 712

Plus (1) H-3 320 (LOOK OUTSIDE?)

NOW

1,032 ✓

JANUARY 31, 2000

TOE-NAIL DETAIL

ST-CON01A

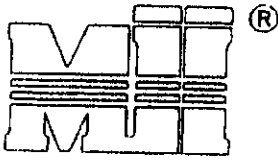

MiTek Industries, Inc.

MiTek Industries, Inc. Chesterfield, MO.

- 1) TOE-NAILS SHALL BE DRIVEN AT AN ANGLE OF 30 DEGREES WITH THE MEMBER AND STARTED 1/3 THE LENGTH OF THE NAIL FROM THE MEMBER END OR AS SHOWN.
- 2) THE PLACEMENT OF THE NAILS SHALL BE SUFFICIENT TO PREVENT SPLITTING OF THE WOOD.

SQUARE CUT

MAXIMUM ALLOWABLE REACTION BASED ON TWO 16d COMMON WIRE NAILS. VALUES BASED ON BOTH MEMBERS OF IDENTICAL SPECIES 15% LOAD DURATION INCREASE

MAXIMUM REACTION:

- SYP = 226 LBS.
- DF = 208 LBS.
- HF = 180 LBS.
- SPF = 177 LBS.

2 X 3 or 2 X 4 MEMBERS

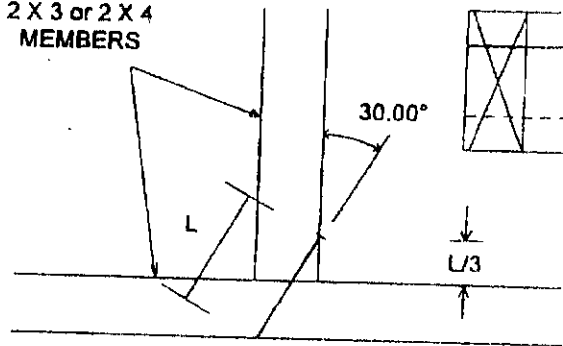

SIDE VIEW

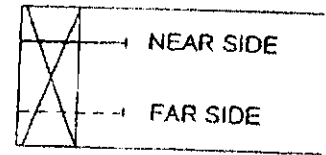

45 DEGREE ANGLE BEVEL CUT

MAXIMUM ALLOWABLE REACTION BASED ON TWO 16d COMMON WIRE NAILS. VALUES BASED ON BOTH MEMBERS OF IDENTICAL SPECIES. 15% LOAD DURATION INCREASE

MAXIMUM REACTION:

- SYP = 226 LBS.
- DF = 208 LBS.
- HF = 180 LBS.
- SPF = 177 LBS.

2 X 3 or 2 X 4 MEMBERS

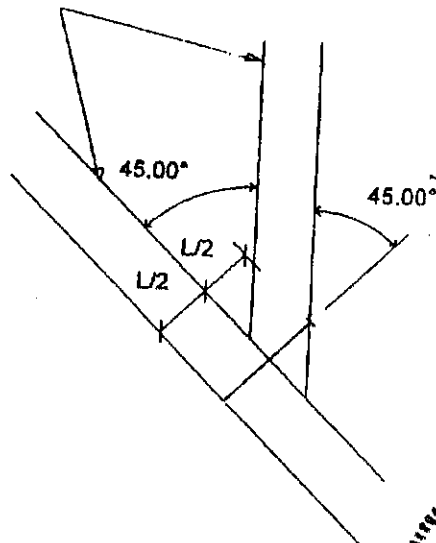

SIDE VIEW

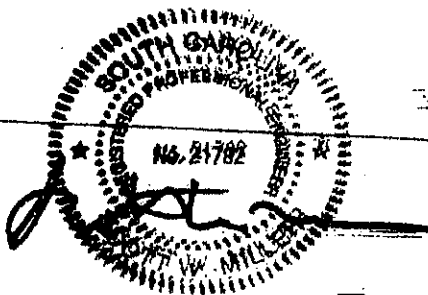
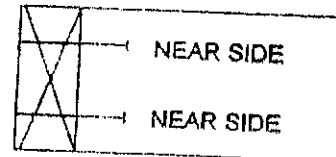

JUN 13 2002

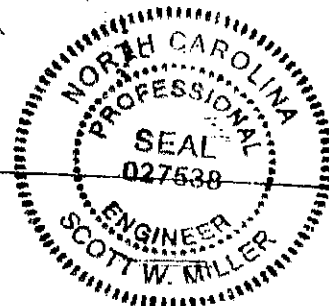

JANUARY 31, 2000

TOE-NAIL DETAIL

ST-CON01A

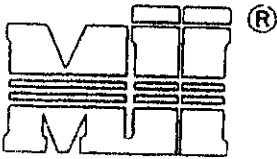

MiTek Industries, Inc.

MiTek Industries, Inc. Chesterfield, MO.

- 1) TOE-NAILS SHALL BE DRIVEN AT AN ANGLE OF 30 DEGREES WITH THE MEMBER AND STARTED 1/3 THE LENGTH OF THE NAIL FROM THE MEMBER END OR AS SHOWN.
- 2) THE PLACEMENT OF THE NAILS SHALL BE SUFFICIENT TO PREVENT SPLITTING OF THE WOOD.

SQUARE CUT

MAXIMUM ALLOWABLE REACTION BASED ON TWO 16d COMMON WIRE NAILS. VALUES BASED ON BOTH MEMBERS OF IDENTICAL SPECIES 15% LOAD DURATION INCREASE

MAXIMUM REACTION:

- SYP = 226 LBS.
- DF = 208 LBS.
- HF = 180 LBS.
- SPF = 177 LBS.

2 X 3 or 2 X 4 MEMBERS

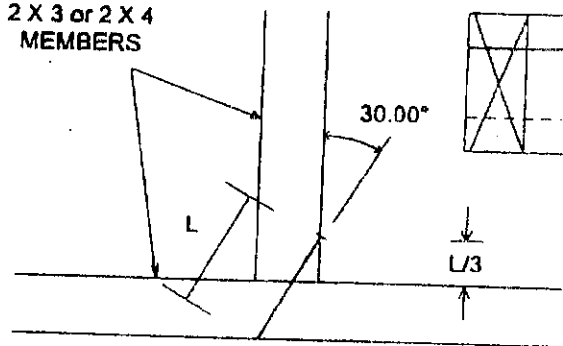

45 DEGREE ANGLE BEVEL CUT

MAXIMUM ALLOWABLE REACTION BASED ON TWO 16d COMMON WIRE NAILS. VALUES BASED ON BOTH MEMBERS OF IDENTICAL SPECIES. 15% LOAD DURATION INCREASE

MAXIMUM REACTION:

- SYP = 226 LBS.
- DF = 208 LBS.
- HF = 180 LBS.
- SPF = 177 LBS.

2 X 3 or 2 X 4 MEMBERS

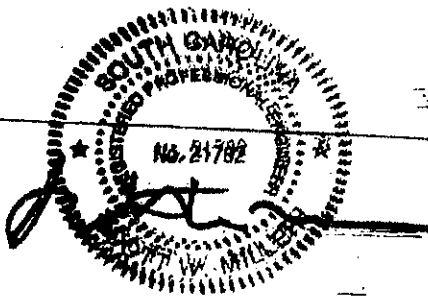
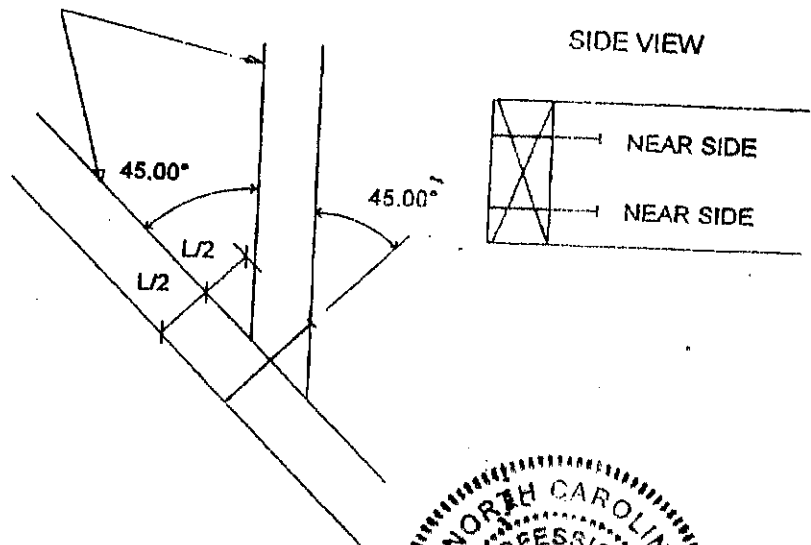

JUN 13 2002

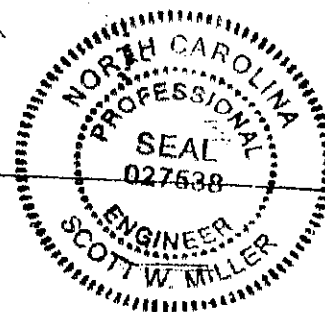

ADDRESS : 638 VALLEY OAK DR SUBDIV: FOREST OAKS PH 3 99LOTS
 CONTRACTOR : H & H CONSTRUCTORS INC PHONE : (910) 486-4864
 OWNER : H&H CONSTRUCTORS, INC PHONE : (910) 486-4864
 PARCEL : 01-0536-05- -0028- -54-
 APPL NUMBER: 09-50021671 CP NEW RESIDENTIAL (SFD)
 DIRECTIONS : FOREST OAKS PH3 #167
 TAKE HWY 27 TO NURSERY ROAD, TURN LEFT.
 TURN LEFT ON LEMUEL BLACK ROAD. TURN
 LEFT ON VALLEY OAK INTO FOREST OAKS.
 POWER CO: WAITING ON CUSTOMER
 T/S: 03/05/2009 09:44 AM RDCONTE ---

STRUCTURE: 000 000 73.7X54 SLAB 4BED 2BATH W/GAR & DECK
 FLOOD ZONE : FLOOD ZONE X
 # BEDROOMS : 4.00 PROPOSED USE : SFD
 SEPTIC - EXISTING? : NEW TANK WATER SUPPLY : COUNTY

PERMIT: CPSF 00 CP * SFD

TYP/SQ	REQUESTED COMPLETED	INSP RESULT	DESCRIPTION RESULTS/COMMENTS
B101 01	5/27/09	DT	R*BLDG FOOTING / TEMP SVC POLE VRU #: 001772367
	5/27/09	AP	
B103 01	5/29/09	DT	R*BLDG FOUND & TEMP SVC POLE VRU #: 001774256
	5/29/09	AP	
A814 01	5/29/09	TI	ADDRESS CONFIRMATION TIME: 17:00 VRU #: 001774249
	6/03/09	AP	✓ 638 VALLEY OAK DR LOT 167 BUNNLEVEL 28323
P309 01	6/03/09	MR	R*PLUMB UNDER SLAB VRU #: 001776129
	6/03/09	AP	
B111 01	6/05/09	DT	R*BLDG SLAB INSP VRU #: 001777291
	6/05/09	DA	1. Damage to foundation wall must be repaired.
B111 02	6/08/09	DT	R*BLDG SLAB INSP VRU #: 001778273
	6/08/09	AP	
R427 01	6/26/09	DT	FOUR TRADE ROUGH IN >2500 VRU #: 001787035
	6/26/09	DA	Ao2,3, and 4 trusses not strapped properly. Okay to side and insulate. T/S: 06/26/2009 01:13 PM DETAYLOR -----
I129 01	7/06/09	KS	R*INSULATION INSPECTION VRU #: 001789403
	7/06/09	AP	
R427 02	7/06/09	KS	FOUR TRADE ROUGH IN >2500 VRU #: 001789387
	7/06/09	AP	
H824 01	8/17/09	JW	✓ ENVIR. OPERATIONS PERMIT TIME: 17:00 VRU #: 001810548
	8/17/09	AP	T/S: 08/18/2009 10:58 AM SSTEWARD ----- T/S: 08/18/2009 10:58 AM SSTEWARD -----
R431 01	8/31/09	TI	FOUR TRADE FINAL >2500 VRU #: 001814920

8-31-9 DP-MR

COMMENTS AND NOTES

HARNETT COUNTY

Building Inspections Dept.

108 E. Front St.

Lillington, NC 27546

910-893-7525

DO NOT REMOVE

DATE: 08-31-09

PERMIT # 09-50021671

ADDRESS: 638 valley oak

VIOLATIONS:

1. Foyer light missing
2. Soffit incomplete by meter
3. Install an intersystem bonding termination at meter
4. Trim incomplete by water spigot next to ac unit
5. Fee \$50

2' Φ

Harnett County Building Department

Mike Rearic cell# (910) 984-4772

Harnett County

INSPECTOR: IVR

DATE 9/02/09

ADDRESS : 638 VALLEY OAK DR SUBDIV: FOREST OAKS PH 3 99LOTS
 CONTRACTOR : H & H CONSTRUCTORS INC PHONE : (910) 486-4864
 OWNER : H&H CONSTRUCTORS, INC PHONE : (910) 486-4864
 PARCEL : 01-0536-05- -0028- -54-
 APPL NUMBER: 09-50021671 CP NEW RESIDENTIAL (SFD)
 DIRECTIONS : FOREST OAKS PH3 #167
 TAKE HWY 27 TO NURSERY ROAD, TURN LEFT.
 TURN LEFT ON LEMUEL BLACK ROAD. TURN
 LEFT ON VALLEY OAK INTO FOREST OAKS.
 POWER CO: WAITING ON CUSTOMER
 T/S: 03/05/2009 09:44 AM RDCONTE ---

STRUCTURE: 000 000 73.7X54 SLAB 4BED 2BATH W/GAR & DECK
 FLOOD ZONE : FLOOD ZONE X
 # BEDROOMS : 4.00 PROPOSED USE : SFD
 SEPTIC - EXISTING? : NEW TANK WATER SUPPLY : COUNTY

PERMIT: CPSF 00 CP * SFD

TYP/SQ	REQUESTED COMPLETED	INSP RESULT	DESCRIPTION RESULTS/COMMENTS
B101 01	5/27/09	DT	R*BLDG FOOTING / TEMP SVC POLE VRU #: 001772367
	5/27/09	AP	
B103 01	5/29/09	DT	R*BLDG FOUND & TEMP SVC POLE VRU #: 001774256
	5/29/09	AP	
A814 01	5/29/09	TI	ADDRESS CONFIRMATION TIME: 17:00 VRU #: 001774249
	6/03/09	AP	✓638 VALLEY OAK DR LOT 167 BUNNLEVEL 28323
P309 01	6/03/09	MR	R*PLUMB UNDER SLAB VRU #: 001776129
	6/03/09	AP	
B111 01	6/05/09	DT	R*BLDG SLAB INSP VRU #: 001777291
	6/05/09	DA	1. Damage to foundation wall must be repaired.
B111 02	6/08/09	DT	R*BLDG SLAB INSP VRU #: 001778273
	6/08/09	AP	
R427 01	6/26/09	DT	FOUR TRADE ROUGH IN >2500 VRU #: 001787035
	6/26/09	DA	Ao2,3, and 4 trusses not strapped properly. Okay to side and insulate. T/S: 06/26/2009 01:13 PM DETAYLOR -----
I129 01	7/06/09	KS	R*INSULATION INSPECTION VRU #: 001789403
	7/06/09	AP	
R427 02	7/06/09	KS	FOUR TRADE ROUGH IN >2500 VRU #: 001789387
	7/06/09	AP	
H824 01	8/17/09	JW	✓ENVIR. OPERATIONS PERMIT TIME: 17:00 VRU #: 001810548
	8/17/09	AP	T/S: 08/18/2009 10:58 AM SSTEWARD ----- T/S: 08/18/2009 10:58 AM SSTEWARD -----
R431 01	8/31/09	MR	FOUR TRADE FINAL >2500 VRU #: 001814920
	8/31/09	DP	T/S: 08/31/2009 10:17 AM MREARIC ----- foyer light missing soffit incomplete over meter install an intersystem bonding termination trim incomplete around spigot by ac unit outlet needed within 2' of counter end ,, left side of sink
R431 02	9/02/09	TI	FOUR TRADE FINAL >2500 VRU #: 001816073
	9-2-9	DP-MR	

----- COMMENTS AND NOTES -----

HARNETT COUNTY

Building Inspections Dept.

108 E. Front St.

Lillington, NC 27546

910-893-7525

DO NOT REMOVE

DATE: 09-02-09

PERMIT # 09-50021671

ADDRESS: 638 valley oak

VIOLATIONS:

1. The wire to the outlet at the end of the counter must be protected and re-routed. (It is rubbing against the drawer)
fee

Harnett County Building Department

Mike Rearic cell# (910) 984- 4772

ADDRESS : 638 VALLEY OAK DR SUBDIV: FOREST OAKS PH 3 99LOTS
 CONTRACTOR : H & H CONSTRUCTORS INC PHONE : (910) 486-4864
 OWNER : H&H CONSTRUCTORS, INC PHONE : (910) 486-4864
 PARCEL : 01-0536-05- -0028- -54-
 APPL NUMBER: 09-50021671 CP NEW RESIDENTIAL (SFD)
 DIRECTIONS : FOREST OAKS PH3 #167
 TAKE HWY 27 TO NURSERY ROAD, TURN LEFT.
 TURN LEFT ON LEMUEL BLACK ROAD. TURN
 LEFT ON VALLEY OAK INTO FOREST OAKS.
 POWER CO: WAITING ON CUSTOMER
 T/S: 03/05/2009 09:44 AM RDCONTE ---

STRUCTURE: 000 000 73.7X54 SLAB 4BED 2BATH W/GAR & DECK
 FLOOD ZONE : FLOOD ZONE X
 # BEDROOMS : 4.00 PROPOSED USE : SFD
 SEPTIC - EXISTING? : NEW TANK WATER SUPPLY : COUNTY

PERMIT: CPSF 00 CP * SFD

TYP/SQ	REQUESTED COMPLETED	INSP RESULT	DESCRIPTION RESULTS/COMMENTS
B101 01	5/27/09	DT	R*BLDG FOOTING / TEMP SVC POLE VRU #: 001772367
	5/27/09	AP	
B103 01	5/29/09	DT	R*BLDG FOUND & TEMP SVC POLE VRU #: 001774256
	5/29/09	AP	
A814 01	5/29/09	TI	ADDRESS CONFIRMATION TIME: 17:00 VRU #: 001774249
	6/03/09	AP	✓638 VALLEY OAK DR LOT 167 BUNNLEVEL 28323
P309 01	6/03/09	MR	R*PLUMB UNDER SLAB VRU #: 001776129
	6/03/09	AP	
B111 01	6/05/09	DT	R*BLDG SLAB INSP VRU #: 001777291
	6/05/09	DA	1. Damage to foundation wall must be repaired.
B111 02	6/08/09	DT	R*BLDG SLAB INSP VRU #: 001778273
	6/08/09	AP	
R427 01	6/26/09	DT	FOUR TRADE ROUGH IN >2500 VRU #: 001787035
	6/26/09	DA	Ao2,3, and 4 trusses not strapped properly. Okay to side and insulate. T/S: 06/26/2009 01:13 PM DETAYLOR -----
I129 01	7/06/09	KS	R*INSULATION INSPECTION VRU #: 001789403
	7/06/09	AP	
R427 02	7/06/09	KS	FOUR TRADE ROUGH IN >2500 VRU #: 001789387
	7/06/09	AP	
H824 01	8/17/09	JW	✓ENVIR. OPERATIONS PERMIT TIME: 17:00 VRU #: 001810548
	8/17/09	AP	T/S: 08/18/2009 10:58 AM SSTEWARD ----- T/S: 08/18/2009 10:58 AM SSTEWARD -----
R431 01	8/31/09	MR	FOUR TRADE FINAL >2500 VRU #: 001814920
	8/31/09	DP	T/S: 08/31/2009 10:17 AM MREARIC ----- foyer light missing soffit incomplete over meter install an intersystem bonding termination trim incomplete around spigot by ac unit outlet needed within 2' of counter end ,, left side of sink
R431 02	9/02/09	MR	FOUR TRADE FINAL >2500 VRU #: 001816073
	9/02/09	DP	T/S: 09/02/2009 10:30 AM MREARIC ----- reroute and protect the wire to the outlet at the end of the counter, it rubs against the drawer

PREPARED 9/02/09, 13:59:34
Harnett County

INSPECTION TICKET
INSPECTOR: IVR

PAGE 8
DATE 9/03/09

ADDRESS . : 638 VALLEY OAK DR SUBDIV: FOREST OAKS PH 3 99LOTS
CONTRACTOR : H & H CONSTRUCTORS INC PHONE : (910) 486-4864
OWNER . . : H&H CONSTRUCTORS, INC PHONE : (910) 486-4864
PARCEL . . : 01-0536-05- -0028- -54-
APPL NUMBER: 09-50021671 CP NEW RESIDENTIAL (SFD)

TYP/SQ	REQUESTED COMPLETED	INSP RESULT	DESCRIPTION RESULTS/COMMENTS
R431 03	9/03/09 <u>9-3-09</u>	TI <u>AP JH</u>	FOUR TRADE FINAL >2500 VRU #: 001816883

----- COMMENTS AND NOTES -----

**COUNTY OF HARNETT
DEPARTMENT OF BUILDING INSPECTION
AND PLANNING/DEVELOPMENT
CERTIFICATE OF OCCUPANCY**

This certificate issued pursuant to the requirements of Section 105 of the North Carolina State Building Code and the Harnett County Zoning Ordinance certifies at the time of issuance this structure was in compliance with the various ordinances of the County of Harnett regulating development and building construction or use. For the following:

Use Classification: SFD

Owner: H & H Construction

911 Address: 638 Valley Park Dr

State: A.C. Zip Code: _____

Date: 4-3-09

James Hill
Building Official

PERMIT NUMBERS

Building Permit No.: _____

Electrical Permit No.: _____

Insulation Permit No.: _____

Plumbing Permit No.: _____

Mech. Permit No.: _____

MFG. Home: _____

1194002671