

PREPARED 6/23/08, 14:40:34
Harnett County

INSPECTION TICKET
INSPECTOR: IVR

PAGE 1
DATE 6/24/08

ADDRESS . . : 157 CAROLINA OAKS CIR SUBDIV: CAROLINA OAKS 64 LOTS
CONTRACTOR : BILL CLARK HOMES LLC PHONE : (252) 355-5805
OWNER . . : BILL CLARK HOMES OF FAYETTEVIL PHONE : (910) 426-2898
PARCEL . . : 01-0544- - -0012- -48-
APPL NUMBER: 08-50020180 CP NEW RESIDENTIAL (SFD)

DIRECTIONS : CAROLINA OAKS #47-401 RT ON ELLIOTT
BRIDGE RT ON WILL LUCAS RT INTO S/D.JD

STRUCTURE: 000 000 65X40 4BR W/GARAGE
FLOOD ZONE : FLOOD ZONE X

PERMIT: CPSF 00 CP * SFD

TYP/SQ	REQUESTED COMPLETED	INSP RESULT	DESCRIPTION RESULTS/COMMENTS	TIME	VRU #
B101 01	6/24/08	TI <i>AP JH</i>	R*BLDG FOOTING / TEMP SVC POLE	17:00	001631068

----- COMMENTS AND NOTES -----

ADDRESS . : 157 CAROLINA OAKS CIR SUBDIV: CAROLINA OAKS 64 LOTS
CONTRACTOR : BILL CLARK HOMES LLC PHONE : (252) 355-5805
OWNER . . : BILL CLARK HOMES OF FAYETTEVIL PHONE : (910) 426-2898
PARCEL . . : 01-0544- - -0012- -48-
APPL NUMBER: 08-50020180 CP NEW RESIDENTIAL (SFD)
DIRECTIONS : CAROLINA OAKS #47-401 RT ON ELLIOTT
BRIDGE RT ON WILL LUCAS RT INTO S/D.JD

STRUCTURE: 000 000 65X40 4BR W/GARAGE
FLOOD ZONE : FLOOD ZONE X

PERMIT: CPSF 00 CP * SFD

TYP/SQ	REQUESTED COMPLETED	INSP RESULT	DESCRIPTION RESULTS/COMMENTS
B101 01	6/24/08 6/24/08	JH AP	R*BLDG FOOTING / TEMP SVC POLE TIME: 17:00 VRU #: 001631068
B103 01	6/26/08	TI <i>AP JH</i>	R*BLDG FOUND & TEMP SVC POLE VRU #: 001632488

----- COMMENTS AND NOTES -----

ADDRESS . . : 157 CAROLINA OAKS CIR SUBDIV: CAROLINA OAKS 64 LOTS
CONTRACTOR : BILL CLARK HOMES LLC PHONE : (252) 355-5805
OWNER . . . : BILL CLARK HOMES OF FAYETTEVIL PHONE : (910) 426-2898
PARCEL . . . : 01-0544- - -0012- -48-
APPL NUMBER: 08-50020180 CP NEW RESIDENTIAL (SFD)
DIRECTIONS : CAROLINA OAKS #47-401 RT ON ELLIOTT
BRIDGE RT ON WILL LUCAS RT INTO S/D.JD

STRUCTURE: 000 000 65X40 4BR W/GARAGE
FLOOD ZONE : FLOOD ZONE X

PERMIT: CPSF 00 CP * SFD

TYP/SQ	REQUESTED COMPLETED	INSP RESULT	DESCRIPTION RESULTS/COMMENTS
B101 01	6/24/08 6/24/08	JH AP	R*BLDG FOOTING / TEMP SVC POLE TIME: 17:00 VRU #: 001631068
B103 01	6/26/08 6/26/08	JH AP	R*BLDG FOUND & TEMP SVC POLE VRU #: 001632488
A814 01	7/01/08	TI	ADDRESS CONFIRMATION VRU #: 001632512
P309 01	7/01/08	TI <i>DA JH</i>	R*PLUMB UNDER SLAB VRU #: 001634958

----- COMMENTS AND NOTES -----

ADDRESS : 157 CAROLINA OAKS CIR SUBDIV: CAROLINA OAKS 64 LOTS
CONTRACTOR : BILL CLARK HOMES LLC PHONE : (252) 355-5805
OWNER : BILL CLARK HOMES OF FAYETTEVILLE PHONE : (910) 426-2898
PARCEL : 01-0544- - -0012- -48-
APPL NUMBER: 08-50020180 CP NEW RESIDENTIAL (SFD)
DIRECTIONS : CAROLINA OAKS #47-401 RT ON ELLIOTT
BRIDGE RT ON WILL LUCAS RT INTO S/D.JD

STRUCTURE: 000 000 65X40 4BR W/GARAGE
FLOOD ZONE : FLOOD ZONE X

PERMIT: CPSF 00 CP * SFD

TYP/SQ	REQUESTED COMPLETED	INSP RESULT	DESCRIPTION RESULTS/COMMENTS
B101 01	6/24/08 6/24/08	JH AP	R*BLDG FOOTING / TEMP SVC POLE TIME: 17:00 VRU #: 001631068
B103 01	6/26/08 6/26/08	JH AP	R*BLDG FOUND & TEMP SVC POLE VRU #: 001632488
A814 01	7/01/08	TI	ADDRESS CONFIRMATION VRU #: 001632512
P309 01	7/01/08 7/01/08	JH DA	R*PLUMB UNDER SLAB VRU #: 001634958 X) Need 10' head of water for under slab plumbing. X) Need to bed pipe properly. X) Seal sleeve @ foundation wall.
P309 02	7/02/08	TI AP JH	R*PLUMB UNDER SLAB VRU #: 001635644

----- COMMENTS AND NOTES -----

ADDRESS : 157 CAROLINA OAKS CIR SUBDIV: CAROLINA OAKS 64 LOTS
CONTRACTOR : BILL CLARK HOMES LLC PHONE : (252) 355-5805
OWNER : BILL CLARK HOMES OF FAYETTEVILLE PHONE : (910) 426-2898
PARCEL : 01-0544- - -0012- -48-
APPL NUMBER: 08-50020180 CP NEW RESIDENTIAL (SFD)
DIRECTIONS : CAROLINA OAKS #47-401 RT ON ELLIOTT
BRIDGE RT ON WILL LUCAS RT INTO S/D.JD

STRUCTURE: 000 000 65X40 4BR W/GARAGE
FLOOD ZONE : FLOOD ZONE X

PERMIT: CPSF 00 CP * SFD

TYP/SQ	REQUESTED COMPLETED	INSP RESULT	DESCRIPTION RESULTS/COMMENTS
B101 01	6/24/08 6/24/08	JH AP	R*BLDG FOOTING / TEMP SVC POLE TIME: 17:00 VRU #: 001631068
B103 01	6/26/08 6/26/08	JH AP	R*BLDG FOUND & TEMP SVC POLE VRU #: 001632488
P309 01	7/01/08 7/01/08	JH DA	R*PLUMB UNDER SLAB VRU #: 001634958 1)Need 10' head of water for under slab plumbing. 2)Need to bed pipe properly. 3)Seal sleeve @ foundation wall.
A814 01	7/01/08 7/03/08	TI AP	ADDRESS CONFIRMATION TIME: 17:00 VRU #: 001632512 157 CAROLINA OAKS CIR LOT 48
P309 02	7/02/08 7/02/08	JH AP	R*PLUMB UNDER SLAB VRU #: 001635644
B111 01	7/07/08 7/07/08	JH AP	R*BLDG SLAB INSP VRU #: 001636698
R425 01	8/04/08 8/04/08	JH CA	FOUR TRADE ROUGH IN VRU #: 001654962 per Paul
R425 02	8/06/08	TI	FOUR TRADE ROUGH IN VRU #: 001656867

DA JH

----- COMMENTS AND NOTES -----

This truss is repaired to stub 3-1/2" off left end of truss as shown.

Refer to drawing R6680 073333017 for plates and other data not given here.

Repair(s) must comply with Alpine designs & specifications

Shore Truss and any supported spans in proper position as repair is being made.

++ USE A SHARP METAL CUTTING SAW BLADE TO CAREFULLY REMOVE MATERIAL FROM THE TRUSS AS SHOWN. REMAINING PORTIONS OF TRUSS AND ALPINE PLATES MUST BE FREE FROM DAMAGE AND FULLY EMBEDDED INTO TRUSS MEMBERS.

(A) (2) 2X4X 7-0-0 SP#2 AS SHOWN; ATTACH TO EACH FACE OF TRUSS WITH 10d BOX(0.128"X3.0") NAILS @ 8"OC WITHOUT SPLITTING LUMBER

*1 (1) 2X6 SP #2 OR BETTER CUT-TO-FIT FIELD-INSTALLED MEMBER TO BE ADDED AS SHOWN INTO PLANE OF TRUSS. TOTAL OF (1) MEMBER(S) TO BE ADDED IN PLANE.

(B) (2) 3/4" (NOM.)x2-11-1 x4-10-5 APA 48/24 RATED SHEATHING (PLYWOOD OR OSB) GUSSETS REQUIRED. APPLY ONE GUSSET TO EACH FACE LOCATED AS SHOWN, AND ATTACH WITH 0.099X2.0" (6d BOX)NAILS AS SHOWN BY NAIL CIRCLES. GUSSET MAY BE TRIMMED TO FIT TRUSS PROFILE AND NOTCHED TO FIT HANGER.

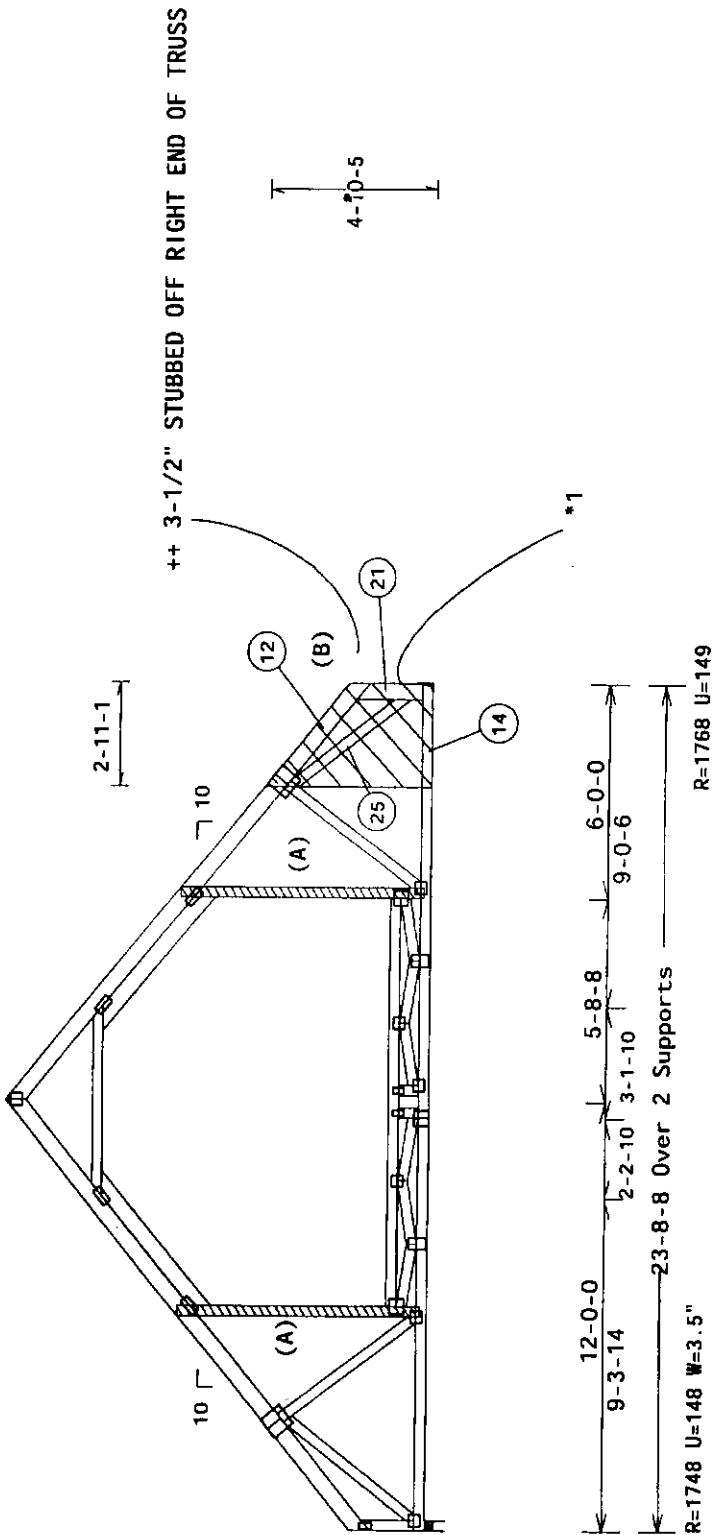

Note: All Plates Are 4X4 Except As Shown.

PLT TYP. Wave TPI

Design Crit: IBC CODE

TRUSS REPAIR

DAMAGED TRUSSES MUST BE CAREFULLY EVALUATED TO DETERMINE THE EXTENT OF DAMAGE AND THE FEASIBILITY OF REPAIR. IN SOME CASES THE PRUDENT SOLUTION IS TO SCRAP THE DAMAGED TRUSSES AND REBUILD. INTERNAL WOOD FIBER DAMAGE AND EXCESSIVE CONNECTOR STRESS FROM BENDING OR SHOCK CANNOT BE READILY DETECTED. THEREFORE, IT IS VITAL THAT THE TRUSS FABRICATOR AND BUILDING CONTRACTOR CONSIDER THE CAUSE OF THE DAMAGE IN THEIR DECISION WHETHER TO REPAIR OR REBUILD.

REPAIR WORK SHOWN ON THIS DRAWING APPLIES ONLY TO THOSE SECTIONS OF THE TRUSS REPORTED BY THE TRUSS MANUFACTURER TO HAVE BEEN DAMAGED. A QUALIFIED THIRD PARTY INSPECTOR SHALL CHECK TRUSSES TO DETERMINE THE EXTENT OF ANY FURTHER DAMAGE, IF ANY, AND VERIFY THAT REPAIRS HAVE BEEN PERFORMED AS INDICATED ON THIS DRAWING.

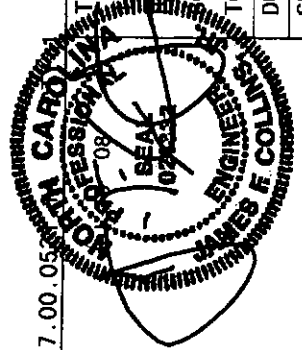
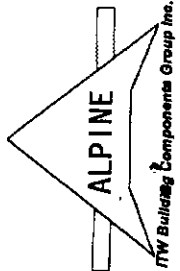

Scale = .1875"/Ft.	REF R6680- 16084
NC/-/1/-/-/R/F	DATE 07/15/08
20.0 PSF	DRW HCUR6680 08187091
10.0 PSF	HC-ENG JB/DL
10.0 PSF	SEQN- 11034
0.0 PSF	FROM EZC
TOT. LD. 40.0 PSF	JREF- 1TJ86680Z11
DUR. FAC. 1.15	
SPACING 24.0"	

ADDRESS : 157 CAROLINA OAKS CIR
 CONTRACTOR : BILL CLARK HOMES LLC
 OWNER : BILL CLARK HOMES OF FAYETTEVILLE
 PARCEL : 01-0544- - -0012- -48-
 APPL NUMBER: 08-50020180 CP NEW RESIDENTIAL (SFD)
 DIRECTIONS : CAROLINA OAKS #47-401 RT ON ELLIOTT
 BRIDGE RT ON WILL LUCAS RT INTO S/D.JD

SUBDIV: CAROLINA OAKS 64 LOTS
 PHONE : (252) 355-5805
 PHONE : (910) 426-2898

STRUCTURE: 000 000 65X40 4BR W/GARAGE
 FLOOD ZONE : FLOOD ZONE X

PERMIT: CPSF 00 CP * SFD

TYP/SQ	REQUESTED COMPLETED	INSP RESULT	DESCRIPTION RESULTS/COMMENTS
B101 01	6/24/08 6/24/08	JH AP	R*BLDG FOOTING / TEMP SVC POLE TIME: 17:00 VRU #: 001631068
B103 01	6/26/08 6/26/08	JH AP	R*BLDG FOUND & TEMP SVC POLE VRU #: 001632488
P309 01	7/01/08 7/01/08	JH DA	R*PLUMB UNDER SLAB VRU #: 001634958 1)Need 10' head of water for under slab plumbing. 2)Need to bed pipe properly. 3)Seal sleeve @ foundation wall.
A814 01	7/01/08 7/03/08	TI AP	ADDRESS CONFIRMATION TIME: 17:00 VRU #: 001632512 157 CAROLINA OAKS CIR LOT 48
P309 02	7/02/08 7/02/08	JH AP	R*PLUMB UNDER SLAB VRU #: 001635644
B111 01	7/07/08 7/07/08	JH AP	R*BLDG SLAB INSP VRU #: 001636698
R425 01	8/04/08 8/04/08	JH CA	FOUR TRADE ROUGH IN VRU #: 001654962 per Paul
R425 02	8/06/08 8/06/08	JH DA	FOUR TRADE ROUGH IN VRU #: 001656867 1) Flex duct 14' max in spare bath & not hooked up. 2) Fire caulk holes in top plate over fire place. 3) 3foot head of water on drain line. 4) Missing stud @ top of stairs on left side. 5) Strap trunk line duct on each end. 6) Nail truss C4G per drawings 2ply.
R425 03	8/08/08	TI AP JH	FOUR TRADE ROUGH IN VRU #: 001658954

COMMENTS AND NOTES

ADDRESS : 157 CAROLINA OAKS CIR SUBDIV: CAROLINA OAKS 64 LOTS
CONTRACTOR : BILL CLARK HOMES LLC PHONE : (252) 355-5805
OWNER : BILL CLARK HOMES OF FAYETTEVILLE PHONE : (910) 426-2898
PARCEL : 01-0544- - -0012- -48-
APPL NUMBER: 08-50020180 CP NEW RESIDENTIAL (SFD)
DIRECTIONS : CAROLINA OAKS #47-401 RT ON ELLIOTT
BRIDGE RT ON WILL LUCAS RT INTO S/D.JD

STRUCTURE: 000 000 65X40 4BR W/GARAGE
FLOOD ZONE : FLOOD ZONE X

PERMIT: CPSF 00 CP * SFD

TYP/SQ	REQUESTED COMPLETED	INSP RESULT	DESCRIPTION RESULTS/COMMENTS
B101 01	6/24/08 6/24/08	JH AP	R*BLDG FOOTING / TEMP SVC POLE TIME: 17:00 VRU #: 001631068
B103 01	6/26/08 6/26/08	JH AP	R*BLDG FOUND & TEMP SVC POLE VRU #: 001632488
P309 01	7/01/08 7/01/08	JH DA	R*PLUMB UNDER SLAB VRU #: 001634958 1)Need 10' head of water for under slab plumbing. 2)Need to bed pipe properly. 3)Seal sleeve @ foundation wall.
AB14 01	7/01/08 7/03/08	TI AP	ADDRESS CONFIRMATION TIME: 17:00 VRU #: 001632512 157 CAROLINA OAKS CIR LOT 48
P309 02	7/02/08 7/02/08	JH AP	R*PLUMB UNDER SLAB VRU #: 001635644
B111 01	7/07/08 7/07/08	JH AP	R*BLDG SLAB INSP VRU #: 001636698
R425 01	8/04/08 8/04/08	JH CA	FOUR TRADE ROUGH IN VRU #: 001654962 per Paul
R425 02	8/06/08 8/06/08	JH DA	FOUR TRADE ROUGH IN VRU #: 001656867 1)Flex duct 14' max in spare bath & not hooked up. 2)Fire caulk holes in top plate over fire place. 3)3foot head of water on drain line. 4)Missing stud @ top of stairs on left side. 5)Strap trunk line duct on each end. 6)Nail truss C4G per drawings 2ply.
R425 03	8/08/08 8/08/08	JH AP	FOUR TRADE ROUGH IN VRU #: 001658954
I129 01	8/11/08	TI	R*INSULATION INSPECTION VRU #: 001659945

DA JH
not Ready

COMMENTS AND NOTES

ADDRESS : 157 CAROLINA OAKS CIR SUBDIV: CAROLINA OAKS 64 LOTS
 CONTRACTOR : BILL CLARK HOMES LLC PHONE : (252) 355-5805
 OWNER : BILL CLARK HOMES OF FAYETTEVILLE PHONE : (910) 426-2898
 PARCEL : 01-0544- - -0012- -48-
 APPL NUMBER: 08-50020180 CP NEW RESIDENTIAL (SFD)
 DIRECTIONS : CAROLINA OAKS #47-401 RT ON ELLIOTT
 BRIDGE RT ON WILL LUCAS RT INTO S/D.JD

STRUCTURE: 000 000 65X40 4BR W/GARAGE
 FLOOD ZONE : FLOOD ZONE X

PERMIT: CPSF 00 CP * SFD

TYP/SQ	REQUESTED COMPLETED	INSP RESULT	DESCRIPTION RESULTS/COMMENTS
B101 01	6/24/08 6/24/08	JH AP	R*BLDG FOOTING / TEMP SVC POLE TIME: 17:00 VRU #: 001631068
B103 01	6/26/08 6/26/08	JH AP	R*BLDG FOUND & TEMP SVC POLE VRU #: 001632488
P309 01	7/01/08 7/01/08	JH DA	R*PLUMB UNDER SLAB VRU #: 001634958 1)Need 10' head of water for under slab plumbing. 2)Need to bed pipe properly. 3)Seal sleeve @ foundation wall.
A814 01	7/01/08 7/03/08	TI AP	ADDRESS CONFIRMATION TIME: 17:00 VRU #: 001632512 157 CAROLINA OAKS CIR LOT 48
P309 02	7/02/08 7/02/08	JH AP	R*PLUMB UNDER SLAB VRU #: 001635644
B111 01	7/07/08 7/07/08	JH AP	R*BLDG SLAB INSP VRU #: 001636698
R425 01	8/04/08 8/04/08	JH CA	FOUR TRADE ROUGH IN VRU #: 001654962 per Paul
R425 02	8/06/08 8/06/08	JH DA	FOUR TRADE ROUGH IN VRU #: 001656867 1)Flex duct 14' max in spare bath & not hooked up. 2)Fire caulk holes in top plate over fire place. 3)3foot head of water on drain line. 4)Missing stud @ top of stairs on left side. 5)Strap trunk line duct on each end. 6)Nail truss C4G per drawings 2ply.
R425 03	8/08/08 8/08/08	JH AP	FOUR TRADE ROUGH IN VRU #: 001658954
I129 01	8/11/08 8/11/08	JH DA	R*INSULATION INSPECTION VRU #: 001659945 not ready
I129 02	8/12/08 <u>8/12/08</u>	TI <u>AP DT</u>	R*INSULATION INSPECTION VRU #: 001660596

COMMENTS AND NOTES

ADDRESS : 157 CAROLINA OAKS CIR
CONTRACTOR : BILL CLARK HOMES LLC
OWNER : BILL CLARK HOMES OF FAYETTEVIL
PARCEL : 01-0544- - -0012- -48-
APPL NUMBER: 08-50020180 CP NEW RESIDENTIAL (SFD)
DIRECTIONS : CAROLINA OAKS #47-401 RT ON ELLIOTT
BRIDGE RT ON WILL LUCAS RT INTO S/D.JD

SUBDIV: CAROLINA OAKS 64 LOTS
PHONE : (252) 355-5805
PHONE : (910) 426-2898

STRUCTURE: 000 000 65X40 4BR W/GARAGE

FLOOD ZONE : FLOOD ZONE X
BEDROOMS : 4.00 PROPOSED USE : SFD
SEPTIC - EXISTING? : NEW

PERMIT: CPSF 00 CP * SFD

TYP/SQ	REQUESTED COMPLETED	INSP RESULT	DESCRIPTION RESULTS/COMMENTS
B101 01	6/24/08	JH	R*BLDG FOOTING / TEMP SVC POLE TIME: 17:00 VRU #: 001631068
	6/24/08	AP	
B103 01	6/26/08	JH	R*BLDG FOUND & TEMP SVC POLE VRU #: 001632488
	6/26/08	AP	
P309 01	7/01/08	JH	R*PLUMB UNDER SLAB VRU #: 001634958
	7/01/08	DA	1)Need 10' head of water for under slab plumbing. 2)Need to bed pipe properly. 3)Seal sleeve @ foundation wall.
A814 01	7/01/08	TI	ADDRESS CONFIRMATION TIME: 17:00 VRU #: 001632512
	7/03/08	AP	✓ 157 CAROLINA OAKS CIR LOT 48
P309 02	7/02/08	JH	R*PLUMB UNDER SLAB VRU #: 001635644
	7/02/08	AP	
B111 01	7/07/08	JH	R*BLDG SLAB INSP VRU #: 001636698
	7/07/08	AP	
R425 01	8/04/08	JH	FOUR TRADE ROUGH IN VRU #: 001654962
	8/04/08	CA	per Paul
R425 02	8/06/08	JH	FOUR TRADE ROUGH IN VRU #: 001656867
	8/06/08	DA	1)Flex duct 14' max in spare bath & not hooked up. 2)Fire caulk holes in top plate over fire place. 3)3foot head of water on drain line. 4)Missing stud @ top of stairs on left side. 5)Strap trunk line duct on each end. 6)Nail truss C4G per drawings 2ply.
R425 03	8/08/08	JH	FOUR TRADE ROUGH IN VRU #: 001658954
	8/08/08	AP	
I129 01	8/11/08	JH	R*INSULATION INSPECTION VRU #: 001659945
	8/11/08	DA	not ready
I129 02	8/12/08	DT	R*INSULATION INSPECTION VRU #: 001660596
	8/12/08	AP	
H824 01	8/20/08	OT	✓ ENVIR. OPERATIONS PERMIT TIME: 17:00 VRU #: 001666247
	8/20/08	AP	
R429 01	10/17/08	TI	FOUR TRADE FINAL VRU #: 001693411

AP JH

COMMENTS AND NOTES

**COUNTY OF HARNETT
DEPARTMENT OF BUILDING INSPECTION
AND PLANNING/DEVELOPMENT
CERTIFICATE OF OCCUPANCY**

This certificate issued pursuant to the requirements of Section 105 of the North Carolina State Building Code and the Harnett County Zoning Ordinance certifies at the time of issuance this structure was in compliance with the various ordinances of the County of Harnett regulating development and building construction or use. For the following:

Use Classification: SFD

Owner: Bill Clark Jones

911 Address: 157 Caroline Oaks Cir

State: _____ Zip Code: _____

Date: 10-17-08
James [Signature]
Building Official

PERMIT NUMBERS

Building Permit No.: _____

Electrical Permit No.: _____

Insulation Permit No.: _____

Plumbing Permit No.: _____

Mech. Permit No.: _____

MFG. Home: _____

OK 5020190