

HTE# 08-500-19804R

Harnett County Department of Public Health

24693

Improvement Permit

A building permit cannot be issued with only an Improvement Permit

ISSUED TO: Kent Pierce PROPERTY LOCATION: Hoover Rd
 SUBDIVISION: Persimmon Hill LOT # 18
 NEW REPAIR EXPANSION
 Type of Structure: SFD-36x61-3BR Site Improvements required prior to Construction Authorization Issuance:
 Proposed Wastewater System Type: Pump to 25% Red sig
 Projected Daily Flow: 360 GPD
 Number of bedrooms: 3 Number of Occupants: 6 max
 Basement Yes No
 Pump Required: Yes No May be required based on final location and elevations of facilities
 Type of Water Supply: Community Public Well Distance from well 50 feet Permit valid for: Five years
 Permit conditions: Meet onsite maintain all set back No expiration

Authorized State Agent: J. L. W. W. Date: 04-18-08 SEE ATTACHED SITE SKETCH
 The issuance of this permit by the Health Department in no way guarantees the issuance of other permits. The permit holder is responsible for checking with appropriate governing bodies in meeting their requirements. This site is subject to revocation if the site plan, plat, or the intended use changes. The Improvement Permit shall not be affected by a change in ownership of the site. This permit is subject to compliance with the provisions of the Laws and Rules for Sewage Treatment and Disposal and to conditions of this permit.

Construction Authorization

(Required for Building Permit)

The construction and installation requirements of Rules .1950, .1952, .1954, .1955, .1956, .1957, .1958, and .1959 are incorporated by references into this permit and shall be met. Systems shall be installed in accordance with the attached system layout.

ISSUED TO: Kent Pierce PROPERTY LOCATION: Hoover Rd
 SUBDIVISION: Persimmon Hill LOT # 18
 Facility Type: SFD-36x61-3BR New Expansion Repair
 Basement? Yes No Basement Fixtures? Yes No
 Type of Wastewater System** Pump to 25% Red sig (Initial) Wastewater Flow: _____ GPD
 (See note below, if applicable) LPP (Repair)

Installation Requirements/Conditions

Septic Tank Size 1000 gallons Exact length of each trench 1x180 feet Trench Spacing: 9 Feet on Center
 Pump Tank Size 1000 gallons Trenches shall be installed on contour at a Soil Cover: 6 inches
 Maximum Trench Depth of: 18 inches (Maximum soil cover shall not exceed 36" above the trench bottom)
 Pump Requirements: _____ ft. TDH vs. _____ GPM Aggregate Depth: _____ inches below pipe
 Conditions: _____ inches above pipe
 _____ inches total

**If applicable: I understand the system type specified is different from the type specified on the application. I accept the specifications of this permit.

Owner/Legal Representative Signature: _____ Date: _____

This Construction Authorization is subject to revocation if the site plan, plat, or the intended use changes. The Construction Authorization shall not be transferred when there is a change in ownership of the site. This Construction Authorization is subject to compliance with the provisions of the Laws and Rules for Sewage Treatment and Disposal and to the conditions of this permit.

Authorized State Agent: J. L. W. W. Date: 04-18-08 SEE ATTACHED SITE SKETCH
 Construction Authorization Expiration Date: 04-18-2013

HTE# 08-500-19824

Permit # 24693

Harnett County Department of Public Health Site Sketch

ISSUED TO: Kent Pizze

PROPERTY LOCATOR: Hoover Rd

SUBDIVISION: Persimmon Hill

LOT # 18

Authorized State Agent: J. [Signature]

Date: 04-18-08

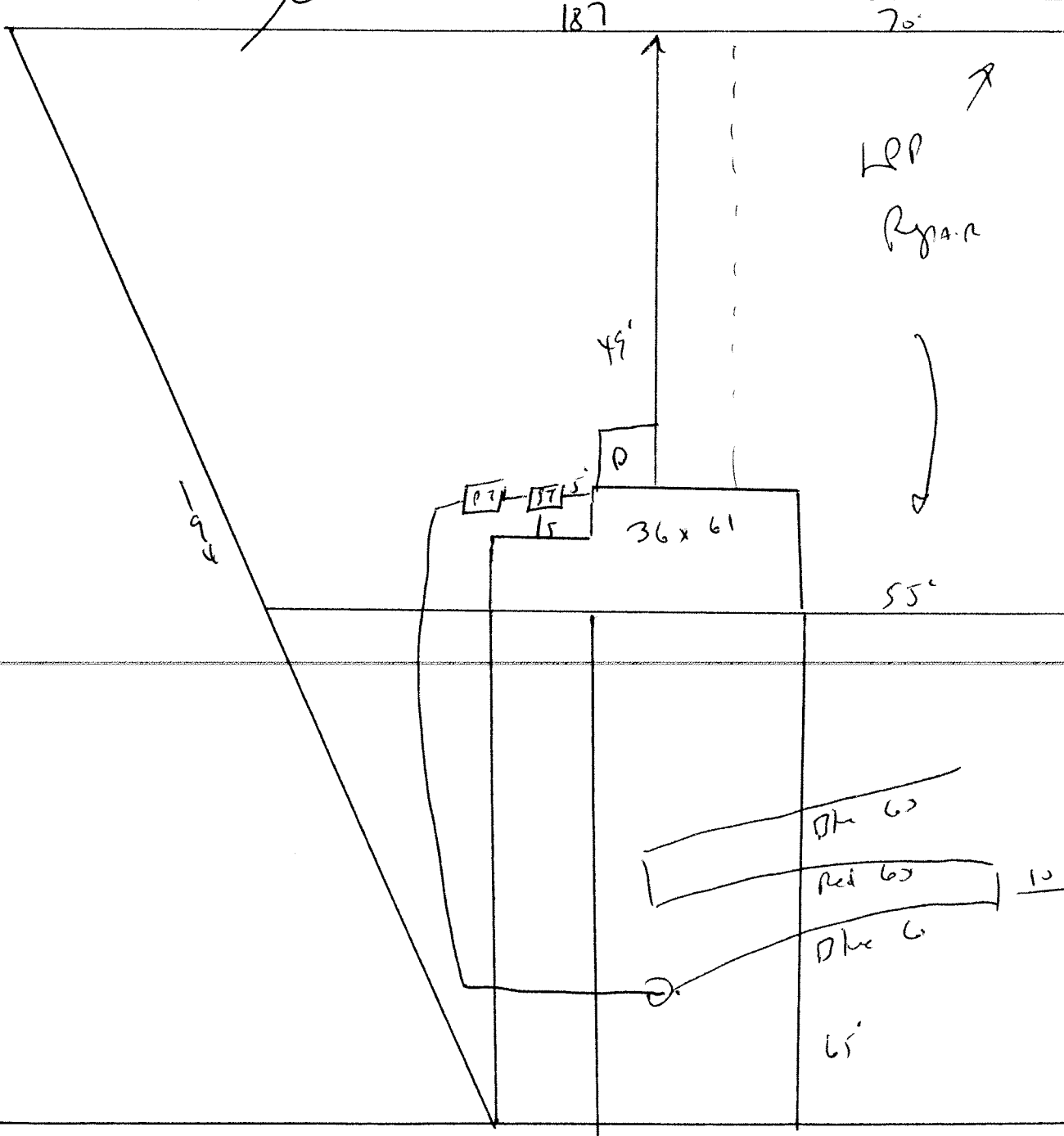

Meet onsite
 Maintain
 All
 set Backs
 Do not
 Drive
 or park
 on any
 Part of
 Septic
 SYSTEM

Install
 1x180
 425%
 Reduction
 SYSTEM
 At 18"

LEP
 Repair