

HTE# 07-50018134

Harnell County Department of Public Health

24265

Improvement Permit

A building permit cannot be issued with only an Improvement Permit

ISSUED TO: ISRAEL LUCAS PROPERTY LOCATION: 1141
 SUBDIVISION: Sunset Ridge LOT # 165
 NEW REPAIR EXPANSION
 Type of Structure: SFD-56x54-3BR Site Improvements required prior to Construction Authorization Issuance:
 Proposed Wastewater System Type: 25% Reduction system
 Projected Daily Flow: 360 GPD
 Number of bedrooms: 3 Number of Occupants: 6 max
 Basement Yes No
 Pump Required: Yes No May be required based on final location and elevations of facilities
 Type of Water Supply: Community Public Well Distance from well 50 feet Permit valid for: Five years
 Permit conditions: STUB out Plumbing shallow at ground level or higher No expiration
Where shown maintain all setbacks.

Authorized State Agent: J. Lucas Date: 08-10-07 SEE ATTACHED SITE SKETCH
 The issuance of this permit by the Health Department in no way guarantees the issuance of other permits. The permit holder is responsible for checking with appropriate governing bodies in meeting their requirements. This site is subject to revocation if the site plan, plat, or the intended use changes. The Improvement Permit shall not be affected by a change in ownership of the site. This permit is subject to compliance with the provisions of the Laws and Rules for Sewage Treatment and Disposal and to conditions of this permit.

Construction Authorization

(Required for Building Permit)

The construction and installation requirements of Rules .1950, .1952, .1954, .1955, .1956, .1957, .1958, and .1959 are incorporated by references into this permit and shall be met. Systems shall be installed in accordance with the attached system layout.

ISSUED TO: ISRAEL LUCAS PROPERTY LOCATION: 1141
 SUBDIVISION: SUNSET Ridge LOT # 165
 Facility Type: SFD-56x54-3BR New Expansion Repair
 Basement? Yes No Basement Fixtures? Yes No
 Type of Wastewater System** 25% Reduction Sys. (Initial) Wastewater Flow: 360 GPD
 (See note below, if applicable 290 LF of LPP (Repair))

Installation Requirements/Conditions

Septic Tank Size 1000 gallons Exact length of each trench 1x180 feet Trench Spacing: 9 Feet on Center
 Pump Tank Size _____ gallons Trenches shall be installed on contour at a Soil Cover: 6 inches
 Maximum Trench Depth of: 18'24" inches (Maximum soil cover shall not exceed 36" above the trench bottom)
 (Trench bottoms shall be level to +1/4" in all directions)
 Pump Requirements: _____ ft. TDH vs. _____ GPM Aggregate Depth: _____ inches below pipe
 _____ inches above pipe
 Conditions: _____ inches total

****If applicable:** *I understand the system type specified is different from the type specified on the application. I accept the specifications of this permit.*

Owner/Legal Representative Signature: _____ Date: _____

This Construction Authorization is subject to revocation if the site plan, plat, or the intended use changes. The Construction Authorization shall not be transferred when there is a change in ownership of the site. This Construction Authorization is subject to compliance with the provisions of the Laws and Rules for Sewage Treatment and Disposal and to the conditions of this permit.

Authorized State Agent: J. Lucas Date: 08-10-07 SEE ATTACHED SITE SKETCH
 Construction Authorization Expiration Date: 08-10-2012

HTE# 07-52018124

Permit # 24265

Harnett County Department of Public Health Site Sketch

ISSUED TO: Israel Lucas PROPERTY LOCATOR: 1141
SUBDIVISION: Sunset Ridge LOT # 165

Authorized State Agent: J. Lucas Date: 08-10-07
100'

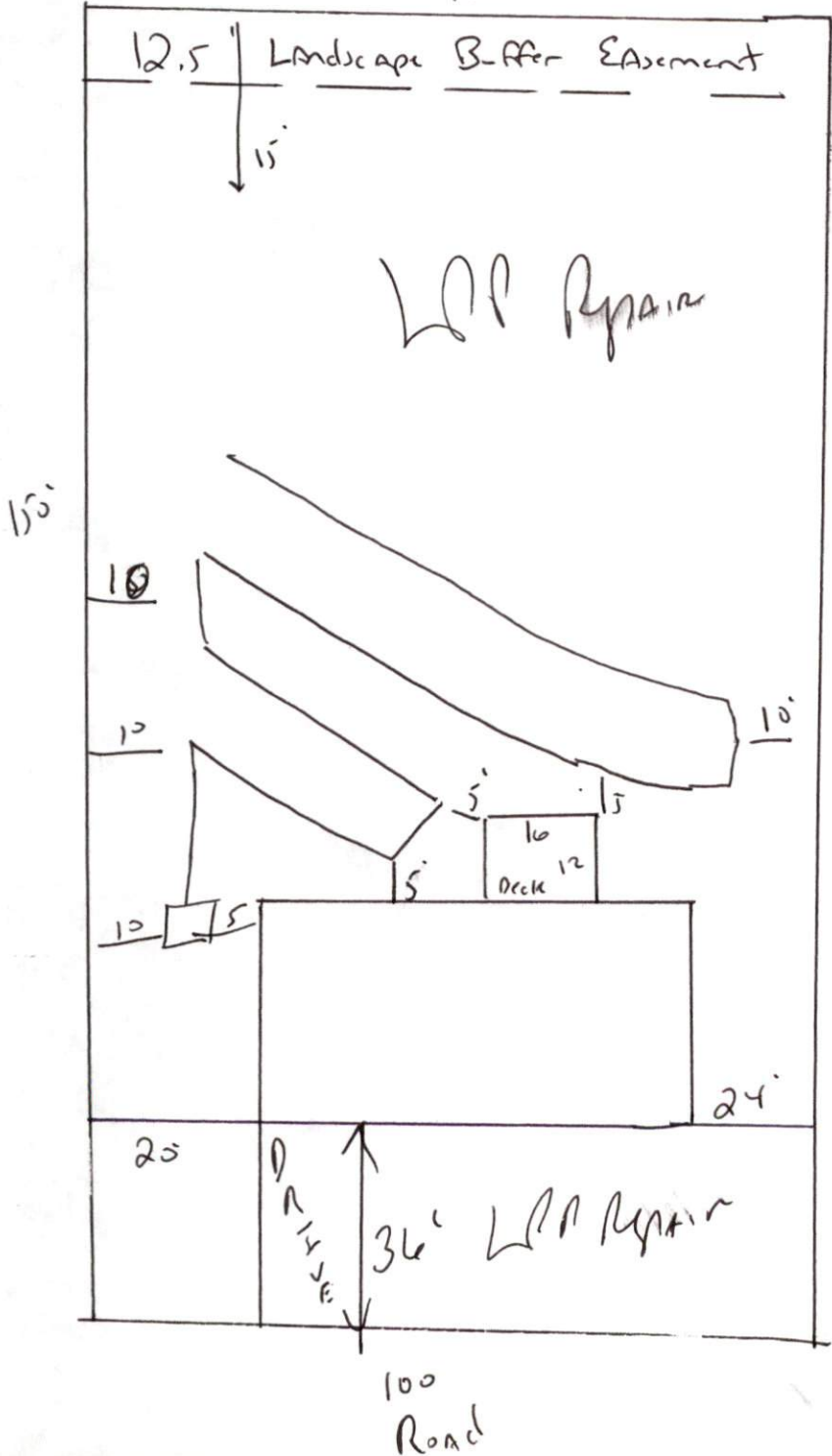

MAINTAIN ALL
Setbacks
STUDY Plumbing
shallow at ground
level or higher
where shown

Install 1x180 of
25% reduction system
at 18-24"

keep drain field
15' from Rear
Property Line