

Initial Application Date: 7/30/07

Application # 0750018130

lot 148

COUNTY OF HARNETT LAND USE APPLICATION

Central Permitting 108 E. Front Street, Lillington, NC 27546 Phone: (910) 893-7525 Fax: (910) 893-2793 www.harnett.org

LANDOWNER: Allied Investors Inc. Mailing Address: PO Box 53786

City: Fayetteville State: NC Zip: 28305 Home #: _____ Contact #: _____

APPLICANT*: Israel Lucas Mailing Address: 4432 Fox Run Rd

City: Sanford State: NC Zip: 27330 Home #: 776 1071 Contact #: 919-770-0902

*Please fill out applicant information if different than landowner

PROPERTY LOCATION: State Road #: _____ State Road Name: Northview Dr.

Parcel: 03958709 0020 23 PIN: 9586-96-8627-000

Zoning: RA20R Subdivision: Sunset Ridge Sec 3 Lot #: 148 Lot Size: 36

Flood Plain: NOX Panel: 9586 Watershed: N/A Deed Book/Page: OTB Plat Book/Page: 2002/1509

SPECIFIC DIRECTIONS TO THE PROPERTY FROM LILLINGTON: 27 W to Tingen Rd, Rt on Alpine, Left on Northview Dr

PROPOSED USE:

- SFD (Size 32 x 12) # Bedrooms 3 # Baths 2 Basement (w/wo bath) _____ Garage Yes Deck Yes Circle: Crawl Space Slab
- Modular: On frame Off frame (Size _____ x _____) # Bedrooms _____ # Baths _____ Garage _____ (site built? _____) Deck _____ (site built? _____)
- Multi-Family Dwelling No. Units _____ No. Bedrooms/Unit _____
- Manufactured Home: SW DW TW (Size _____ x _____) # Bedrooms _____ Garage _____ (site built? _____) Deck _____ (site built? _____)
- Business Sq. Ft. Retail Space _____ Type _____ # Employees: _____ Hours of Operation: _____
- Industry Sq. Ft. _____ Type _____ # Employees: _____ Hours of Operation: _____
- Church Seating Capacity _____ # Bathrooms _____ Kitchen _____
- Home Occupation (Size _____ x _____) # Rooms _____ Use _____ Hours of Operation: _____
- Accessory/Other (Size _____ x _____) Use _____
- Addition to Existing Building (Size _____ x _____) Use _____ Closets in addition()yes ()no

Water Supply: (X) County () Well (No. dwellings _____) () Other

Sewage Supply: (X) New Septic Tank (Must fill out New Tank Checklist) () Existing Septic Tank () County Sewer () Other

Property owner of this tract of land own land that contains a manufactured home w/in five hundred feet (500') of tract listed above? ()YES (X)NO

Structures on this tract of land: Single family dwellings 1 PROP Manufactured Homes _____ Other (specify) _____

Required Residential Property Line Setbacks: Comments: _____

	Minimum	Actual
Front	35	36
Rear	25	41
Side	10	24+24
Sidestreet/corner lot	20	/
Nearest Building on same lot	10	/

If permits are granted I agree to conform to all ordinances and the laws of the State of North Carolina regulating such work and the specifications of plans submitted. I hereby state that the foregoing statements are accurate and correct to the best of my knowledge. This permit is subject to revocation if false information is provided on this form.

Signature of Owner or Owner's Agent: Israel Lucas

Date: 7/30/07

This application expires 6 months from the initial date if no permits have been issued

A RECORDED SURVEY MAP, RECORDED DEED (OR OFFER TO PURCHASE) AND PLAT ARE REQUIRED WHEN APPLYING FOR LAND USE APPLICATION

Please use Blue or Black Ink ONLY

18130

1" = 25'

lot 148 Northview Dr
Sunset Ridge Sec 3
PIN 9586-96-8627.000

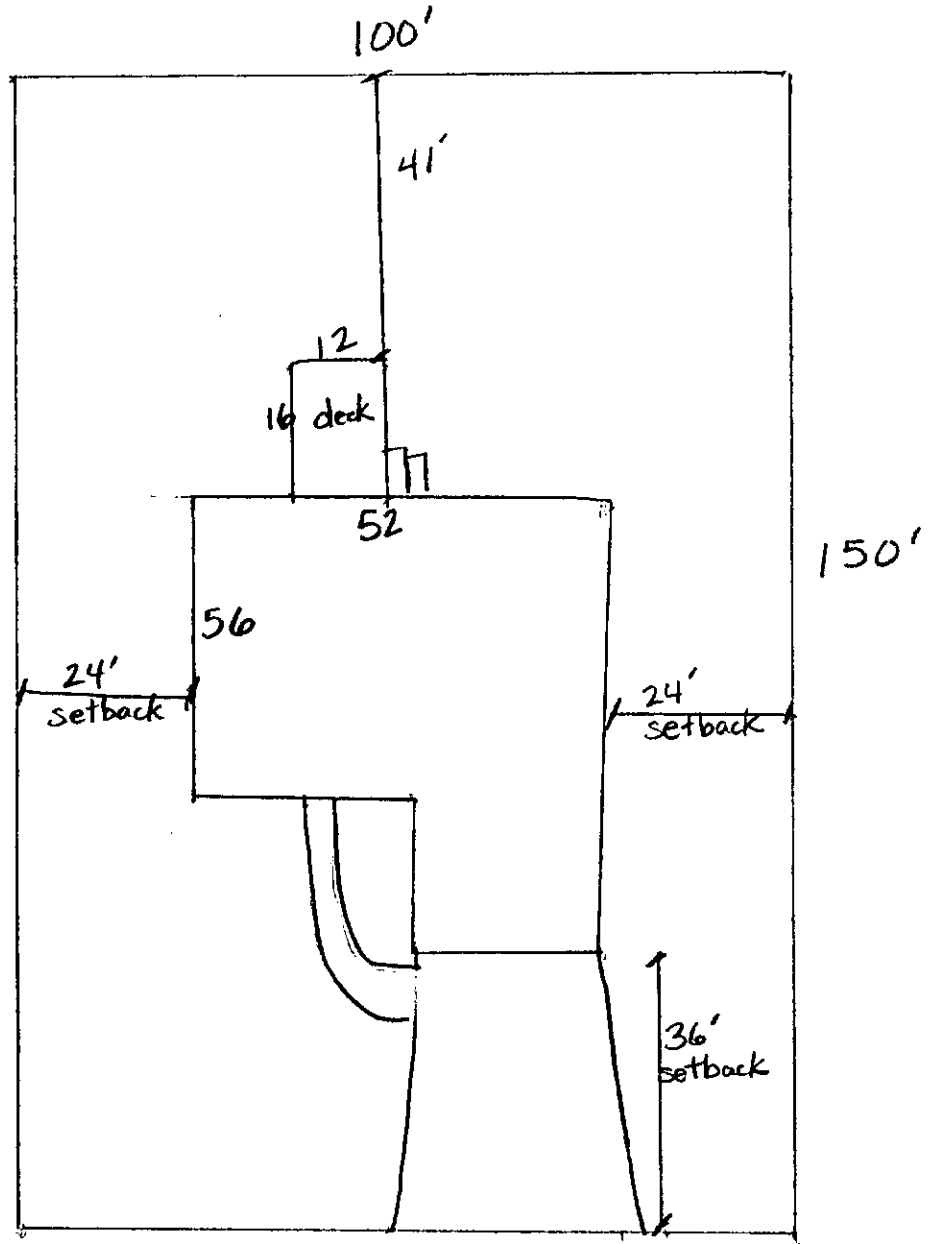

SITE PLAN APPROVAL

DISTRICT RAZOR USE SFD

#BEDROOMS 3

Opno 8/2/07
ZONING ADMINISTRATOR

Applicant Israel Lucas

OWNER NAME: Allied Investors

lot 148
APPLICATION #: 0750018130

This application to be filled out only when applying for a new septic system.

County Health Department Application for Improvement Permit and/or Authorization to Construct

IF THE INFORMATION IN THIS APPLICATION IS FALSIFIED, CHANGED, OR THE SITE IS ALTERED, THEN THE IMPROVEMENT PERMIT OR AUTHORIZATION TO CONSTRUCT SHALL BECOME INVALID. The permit is valid for either 60 months or without expiration depending upon documentation submitted. (complete site plan = 60 months; complete plat = without expiration)

DEVELOPMENT INFORMATION

- New single family residence
- Expansion of existing system
- Repair to malfunctioning sewage disposal system
- Non-residential type of structure

WATER SUPPLY

- New well
- Existing well
- Community well
- Public water
- Spring

Are there any existing wells, springs, or existing waterlines on this property?

yes no unknown

SEPTIC

If applying for authorization to construct please indicate desired system type(s): can be ranked in order of preference. must choose one.

- Accepted Innovative
- Alternative Other
- Conventional Any

The applicant shall notify the local health department upon submittal of this application if any of the following apply to the property in question. If the answer is "yes", applicant must attach supporting documentation.

- YES NO Does the site contain any Jurisdictional Wetlands?
- YES NO Does the site contain any existing Wastewater Systems?
- YES NO Is any wastewater going to be generated on the site other than domestic sewage?
- YES NO Is the site subject to approval by any other Public Agency?
- YES NO Are there any easements or Right of Ways on this property?
- YES NO Does the site contain any existing water, cable, phone or underground electric lines?

If yes please call No Cuts at 800-632-4949 to locate the lines. This is a free service.

I Have Read This Application And Certify That The Information Provided Herein Is True, Complete And Correct. Authorized County And State Officials Are Granted Right Of Entry To Conduct Necessary Inspections To Determine Compliance With Applicable Laws And Rules. I Understand That I Am Solely Responsible For The Proper Identification And Labeling Of All Property Lines And Corners And Making The Site Accessible So That A Complete Site Evaluation Can Be Performed.

Israel Lucas

7/30/07

PROPERTY OWNERS OR OWNERS LEGAL REPRESENTATIVE SIGNATURE (REQUIRED)

DATE

0750018130 10+148

Application Number:

0750018131 10+151

Harnett County Central Permitting Department

PO Box 65, Lillington, NC 27546
910-893-7525

0750018132 10+163

0750018133 10+164

0750018134 10+165

Environmental Health New Septic Systems Test
Environmental Health Code **800**

- Place "property flags" on each corner iron of lot. All property lines must be clearly flagged approximately every 50 feet between corners.
- Place "house corner flags" at each corner of where the house/manufactured home will sit. Use additional flagging to outline driveways, garages, decks, out buildings, swimming pools, etc.
- Place flags at locations as developed on site plan by Customer Service Technician and you.
- Place Environmental Health "orange" card in location that is easily viewed from road.
- If property is thickly wooded, Environmental Health requires that you clean out the undergrowth to allow the soil evaluation to be performed. Inspectors should be able to walk freely around site. *No grading of property should be done.*
- Call No Cuts to locate utility lines prior to scheduling inspection. 800-632-4949 (This is a free service)
- After preparing proposed site call the voice permitting system at 910-893-7525 and give code **800** for Environmental Health confirmation. **Please note confirmation number given at end of recording for proof of request.**
- Use Click2Gov or IVR to hear results. Once approved, proceed to Central Permitting for permits.

Environmental Health Existing Tank Inspections
Environmental Health Code **800**

- Place Environmental Health "orange" card in location that is easily viewed from road. Follow above instructions for placing flags on property.
- Prepare for inspection by removing soil over door as diagram indicates. Loosen trap door cover. (Unless inspection is for a septic tank in a mobile home park)
- After preparing trapdoor call the voice permitting system at 910-893-7525 and give code **800** for Environmental Health confirmation. **Please note confirmation number given at end of recording for proof of request.**
- Use Click2Gov or IVR to hear results. Once approved, proceed to Central Permitting for remaining permits.

Health and Sanitation Inspections

- After submitting plans for food and lodging to Central Permitting, please allow approximately 7-10 working days for plan status. Use Click2Gov or IVR to hear results.
- Once **all** plans are approved, proceed to Central Permitting for remaining permits.

Fire Marshal Inspections

- After submitting plans for Fire Marshal review to Central Permitting, please allow approximately 7-10 working days for approval. Use Click2Gov or IVR to hear results. Once **all** plans are approved, proceed to Central Permitting for permits.
- Fire Marshal's letter must be placed on job site until work is completed.

Public Utilities

- Place stake with "orange" tape/name thirty feet (30) from the center of the road at the location you wish to have water tap installed.
- Allow four to six weeks after application for water/sewer taps. Call Utilities at 893-7575 for technical assistance.

Building Inspections

- After submitting plans for Building Inspections, please allow approximately 3 working days for review. Use Click2Gov or IVR to hear results. Once **all** plans are approved, proceed to Central Permitting for permits.
- For new housing/set up permits must meet E 911 / Addressing guidelines prior to scheduling final inspection.
- Use Click2Gov or IVR to hear results.

E911 Addressing

Addressing Confirmation Code **814**

- Address numbers shall be mounted on the house, 3 inches high (5" for commercial).
- Numbers must be a contrasting color from house, must be clearly visible night and day at entrance of driveway if home is 100 ft or more from road, or if mailbox is on opposite side of road.
- Once you purchase permits and footing inspection has been approved call the voice permitting system at 910-893-7525 and give code **814** for address confirmation. This must be called in even if you have contacted E911 for verbal confirmation. Check Click2Gov for results and address.

• Inspection results can be viewed online at <http://www.harnett.org/services-213.asp> then select **Click2Gov**

Applicant/Owner Signature Israel Lunn Date 7/30/07

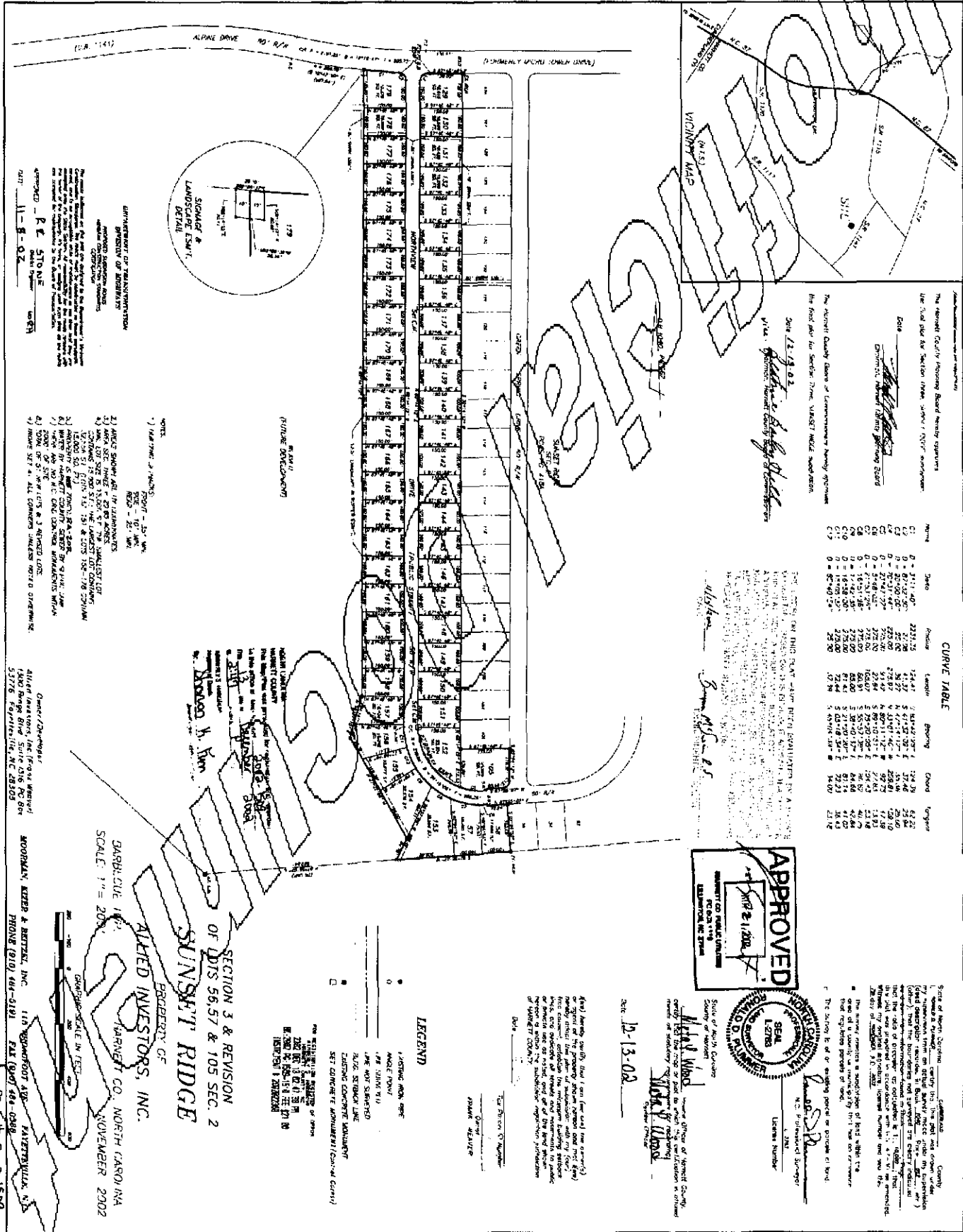

The applicant hereby requests that the Board review and approve the final plan for Section 3, Dpts 56.57 & 105 Sec. 2.

DATE: 12-13-02
 BY: *[Signature]*
 TITLE: *[Title]*

CURVE TABLE

Station	Length	Beginning	Ending	Radius
0+00	124.47	0+00	0+124.47	2233.25
0+124.47	41.27	0+124.47	0+165.74	2233.25
0+165.74	278.87	0+165.74	0+444.61	2233.25
0+444.61	311.47	0+444.61	0+756.08	2233.25
0+756.08	165.07	0+756.08	0+921.15	2233.25
0+921.15	80.35	0+921.15	0+1001.50	2233.25
0+1001.50	165.07	0+1001.50	0+1166.57	2233.25
0+1166.57	80.35	0+1166.57	0+1246.92	2233.25
0+1246.92	165.07	0+1246.92	0+1412.00	2233.25
0+1412.00	80.35	0+1412.00	0+1492.35	2233.25
0+1492.35	165.07	0+1492.35	0+1657.42	2233.25
0+1657.42	80.35	0+1657.42	0+1737.77	2233.25
0+1737.77	165.07	0+1737.77	0+1902.85	2233.25
0+1902.85	80.35	0+1902.85	0+1983.20	2233.25
0+1983.20	165.07	0+1983.20	0+2148.27	2233.25
0+2148.27	80.35	0+2148.27	0+2228.62	2233.25
0+2228.62	165.07	0+2228.62	0+2393.70	2233.25
0+2393.70	80.35	0+2393.70	0+2474.05	2233.25
0+2474.05	165.07	0+2474.05	0+2639.12	2233.25
0+2639.12	80.35	0+2639.12	0+2719.47	2233.25
0+2719.47	165.07	0+2719.47	0+2884.55	2233.25
0+2884.55	80.35	0+2884.55	0+2964.90	2233.25
0+2964.90	165.07	0+2964.90	0+3129.97	2233.25
0+3129.97	80.35	0+3129.97	0+3210.32	2233.25
0+3210.32	165.07	0+3210.32	0+3375.40	2233.25
0+3375.40	80.35	0+3375.40	0+3455.75	2233.25
0+3455.75	165.07	0+3455.75	0+3620.82	2233.25
0+3620.82	80.35	0+3620.82	0+3701.17	2233.25
0+3701.17	165.07	0+3701.17	0+3866.25	2233.25
0+3866.25	80.35	0+3866.25	0+3946.60	2233.25
0+3946.60	165.07	0+3946.60	0+4111.67	2233.25
0+4111.67	80.35	0+4111.67	0+4192.02	2233.25
0+4192.02	165.07	0+4192.02	0+4357.10	2233.25
0+4357.10	80.35	0+4357.10	0+4437.45	2233.25
0+4437.45	165.07	0+4437.45	0+4602.52	2233.25
0+4602.52	80.35	0+4602.52	0+4682.87	2233.25
0+4682.87	165.07	0+4682.87	0+4847.95	2233.25
0+4847.95	80.35	0+4847.95	0+4928.30	2233.25
0+4928.30	165.07	0+4928.30	0+5093.37	2233.25
0+5093.37	80.35	0+5093.37	0+5173.72	2233.25
0+5173.72	165.07	0+5173.72	0+5338.80	2233.25
0+5338.80	80.35	0+5338.80	0+5419.15	2233.25
0+5419.15	165.07	0+5419.15	0+5584.22	2233.25
0+5584.22	80.35	0+5584.22	0+5664.57	2233.25
0+5664.57	165.07	0+5664.57	0+5829.65	2233.25
0+5829.65	80.35	0+5829.65	0+5910.00	2233.25
0+5910.00	165.07	0+5910.00	0+6075.07	2233.25
0+6075.07	80.35	0+6075.07	0+6155.42	2233.25
0+6155.42	165.07	0+6155.42	0+6320.50	2233.25
0+6320.50	80.35	0+6320.50	0+6400.85	2233.25
0+6400.85	165.07	0+6400.85	0+6565.92	2233.25
0+6565.92	80.35	0+6565.92	0+6646.27	2233.25
0+6646.27	165.07	0+6646.27	0+6811.35	2233.25
0+6811.35	80.35	0+6811.35	0+6891.70	2233.25
0+6891.70	165.07	0+6891.70	0+7056.77	2233.25
0+7056.77	80.35	0+7056.77	0+7137.12	2233.25
0+7137.12	165.07	0+7137.12	0+7302.20	2233.25
0+7302.20	80.35	0+7302.20	0+7382.55	2233.25
0+7382.55	165.07	0+7382.55	0+7547.62	2233.25
0+7547.62	80.35	0+7547.62	0+7628.00	2233.25
0+7628.00	165.07	0+7628.00	0+7793.07	2233.25
0+7793.07	80.35	0+7793.07	0+7873.42	2233.25
0+7873.42	165.07	0+7873.42	0+8038.50	2233.25
0+8038.50	80.35	0+8038.50	0+8118.85	2233.25
0+8118.85	165.07	0+8118.85	0+8283.92	2233.25
0+8283.92	80.35	0+8283.92	0+8364.27	2233.25
0+8364.27	165.07	0+8364.27	0+8529.35	2233.25
0+8529.35	80.35	0+8529.35	0+8609.70	2233.25
0+8609.70	165.07	0+8609.70	0+8774.77	2233.25
0+8774.77	80.35	0+8774.77	0+8855.12	2233.25
0+8855.12	165.07	0+8855.12	0+9020.20	2233.25
0+9020.20	80.35	0+9020.20	0+9100.55	2233.25
0+9100.55	165.07	0+9100.55	0+9265.62	2233.25
0+9265.62	80.35	0+9265.62	0+9346.00	2233.25
0+9346.00	165.07	0+9346.00	0+9511.07	2233.25
0+9511.07	80.35	0+9511.07	0+9591.42	2233.25
0+9591.42	165.07	0+9591.42	0+9756.50	2233.25
0+9756.50	80.35	0+9756.50	0+9836.85	2233.25
0+9836.85	165.07	0+9836.85	0+10001.92	2233.25
0+10001.92	80.35	0+10001.92	0+10082.27	2233.25

APPROVED
 DATE: 12-13-02
 BY: *[Signature]*

SEAL
 L. J. WOOD
 L. J. WOOD
 L. J. WOOD
 L. J. WOOD

LEGEND

- 1. EXISTING ROAD, OPEN
- 2. EXISTING ROAD, CLOSED
- 3. NEW ROAD
- 4. EXISTING CONCRETE DRIVEWAY
- 5. NEW CONCRETE DRIVEWAY
- 6. EXISTING SIDEWALK
- 7. NEW SIDEWALK
- 8. EXISTING UTILITY
- 9. NEW UTILITY
- 10. EXISTING FENCE
- 11. NEW FENCE
- 12. EXISTING SIGN
- 13. NEW SIGN
- 14. EXISTING LIGHT
- 15. NEW LIGHT
- 16. EXISTING TREE
- 17. NEW TREE
- 18. EXISTING LANDSCAPE
- 19. NEW LANDSCAPE
- 20. EXISTING LOT
- 21. NEW LOT
- 22. EXISTING LOT AREA
- 23. NEW LOT AREA
- 24. EXISTING LOT AREA
- 25. NEW LOT AREA
- 26. EXISTING LOT AREA
- 27. NEW LOT AREA
- 28. EXISTING LOT AREA
- 29. NEW LOT AREA
- 30. EXISTING LOT AREA
- 31. NEW LOT AREA
- 32. EXISTING LOT AREA
- 33. NEW LOT AREA
- 34. EXISTING LOT AREA
- 35. NEW LOT AREA
- 36. EXISTING LOT AREA
- 37. NEW LOT AREA
- 38. EXISTING LOT AREA
- 39. NEW LOT AREA
- 40. EXISTING LOT AREA
- 41. NEW LOT AREA
- 42. EXISTING LOT AREA
- 43. NEW LOT AREA
- 44. EXISTING LOT AREA
- 45. NEW LOT AREA
- 46. EXISTING LOT AREA
- 47. NEW LOT AREA
- 48. EXISTING LOT AREA
- 49. NEW LOT AREA
- 50. EXISTING LOT AREA
- 51. NEW LOT AREA
- 52. EXISTING LOT AREA
- 53. NEW LOT AREA
- 54. EXISTING LOT AREA
- 55. NEW LOT AREA
- 56. EXISTING LOT AREA
- 57. NEW LOT AREA
- 58. EXISTING LOT AREA
- 59. NEW LOT AREA
- 60. EXISTING LOT AREA
- 61. NEW LOT AREA
- 62. EXISTING LOT AREA
- 63. NEW LOT AREA
- 64. EXISTING LOT AREA
- 65. NEW LOT AREA
- 66. EXISTING LOT AREA
- 67. NEW LOT AREA
- 68. EXISTING LOT AREA
- 69. NEW LOT AREA
- 70. EXISTING LOT AREA
- 71. NEW LOT AREA
- 72. EXISTING LOT AREA
- 73. NEW LOT AREA
- 74. EXISTING LOT AREA
- 75. NEW LOT AREA
- 76. EXISTING LOT AREA
- 77. NEW LOT AREA
- 78. EXISTING LOT AREA
- 79. NEW LOT AREA
- 80. EXISTING LOT AREA
- 81. NEW LOT AREA
- 82. EXISTING LOT AREA
- 83. NEW LOT AREA
- 84. EXISTING LOT AREA
- 85. NEW LOT AREA
- 86. EXISTING LOT AREA
- 87. NEW LOT AREA
- 88. EXISTING LOT AREA
- 89. NEW LOT AREA
- 90. EXISTING LOT AREA
- 91. NEW LOT AREA
- 92. EXISTING LOT AREA
- 93. NEW LOT AREA
- 94. EXISTING LOT AREA
- 95. NEW LOT AREA
- 96. EXISTING LOT AREA
- 97. NEW LOT AREA
- 98. EXISTING LOT AREA
- 99. NEW LOT AREA
- 100. EXISTING LOT AREA
- 101. NEW LOT AREA
- 102. EXISTING LOT AREA
- 103. NEW LOT AREA
- 104. EXISTING LOT AREA
- 105. NEW LOT AREA

SECTION 3 & REVISION
 OF DPTS 56.57 & 105 SEC. 2
SUNSET RIDGE
 PROPERTY OF
ALFRED INVESTORS, INC.
 YARBERT CO., NORTH CAROLINA
 NOVEMBER 2002

SCALE: 1" = 20'

MOORHEAD KEENE & BERTZEL, INC. 118 BROADWAY AVE. FAYETTEVILLE, NC
 PHONE (910) 661-0181 FAX (910) 661-0588

Map # 2002-1504

UNIVERSITY OF NORTH CAROLINA
 DEPARTMENT OF TRANSPORTATION
 DIVISION OF TRANSPORTATION
 OFFICE OF TRANSPORTATION
 100 SOUTH MAIN STREET
 RALEIGH, NC 27601

APPROVED - R & S 510 N.E.
 DATE: 11-8-02

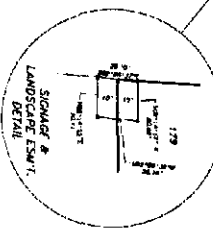

- NOTES**
- 1) SEE MAP 2002-1504 FOR GENERAL INFORMATION.
 - 2) ALL DISTANCES ARE IN FEET AND DECIMALS THEREOF.
 - 3) ALL DISTANCES ARE TO BE MEASURED TO THE CENTERLINE OF THE ROAD.
 - 4) ALL DISTANCES ARE TO BE MEASURED TO THE CENTERLINE OF THE ROAD.
 - 5) ALL DISTANCES ARE TO BE MEASURED TO THE CENTERLINE OF THE ROAD.
 - 6) ALL DISTANCES ARE TO BE MEASURED TO THE CENTERLINE OF THE ROAD.
 - 7) ALL DISTANCES ARE TO BE MEASURED TO THE CENTERLINE OF THE ROAD.
 - 8) ALL DISTANCES ARE TO BE MEASURED TO THE CENTERLINE OF THE ROAD.
 - 9) ALL DISTANCES ARE TO BE MEASURED TO THE CENTERLINE OF THE ROAD.
 - 10) ALL DISTANCES ARE TO BE MEASURED TO THE CENTERLINE OF THE ROAD.



Click on the Map to:

ZoomIn ZoomOut Recenter Map Identify: Tax Parcels
Zoom Factor: 2X Radius Search (feet) 0

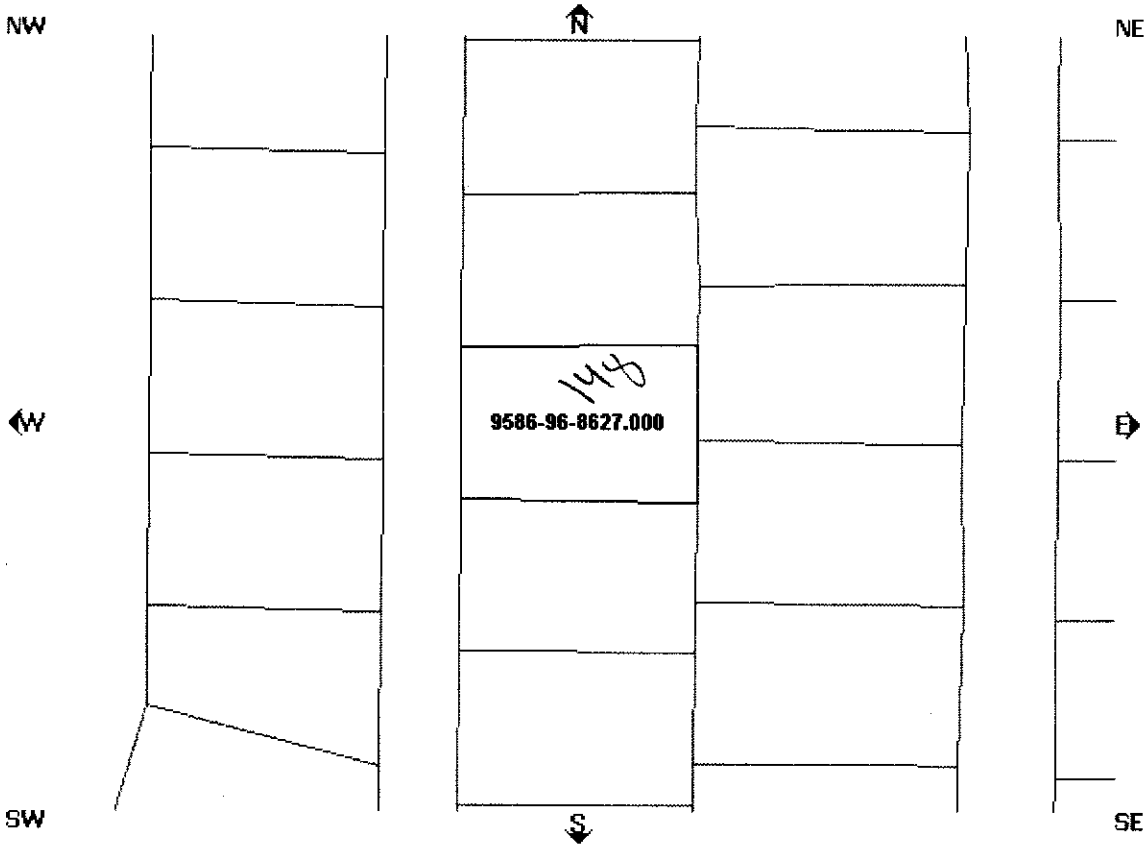

Parcel Data

Find Adjoining Parcels

Map Layers
Draw Layers
Draw selected layers:
Boundary
Townships
Tax Parcels
Aerial Photography 2005
Aerial Photography 2002
Fire Tax Districts
Fire Insurance Districts
Rescue Districts
Zoning
Government
Commissioners Districts
Voting Precincts
Census Tracts
School District
Infrastructure
Major Roads
Roads
Physical
Soils
Multi Symbol
Rivers
Watershed
Flood Zones
Multi Symbol
Draw Layers
MAP Currency

This map is prepared for the inventory of real property found within this jurisdiction, and is compiled from recorded deeds, plats, and other public records and data. Users of this map are hereby notified that the aforementioned public primary information sources should be consulted for verification of the information contained on this map. The Harnett County, mapping, and software companies assume no legal responsibility for the information contained on this map or in this website.

Data Effective Date: 7/23/2007 10:30:04 AM

Current Date: 7/23/2007 Time: 10:35:12 AM

Table with 2 columns containing parcel details: Account Number, Owner Name, Address, City, State Zip, Commissioners District, Voting Precinct, Census Tract, Determine Flood Zone(s), In Town, Fire Ins. District, School District, Zoning Code, PIN, REID, Parcel ID, Legal 1, Legal 2, Property Address, Assessed Acres, Calculated Acres, Deed Book/Page, Deed Date, Sale Price, Revenue Stamps, Year Built, Heated Sq. Ft., Building Value, Land Value, Assessed Value.

OFFER TO PURCHASE AND CONTRACT - VACANT LOT/LAND

NOTE: This contract is intended for unimproved real property that Buyer will purchase only for personal use and will not subdivide. It should not be used to sell subdivided property that has not been platted, properly approved and recorded with the register of deeds as of the date of the contract. If Seller is Buyer's builder and the sale involves the construction of a new single family dwelling prior to closing, use the standard Offer to Purchase and Contract (Form 2-T) with the New Construction Addendum (Form 2A3-T).

Israel Lucas Construction

as Buyer, hereby offers to purchase and
Allied Development Inc.

as Seller, upon acceptance of said offer, agrees to sell and convey, all of that plot, piece or parcel of land described below (hereafter referred to as the "Property"), upon the following terms and conditions:

1. REAL PROPERTY: Located in the City of Sanford, County of Harnett, State of North Carolina, being known as and more particularly described as: Street Address Northview Dr. Sunset Ridge Zip 27332
Subdivision Name Sunset Ridge
Plat Reference: Lot 165, 164, 151, 163, 148, Block or Section 3 as shown on Plat Book or Slide 2002 at Page(s) 1509 (Property acquired by Seller in Deed Book 1145 at Page 347).

All A portion of the property in Deed Reference: Book 1145 Page No. 347, Harnett County
NOTE: Prior to signing this Offer to Purchase and Contract - Vacant Lot/Land, Buyer is advised to review Restrictive Covenants, if any, which may limit the use of the Property, and to read the Declaration of Restrictive Covenants, By-Laws, Articles of Incorporation, Rules and Regulations, and other governing documents of the owners' association and/or the subdivision, if applicable.

2. PURCHASE PRICE: The purchase price is \$ 112,500 and shall be paid as follows:

- (a) \$ 5000.00, EARNEST MONEY DEPOSIT with this offer by cash personal check bank check certified check other: n/a to be deposited and held in escrow by Barfield and Radford Law Office ("Escrow Agent"); until the sale is closed, at which time it will be credited to Buyer, or until this contract is otherwise terminated. In the event: (1) this offer is not accepted; or (2) any of the conditions hereto are not satisfied, then all earnest monies shall be refunded to Buyer. In the event of breach of this contract by Seller, all earnest monies shall be refunded to Buyer upon Buyer's request, but such return shall not affect any other remedies available to Buyer for such breach. In the event of breach of this contract by Buyer, then all earnest monies shall be forfeited to Seller upon Seller's request, but such forfeiture shall not affect any other remedies available to Seller for such breach.
NOTE: In the event of a dispute between Seller and Buyer over the return or forfeiture of earnest money held in escrow by a broker, the broker is required by state law to retain said earnest money in the broker's trust or escrow account until a written release from the parties consenting to its disposition has been obtained or until disbursement is ordered by a court of competent jurisdiction.
- (b) \$ n/a, ADDITIONAL EARNEST MONEY DEPOSIT to be paid to Escrow Agent no later than n/a, TIME BEING OF THE ESSENCE WITH REGARD TO SAID DATE.
- (c) \$ n/a, OPTION FEE in accordance with paragraph 11, Alternative 2, to be paid to Seller on the Effective Date as set forth in paragraph 19. (NOTE: If Alternative 2 applies, then do not insert \$0, N/A, or leave blank).
- (d) \$ n/a, BY ASSUMPTION of the unpaid principal balance and all obligations of Seller on the existing loan(s) secured by a deed of trust on the Property in accordance with the attached Loan Assumption Addendum.
- (e) \$ n/a, BY SELLER FINANCING in accordance with the attached Seller Financing Addendum.
- (f) \$ n/a, BALANCE of the purchase price in cash at Closing.

3. CONDITIONS: (State N/A in each blank that is not a condition to this contract.)

(a) Buyer must be able to obtain a Conventional Other: n/a loan at a Fixed Rate Adjustable Rate in the principal amount of n/a for a term of _____



1" = 25'

104 148 Northrow Dr.
Sunset Ridge Sec 3
PIN 9586-96-8627.000

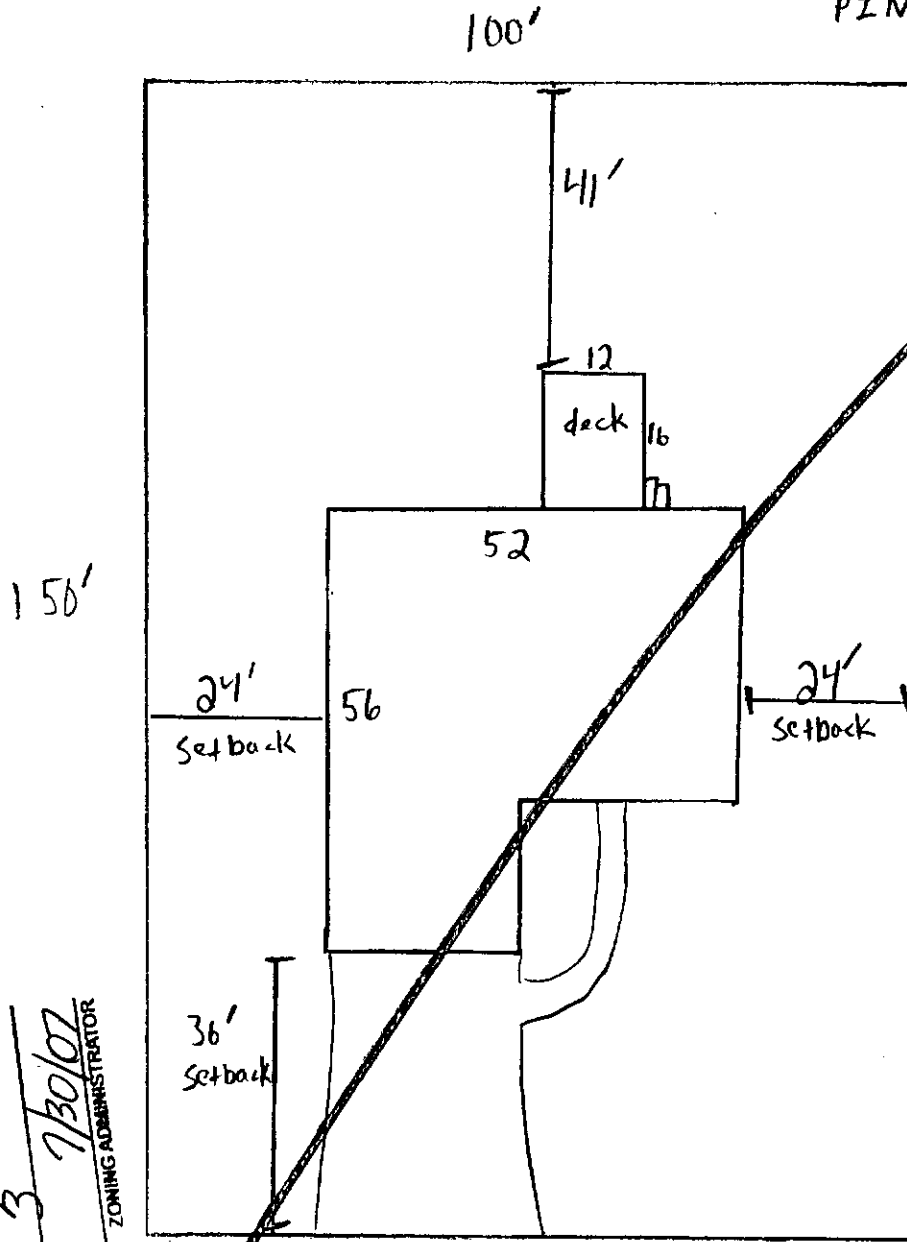

*Should have been
revised, not
scheduled yet so
didn't charge fee*

SITE PLAN APPROVAL
 DISTRICT RAZOR USE SFD
3
 BEDROOMS 3
 ZONING ADMINISTRATOR 7/30/07

18130

1" = 25'

lot 148 Northview Dr
Sunset Ridge Sec 3
PIN 9586-96-8627.000

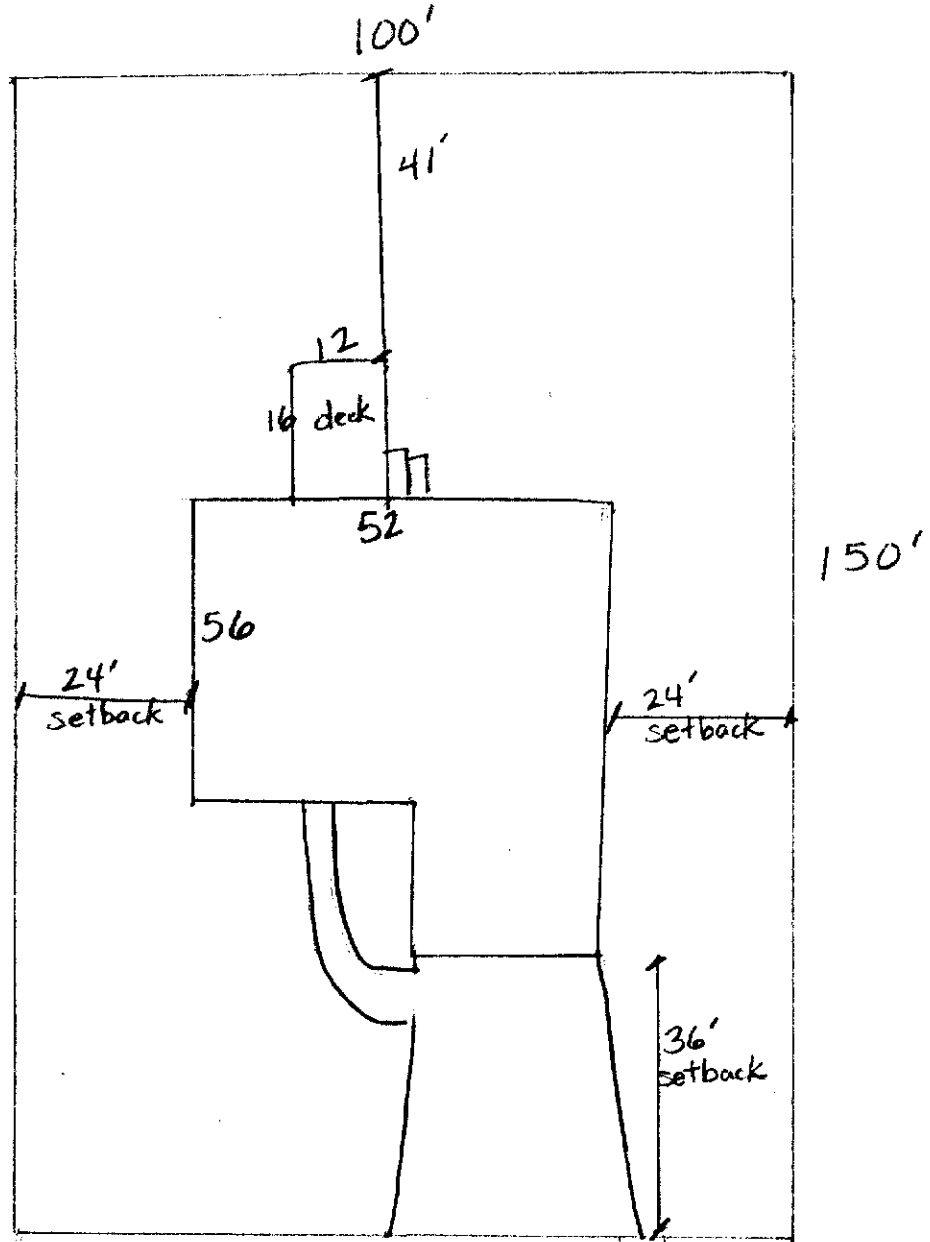

SITE PLAN APPROVAL
 DISTRICT RAZOR USE SFD
 #BEDROOMS 3
Qno 8/2/07
 ZONING ADMINISTRATOR