

Initial Application Date: 2-21-07 ^{8/8107}

Application # 07-50016966R

Central Permitting 108 E. Front Street, Lillington, NC 27546 Phone: (910) 893-7525 Fax: (910) 893-2793 www.harnett.org

LANDOWNER: SHC Holdings, Inc. Mailing Address: 4466 Stoncill Rd

City: Angier State: NC Zip: 27501 Home #: 919-639-2073 Contact #: 919-639-2073

APPLICANT: Same as above Mailing Address: _____

City: _____ State: _____ Zip: _____ Home #: _____ Contact #: _____

PROPERTY LOCATION: State Road #: 1505 State Road Name: Silas Hayes Rd

Parcel: 0701091 0023 38 PIN: 0691-5825344.000

Zoning: RA-30 Subdivision: Hunters Point Lot #: 39 Lot Size: 0.461

Flood Plain: X Panel: N/A Watershed: N/A Deed Book/Page: 2317.744 Plat Book/Page: 2006/1128

SPECIFIC DIRECTIONS TO THE PROPERTY FROM LILLINGTON: Hwy 27 to Coats, left on Hwy 55 towards Angier, right on Silas Hayes Rd, Subdivision on right

PROPOSED USE:

- SFD (Size 40 x 100) # Bedrooms 3 # Baths 2.5 Basement (w/wo bath) _____ Garage Deck Circle: Crawl Space Slab
- Modular: On frame Off frame (Size x) # Bedrooms _____ # Baths _____ Garage _____ (site built?) Deck _____ (site built?)
- Multi-Family Dwelling No. Units _____ No. Bedrooms/Unit _____
- Manufactured Home: SW DW TW (Size x) # Bedrooms _____ Garage _____ (site built?) Deck _____ (site built?)
- Business Sq. Ft. Retail Space _____ Type _____ # Employees: _____ Hours of Operation: _____
- Industry Sq. Ft. _____ Type _____ # Employees: _____ Hours of Operation: _____
- Church Seating Capacity _____ # Bathrooms _____ Kitchen _____
- Home Occupation (Size x) # Rooms _____ Use _____ Hours of Operation: _____
- Accessory/Other (Size x) Use _____
- Addition to Existing Building (Size x) Use _____ Closets in addition (yes no)

Water Supply: County Well (No. dwellings 13) Other _____

Sewage Supply: New Septic Tank (Need to fill out New Tank Checklist) Existing Septic Tank County Sewer Other _____

Property owner of this tract of land own land that contains a manufactured home w/in five hundred feet (500') of tract listed above? YES NO

Structures on this tract of land: Single family dwellings _____ Manufactured Homes _____ Other (specify) _____

Required Residential Property Line Setbacks: per code

Side	Minimum	Actual	Comments
Front	35	35/35'	Site soil report per EH, customer moved home \$65'
Rear	25	120 25'	
Side	10	30	
Corner/Sidestreet	20	---	
Nearest Building on same lot	10	---	

If permits are granted I agree to conform to all ordinances and the laws of the State of North Carolina regulating such work and the specifications of plans submitted. I hereby state that the foregoing statements are accurate and correct to the best of my knowledge. This permit is subject to revocation if false information is provided on this form.

Signature of Owner or Owner's Agent [Signature]

Date 2-16-07

This application expires 6 months from the initial date if no permits have been issued
A RECORDED SURVEY MAP, RECORDED DEED (OR OFFER TO PURCHASE) AND PLAT ARE REQUIRED WHEN APPLYING FOR LAND USE APPLICATION

Please use Blue or Black Ink ONLY

Lot 39 Hunters Point
168 High Standard Lane
07-50016966
Revised
8/6/07

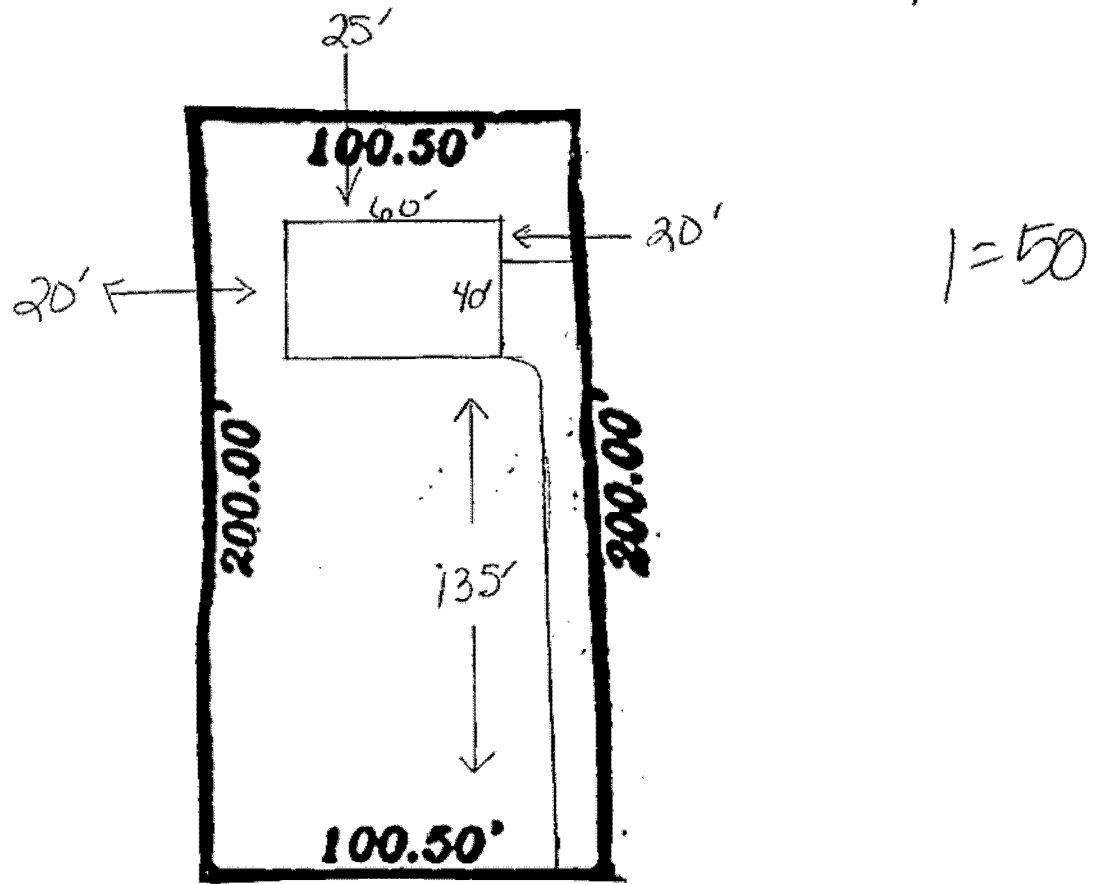

High Standard LN

SITE PLAN APPROVAL

DISTRICT RA30 USE SFD

#BEDROOMS 3

QAO 8/8/07
ZONING ADMINISTRATOR

B 8-6-07
Kenda [Signature]

Lot 39 Hunters Point
168 High Standard Ln.

1=50

SITE PLAN APPROVAL

DISTRICT RA30 USE SFD

#BEDROOMS 3

2.22.07 D. Johnson
ZONING ADMINISTRATOR

High Standard Ln.

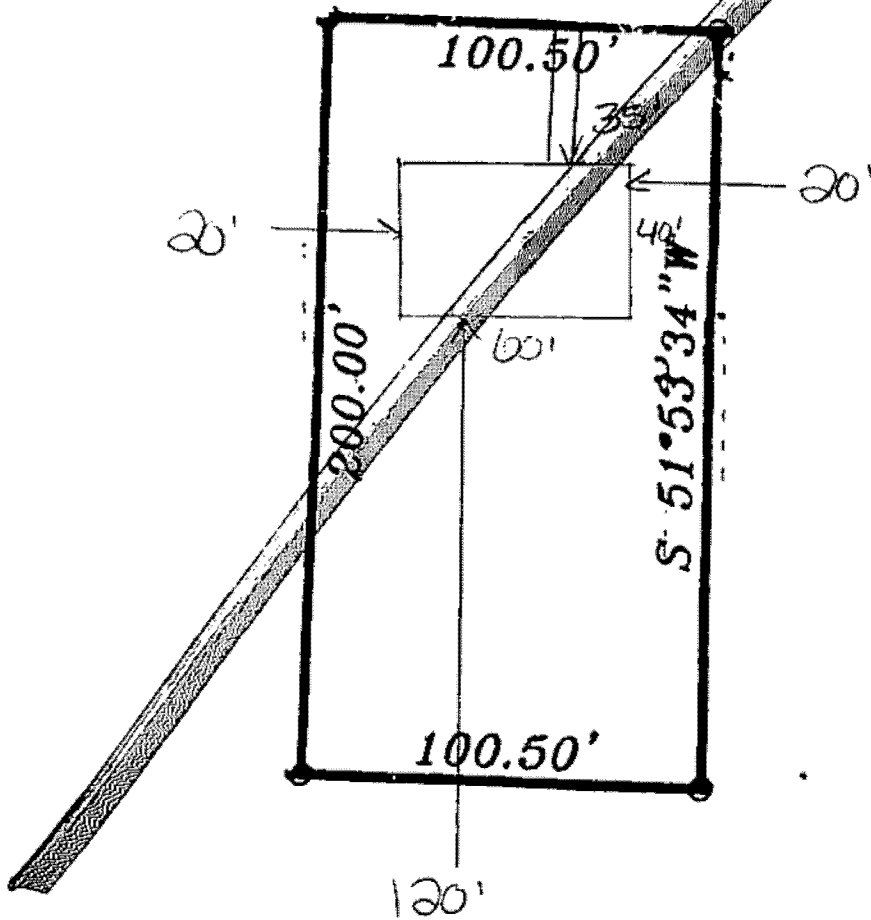

Aug 03 07 01:53p

michael eaker

9108224540

p. 7

Southeastern Soil & Environmental Associates, Inc.

P.O. Box 8321
Fayetteville, NC 28311
Phone/Fax (910) 822-4540
Email meaker3851@aol.com

MEMO (8/3/2007)

To: Gina/Freddie

From: Mike Eaker *ME*

Re: Hunter's Point Lots 37, 38, 39 & 40

Following are layouts for 37 & 38 which have been approved by the health department (please notice the revised house location & size on lot 37). You should submit a new plot plan for lot 37

Lots 39 & 40 are much more difficult. I have attached a map showing 2 options:

1- where you can get 2 lots with each house setback about 135 feet back (pretreatment systems required on repairs) or;

2- recombination of the 2 lots with a normal setback.

Please advise as to how to proceed!

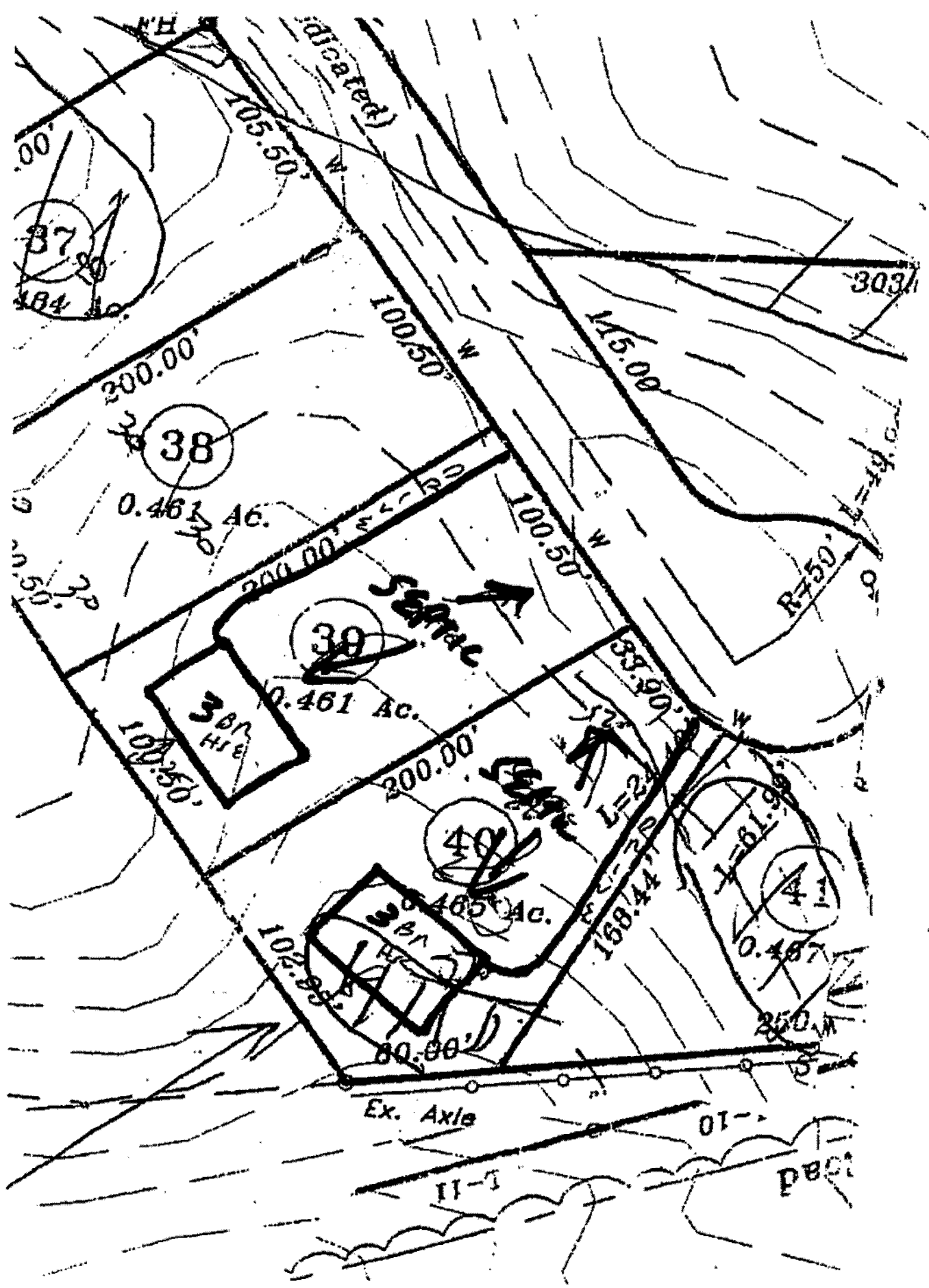

Option 1

Aug 03 07 01:52P michael baker 9108224540 p.2

OWNER NAME: SHC Holdings, Inc.

APPLICATION #: 0750016966

This application to be filled out only when applying for a new septic system.

County Health Department Application for Improvement Permit and/or Authorization to Construct

IF THE INFORMATION IN THIS APPLICATION IS FALSIFIED, CHANGED, OR THE SITE IS ALTERED, THEN THE IMPROVEMENT PERMIT OR AUTHORIZATION TO CONSTRUCT SHALL BECOME INVALID. The permit is valid for either 60 months or without expiration depending upon documentation submitted. (complete site plan = 60 months; complete plat = without expiration)

DEVELOPMENT INFORMATION

- New single family residence
- Expansion of existing system
- Repair to malfunctioning sewage disposal system
- Non-residential type of structure

WATER SUPPLY

- New well
- Existing well
- Community well
- Public water
- Spring

Are there any existing wells, springs, or existing waterlines on this property?

yes no unknown

SEPTIC

If applying for authorization to construct please indicate desired system type(s): can be ranked in order of preference, must choose one.

- Accepted Innovative
- Alternative Other
- Conventional Any

The applicant shall notify the local health department upon submittal of this application if any of the following apply to the property in question. If the answer is "yes", applicant must attach supporting documentation.

- YES NO Does the site contain any Jurisdictional Wetlands?
- YES NO Does the site contain any existing Wastewater Systems?
- YES NO Is any wastewater going to be generated on the site other than domestic sewage?
- YES NO Is the site subject to approval by any other Public Agency?
- YES NO Are there any easements or Right of Ways on this property?
- YES NO Does the site contain any existing water, cable, phone or underground electric lines?

If yes please call No Cuts at 800-632-4949 to locate the lines. This is a free service.

I Have Read This Application And Certify That The Information Provided Herein Is True, Complete And Correct. Authorized County And State Officials Are Granted Right Of Entry To Conduct Necessary Inspections To Determine Compliance With Applicable Laws And Rules. I Understand That I Am Solely Responsible For The Proper Identification And Labeling Of All Property Lines And Corners And Making The Site Accessible So That A Complete Site Evaluation Can Be Performed.

PROPERTY OWNERS OR OWNERS LEGAL REPRESENTATIVE SIGNATURE (REQUIRED)

2-11-07
DATE

UNRECORDED



HARNETT COUNTY TAX ID#

07-0691-0023

12-15-06 BY VHD

FOR REGISTRATION REGISTER OF DEEDS
HARNETT COUNTY, NC
2006 DEC 15 11:55:57 AM
BK:2317 PG:744-747 FEE:\$28.00

INSTRUMENT # 2006023454

Excise Tax NONE

Recording Time, Book & Page

HEIR- DESCRIPTION 52 +/- acrs. off NC SR 1365

Hold For Adams & Howell, P.A

Parcel Identification No : 070691 0023

Prepared By Currie Tee Howell, Attorney at Law
NO TITLE SEARCH OR TAX ADVICE

NORTH CAROLINA GENERAL WARRANTY DEED

This WARRANTY DEED is made this 15th day of December, 2006 by and between, **FREDDIE L. STANCL** and wife, **KATHY H. STANCL**; **T. GERALD HOWELL**, and wife, **PHYLLIS S. HOWELL**, and **NELSON DURANE CURRIN** and wife, **DONNA K. CURRIN**, whose address is 466 Stancel Rd, Angier, NC 27501 party(ies) of the first part, hereinafter referred to as the Grantor(s), and **SHC HOLDINGS, INC. (A NORTH CAROLINA CORPORATION)**, party(ies) of the second part, whose address is 466 Stancel Rd, Angier, NC 27501, hereinafter referred to as the Grantee(s).

WITNESSETH

WHEREAS Grantor(s) for and in consideration of the Sum of Ten Dollars (\$10.00) and other good and valuable consideration, receipt of which is hereby acknowledged, have given, granted, bargained, sold and conveyed, and by these presents do hereby give, grant, bargain, sell and convey unto the Grantee in fee simple Said property being all of that certain piece, parcel or tract of land situated, lying and being in Grove Township, Harnett County, North Carolina, and more particularly described as follows:

BEING all of Tract A (totaling 18.223 acres) and Tract B (totaling 34.821 acres) as shown on map recorded in Map Number 2005, Page 799, Harnett County Registry.

Subject to all easements, rights-of-way, covenants and other restrictions as shown on the public record or as would be disclosed by an accurate survey and inspection of the land.

See Deed Book 2138 Page 361, Estate Pils 05E-496 Harnett County Clerk of Court (same estate filed at 81-E-1251, Wake County Clerk of Court) and Deed Book 232 Page 461.

TO HAVE AND TO HOLD the above described lands and premises, together with all appurtenances thereunto belonging, or in anywise appertaining, unto the Grantee in fee simple, their heirs, successors and assigns forever, but subject always, however, to the limitations set out above

AND the said Grantors, parties of the first part, covenant to and with said Grantee, parties of the second part, their heirs, successors, administrators and assigns that they are lawfully seized in fee simple of said lands and premises, and have full right and power to convey the same to the Grantee in fee simple (but subject, however, to the limitations set out above) and that said lands and premises are free from any and all encumbrances, except as set forth above, and that

UNRECORDED

01-50016927, 16944, 16950, 16951, 16952, 16953, 16954, 16955,
 16956, 16957, 16958, 16959, 16960, 16961, 16962, 16963, 16964,
 16965, 16966, 16967, 16968,
 Application Number: _____

Harnett County Central Permitting Department
 PO Box 65, Lillington, NC 27546
 910-893-7525

Environmental Health New Septic Systems Test
Environmental Health Code 800

- Place "property flags" on each corner iron of lot. All property lines must be clearly flagged approximately every 50 feet between corners.
- Place "house corner flags" at each corner of where the house/manufactured home will sit. Use additional flagging to outline driveways, garages, decks, out buildings, swimming pools, etc.
- Place flags at locations as developed on site plan by Customer Service Technician and you.
- Place Environmental Health "orange" card in location that is easily viewed from road.
- If property is thickly wooded, Environmental Health requires that you clean out the undergrowth to allow the soil evaluation to be performed. Inspectors should be able to walk freely around site. *No grading of property should be done.*
- Call No Cuts to locate utility lines prior to scheduling inspection. 800-632-4949 (This is a free service)
- After preparing proposed site call the voice permitting system at 910-893-7525 and give code **800** for Environmental Health confirmation. Please note confirmation number given at end of recording for proof of request.
- Use Click2Gov or IVR to hear results. Once approved, proceed to Central Permitting for permits.

Environmental Health Existing Tank Inspections
Environmental Health Code 800

- Place Environmental Health "orange" card in location that is easily viewed from road. Follow above instructions for placing flags on property.
- Prepare for inspection by removing soil over door as diagram indicates. Loosen trap door cover. (Unless inspection is for a septic tank in a mobile home park)
- After preparing trapdoor call the voice permitting system at 910-893-7525 and give code **800** for Environmental Health confirmation. Please note confirmation number given at end of recording for proof of request.
- Use Click2Gov or IVR to hear results. Once approved, proceed to Central Permitting for remaining permits.

Health and Sanitation Inspections

- After submitting plans for food and lodging to Central Permitting, please allow approximately 7-10 working days for plan status. Use Click2Gov or IVR to hear results.
- Once all plans are approved, proceed to Central Permitting for remaining permits.

Fire Marshal Inspections

- After submitting plans for Fire Marshal review to Central Permitting, please allow approximately 7-10 working days for approval. Use Click2Gov or IVR to hear results. Once all plans are approved, proceed to Central Permitting for permits.
- Fire Marshal's letter must be placed on job site until work is completed.

Public Utilities

- Place stake with "orange" tape/name thirty feet (30) from the center of the road at the location you wish to have water tap installed.
- Allow four to six weeks after application for water/sewer taps. Call Utilities at 893-7575 for technical assistance.

Building Inspections

- After submitting plans for Building Inspections, please allow approximately 3 working days for review. Use Click2Gov or IVR to hear results. Once all plans are approved, proceed to Central Permitting for permits.
- For new housing/set up permits must meet E 911 / Addressing guidelines prior to scheduling final inspection.
- Use Click2Gov or IVR to hear results.

E911 Addressing

- Addressing Confirmation Code 814**
- Address numbers shall be mounted on the house, 3 inches high (5" for commercial).
 - Numbers must be a contrasting color from house, must be clearly visible night and day at entrance of driveway if home is 100 ft or more from road, or if mailbox is on opposite side of road.
 - Once you purchase permits and footing inspection has been approved call the voice permitting system at 910-893-7525 and give code **814** for address confirmation. This must be called in even if you have contacted E911 for verbal confirmation. Check Click2Gov for results and address.

• Inspection results can be viewed online at <http://www.harnett.org/services-213.asp> then select Click2Gov

Applicant/Owner Signature  Date 2-22-07