

HTE# 07-50016912

Harnett County Department of Public Health 23684

Thomas Properties

Improvement Permit

A building permit cannot be issued with only an Improvement Permit

ISSUED TO: Tom Properties PROPERTY LOCATION: 1272
 SUBDIVISION Darlington Hills LOT # 6
 NEW REPAIR EXPANSION
 Type of Structure: SFD - 45x60 JBR
 Proposed Wastewater System Type: GRAVEL
 Projected Daily Flow: 360 GPD
 Number of bedrooms: 3 Number of Occupants: 6 max
 Basement Yes No
 Pump Required: Yes No May be required based on final location and elevations of facilities
 Type of Water Supply: Community Public Well Distance from well _____ feet Permit valid for: Five years
 Permit conditions: STUB out Plumbing shallow where shown maintain No expiration
All setbacks meet on-site for final layout

Authorized State Agent: Joe Wiles Date: 2-28-07 SEE ATTACHED SITE SKETCH
 The issuance of this permit by the Health Department in no way guarantees the issuance of other permits. The permit holder is responsible for checking with appropriate governing bodies in meeting their requirements. This site is subject to revocation if the site plan, plat, or the intended use changes. The Improvement Permit shall not be affected by a change in ownership of the site. This permit is subject to compliance with the provisions of the Laws and Rules for Sewage Treatment and Disposal and to conditions of this permit.

Construction Authorization

(Required for Building Permit)

The construction and installation requirements of Rules .1950, .1952, .1954, .1955, .1956, .1957, .1958, and .1959 are incorporated by references into this permit and shall be met. Systems shall be installed in accordance with the attached system layout.

ISSUED TO: Tom Properties PROPERTY LOCATION: 1272
 SUBDIVISION Darlington Hills LOT # 6
 Facility Type: SFD - 45x60 New Expansion Repair
 Basement? Yes No Basement Fixtures? Yes No
 Type of Wastewater System** GRAVEL (Initial) Wastewater Flow: 360 GPD
 (See note below, if applicable) 400 LF of LEP (Repair)

Installation Requirements/Conditions

Septic Tank Size 1000 gallons Exact length of each trench 1 x 400 feet Trench Spacing: 9 Feet on Center
 Pump Tank Size _____ gallons Trenches shall be installed on contour at a Soil Cover: 6 inches
 Maximum Trench Depth of: 18 inches (Maximum soil cover shall not exceed 36" above the trench bottom)
 (Trench bottoms shall be level to +/- 1/4" in all directions)
 Pump Requirements: _____ ft. TDH vs. _____ GPM Aggregate Depth: 6 inches below pipe
 Conditions: _____ 2 inches above pipe
 _____ 12 inches total

**If applicable: I understand the system type specified is different from the type specified on the application. I accept the specifications of this permit.

Owner/Legal Representative Signature: _____ Date: _____

This Construction Authorization is subject to revocation if the site plan, plat, or the intended use changes. The Construction Authorization shall not be transferred when there is a change in ownership of the site. This Construction Authorization is subject to compliance with the provisions of the Laws and Rules for Sewage Treatment and Disposal and to the conditions of this permit.

Authorized State Agent: Joe Wiles Date: 2-28-07 SEE ATTACHED SITE SKETCH
 Construction Authorization Expiration Date: 2-28-2012

HTE# 07-500/6912

Permit # 23684

Harnett County Department of Public Health

Site Sketch

Thomas Properties

ISSUED TO: Te7 Properties

PROPERTY LOCATOR: 1272

SUBDIVISION: Darlington Hills

LOT # 6

Authorized State Agent: J. L. ...

Date: 2.28-07

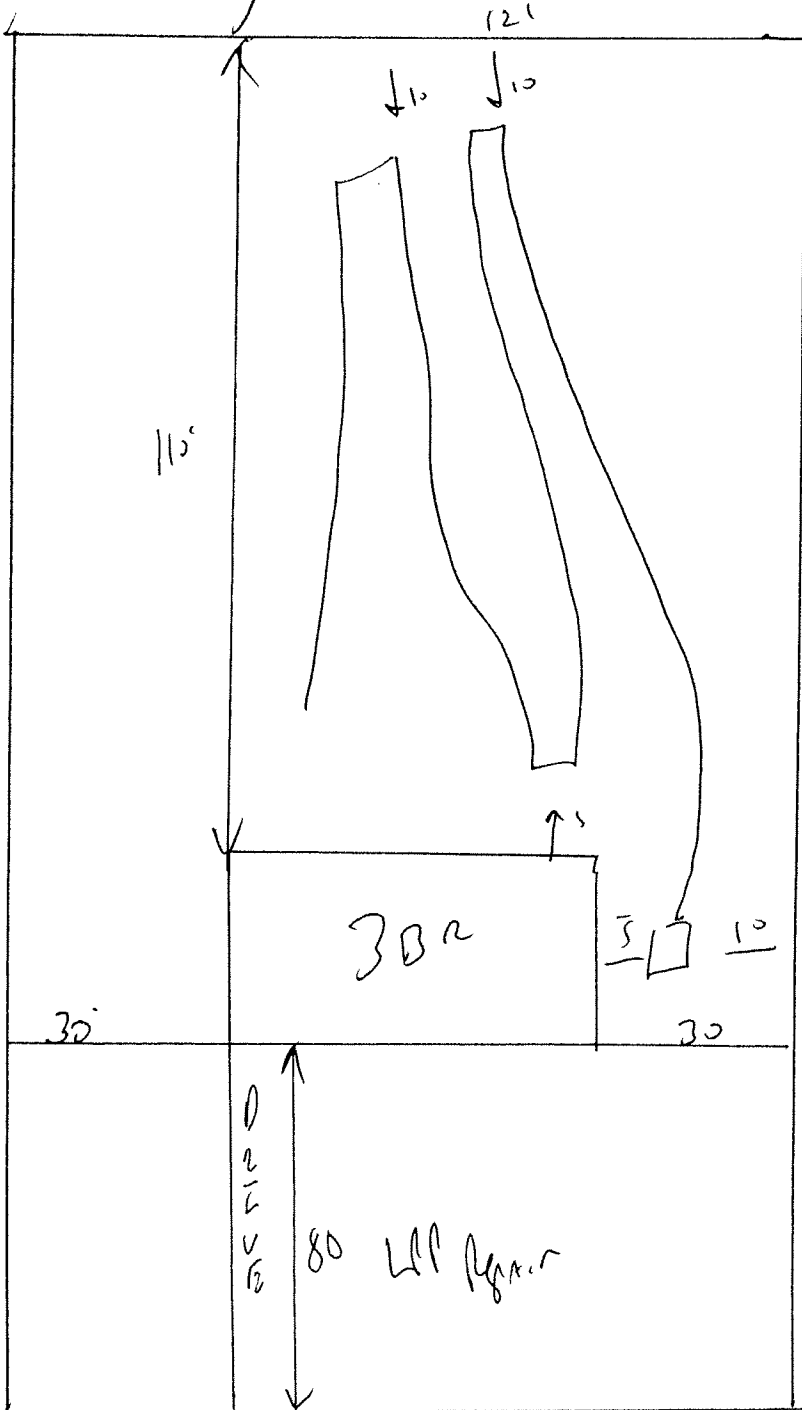

STUB out Plumbing
Shallow where shown

MAINTAIN ALL
Setbacks

Meet on site.

Install 1x400
of gravel AT 18"

249

249

Rd 121 setback