

County of Harnett  
Building Inspections Department  
Planning Services

**Certificate of Compliance: x Occupancy: x**

Certificate issued pursuant to the requirements of North Carolina General Statute 153A-363 and Harnett County Zoning Ordinances. This certifies at the time of issuance, this structure was in compliance with the various ordinances of the County of Harnett and the North Carolina State Building Codes. For the following:

Use Classification: R-3

**Permit Numbers**

Name: Bill Clark Homes

Building: 07-50016751

Address: 16 Mossburg Ct.

Electrical: \_\_\_\_\_

Insulation: \_\_\_\_\_

Plumbing: \_\_\_\_\_

Mechanical: \_\_\_\_\_

MFG Home: \_\_\_\_\_

Date: 4-13-12

Building Official: T. Michael Reine

-----  
ADDRESS . : 16 MOSSBURG CT  
CONTRACTOR : BILL CLARK HOMES LLC  
OWNER . . : BILL CLARK HOMES  
PARCEL . . : 01-0525-01- -0095- -26-  
APPL NUMBER: 07-50016751 CP NEW RESIDENTIAL (SFD)  
-----

SUBDIV: GATEWEST 53 LOTS  
PHONE : (252) 355-5805  
PHONE : (910) 263-9026

TYP/SQ	REQUESTED COMPLETED	INSP RESULT	DESCRIPTION RESULTS/COMMENTS
R431 01	4/03/12 4/03/12	MR DP	FOUR TRADE FINAL >2500 VRU #: 002210627 VOICE MESSAGE LEFT T/S: 04/03/2012 11:50 AM MREARIC ----- house locked, no numbers
R431 02	4/11/12 4/11/12	MR DA	FOUR TRADE FINAL >2500 TIME: 17:00 VRU #: 002213809 T/S: 04/10/2012 10:19 AM DJOHNSON ----- T/S: 04/11/2012 01:44 PM MREARIC ----- outside ac's not wired water heater not wired breaker sizes on ac's wrong install handrails and weather-stripping clean out insulation from air handler pans
R431 03	4/13/12 <u>4-13-12</u>	TI <u>AP-MR</u>	FOUR TRADE FINAL >2500 VRU #: 002214847

----- COMMENTS AND NOTES -----

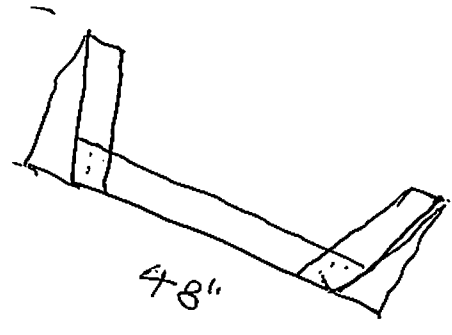

4x12  
50x20

#2.25	Frames
1.80	Flywood
.40	Paint+epoxy
1.50	Motor
3.00	2 People
<hr/>	
\$9.95	
100	