

HTE# 06-5-15431

# IMPROVEMENT PERMIT 23121

Be it ordained by the Harnett County Board of Health as follows: Section III, Item B. "No person shall begin construction of any building at which a septic tank system is to be used for disposal of sewage without first obtaining a written permit from the Harnett County Health Department."

Name: (owner) Sherwill DUNCAN New Installation  Septic Tank  Repair   
 Property Location: SR# 1540 Montague RD Nitrification Line  Expansion   
 Subdivision FRANCES DUNCAN Lot # 2  
 Tax ID# \_\_\_\_\_ Quadrant # \_\_\_\_\_  
 Number of Bedrooms Proposed: 3 BM 360 GPD Lot Size: 20+ Acs

Basement with Plumbing:  Garage:   
 Water Supply:  Well  Public  Community  
 Distance From Well: 100' ft.

**Following is the minimum specifications for sewage disposal system on above captioned property. Subject to final approval.**

Type of system:  Conventional  Other 25% Reduction System

Size of tank: Septic Tank: 1000 gallons Pump Tank: \_\_\_\_\_ gallons

Subsurface	No. of	exact length	width of	depth of
Drainage Field	ditches	of each ditch	ditches	ditches
	<u>3</u>	<u>100</u>	<u>3</u>	<u>24</u>
	ft.	ft.	ft.	in.

French Drain Required: - Linear feet

Date: 8-8-06  
PERMIT EXPIRES 5 YEARS FROM ABOVE DATE

**This permit is subject to revocation if site plans or intended use change.**

Signed: James E. Markantons  
Environmental Health Specialist

\* ANY CHANGES TO LOT  
VOIDS PERMIT

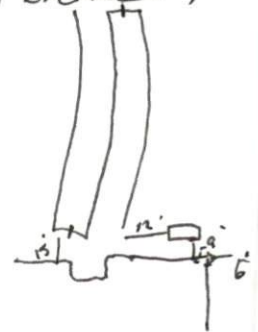
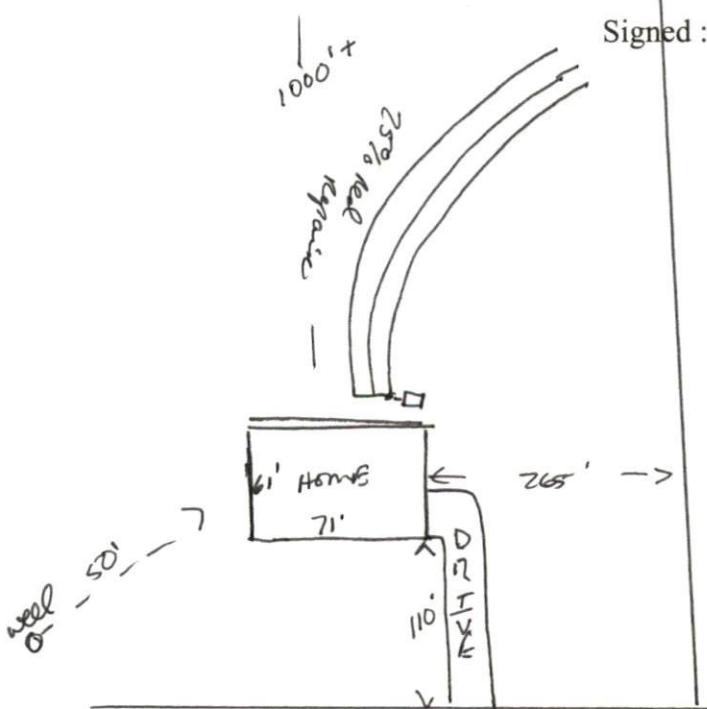

SR 1540 MONTAGUE RD

#06-5-15431

# HARNETT COUNTY DEPARTMENT OF PUBLIC HEALTH AUTHORIZATION TO CONSTRUCT

Authorization is hereby given to construct a wastewater system to the specifications described by Harnett County Department of Public Health, Improvement Permit # 23121. This authorization shall be valid for a period not to exceed five (5) years from the date of issuance. ***This authorization will be invalid if ownership, site plans, or intended use change.***

Name Sherrill Duncan Telephone # 919-635-2205

Address 1315 Montague RD Argyle N.C. 27501

Property Location SR# 1540 Road Name Montague

Subdivision F.D Lot # 2 # Bedrooms Proposed 3 BR 360 GPD Lot Size 20 ac +

### TYPE OF SYSTEM

- New Installation     Repair     Septic Tank     Nitrification Lines
- Conventional     Other 25% Reduction Syst
- Basement     With Plumbing     Without Plumbing

Water Supply:  Well     Public Water Supply Minimum Well Setback: \_\_\_\_\_ Ft.

Septic Tank 1000 gal    Pump Chamber \_\_\_\_\_ gal

### NITRIFICATION FIELD SPECIFICATIONS

Number of fields 2 # of lines per field 3 Length of lines 100 Ft.

Width of ditches 3 ft. Depth of ditches 24" inches

French Drain: Linear feet required — Depth of gravel —

No wastewater system shall be covered or placed into use by any person until an inspection by the Harnett County Health Department has determined that the system has been installed according to the conditions of the Improvement Permit and that a valid Operations Permit has been issued.

James E. Manbrake  
Signature of Authorized Agent for Harnett County

8-8-06  
Date