

HTE# 06-5-15211

IMPROVEMENT PERMIT 23000

Be it ordained by the Harnett County Board of Health as follows: Section III, Item B. "No person shall begin construction of any building at which a septic tank system is to be used for disposal of sewage without first obtaining a written permit from the Harnett County Health Department."

Name: (owner) ALEX & LEIGH ADAMS New Installation Septic Tank Repair
Property Location: SR# 1535 MITCHELL RD Nitrification Line Expansion
Subdivision CURTIS & JUDITH ADAMS Lot # 1
Tax ID# _____ Quadrant # _____
Number of Bedrooms Proposed: 4 (480 gpd) Lot Size: 2.54 AC

Basement with Plumbing: Garage:
Water Supply: Well Public Community
Distance From Well: 100 ft.

Following is the minimum specifications for sewage disposal system on above captioned property. Subject to final approval.

Type of system: Conventional Other _____

Size of tank: Septic Tank: 1000 gallons Pump Tank: _____ gallons

Subsurface No. of exact length width of depth of
Drainage Field ditches 3 of each ditch 160 ft. ditches 3 ft. ditches 24 in.

French Drain Required: _____ Linear feet

Date: 7/6/06
PERMIT EXPIRES 5 YEARS FROM ABOVE DATE

This permit is subject to revocation if site plans or intended use change.

Signed: _____ RS (OLIVER TOLKSOOF)
Environmental Health Specialist

- * MAINTAIN ALL SETBACKS
- * SYSTEM FLAGGED
- * SYSTEM LOCATION & TYPE REQUESTED BY APPLICANT
- * CALL WITH ANY QUESTIONS PRIOR TO INSTALLATION

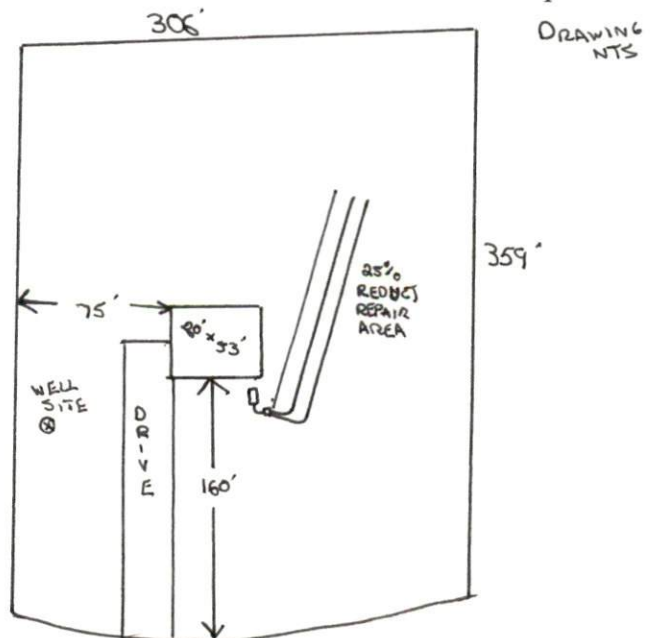

HARNETT COUNTY DEPARTMENT OF PUBLIC HEALTH
AUTHORIZATION TO CONSTRUCT

Authorization is hereby given to construct a wastewater system to the specifications described by Harnett County Department of Public Health, Improvement Permit # 23006. This authorization shall be valid for a period not to exceed five (5) years from the date of issuance. *This authorization will be invalid if ownership, site plans, or intended use change.*

ALEX & LEIGH ADAMS Name 719-639-6884 Telephone #

6357 NC 210N ANGIER NC 27501 Address

1535 Property Location SR# MITCHELL RD Road Name

CURTIS & JUDITH ADAMS 1 4 (480 sq) 2.54 ac
Subdivision Lot # # Bedrooms Proposed Lot Size

TYPE OF SYSTEM

New Installation [] Repair Septic Tank Nitrification Lines
 Conventional [] Other _____

[] Basement [] With Plumbing [] Without Plumbing

Water Supply: Well [] Public Water Supply Minimum Well Setback: 100 Ft.

Septic Tank 1000 gal Pump Chamber _____ gal

NITRIFICATION FIELD SPECIFICATIONS

Number of fields 1 # of lines per field 3 Length of lines 160 Ft.

Width of ditches 3 ft. Depth of ditches 24 inches

French Drain: Linear feet required _____ Depth of gravel _____

No wastewater system shall be covered or placed into use by any person until an inspection by the Harnett County Health Department has determined that the system has been installed according to the conditions of the Improvement Permit and that a valid Operations Permit has been issued.

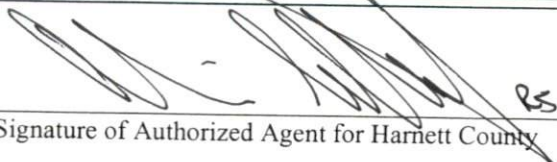
Signature of Authorized Agent for Harnett County

7/6/06
Date