



June 5, 2006

Danny Norris  
P O Box 727  
Dunn, NC 28335

**Re: Status of Improvement Permit Application #06-5-14925  
Lot # 165 Yorkshire Plantation**

Dear Mr. Norris,

On June 2, 2006, an Environmental Health Specialist from the Harnett County Health Department attempted to evaluate your property for the purpose of issuing an Improvement Permit. This individual was unable to evaluate your property for one or more of the following reasons.

- 1. Property lines/corners not marked or labeled
- 2. House corners not marked or labeled
- 3. Directions not clear to property
- 4. Property needs brush or vegetation removed
- 5. Backhoe pits required
- 6. Other – **Must move house as shown on attached sheet. Please submit new plot plan to Central Permitting, as a revision, and reconfirm through the automated phone system.**

When you have completed this, please call 910-893-7527 to confirm that the items mentioned have been corrected, we will then reschedule your property for evaluation.

Sincerely,

Joe West, R. S.  
Environmental Health Specialist  
Harnett County Department of Public Health

JW/ss  
Copy: Central Permitting

06-500.14925  
Lot 165  
Yorkshire Plantation

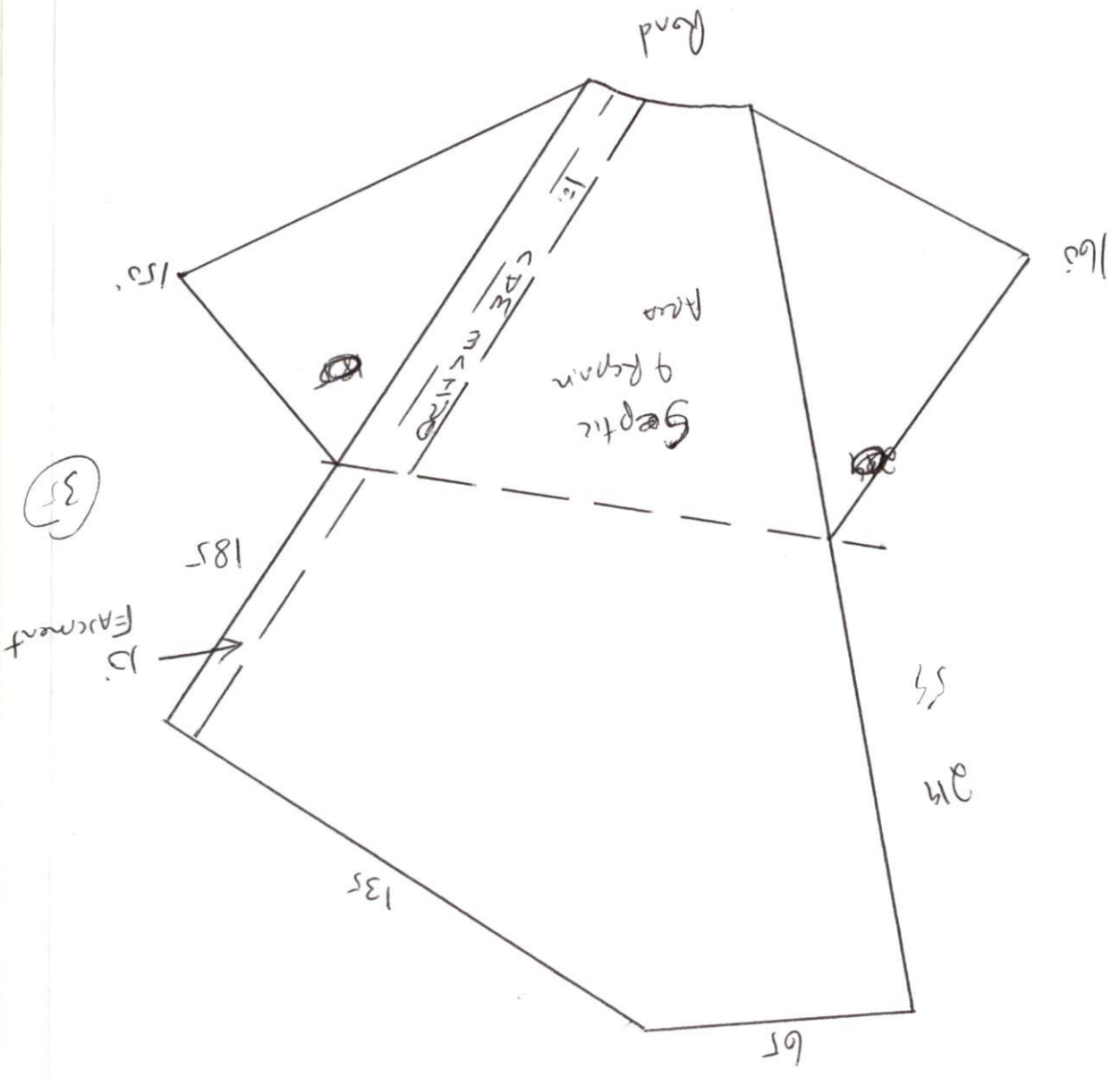

Mult Move how Back, Beyond shown set Backs  
Driveway must be along Property Line with Easement Along it  
Have to Be a Max of 10' Wide