

ADDRESS : 320 COBBLESTONE DR SUBDIV: STONE CROSS
CONTRACTOR : CHARNETZKY CUSTOM HOMES LLC PHONE : (252) 478-4045
OWNER : STONECROSS LLC PHONE :
PARCEL : 01-0535-14- -0100- -15-
APPL NUMBER: 06-50014024 CP NEW RESIDENTIAL (SFD)
DIRECTIONS : STONECROSS LOT 1. 210S TOWARDS SPRING
LAKE RIGHT ON RAY RD RIGHT ON OVERHILLS
TURN LEFT INTO STONECROSS ON STONECROSS
DRIVE RIGHT ON COBBLESTONE LOT ON LEFT.
#40R -A.DRIGGERS

STRUCTURE: 000 000 56X65 3BR SFD BASEMENT W/ GARAGE & DECK
FLOOD ZONE : FLOOD ZONE X
BEDROOMS : 3.00 PROPOSED USE : SFD
SEPTIC - EXISTING? : NEW WATER SUPPLY : UNKNOWN

PERMIT: CPSF 01 CP * SFD

TYP/SQ	REQUESTED COMPLETED	INSP RESULT	DESCRIPTION RESULTS/COMMENTS
B101 01	3/31/10	RD	R*BLDG FOOTING / TEMP SVC POLE VRU #: 001902436
	3/31/10	CA	T/S: 03/31/2010 01:16 PM RDCONTE CUSTOMER CANCELED AND ROLLED TO 04/01/10
B101 02	4/01/10	TI	R*BLDG FOOTING / TEMP SVC POLE TIME: 17:00 VRU #: 001903376
	4-1-10	APJH	T/S: 03/31/2010 01:17 PM RDCONTE <i>T-pole passed</i>

COMMENTS AND NOTES

Charnetzky Custom Homes, LLC



TO: Jimmy Hall
Fax 910 893-2793
From Lyndia
Fax 919 285-2338

Number of Pages 3 including cover

Please confirm receipt

Telephone # 919 285-2338

Thank you.

Lot

40
R

Stone-Cross

Builds: ~~XXXXXXXXXXXX~~
 Contractor: ~~XXXXXXXXXXXX~~
 Anderson Creek Development

Evaluation of Foster Capacity

3-31-10

FOSTER FED DEK POSTS



WCSUNNELL
 TRIMST

NOT TO SCALE

EQUIPMENT CODE DUAL MASS
 OCP

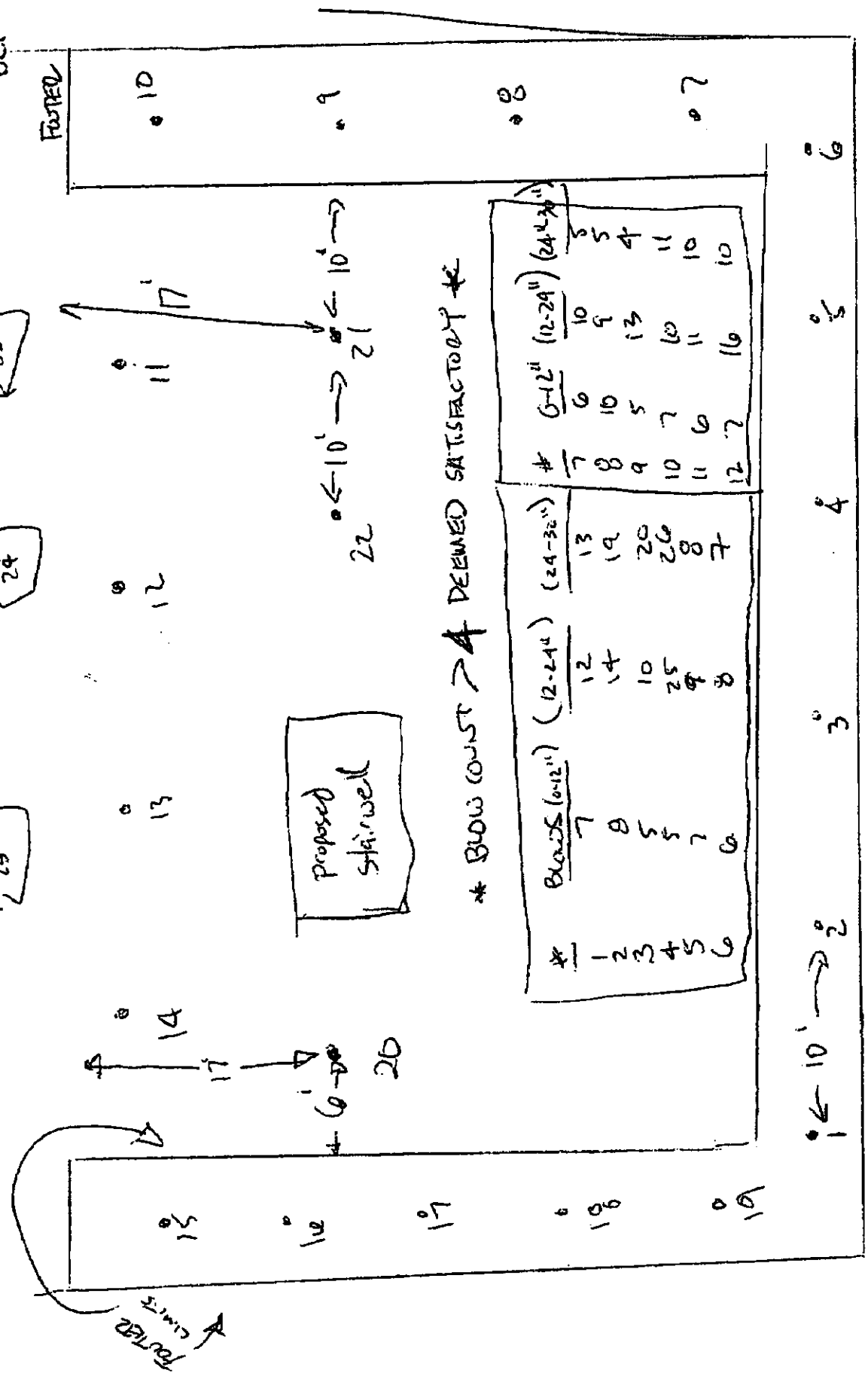

* BLOW COUNT > 4 DEEMED SATISFACTORY *

#	BLOW COUNT (0-12") (12-24")	(24-36")	(36-48")
7	6	10	5
8	10	9	5
9	5	13	4
10	7	10	11
11	6	11	10
12	7	16	10
13	12	13	7
14	14	20	8
15	10	26	7
16	25	9	8
17	9	8	6

* REST OF DATA ON REVERSE SIDE *

FOURTH OF HOUSE

PAGE 2

Project: Anderson Creeks Development
ID:
Location

25 $\frac{0.12^4}{5}$
 $\frac{12^{11} 29^2}{9}$
 $\frac{24-23^{14}}{11}$

Station	Lane	Location	Interval (cm)		Interval (in)		blows
			from	to	from	to	
		13	0.0	30.5	0.0	12.0	6
			30.5	61	12.0	24.0	6
			91.5	122	24.0	30.0 30	5
		14	0.0	30.5	0.0	12.0	5
			30.5	61	12.0	24.0	6
			91.5	122	24.0	30.0 30	4
		15	0.0	30.5	0.0	12.0	6
			30.5	61	12.0	24.0	7
			91.5	122	24.0	30.0 30	5
		16	0.0	30.5	0.0	12.0	7
			30.5	61	12.0	24.0	12
			91.5	122	24.0	30.0 30	13
		17	0.0	30.5	0.0	12.0	5
			30.5	61	12.0	24.0	10
			91.5	122	24.0	30.0 30	10
		18	0.0	30.5	0.0	12.0	8
			30.5	61	12.0	24.0	23
			91.5	122	24.0	30.0 30	14
		19	0.0	30.5	0.0	12.0	7
			30.5	61	12.0	24.0	9
			91.5	122	24.0	30.0 30	10
		20	0	30.5	0	12	6
			30.5	61	12	24	7
			91.5	122	24	30 30	6
		21	0	30.5	0	12	5
			30.5	61	12	24	6
			91.5	122	24	30 30	4
		22	0	30.5	0	12	4
			30.5	61	12	24	8
			91.5	122	24	30 30	6

23

0	12	9
12	24	15
24	30	5
0	12	4
12	24	4
24	30	10

24

ADDRESS : 320 COBBLESTONE DR
 CONTRACTOR : CHARNETZKY CUSTOM HOMES LLC
 OWNER : STONECROSS LLC
 PARCEL : 01-0535-14- -0100- -15-
 APPL NUMBER: 06-50014024 CP NEW RESIDENTIAL (SFD)

SUBDIV: STONE CROSS
 PHONE : (252) 478-4045
 PHONE :

DIRECTIONS : STONECROSS LOT 1. 210S TOWARDS SPRING
 LAKE RIGHT ON RAY RD RIGHT ON OVERHILLS
 TURN LEFT INTO STONECROSS ON STONECROSS
 DRIVE RIGHT ON COBBLESTONE LOT ON LEFT.
 #40R -A.DRIGGERS

STRUCTURE: 000 000 56X65 3BR SFD BASEMENT W/ GARAGE & DECK

FLOOD ZONE : FLOOD ZONE X
 # BEDROOMS : 3.00 PROPOSED USE : SFD
 SEPTIC - EXISTING? : NEW WATER SUPPLY : UNKNOWN

PERMIT: CPSF 01 CP * SFD

TYP/SQ	REQUESTED COMPLETED	INSP RESULT	DESCRIPTION RESULTS/COMMENTS
B101 01	3/31/10	RD	R*BLDG FOOTING / TEMP SVC POLE VRU #: 001902436
	3/31/10	CA	T/S: 03/31/2010 01:16 PM RDCONTE CUSTOMER CANCELLED AND ROLLED TO 04/01/10
B101 02	4/01/10	TI	R*BLDG FOOTING / TEMP SVC POLE TIME: 17:00 VRU #: 001903376
	4-1-10	CA JV	T/S: 03/31/2010 01:17 PM RDCONTE
B103 01	4/05/10	TI	R*BLDG FOUND & TEMP SVC POLE TIME: 17:00 VRU #: 001904226
	4-5-10	CA JV	T/S: 04/01/2010 01:58 PM NTART
B111 01	4/05/10	TI	R*BLDG SLAB INSP TIME: 17:00 VRU #: 001904200
	4-5-10	CA JV	T/S: 04/01/2010 01:57 PM NTART T/S: 04/01/2010 01:58 PM NTART WILL BE FOR THE BASEMENT.....
			Per Tom COMMENTS AND NOTES

ADDRESS : 320 COBBLESTONE DR SUBDIV: STONE CROSS
 CONTRACTOR : CHARNETZKY CUSTOM HOMES LLC PHONE : (252) 478-4045
 OWNER : STONECROSS LLC PHONE :
 PARCEL : 01-0535-14- -0100- -15-
 APPL NUMBER: 06-50014024 CP NEW RESIDENTIAL (SFD)

DIRECTIONS : STONECROSS LOT 1. 210S TOWARDS SPRING
 LAKE RIGHT ON RAY RD RIGHT ON OVERHILLS
 TURN LEFT INTO STONECROSS ON STONECROSS
 DRIVE RIGHT ON COBBLESTONE LOT ON LEFT.
 #40R -A.DRIGGERS

STRUCTURE: 000 000 56X65 3BR SFD BASEMENT W/ GARAGE & DECK
 FLOOD ZONE : FLOOD ZONE X
 # BEDROOMS : 3.00 PROPOSED USE : SFD
 SEPTIC - EXISTING? : NEW WATER SUPPLY : UNKNOWN

PERMIT: CPSF 01 CP * SFD

TYP/SQ	REQUESTED COMPLETED	INSP RESULT	DESCRIPTION RESULTS/COMMENTS
B101 01	3/31/10	RD	R*BLDG FOOTING / TEMP SVC POLE VRU #: 001902436
	3/31/10	CA	T/S: 03/31/2010 01:16 PM RDCONTE CUSTOMER CANCELED AND ROLLED TO 04/01/10
B101 02	4/01/10	JH	R*BLDG FOOTING / TEMP SVC POLE TIME: 17:00 VRU #: 001903376
	4/01/10	AP	T/S: 03/31/2010 01:17 PM RDCONTE t-pole passed 10 03:28 PM JHALL
B103 01	4/05/10	JH	R*BLDG FOUND & TEMP SVC POLE TIME: 17:00 VRU #: 001904226
	4/05/10	CA	T/S: 04/01/2010 01:58 PM NTART per Tom
B111 01	4/05/10	JH	R*BLDG SLAB INSP TIME: 17:00 VRU #: 001904200
	4/05/10	CA	T/S: 04/01/2010 01:57 PM NTART T/S: 04/01/2010 01:58 PM NTART WILL BE FOR THE BASEMENT..... per Tom
B103 02	4/05/10	TI	R*BLDG FOUND & TEMP SVC POLE TIME: 17:00 VRU #: 001905272
	4-6-10	APJA	T/S: 04/05/2010 01:57 PM RDCONTE
B111 02	4/06/10	TI	R*BLDG SLAB INSP TIME: 17:00 VRU #: 001905264
	4-6-10	APJD	T/S: 04/05/2010 01:56 PM RDCONTE

COMMENTS AND NOTES

ADDRESS : 320 COBBLESTONE DR SUBDIV: STONE CROSS
 CONTRACTOR : CHARNETZKY CUSTOM HOMES LLC PHONE : (252) 478-4045
 OWNER : STONECROSS LLC PHONE :
 PARCEL : 01-0535-14- -0100- -15-
 APPL NUMBER: 06-50014024 CP NEW RESIDENTIAL (SFD)
 DIRECTIONS : STONECROSS LOT 1. 210S TOWARDS SPRING
 LAKE RIGHT ON RAY RD RIGHT ON OVERHILLS
 TURN LEFT INTO STONECROSS ON STONECROSS
 DRIVE RIGHT ON COBBLESTONE LOT ON LEFT.
 #40R -A.DRIGGERS

STRUCTURE: 000 000 56X65 3BR SFD. BASEMENT W/ GARAGE & DECK

FLOOD ZONE : FLOOD ZONE X
 # BEDROOMS : 3.00 PROPOSED USE : SFD
 SEPTIC - EXISTING? : NEW WATER SUPPLY : UNKNOWN

PERMIT: CPSF 01 CP * SFD









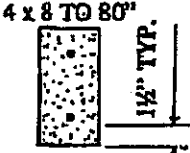

TYP/SQ	REQUESTED COMPLETED	INSP RESULT	DESCRIPTION RESULTS/COMMENTS
B101 01	3/31/10 3/31/10	RD CA	R*BLDG FOOTING / TEMP SVC POLE VRU #: 001902436 T/S: 03/31/2010 01:16 PM RDCONTE CUSTOMER CANCELLED AND ROLLED TO 04/01/10
B101 02	4/01/10 4/01/10	JH AP	R*BLDG FOOTING / TEMP SVC POLE TIME: 17:00 VRU #: 001903376 T/S: 03/31/2010 01:17 PM RDCONTE t-pole passed10 03:28 PM JHALL
B103 01	4/05/10 4/05/10	JH CA	R*BLDG FOUND & TEMP SVC POLE TIME: 17:00 VRU #: 001904226 T/S: 04/01/2010 01:58 PM NTART per Tom
B111 01	4/05/10 4/05/10	JH CA	R*BLDG SLAB INSP TIME: 17:00 VRU #: 001904200 T/S: 04/01/2010 01:57 PM NTART T/S: 04/01/2010 01:58 PM NTART WILL BE FOR THE BASEMENT..... per Tom
B103 02	4/06/10 4/06/10	JH AP	R*BLDG FOUND & TEMP SVC POLE TIME: 17:00 VRU #: 001905272 T/S: 04/05/2010 01:57 PM RDCONTE
B111 02	4/06/10 4/06/10	JH AP	R*BLDG SLAB INSP TIME: 17:00 VRU #: 001905264 T/S: 04/05/2010 01:56 PM RDCONTE
A814 01	4/08/10	TI	ADDRESS CONFIRMATION TIME: 17:00 VRU #: 001906700 T/S: 04/07/2010 01:44 PM JBROCK
B105 01	4/08/10 <u>4-8-10</u>	TI <u>APR</u>	R*OPEN FLOOR TIME: 17:00 VRU #: 001906718 T/S: 04/07/2010 01:44 PM JBROCK

COMMENTS AND NOTES

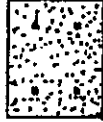
Martinsville Concrete Products, Inc.

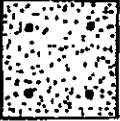
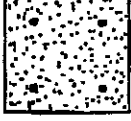
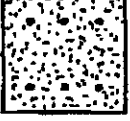
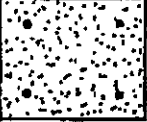
Enail to Jerry

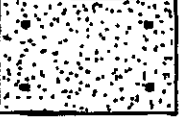
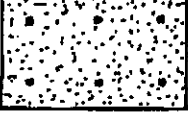
page 5

<p>CLEAR SPAN TO 56" LINTEL LENGTHS - 48" - 56" - 64" - 80"</p>	<p>CLEAR SPAN TO 57" TO 80" LINTEL LENGTH - 96"</p>	<p>CLEAR SPAN TO 81" TO 128" LINTEL LENGTHS - 112" - 128" - 144"</p>
<p>4 x 8 TO 80"  2 NO. 3 BARS</p>	<p>4 x 8 TO 96"  2 NO. 3 BARS</p>	<p>4 x 8" TO 144"  2 NO. 3 BARS</p>
<p>6 x 8" TO 80"  4 NO. 3 BARS</p>	<p>6 x 8 TO 96"  4 NO. 3 BARS</p>	<p>6 x 8" TO 144"  4 NO. 4 BARS</p>
<p>8 x 8" TO 80"  4 NO. 4 BARS</p>	<p>8 x 8" TO 96"  4 NO. 4 BARS</p>	<p>8 x 8" TO 144"  6 NO. 4 BARS</p>
<p>10 x 8 TO 80"  4 NO. 4 BARS</p>	<p>10 x 8" TO 96"  6 NO. 4 BARS</p>	<p>10 x 8 TO 144"  8 NO. 4 BARS</p>
<p>12 x 8" TO 80"  4 NO. 4 BARS</p>	<p>12 x 8" TO 96"  6 NO. 4 BARS</p>	<p>12 x 8" TO 144"  8 NO. 4 BARS</p>

ADDRESS : 320 COBBLESTONE DR
CONTRACTOR : CHARNETZKY CUSTOM HOMES LLC
OWNER : STONECROSS LLC
PARCEL : 01-0535-14- -0100- -15-
APPL NUMBER: 06-50014024 CP NEW RESIDENTIAL (SFD)

SUBDIV: STONE CROSS
PHONE : (252) 478-4045
PHONE :

DIRECTIONS : STONECROSS LOT 1. 210S TOWARDS SPRING
LAKE RIGHT ON RAY RD RIGHT ON OVERHILLS
TURN LEFT INTO STONECROSS ON STONECROSS
DRIVE RIGHT ON COBBLESTONE LOT ON LEFT.
#40R -A.DRIGGERS

STRUCTURE: 000 000 56X65 3BR SFD BASEMENT W/ GARAGE & DECK

FLOOD ZONE : FLOOD ZONE X
BEDROOMS : 3.00
SEPTIC - EXISTING? : NEW
PROPOSED USE : SFD
WATER SUPPLY : UNKNOWN

PERMIT: CPSF 01 CP * SFD

NO	DATE	BY	DESCRIPTION	TIME	VRU #
B101 01	3/31/10	RD	R*BLDG FOOTING / TEMP SVC POLE	01:16 PM	001902436
	3/31/10	CA	T/S: 03/31/2010 01:16 PM RDCONTE		
			CUSTOMER CANCELED AND ROLLED TO 04/01/10		
B101 02	4/01/10	JH	R*BLDG FOOTING / TEMP SVC POLE	01:17 PM	001903376
	4/01/10	AP	T/S: 03/31/2010 01:17 PM RDCONTE		
			t-pole passed 10 03:28 PM JHALL		
B103 01	4/05/10	JH	R*BLDG FOUND & TEMP SVC POLE	01:58 PM	001904226
	4/05/10	CA	T/S: 04/01/2010 01:58 PM NTART		
			per Tom		
B111 01	4/05/10	JH	R*BLDG SLAB INSP	01:57 PM	001904200
	4/05/10	CA	T/S: 04/01/2010 01:57 PM NTART		
			T/S: 04/01/2010 01:58 PM NTART		
			WILL BE FOR THE BASEMENT.....		
			per Tom		
B103 02	4/06/10	JH	R*BLDG FOUND & TEMP SVC POLE	01:57 PM	001905272
	4/06/10	AP	T/S: 04/05/2010 01:57 PM RDCONTE		
B111 02	4/06/10	JH	R*BLDG SLAB INSP	01:56 PM	001905264
	4/06/10	AP	T/S: 04/05/2010 01:56 PM RDCONTE		
A814 01	4/08/10	TW	ADDRESS CONFIRMATION	04:59 PM	001906700
	4/09/10	AP	T/S: 04/07/2010 01:44 PM JBROCK		
			316 cobblestone dr lot 40 R		
			spring lake 28390		
			T/S: 04/09/2010 04:59 PM TWARD		
B105 01	4/08/10	BS	R*OPEN FLOOR	12:35 PM	001906718
	4/08/10	AP	T/S: 04/07/2010 01:44 PM JBROCK		
			T/S: April 08, 2010 12:35 PM BSUTTON		
B101 03	4/12/10	TI	R*BLDG FOOTING / TEMP SVC POLE	02:04 PM	001908235
	4-12	AP	T/S: 04/09/2010 02:04 PM JBROCK		
B111 03	4/12/10	TI	R*BLDG SLAB INSP	02:04 PM	001908243
	4-12	AP	T/S: 04/09/2010 02:04 PM JBROCK		

COMMENTS AND NOTES

ADDRESS : 316 COBBLESTONE DR SUBDIV: STONE CROSS
 CONTRACTOR : CHARNETZKY CUSTOM HOMES LLC PHONE : (252) 478-4045
 OWNER : STONECROSS LLC PHONE :
 PARCEL : 01-0535-14- -0100- -15-
 APPL NUMBER: 06-50014024 CP NEW RESIDENTIAL (SFD)

DIRECTIONS : STONECROSS LOT 1. 210S TOWARDS SPRING
 LAKE RIGHT ON RAY RD RIGHT ON OVERHILLS
 TURN LEFT INTO STONECROSS ON STONECROSS
 DRIVE RIGHT ON COBBLESTONE LOT ON LEFT.
 #40R -A.DRIGGERS

STRUCTURE: 000 000 56X65 3BR SFD BASEMENT W/ GARAGE & DECK

FLOOD ZONE : FLOOD ZONE X
 # BEDROOMS : 3.00 PROPOSED USE : SFD
 SEPTIC - EXISTING? : NEW WATER SUPPLY : UNKNOWN

PERMIT: CPSF 01 CP * SFD

TYP/SQ	REQUESTED COMPLETED	INSP RESULT	DESCRIPTION RESULTS/COMMENTS
B101 01	3/31/10 3/31/10	RD CA	R*BLDG FOOTING / TEMP SVC POLE VRU #: 001902436 T/S: 03/31/2010 01:16 PM RDCONTE CUSTOMER CANCELLED AND ROLLED TO 04/01/10
B101 02	4/01/10 4/01/10	JH AP	R*BLDG FOOTING / TEMP SVC POLE TIME: 17:00 VRU #: 001903376 T/S: 03/31/2010 01:17 PM RDCONTE t-pole passed 03:28 PM JHALL
B103 01	4/05/10 4/05/10	JH CA	R*BLDG FOUND & TEMP SVC POLE TIME: 17:00 VRU #: 001904226 T/S: 04/01/2010 01:58 PM NTART per Tom
B111 01	4/05/10 4/05/10	JH CA	R*BLDG SLAB INSP TIME: 17:00 VRU #: 001904200 T/S: 04/01/2010 01:57 PM NTART T/S: 04/01/2010 01:58 PM NTART WILL BE FOR THE BASEMENT..... per Tom
B103 02	4/06/10 4/06/10	JH AP	R*BLDG FOUND & TEMP SVC POLE TIME: 17:00 VRU #: 001905272 T/S: 04/05/2010 01:57 PM RDCONTE
B111 02	4/06/10 4/06/10	JH AP	R*BLDG SLAB INSP TIME: 17:00 VRU #: 001905264 T/S: 04/05/2010 01:56 PM RDCONTE
A814 01	4/08/10 4/09/10	TW AP	ADDRESS CONFIRMATION TIME: 17:00 VRU #: 001906700 T/S: 04/07/2010 01:44 PM JBROCK 316 cobblestone dr lot 40 R spring lake 28390 T/S: 04/09/2010 04:59 PM TWARD
B105 01	4/08/10 4/08/10	BS AP	R*OPEN FLOOR TIME: 17:00 VRU #: 001906718 T/S: 04/07/2010 01:44 PM JBROCK T/S: April 08, 2010 12:35 PM BSUTTON
B101 03	4/12/10 4/12/10	KS AP	R*BLDG FOOTING / TEMP SVC POLE TIME: 17:00 VRU #: 001908235 T/S: 04/09/2010 02:04 PM JBROCK
B111 03	4/12/10 4/12/10	KS AP	R*BLDG SLAB INSP TIME: 17:00 VRU #: 001908243 T/S: 04/09/2010 02:04 PM JBROCK
R425 01	4/20/10 4/20/10	JH CA	FOUR TRADE ROUGH IN VRU #: 001912203 T/S: 04/20/2010 10:20 AM JBROCK CA PER BUILDER

ADDRESS . : 316 COBBLESTONE DR SUBDIV: STONE CROSS
CONTRACTOR : CHARNETZKY CUSTOM HOMES LLC PHONE : (252) 478-4045
OWNER . . : STONECROSS LLC PHONE :
PARCEL . . : 01-0535-14- -0100- -15-
APPL NUMBER: 06-50014024 CP NEW RESIDENTIAL (SFD)

TYP/SQ	REQUESTED COMPLETED	INSP RESULT	DESCRIPTION RESULTS/COMMENTS
R425 02	4/21/10 4/21/10	VC CA	FOUR TRADE ROUGH IN TIME: 17:00 VRU #: 001913284 T/S: 04/20/2010 10:20 AM JBROCK ----- T/S: 04/21/2010 09:26 AM VBROWN ----- CUST CALLED AND CAN INSP. SAID HE SPOKE WITH INSP WHO HAD HIM CALL UP HERE AND CAN INSP AND ROLL OVER FOR 4/22/10
R425 03	4/22/10 <u>4-22-10</u>	TI <u>DA JH</u>	FOUR TRADE ROUGH IN TIME: 17:00 VRU #: 001913763 T/S: 04/21/2010 09:27 AM VBROWN -----

----- COMMENTS AND NOTES -----

ADDRESS : 316 COBBLESTONE DR SUBDIV: STONE CROSS
 CONTRACTOR : CHARNETZKY CUSTOM HOMES LLC PHONE : (252) 478-4045
 OWNER : STONECROSS LLC PHONE :
 PARCEL : 01-0535-14- -0100- -15-
 APPL NUMBER: 06-50014024 CP NEW RESIDENTIAL (SFD)

DIRECTIONS : STONECROSS LOT 1. 210S TOWARDS SPRING
 LAKE RIGHT ON RAY RD RIGHT ON OVERHILLS
 TURN LEFT INTO STONECROSS ON STONECROSS
 DRIVE RIGHT ON COBBLESTONE LOT ON LEFT.
 #40R -A.DRIGGERS

STRUCTURE: 000 000 56X65 3BR SFD BASEMENT W/ GARAGE & DECK
 FLOOD ZONE : FLOOD ZONE X
 # BEDROOMS : 3.00 PROPOSED USE : SFD
 SEPTIC - EXISTING? : NEW WATER SUPPLY : UNKNOWN

PERMIT: CPSF 01 CP * SFD

TYP/SQ	REQUESTED COMPLETED	INSP RESULT	DESCRIPTION RESULTS/COMMENTS
B101 01	3/31/10 3/31/10	RD CA	R*BLDG FOOTING / TEMP SVC POLE VRU #: 001902436 T/S: 03/31/2010 01:16 PM RDCONTE CUSTOMER CANCELLED AND ROLLED TO 04/01/10
B101 02	4/01/10 4/01/10	JH AP	R*BLDG FOOTING / TEMP SVC POLE TIME: 17:00 VRU #: 001903376 T/S: 03/31/2010 01:17 PM RDCONTE t-pole passed 10 03:28 PM JHALL
B103 01	4/05/10 4/05/10	JH CA	R*BLDG FOUND & TEMP SVC POLE TIME: 17:00 VRU #: 001904226 T/S: 04/01/2010 01:58 PM NTART per Tom
B111 01	4/05/10 4/05/10	JH CA	R*BLDG SLAB INSP TIME: 17:00 VRU #: 001904200 T/S: 04/01/2010 01:57 PM NTART T/S: 04/01/2010 01:58 PM NTART WILL BE FOR THE BASEMENT..... per Tom
B103 02	4/06/10 4/06/10	JH AP	R*BLDG FOUND & TEMP SVC POLE TIME: 17:00 VRU #: 001905272 T/S: 04/05/2010 01:57 PM RDCONTE
B111 02	4/06/10 4/06/10	JH AP	R*BLDG SLAB INSP TIME: 17:00 VRU #: 001905264 T/S: 04/05/2010 01:56 PM RDCONTE
A814 01	4/08/10 4/09/10	TW AP	ADDRESS CONFIRMATION TIME: 17:00 VRU #: 001906700 T/S: 04/07/2010 01:44 PM JBROCK 316 cobblestone dr lot 40 R spring lake 28390 T/S: 04/09/2010 04:59 PM TWARD
B105 01	4/08/10 4/08/10	BS AP	R*OPEN FLOOR TIME: 17:00 VRU #: 001906718 T/S: 04/07/2010 01:44 PM JBROCK T/S: April 08, 2010 12:35 PM BSUTTON
B101 03	4/12/10 4/12/10	KS AP	R*BLDG FOOTING / TEMP SVC POLE TIME: 17:00 VRU #: 001908235 T/S: 04/09/2010 02:04 PM JBROCK
B111 03	4/12/10 4/12/10	KS AP	R*BLDG SLAB INSP TIME: 17:00 VRU #: 001908243 T/S: 04/09/2010 02:04 PM JBROCK
R425 01	4/20/10 4/20/10	JH CA	FOUR TRADE ROUGH IN VRU #: 001912203 T/S: 04/20/2010 10:20 AM JBROCK CA PER BUILDER

ADDRESS : 316 COBBLESTONE DR
 CONTRACTOR : CHARNETZKY CUSTOM HOMES LLC
 OWNER : STONECROSS LLC
 PARCEL : 01-0535-14- -0100- -15-
 APPL NUMBER: 06-50014024 CP NEW RESIDENTIAL (SFD)

SUBDIV: STONE CROSS
 PHONE : (252) 478-4045
 PHONE :

TYP/SQ	REQUESTED COMPLETED	INSP RESULT	DESCRIPTION RESULTS/COMMENTS
R425 02	4/21/10 4/21/10	VC CA	FOUR TRADE ROUGH IN TIME: 17:00 VRU #: 001913284 T/S: 04/20/2010 10:20 AM JBROCK ----- T/S: 04/21/2010 09:26 AM VBROWN ----- CUST CALLED AND CAN INSP. SAID HE SPOKE WITH INSP WHO HAD HIM CALL UP HERE AND CAN INSP AND ROLL OVER FOR 4/22/10
I129 01	4/22/10 4/22/10	RD CA	R*INSULATION INSPECTION TIME: 17:00 VRU #: 001914803 T/S: 04/22/2010 01:29 PM RDCONTE ----- OK TO INSULATE PER INSPECTOR T/S: 04/22/2010 01:29 PM RDCONTE ----- SET FOR WRONG DATE
R425 04	4/22/10 4/22/10	RD CA	FOUR TRADE ROUGH IN TIME: 17:00 VRU #: 001914795 T/S: 04/22/2010 01:28 PM RDCONTE ----- OK TO INSULATE PER INSPECTOR T/S: 04/22/2010 01:30 PM RDCONTE ----- SET FOR WRONG DATE
R425 03	4/22/10 4/22/10	JH DA	FOUR TRADE ROUGH IN TIME: 17:00 VRU #: 001913763 T/S: 04/21/2010 09:27 AM VBROWN ----- X Need to support trunk line in house every 64". X Insulate water lines & traps in basement or insulate knee walls in basement. X Ridgebeam can not be wider than rafters.
I129 02	4/23/10 <u>4-23-10</u>	TI <u>AP JV</u>	R*INSULATION INSPECTION TIME: 17:00 VRU #: 001914829 T/S: 04/22/2010 01:31 PM RDCONTE -----
R425 05	4/23/10 <u>4-23-10</u>	TI <u>AP JV</u>	FOUR TRADE ROUGH IN TIME: 17:00 VRU #: 001914811 T/S: 04/22/2010 01:31 PM RDCONTE -----

COMMENTS AND NOTES

919-365-5724
652-9600

Sp95.



TechData

PRODUCT SPECIFICATION SHEET



PureFlow® PolyAlloy PEX Crimp Fittings and Crimp Rings for ViegaPEX™ and ViegaPEX™ Ultra SDR-9 Cross-Linked Polyethylene (PEX)

Scope

This product specification designates the requirements for Viega PureFlow PolyAlloy PEX Crimp fittings and black copper crimp rings to be used as connections for ViegaPEX tubing in 3/8", 1/2", 3/4" and 1" sizes. These fittings are approved for use with both ASTM Standard F876 PEX tubing and F2262 PEX-Aluminum-PEX (PAX) tubing.

Materials

All PolyAlloy PEX Crimp fittings are manufactured from a polysulfone/polyphenylsulfone blended polymer (Acudel). The material is listed with NSF, International for potable water contact. PolyAlloy PEX Crimp fittings exhibit excellent resistance to the corrosive effects of water and are well suited for hot water applications. The black copper crimp rings are manufactured from UNS C10200 or UNS C12200 copper alloy. Rings are annealed to 35-45 Rockwell 15T scale for ease of crimping. The black coating is not a paint but a surface treatment which does not add to the dimensions of the ring.

Marking and Certification

PolyAlloy PEX Crimp fittings are marked with F877 and/or F2159 ASTM Standards and the NSF-pw mark indicating third party certification by NSF, International. Rings are marked with SDR-9 and/or PEX, F1807 and manufacturer's mark. NSF conducts random on-site inspections of Viega manufacturing facilities and independently tests PureFlow PolyAlloy PEX Crimp fittings for compliance with physical, performance, and toxicological standards.

Recommended Uses

PolyAlloy PEX Crimp fittings and black copper crimp rings are intended and recommended for use in potable water distribution systems with ViegaPEX and ViegaPEX Ultra tubing meeting the requirements of ASTM F876. Maximum design temperature and pressure ratings are 160 psi @ 73°F and 100 psi @ 180°F. For information on other hot and cold applications not listed here, consult with your Viega representative.

Handling and Installation

PolyAlloy PEX Crimp fittings are corrosion and impact resistant. However, they are still softer than metals and must be protected from UV exposure and petroleum products which can damage them. Use of these materials in hot and cold water distribution system must be in accordance with good plumbing practices, applicable code requirements, and current installation practices available from Viega. Contact a Viega representative or the applicable code enforcement bureau for information about approvals for specific applications.

Property	ASTM Test Method	Typical Values	
		English Units	SI Units
Specific Gravity	D 792	1.28	1.28
Melt Flow, g/10 min.	D 1238	12	12
Water Absorption, % in 24 hrs.	D 570	0.3	0.3
Tensile Strength @ Yield	D 638	11,200 psi	77 MPa
Tensile Modulus (psi MPa)	D 638	387,000 psi	2.67 MPa
Tensile Elongation @ yield, %	D 638	6.7	6.7
Tensile Elongation @ break, %	D 638	50	50
Flexural Strength @ yield, % (psi, MPa)	D 790	19,500 psi	134 MPa
Flexural Modulus, (psi, MPa)	D 790	402,000 psi	2.77 GPa
Izod Impact (Notched)	D 256	2.0 ft-lb/in	150 J/m
Heat Deflection Temp. @ 264 psi (1.8 MPa)	D 648	387°F	197°C
Thermal Conductivity	C 177	2.1 Btu-in/R ² /hr/°F	0.31 W/m-°C



VIEGA
301 N. Main, Floor 9
Wichita, KS 67202
Phone: 1-877-VIEGA-NA
Fax: 1-800-978-9817

service@viega.com
www.viega.com



TechData

PRODUCT SPECIFICATION SHEET



PureFlow® PolyAlloy PEX Crimp Fittings for ViegaPEX™ and ViegaPEX™ Ultra

Quality Assurance

When the product is marked with the ASTM F2159 designation, it affirms that the product was manufactured, inspected, sampled and tested in accordance with these specifications and has been found to meet the specified requirements.

Certification

NSF-pw - NSF International Performance and Health Effects (Standards 14 & 61)

NSF Certified to NSF-U.P. Code - approved for Uniform Plumbing Code, listed to ASTM F2159.

Intertek Testing Services (Warnock Hersey) - certification to CSA B137.5 (Canadian Standards Association)

NOTE: All fittings may not be listed with each organization shown.

Pressure Drop Table For PolyAlloy PEX Crimp Fittings Expressed in Equivalent Length of Tubing in Feet

SIZE	COUPLING	ELBOW	TEE RUN	TEE BRANCH
1/2"	7.1	16.5	7.2	17.9
3/4"	4.8	17.4	6.6	17.7
1"	4.5	18.0	6.0	17.0

This information is based on tubing nominal flow rate, (8 fps flow velocity)

GO/NO GO Gauges: Viega offers GO/NO GO gauge for easy testing of the finished crimp.

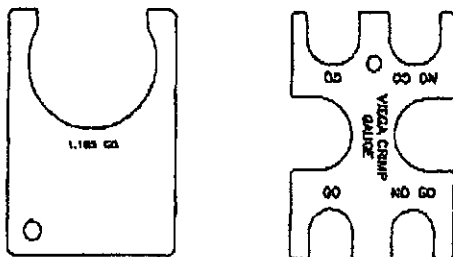

PureFlow PolyAlloy PEX Crimp Fittings Typical Fitting Insert Dimensions

SIZE	A	B	L
1/2"	.315	.473±.003	.700+.020
3/4"	.460	.668±.003	.700+.020
1"	.610	.866±.003	.850+.020

NOTE: Dimensions are in English units. Tolerances shown are ASTM requirements. Viega PolyAlloy PEX crimp fittings are manufactured within these specifications.

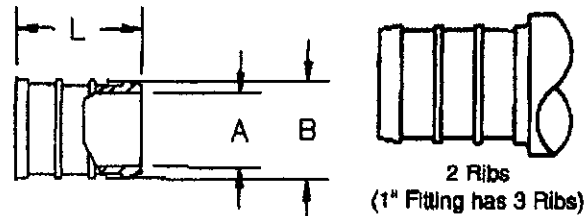

Copper Crimp Ring Dimensions Before Crimping

SIZE	D	W	T
1/2"	.750	.325	.056
3/4"	1.00	.325	.056
1"	1.25	.365	.049

All dimensions shown are nominal.

Crimped Diameter Dimensions

Final crimped outside diameters shall fall within these dimensions when measured with a micrometer or caliper.

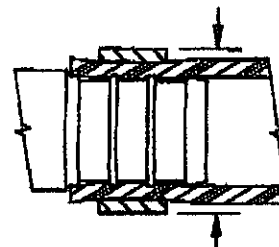

SIZE	MINIMUM	MAXIMUM
1/2"	ø 0.700"	ø 0.715"
3/4"	ø 0.945"	ø 0.960"
1"	ø 1.175"	ø 1.190"



VIEGA
 301 N. Main, Floor 9
 Wichita, KS 67202
 Phone: 1-877-VIEGA-NA
 Fax: 1-800-976-9817

service@viega.com
 www.viega.com



Polymer Barb x Barb x Barb Tee - QQPT__X

Specification Sheet

Tag _____

Dimensional Data: inches and [mm] are subject to manufacturing tolerances and change without notice.

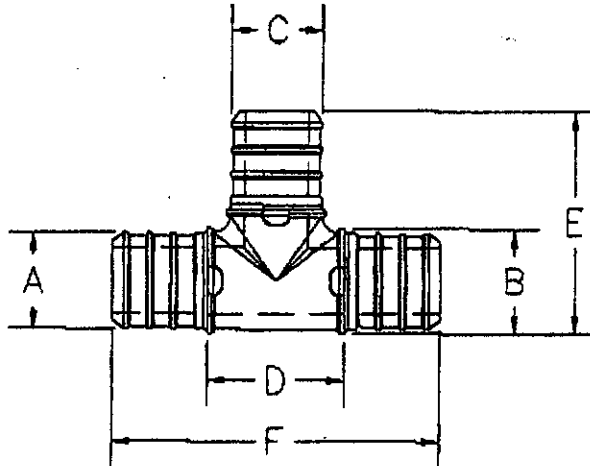

Part Number	Nominal Size	'A' In [mm]	'B' In [mm]	'C' In [mm]	'D' In [mm]	'E' In [mm]	'F' In [mm]
QQPT333X	1/2" x 1/2" x 1/2"	0.47 [11.9]	0.47 [11.9]	0.47 [11.9]	0.85 [21.6]	1.125 [28.6]	2.25 [57.2]
QQPT334X	1/2" x 1/2" x 3/4"	0.47 [11.9]	0.47 [11.9]	0.67 [17.0]	1.00 [25.4]	1.20 [30.5]	2.40 [61.0]
QQPT433X	3/4" x 1/2" x 1/2"	0.67 [17.0]	0.47 [11.9]	0.47 [11.9]	1.00 [25.4]	1.20 [30.5]	2.40 [61.0]
QQPT434X	3/4" x 1/2" x 3/4"	0.67 [17.0]	0.47 [11.9]	0.67 [17.0]	0.98 [24.9]	1.20 [30.5]	2.40 [61.0]
QQPT443X	3/4" x 3/4" x 1/2"	0.67 [17.0]	0.67 [17.0]	0.47 [11.9]	1.00 [25.4]	1.20 [30.5]	2.40 [61.0]
QQPT444X	3/4" x 3/4" x 3/4"	0.67 [17.0]	0.67 [17.0]	0.67 [17.0]	1.00 [25.4]	1.20 [30.5]	2.40 [61.0]
QQPT553X	1" x 1" x 1/2"	0.85 [21.6]	0.85 [21.6]	0.47 [11.9]	1.00 [25.4]	1.79 [45.5]	2.68 [68.1]
QQPT544X	1" x 3/4" x 3/4"	0.85 [21.6]	0.67 [17.0]	0.67 [17.0]	1.14 [29.0]	1.83 [46.5]	2.73 [69.3]
QQPT554X	1" x 1" x 3/4"	0.85 [21.6]	0.85 [21.6]	0.67 [17.0]	0.98 [24.9]	1.74 [44.2]	2.68 [68.1]
QQPT555X	1" x 1" x 1"	0.85 [21.6]	0.85 [21.6]	0.85 [21.6]	1.36 [35.5]	2.00 [50.8]	3.05 [77.5]

Engineering Specification: ZurnPEX™ polymer Barb x Barb x Barb tee. The QQPT__X tee is used to branch off a main line or change direction. Molded from Accudel. Meets NSF® and ASTM requirements.

Accessories

- ___ QCR3X 1/2" Copper Crimp Ring
- ___ QCR4X 3/4" Copper Crimp Ring

Rev. _____ Date: 11/15/04 C.N. No. 92854
Dwg. No. 92187 Prod. No. QQPT__X

ZURN PEX PLUMBING AND RADIANT HEATING SYSTEMS 1801 PITTSBURGH AVENUE, ERIE, PA, 16502 PHONE: 800/872-7277 FAX: 800/209-2148 WEBSITE: www.zurn.com
IN CANADA: ZURN INDUSTRIES LIMITED 3544 NASHUA DRIVE, MISSISSAUGA, ONTARIO L4V1L2 PHONE: 905/405-8272 FAX: 905/405-1292



Polymer PEX Coupling - QQPC_X Specification Sheet

Tag _____

Dimensional Data: Inches and [mm] are subject to manufacturing tolerances and change without notice.

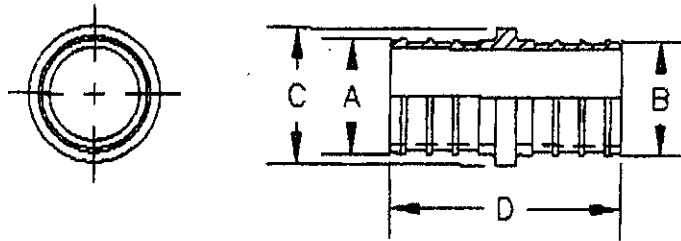

Part Number	Nominal Size	'A' in [mm]	'B' in [mm]	'C' in [mm]	'D' in [mm]
QQPC33X	1/2"	0.47 [11.9]	0.47 [11.9]	0.68 [17.3]	1.50 [38.1]
QQPC44X	3/4"	0.67 [17.0]	0.67 [17.0]	0.93 [23.6]	1.50 [38.1]
QQPC34X	1/2" x 3/4"	0.47 [11.9]	0.67 [17.0]	0.93 [23.6]	1.50 [38.1]
QQPC45X	3/4" x 1"	0.67 [17.0]	0.85 [21.6]	.95 [24.1]	1.83 [46.5]
QQPC55X	1" x 1"	0.85 [21.6]	0.85 [21.6]	.95 [24.1]	1.83 [46.5]

Engineering Specification: ZurnPEX™ polymer coupling. The QQPC_X coupling to connect PEX tubing to PEX tubing. Meets NSF® and ASTM requirements.

Accessories

- ___ QCR3X 1/2" Copper Crimp Ring
- ___ QCR4X 3/4" Copper Crimp Ring

Rev.	Date: 11/15/04	C.N. No. 92850
Dwg. No. 82189		Prod. No. QQPC_X



Polymer Barb x Barb Elbow - QQPE__X

Specification Sheet

Tag _____

Dimensional Data: inches and (mm) are subject to manufacturing tolerances and change without notice.

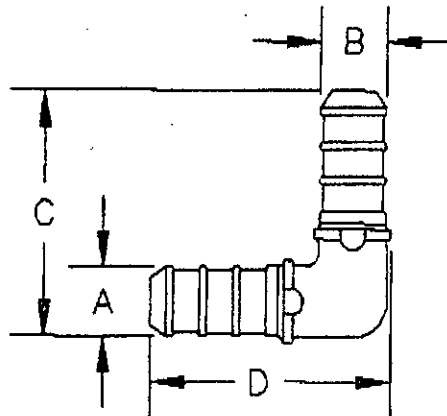

Part Number	Nominal Size	'A' in (mm)	'B' in (mm)	'C' in (mm)	'D' in (mm)
QQPE33X	1/2"	0.47 [11.9]	0.47 [11.9]	1.125 [28.6]	1.125 [28.6]
QQPE43X	3/4" x 1/2"	0.67 [17.0]	0.47 [11.9]	1.20 [30.5]	1.20 [30.5]
QQPE44X	3/4"	0.67 [17.0]	0.67 [17.0]	1.20 [30.5]	1.20 [30.5]
QQPE55X	1"	0.85 [21.6]	0.85 [21.6]	2.00 [50.8]	2.00 [50.8]

Engineering Specification: ZurnPEX™ polymer Barb x Barb elbow. The QQPE__X elbow is used to make sharp 90° bends. Molded from Accudel. Meets NSF® and ASTM requirements.

Accessories

- QCR3X 1/2" Copper Crimp Ring
- QCR4X 3/4" Copper Crimp Ring

Rev.	Date: 11/15/04	C.N. No. 92853
Dwg. No. 82186		Prod. No. QQPE__X

PureFlow® Warranty



VIEGA LIMITED WARRANTY PUREFLOW® POTABLE WATER PLUMBING SYSTEMS

Subject to the conditions and limitations in this Limited Warranty, VIEGA LLC (Viega) warrants to owners of real property in the United States that the components in its PureFlow Plumbing Systems (as described below) when properly installed by licensed plumbers in potable water systems, under normal conditions of use, shall be free from failure caused by manufacturing defects for a period of ten (10) years from date of installation. This warranty also applies to those supplying products covered by this warranty and installed on the property.

PureFlow Plumbing Systems and components covered by this ten year warranty are:

ViegaPEX™ and ViegaPEX™ ULTRA cross linked polyethylene (PEX) tubing, FostaPEX®, MANABLOC®, Minibloc™, or manifolds sold by Viega and using approved connections sold by Viega installed together in manifold plumbing systems.

ViegaPEX and ViegaPEX ULTRA cross linked polyethylene (PEX) tubing or FostaPEX installed with PEX Press fittings and PEX Press sleeves sold by Viega.

ViegaPEX and ViegaPEX ULTRA cross linked polyethylene (PEX) tubing and crimp insert fittings installed with copper crimp rings and meeting the specifications of ASTM F1807 and certified/listed for conformance with ANSI/NSF Standards No. 14/61 and Viega Poly alloy™ fittings.

Power tools and jaws used with PEX Press fittings are warranted by the manufacturer and Viega extends no separate warranty on those tools or jaws. Viega warrants that PEX Press hand tools sold by Viega, under normal conditions of use, shall be free from failure caused by manufacturing defects for a period of two (2) years from date of sale. Viega warrants that PEX Crimp hand tools sold by Viega, under normal conditions of use, shall be free from failure caused by manufacturing defects for a period of twelve (12) months from date of sale.

Viega warrants that properly installed PEX lav and closet risers and riser accessories manufactured and/or sold by Viega shall be free from failure caused by manufacturing defects for a period of two (2) years from date of installation.

Under this limited warranty, you only have a right to reimbursement if the failure or leak resulted from a manufacturing defect in the products covered by this warranty and the failure or leak occurred during the warranty period. You do not have a remedy or right of reimbursement under this warranty and the warranty does not apply if the failure or resulting damage is caused by (1) components in the plumbing system other than those manufactured or sold by Viega; (2) not designing, installing, inspecting or testing the system in accordance with Viega's installation instructions at the time of the installation, applicable code requirements and good plumbing practices; (3) improper handling and protection of the product prior to and during installation, inadequate freeze protection, exposure to water pressures or temperatures in excess of the limitations on the tubing or application of unauthorized solvents or chemicals; (4) acts of nature such as earthquakes, fire, flood, or lightning. In addition, the warranty does not apply if distribution lines and their connections to the MANABLOC system are not ViegaPEX or FostaPEX tubing or connections sold by Viega.

In the event of a leak or other failure in the system, it is the responsibility of the property owner to obtain and pay for repairs. Only if the warranty applies will Viega be responsible for reimbursement under this warranty. The part or parts which you claim failed should be kept and Viega contacted by writing to the address below or telephoning 1-877-843-4262 within thirty (30) days after the leak or other failure and identifying yourself as having a warranty claim. You should be prepared to ship, at your expense, the product which you claim failed due to a manufacturing defect, document the date of installation, and the amount of any claimed bills for which you claim reimbursement. Within a reasonable time after receiving the product, Viega will investigate the reasons for the failure, which includes the right to inspect the product at Viega and reasonable access to the site of damage in order to determine whether the warranty applies. Viega will notify you in writing of the results of its review.

In the event that Viega determines that the failure or leak and any resulting damages were the result of a manufacturing defect in the products and occurred during the time periods covered by this warranty, Viega will reimburse the property owner for reasonable repair or replacement charges to include drywall, flooring, and painting costs, as well as damages to personal property resulting from the failure or leak. VIEGA SHALL NOT BE LIABLE FOR CONSEQUENTIAL ECONOMIC LOSS DAMAGES UNDER ANY LEGAL THEORY AND WHETHER ASSERTED BY DIRECT ACTION, FOR CONTRIBUTION OR INDEMNITY OR OTHERWISE.

THE ABOVE LIMITED WARRANTY IS IN LIEU OF ALL OTHER WARRANTIES, EXPRESS OR IMPLIED, INCLUDING BUT NOT LIMITED TO, THE IMPLIED WARRANTIES OF MERCHANTABILITY AND FITNESS FOR A PARTICULAR PURPOSE. IF FOUND APPLICABLE, ANY IMPLIED WARRANTIES ARE LIMITED TO THE DURATION OF THE TIME LIMITS SET OUT IN THIS WRITTEN WARRANTY. Other than this limited warranty, Viega does not authorize any person or firm to create for it any other obligation or liability in connection with its products. This written warranty applies for the full term of the applicable warranty regardless of any change of ownership in the property.

Some states do not allow the exclusion or limitation of incidental or consequential damages or limitations on the duration of implied warranties in certain types of transactions, so the above exclusion or limitations may not apply to you. This limited warranty gives you specific legal rights and you also may have other rights which vary from state to state. This warranty shall be interpreted and applied under the law of the state in which the product is installed.

PXWARR 9/1/07

VIEGA • One Company... One Partner... Delivering System Solutions

301 N. Main, Floor 9 • Wichita, KS 67202 • Ph: 877-Viega-NA • Fax: 1-800-876-9817 • E-Mail: service@viega.com • www.viega.com

PureFlow PEX Crimp Fitting System

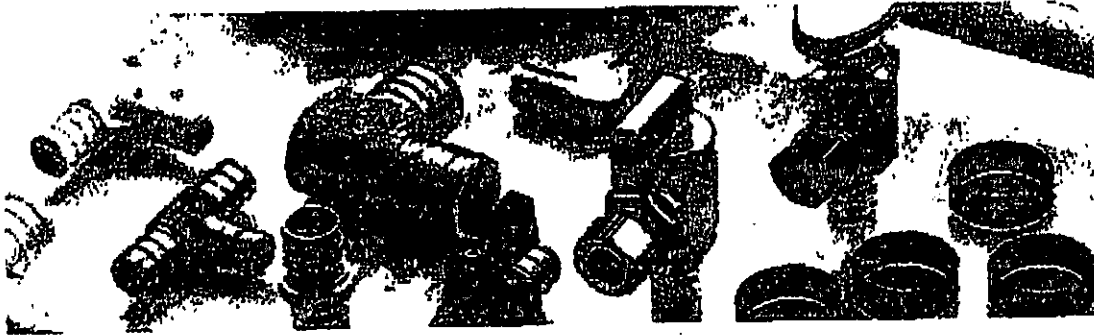

Viega offers the world's largest selection of PEX tubing, tools and fittings used to install the MANABLOC Water Distribution System. With more than 30 years of outstanding performance, Viega also continues to expand the choices of fittings, available with PureFlow Bronze PEX Press, Brass PEX Crimp and Poly Alloy PEX Crimp -- to meet a range of applications.

Two Ways to Make a Connection

PEX Crimp Fittings

The PureFlow PEX Crimp Fitting System, with more than 25 years of outstanding performance, continues to offer a reliable method for making PEX connections. Viega allows plumbers to expand their choice of fittings to both metallic and PolyAlloy, depending on which will best meet the environmental conditions in different areas of the country.

Like PEX Press, the PEX Crimp System, requires no glue, no solder, no torches and no lubricants. PureFlow PEX Crimp fittings range in size from 3/8" to 1" and hand tools are available in these sizes as well.

PolyAlloy Fittings are corrosion resistant, and ideal for aggressive soil and water conditions. These are available in tees, elbows, couplings and adapters from 3/8" to 1".

Viega North America - Viega Offices, Contact Information

Page 1 of 1

Viega North America

With nearly 500 sales and office staff in North America, you can be assured there's a Viega representative not far from where you are located.

Service Centers**Customer Service**

301 N Main, 9th Floor

Wichita, KS 67202

customerservice@viega.com

☎ 800-976-9819

☎ 800-976-9817

Viega Educational Facility

1800 Southwood Drive

Nashua, NH 03063

training@viega.com

☎ 877-843-4262 (ext. 200)

☎ 316-425-8468

Distribution Centers

2211 Viega Ave.

McPherson, KS 67460

☎ 800-775-5039

12040 Moya Blvd

Reno, NV 89506

☎ 877-843-4262

Other Contacts**Human Resources**

hr@viega.com

Media and Public Relations

press@viega.com

Technical Services

1800 Southwood Drive

Nashua, NH 03063

techservices@viega.com

☎ 877-843-4262 (ext. 350)

☎ 316-425-8466

59E Daniel Webster Hwy

Merrimack, NH 03054

☎ 877-843-4262

Inside Sales

insidesales@viega.com

Web Administrator/Webmaster

webadmin@viega.com

Technical Support

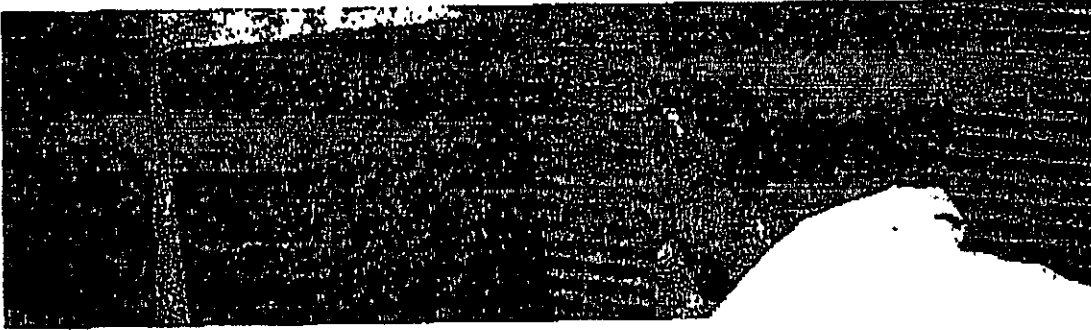

Viega's commitment begins with support. Our technical support team is prepared to provide the assistance required to get your job done and answer the questions you have along the way.

Viega's highly qualified support staff is experienced in all aspects of the plumbing and heating industry. Our support team is available to answer your questions about all our products lines: ProRadiant, ProPress Copper and Stainless, as well as PureFlow. Help is just a phone call or email away.

Fax: 316-425-8465

Phone: 877-843-4262 (ext. 350)

Local: 603-882-7171 (option 4)

Email: plumbing@viaga.com

ADDRESS : 316 COBBLESTONE DR SUBDIV: STONE CROSS
 CONTRACTOR : CHARNETZKY CUSTOM HOMES LLC PHONE : (252) 478-4045
 OWNER : STONECROSS LLC PHONE :
 PARCEL : 01-0535-14- -0100- -15-
 APPL NUMBER: 06-50014024 CP NEW RESIDENTIAL (SFD)

TYP/SQ	REQUESTED COMPLETED	INSP RESULT	DESCRIPTION RESULTS/COMMENTS
R425 02	4/21/10 4/21/10	VC CA	FOUR TRADE ROUGH IN TIME: 17:00 VRU #: 001913284 T/S: 04/20/2010 10:20 AM JBROCK ----- T/S: 04/21/2010 09:26 AM VBROWN ----- CUST CALLED AND CAN INSP. SAID HE SPOKE WITH INSP WHO HAD HIM CALL UP HERE AND CAN INSP AND ROLL OVER FOR 4/22/10
I129 01	4/22/10 4/22/10	RD CA	R*INSULATION INSPECTION TIME: 17:00 VRU #: 001914803 T/S: 04/22/2010 01:29 PM RDCONTE ----- OK TO INSULATE PER INSPECTOR T/S: 04/22/2010 01:29 PM RDCONTE ----- SET FOR WRONG DATE
R425 04	4/22/10 4/22/10	RD CA	FOUR TRADE ROUGH IN TIME: 17:00 VRU #: 001914795 T/S: 04/22/2010 01:28 PM RDCONTE ----- OK TO INSULATE PER INSPECTOR T/S: 04/22/2010 01:30 PM RDCONTE ----- SET FOR WRONG DATE
R425 03	4/22/10 4/22/10	JH DA	FOUR TRADE ROUGH IN TIME: 17:00 VRU #: 001913763 T/S: 04/21/2010 09:27 AM VBROWN ----- 1)Need to support trunk line in house every 64". 2)Insulate water lines & traps in basement or insulate knee walls in basement. 3)Ridgebeam can not be wider than rafters.
I129 02	4/23/10 4/23/10	JH AP	R*INSULATION INSPECTION TIME: 17:00 VRU #: 001914829 T/S: 04/22/2010 01:31 PM RDCONTE ----- T/S: 04/23/2010 01:13 PM DJOHNSON -----
R425 05	4/23/10 4/23/10	JH AP	FOUR TRADE ROUGH IN TIME: 17:00 VRU #: 001914811 T/S: 04/22/2010 01:31 PM RDCONTE ----- T/S: 04/23/2010 01:13 PM DJOHNSON -----
B101 04	4/30/10 <u>4/30/10</u>	TI <u>AP DT</u>	R*BLDG FOOTING / TEMP SVC POLE TIME: 17:00 VRU #: 001918671 T/S: 04/29/2010 01:07 PM NTART ----- WILL BE FOR THE FRONT PORCH.

COMMENTS AND NOTES

ADDRESS : 316 COBBLESTONE DR SUBDIV: STONE CROSS
 CONTRACTOR : CHARNETZKY CUSTOM HOMES LLC PHONE : (252) 478-4045
 OWNER : STONECROSS LLC PHONE :
 PARCEL : 01-0535-14- -0100- -15-
 APPL NUMBER: 06-50014024 CP NEW RESIDENTIAL (SFD)

DIRECTIONS : STONECROSS LOT 1. 210S TOWARDS SPRING
 LAKE RIGHT ON RAY RD RIGHT ON OVERHILLS
 TURN LEFT INTO STONECROSS ON STONECROSS
 DRIVE RIGHT ON COBBLESTONE LOT ON LEFT.
 #40R -A.DRIGGERS

STRUCTURE: 000 000 56X65 3BR SFD BASEMENT W/ GARAGE & DECK
 FLOOD ZONE : FLOOD ZONE X
 # BEDROOMS : 3.00 PROPOSED USE : SFD
 SEPTIC - EXISTING? : NEW WATER SUPPLY : UNKNOWN

PERMIT: CPSF 01 CP * SFD

TYP/SQ	REQUESTED COMPLETED	INSP RESULT	DESCRIPTION RESULTS/COMMENTS
B101 01	3/31/10 3/31/10	RD CA	R*BLDG FOOTING / TEMP SVC POLE VRU #: 001902436 T/S: 03/31/2010 01:16 PM RDCONTE ----- CUSTOMER CANCELD AND ROLLED TO 04/01/10
B101 02	4/01/10 4/01/10	JH AP	R*BLDG FOOTING / TEMP SVC POLE TIME: 17:00 VRU #: 001903376 T/S: 03/31/2010 01:17 PM RDCONTE ----- t-pole passed10 03:28 PM JHALL -----
B103 01	4/05/10 4/05/10	JH CA	R*BLDG FOUND & TEMP SVC POLE TIME: 17:00 VRU #: 001904226 T/S: 04/01/2010 01:58 PM NTART ----- per Tom -----
B111 01	4/05/10 4/05/10	JH CA	R*BLDG SLAB INSP TIME: 17:00 VRU #: 001904200 T/S: 04/01/2010 01:57 PM NTART ----- T/S: 04/01/2010 01:58 PM NTART ----- WILL BE FOR THE BASEMENT..... per Tom -----
B103 02	4/06/10 4/06/10	JH AP	R*BLDG FOUND & TEMP SVC POLE TIME: 17:00 VRU #: 001905272 T/S: 04/05/2010 01:57 PM RDCONTE -----
B111 02	4/06/10 4/06/10	JH AP	R*BLDG SLAB INSP TIME: 17:00 VRU #: 001905264 T/S: 04/05/2010 01:56 PM RDCONTE -----
A814 01	4/08/10 4/09/10	TW AP	ADDRESS CONFIRMATION TIME: 17:00 VRU #: 001906700 T/S: 04/07/2010 01:44 PM JBROCK ----- 316 cobblestone dr lot 40 R ----- spring lake 28390 T/S: 04/09/2010 04:59 PM TWARD -----
B105 01	4/08/10 4/08/10	BS AP	R*OPEN FLOOR TIME: 17:00 VRU #: 001906718 T/S: 04/07/2010 01:44 PM JBROCK ----- T/S: April 08, 2010 12:35 PM BSUTTON -----
B101 03	4/12/10 4/12/10	KS AP	R*BLDG FOOTING / TEMP SVC POLE TIME: 17:00 VRU #: 001908235 T/S: 04/09/2010 02:04 PM JBROCK -----
B111 03	4/12/10 4/12/10	KS AP	R*BLDG SLAB INSP TIME: 17:00 VRU #: 001908243 T/S: 04/09/2010 02:04 PM JBROCK -----
R425 01	4/20/10 4/20/10	JH CA	FOUR TRADE ROUGH IN VRU #: 001912203 T/S: 04/20/2010 10:20 AM JBROCK ----- CA PER BUILDER

ADDRESS : 316 COBBLESTONE DR SUBDIV: STONE CROSS
CONTRACTOR : CHARNETZKY CUSTOM HOMES LLC PHONE : (252) 478-4045
OWNER : STONECROSS LLC PHONE :
PARCEL : 01-0535-14- -0100- -15-
APPL NUMBER: 06-50014024 CP NEW RESIDENTIAL (SFD)

DIRECTIONS : STONECROSS LOT 1. 210S TOWARDS SPRING
LAKE RIGHT ON RAY RD RIGHT ON OVERHILLS
TURN LEFT INTO STONECROSS ON STONECROSS
DRIVE RIGHT ON COBBLESTONE LOT ON LEFT.
#40R -A.DRIGGERS

STRUCTURE: 000 000 56X65 3BR SFD BASEMENT W/ GARAGE & DECK

FLOOD ZONE : FLOOD ZONE X
BEDROOMS : 3.00 PROPOSED USE : SFD
SEPTIC - EXISTING? : NEW WATER SUPPLY : UNKNOWN

PERMIT: CPSF 01 CP * SFD

TYP/SQ	REQUESTED COMPLETED	INSP RESULT	DESCRIPTION RESULTS/COMMENTS
B101 01	3/31/10	RD	R*BLDG FOOTING / TEMP SVC POLE VRU #: 001902436
	3/31/10	CA	T/S: 03/31/2010 01:16 PM RDCONTE CUSTOMER CANCELLED AND ROLLED TO 04/01/10
B101 02	4/01/10	JH	R*BLDG FOOTING / TEMP SVC POLE TIME: 17:00 VRU #: 001903376
	4/01/10	AP	T/S: 03/31/2010 01:17 PM RDCONTE t-pole passed 03:28 PM JHALL
B103 01	4/05/10	JH	R*BLDG FOUND & TEMP SVC POLE TIME: 17:00 VRU #: 001904226
	4/05/10	CA	T/S: 04/01/2010 01:58 PM NTART per Tom
B111 01	4/05/10	JH	R*BLDG SLAB INSP TIME: 17:00 VRU #: 001904200
	4/05/10	CA	T/S: 04/01/2010 01:57 PM NTART T/S: 04/01/2010 01:58 PM NTART WILL BE FOR THE BASEMENT..... per Tom
B103 02	4/06/10	JH	R*BLDG FOUND & TEMP SVC POLE TIME: 17:00 VRU #: 001905272
	4/06/10	AP	T/S: 04/05/2010 01:57 PM RDCONTE
B111 02	4/06/10	JH	R*BLDG SLAB INSP TIME: 17:00 VRU #: 001905264
	4/06/10	AP	T/S: 04/05/2010 01:56 PM RDCONTE
A814 01	4/08/10	TW	ADDRESS CONFIRMATION TIME: 17:00 VRU #: 001906700
	4/09/10	AP	T/S: 04/07/2010 01:44 PM JBROCK 316 cobblestone dr lot 40 R spring lake 28390 T/S: 04/09/2010 04:59 PM TWARD
B105 01	4/08/10	BS	R*OPEN FLOOR TIME: 17:00 VRU #: 001906718
	4/08/10	AP	T/S: 04/07/2010 01:44 PM JBROCK T/S: April 08, 2010 12:35 PM BSUTTON
B101 03	4/12/10	KS	R*BLDG FOOTING / TEMP SVC POLE TIME: 17:00 VRU #: 001908235
	4/12/10	AP	T/S: 04/09/2010 02:04 PM JBROCK
B111 03	4/12/10	KS	R*BLDG SLAB INSP TIME: 17:00 VRU #: 001908243
	4/12/10	AP	T/S: 04/09/2010 02:04 PM JBROCK
R425 01	4/20/10	JH	FOUR TRADE ROUGH IN VRU #: 001912203
	4/20/10	CA	T/S: 04/20/2010 10:20 AM JBROCK CA PER BUILDER

ADDRESS : 316 COBBLESTONE DR
 CONTRACTOR : CHARNETZKY CUSTOM HOMES LLC
 OWNER : STONECROSS LLC
 PARCEL : 01-0535-14- -0100- -15-
 APPL NUMBER: 06-50014024 CP NEW RESIDENTIAL (SFD)

SUBDIV: STONE CROSS
 PHONE : (252) 478-4045
 PHONE :

TYP/SQ	REQUESTED COMPLETED	INSP RESULT	DESCRIPTION RESULTS/COMMENTS
R425 02	4/21/10 4/21/10	VC CA	FOUR TRADE ROUGH IN TIME: 17:00 VRU #: 001913284 T/S: 04/20/2010 10:20 AM JBROCK ----- T/S: 04/21/2010 09:26 AM VBROWN ----- CUST CALLED AND CAN INSP. SAID HE SPOKE WITH INSP WHO HAD HIM CALL UP HERE AND CAN INSP AND ROLL OVER FOR 4/22/10
I129 01	4/22/10 4/22/10	RD CA	R*INSULATION INSPECTION TIME: 17:00 VRU #: 001914803 T/S: 04/22/2010 01:29 PM RDCONTE ----- OK TO INSULATE PER INSPECTOR T/S: 04/22/2010 01:29 PM RDCONTE ----- SET FOR WRONG DATE
R425 04	4/22/10 4/22/10	RD CA	FOUR TRADE ROUGH IN TIME: 17:00 VRU #: 001914795 T/S: 04/22/2010 01:28 PM RDCONTE ----- OK TO INSULATE PER INSPECTOR T/S: 04/22/2010 01:30 PM RDCONTE ----- SET FOR WRONG DATE
R425 03	4/22/10 4/22/10	JH DA	FOUR TRADE ROUGH IN TIME: 17:00 VRU #: 001913763 T/S: 04/21/2010 09:27 AM VBROWN ----- 1)Need to support trunk line in house every 64". 2)Insulate water lines & traps in basement or insulate knee walls in basement. 3)Ridgebeam can not be wider than rafters.
I129 02	4/23/10 4/23/10	JH AP	R*INSULATION INSPECTION TIME: 17:00 VRU #: 001914829 T/S: 04/22/2010 01:31 PM RDCONTE ----- T/S: 04/23/2010 01:13 PM DJOHNSON -----
R425 05	4/23/10 4/23/10	JH AP	FOUR TRADE ROUGH IN TIME: 17:00 VRU #: 001914811 T/S: 04/22/2010 01:31 PM RDCONTE ----- T/S: 04/23/2010 01:13 PM DJOHNSON -----
B101 04	4/30/10 4/30/10	DT AP	R*BLDG FOOTING / TEMP SVC POLE TIME: 17:00 VRU #: 001918671 T/S: 04/29/2010 01:07 PM NTART ----- WILL BE FOR THE FRONT PORCH.
H824 01	5/10/10 5/10/10	OT AP	✓ ENVIR. OPERATIONS PERMIT TIME: 17:00 VRU #: 001924414 T/S: 05/11/2010 10:39 AM SSTEWARD ----- T/S: 05/11/2010 10:40 AM SSTEWARD -----
R429 01	5/21/10 <i>5-21-10</i>	TI <i>OA JH</i>	FOUR TRADE FINAL TIME: 17:00 VRU #: 001930445 T/S: 05/20/2010 01:36 PM RDCONTE -----

COMMENTS AND NOTES

ADDRESS : 316 COBBLESTONE DR SUBDIV: STONE CROSS
 CONTRACTOR : CHARNETZKY CUSTOM HOMES LLC PHONE : (252) 478-4045
 OWNER : STONECROSS LLC PHONE :
 PARCEL : 01-0535-14- -0100- -15-
 APPL NUMBER: 06-50014024 CP NEW RESIDENTIAL (SFD)
 DIRECTIONS : STONECROSS LOT 1. 210S TOWARDS SPRING
 LAKE RIGHT ON RAY RD RIGHT ON OVERHILLS
 TURN LEFT INTO STONECROSS ON STONECROSS
 DRIVE RIGHT ON COBBLESTONE LOT ON LEFT.
 #40R -A.DRIGGERS

STRUCTURE: 000 000 56X65 3BR SFD BASEMENT W/ GARAGE & DECK
 FLOOD ZONE : FLOOD ZONE X
 # BEDROOMS : 3.00 PROPOSED USE : SFD
 SEPTIC - EXISTING? : NEW WATER SUPPLY : UNKNOWN

PERMIT: CPSF 01 CP * SFD

TYP/SQ	REQUESTED COMPLETED	INSP RESULT	DESCRIPTION RESULTS/COMMENTS
B101 01	3/31/10	RD	R*BLDG FOOTING / TEMP SVC POLE VRU #: 001902436
	3/31/10	CA	T/S: 03/31/2010 01:16 PM RDCONTE ----- CUSTOMER CANCELLED AND ROLLED TO 04/01/10
B101 02	4/01/10	JH	R*BLDG FOOTING / TEMP SVC POLE TIME: 17:00 VRU #: 001903376
	4/01/10	AP	T/S: 03/31/2010 01:17 PM RDCONTE ----- t-pole passed10 03:28 PM JHALL -----
B103 01	4/05/10	JH	R*BLDG FOUND & TEMP SVC POLE TIME: 17:00 VRU #: 001904226
	4/05/10	CA	T/S: 04/01/2010 01:58 PM NTART ----- per Tom -----
B111 01	4/05/10	JH	R*BLDG SLAB INSP TIME: 17:00 VRU #: 001904200
	4/05/10	CA	T/S: 04/01/2010 01:57 PM NTART ----- T/S: 04/01/2010 01:58 PM NTART ----- WILL BE FOR THE BASEMENT..... per Tom -----
B103 02	4/06/10	JH	R*BLDG FOUND & TEMP SVC POLE TIME: 17:00 VRU #: 001905272
	4/06/10	AP	T/S: 04/05/2010 01:57 PM RDCONTE -----
B111 02	4/06/10	JH	R*BLDG SLAB INSP TIME: 17:00 VRU #: 001905264
	4/06/10	AP	T/S: 04/05/2010 01:56 PM RDCONTE -----
A814 01	4/08/10	TW	ADDRESS CONFIRMATION TIME: 17:00 VRU #: 001906700
	4/09/10	AP	✓ T/S: 04/07/2010 01:44 PM JBROCK ----- 316 cobblestone dr lot 40 R ----- spring lake 28390 ----- T/S: 04/09/2010 04:59 PM TWARD -----
B105 01	4/08/10	BS	R*OPEN FLOOR TIME: 17:00 VRU #: 001906718
	4/08/10	AP	T/S: 04/07/2010 01:44 PM JBROCK ----- T/S: April 08, 2010 12:35 PM BSUTTON -----
B101 03	4/12/10	KS	R*BLDG FOOTING / TEMP SVC POLE TIME: 17:00 VRU #: 001908235
	4/12/10	AP	T/S: 04/09/2010 02:04 PM JBROCK -----
B111 03	4/12/10	KS	R*BLDG SLAB INSP TIME: 17:00 VRU #: 001908243
	4/12/10	AP	T/S: 04/09/2010 02:04 PM JBROCK -----
R425 01	4/20/10	JH	FOUR TRADE ROUGH IN VRU #: 001912203
	4/20/10	CA	T/S: 04/20/2010 10:20 AM JBROCK ----- CA PER BUILDER
R425 02	4/21/10	VC	FOUR TRADE ROUGH IN TIME: 17:00 VRU #: 001913284

ADDRESS : 316 COBBLESTONE DR
CONTRACTOR : CHARNETZKY CUSTOM HOMES LLC
OWNER : STONECROSS LLC
PARCEL : 01-0535-14- -0100- -15-
APPL NUMBER: 06-50014024 CP NEW RESIDENTIAL (SFD)

SUBDIV: STONE CROSS
PHONE : (252) 478-4045
PHONE :

TYP/SQ	REQUESTED COMPLETED	INSP RESULT	DESCRIPTION RESULTS/COMMENTS
	4/21/10	CA	T/S: 04/20/2010 10:20 AM JBROCK T/S: 04/21/2010 09:26 AM VBROWN CUST CALLED AND CAN INSP. SAID HE SPOKE WITH INSP WHO HAD HIM CALL UP HERE AND CAN INSP AND ROLL OVER FOR 4/22/10
I129 01	4/22/10	RD	R*INSULATION INSPECTION TIME: 17:00 VRU #: 001914803
	4/22/10	CA	T/S: 04/22/2010 01:29 PM RDCONTE OK TO INSULATE PER INSPECTOR T/S: 04/22/2010 01:29 PM RDCONTE SET FOR WRONG DATE
R425 04	4/22/10	RD	FOUR TRADE ROUGH IN TIME: 17:00 VRU #: 001914795
	4/22/10	CA	T/S: 04/22/2010 01:28 PM RDCONTE OK TO INSULATE PER INSPECTOR T/S: 04/22/2010 01:30 PM RDCONTE SET FOR WRONG DATE
R425 03	4/22/10	JH	FOUR TRADE ROUGH IN TIME: 17:00 VRU #: 001913763
	4/22/10	DA	T/S: 04/21/2010 09:27 AM VBROWN 1)Need to support trunk line in house every 64". 2)Insulate water lines & traps in basement or insulate knee walls in basement. 3)Ridgebeam can not be wider than rafters.
I129 02	4/23/10	JH	R*INSULATION INSPECTION TIME: 17:00 VRU #: 001914829
	4/23/10	AP	T/S: 04/22/2010 01:31 PM RDCONTE T/S: 04/23/2010 01:13 PM DJOHNSON
R425 05	4/23/10	JH	FOUR TRADE ROUGH IN TIME: 17:00 VRU #: 001914811
	4/23/10	AP	T/S: 04/22/2010 01:31 PM RDCONTE T/S: 04/23/2010 01:13 PM DJOHNSON
B101 04	4/30/10	DT	R*BLDG FOOTING / TEMP SVC POLE TIME: 17:00 VRU #: 001918671
	4/30/10	AP	T/S: 04/29/2010 01:07 PM NTART WILL BE FOR THE FRONT PORCH.
H824 01	5/10/10	OT	✓ ENVIR. OPERATIONS PERMIT TIME: 17:00 VRU #: 001924414
	5/10/10	AP	T/S: 05/11/2010 10:39 AM SSTEWARD T/S: 05/11/2010 10:40 AM SSTEWARD
R429 01	5/21/10	JH	FOUR TRADE FINAL TIME: 17:00 VRU #: 001930445
	5/21/10	DA	T/S: 05/20/2010 01:36 PM RDCONTE 1)Need wind load sticker for garage doors. 2)Label AHU in attic. 3)Missing breakers in panel in basement for study & disposal 4)Panel in basement labeled incorrectly. 5)Need 2 ground rods @ meter. 6)Missing grounding bar for cable & phone.
R429 02	5/27/10	TI	FOUR TRADE FINAL TIME: 17:00 VRU #: 001932771
	5-27-10	AP	T/S: 05/25/2010 04:31 PM RDCONTE

COMMENTS AND NOTES

**COUNTY OF HARNETT
DEPARTMENT OF BUILDING INSPECTION
AND PLANNING/DEVELOPMENT
CERTIFICATE OF COMPLIANCE**

This certificate issued pursuant to the requirements of Section 307 of the North Carolina Administration Code and the Harnett County Zoning Ordinance certifies at the time of issuance this structure was in compliance with the various ordinances of the County of Harnett regulating development and building construction or use. For the following:

Use Classification: SFO

Conditional Use Permit No.: _____

Type of Construction: V

Building Permit No.: _____

Owner of Building: Charney & Custon Hwy

Electrical Permit No.: _____

Building Address: 316 Cobblestone Dr

Insulation Permit No.: _____

Zoning District: _____

Plumbing Permit No.: _____

Zoning Permit No.: _____

Mech. Permit No.: _____

Date: 5-27-10

Envir. C.O. No.: _____

James J. Hall
Building Official

14024
1204/005-90
Zoning Official