

**SOIL/SITE EVALUATION
 for ON-SITE WASTEWATER SYSTEM**

Owner: _____
 Address: _____
 Proposed Facility: _____ Design Flow (.1949): _____
 Location of Site: _____
 Water Supply: Public Individual Well
 Evaluation Method: Auger Boring Pit
 Type of Wastewater: Sewage Industrial Process

Applicant: _____
 Date Evaluated: _____
 Property Size: _____
 Property Recorded: _____
 Spring Other
 Cut
 Mixed

Profile #	1940 Landscape Position/Slope%	Horizon Depth (IN.)	SOIL MORPHOLOGY 1941		OTHER PROFILE FACTORS				Profile Class & LTAR
			1941 Structure/Texture	1941 Consistence Mineralogy	1942 Soil Wetness/Color	1943 Soil Depth (IN.)	1956 Sapro Class	1944 Restr. Horiz	
		0-16	G LS						PS .6
		16-24	SBK SCL	VRZ SS/MP					
		24-32	PM						PS .5
		0-32	G LS	VRZ NS/MP					
		32-44	SBK SCL	VRZ SS/MP					
		0-18							
		18-							
		0-35	G LS	VRZ NS/MP					.8
		35-37	SBK SCL	FR SS/SCL					.4
		37-44	PM						US

Description	Initial System	Repair System
Available Space (.1945)	✓	✓
System Type(s)	INNOV	PUMP INNOV
Site LTAR	.5	.5

2x40" @ 18"
 INNOV REPAIR

Other Factors (.1946): _____
 Site Classification (.1948): PS
 Evaluated By: OT
 Others Present: —

COMMENTS:

LANDSCAPE POSITIONS	GROUP	TEXTURES	.1955 LTAR	CONSISTENCE MOIST	WET
R-RIDGE	I	S-SAND	1.2 - 0.8	VFR-VERY FRIABLE	NS-NON-STICKY
S-SHOULDER SLOPE		LS-LOAMY SAND			
L-LINEAR SLOPE	II	SL-SANDY LOAM	0.8 - 0.6	FR-FRIABLE	SS-SLIGHTLY STICKY
FS-FOOT SLOPE		L-LOAM		FI-FIRM	S-STICKY
N-NOSE SLOPE					VFI-VERY FIRM
H-HEAD SLOPE	III	SI-SILT-	0.6 - 0.3	EFI-EXTREMELY FIRM	NP-NON-PLASTIC
CC-CONCLAVE SLOPE		SIL-SILT LOAM			SP-SLIGHTLY STICKY
CV-CONVEX SLOPE		CL-CLAY LOAM			P-PLASTIC
T-TERRACE		SCL-SANDY CLAY LOAM			VP-VERY PLASTIC
FP-FLOOD PLAN		SICL-SILTY CLAY LOAM			
	IV	SIC-SILTY CLAY	0.4 - 0.1		
		C-CLAY			
		SC-SANDY CLAY			

STRUCTURE

- SG-SINGLE GRAIN
- M-MASSIVE
- CR-CRUMB
- GR-GRANULAR
- SBK-SUBANGULAR BLOCKY
- ABK-ANGULAR BLOCKY
- PL-PLATY
- PR-PRISMATIC

MINERALOGY

- SLIGHTLY EXPANSIVE
- EXPANSIVE

Show profile locations and other site features (dimensions, reference or benchmark, and North).

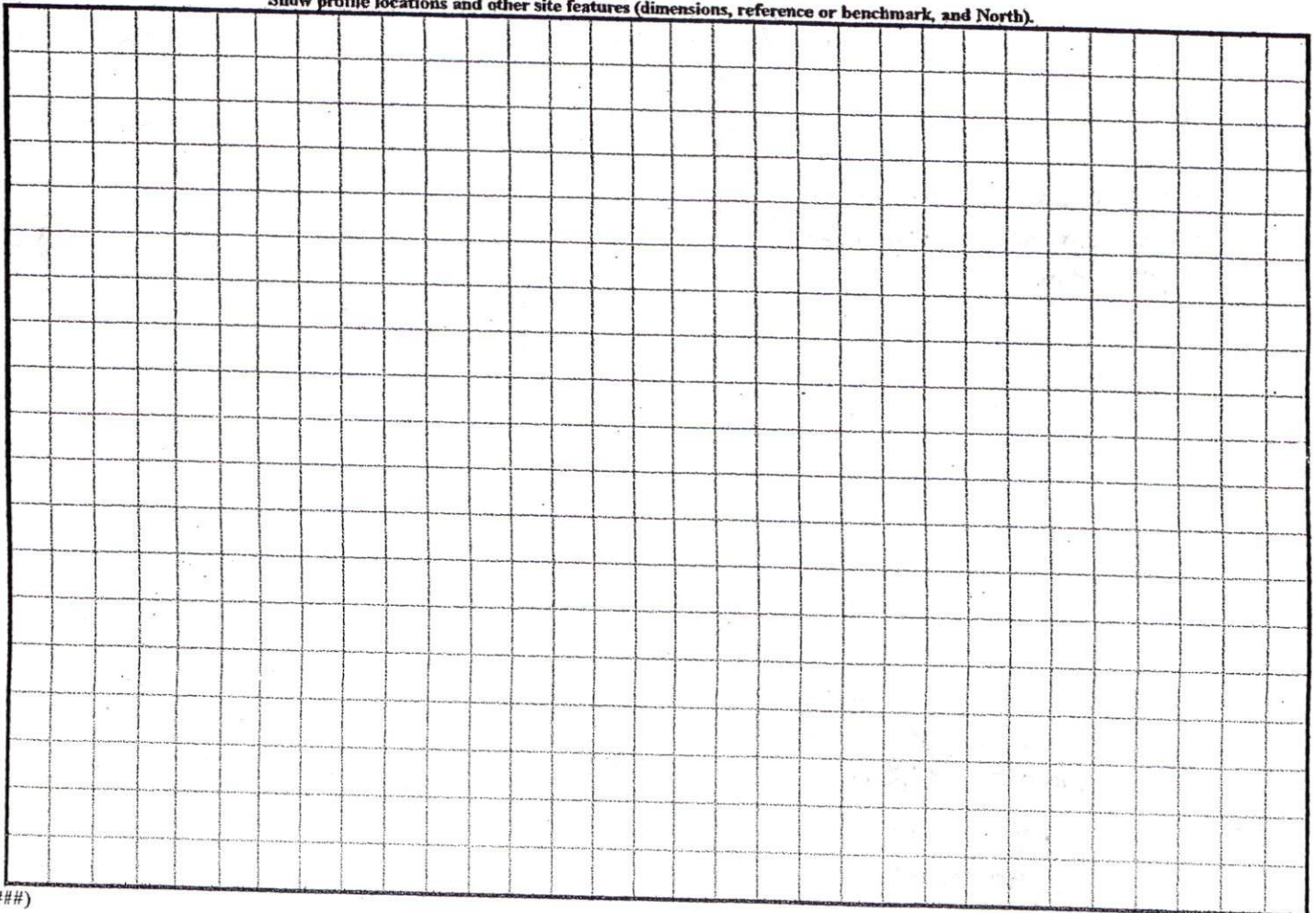

MAMIE BELL

Lot 14

66 AC

1" = 40'

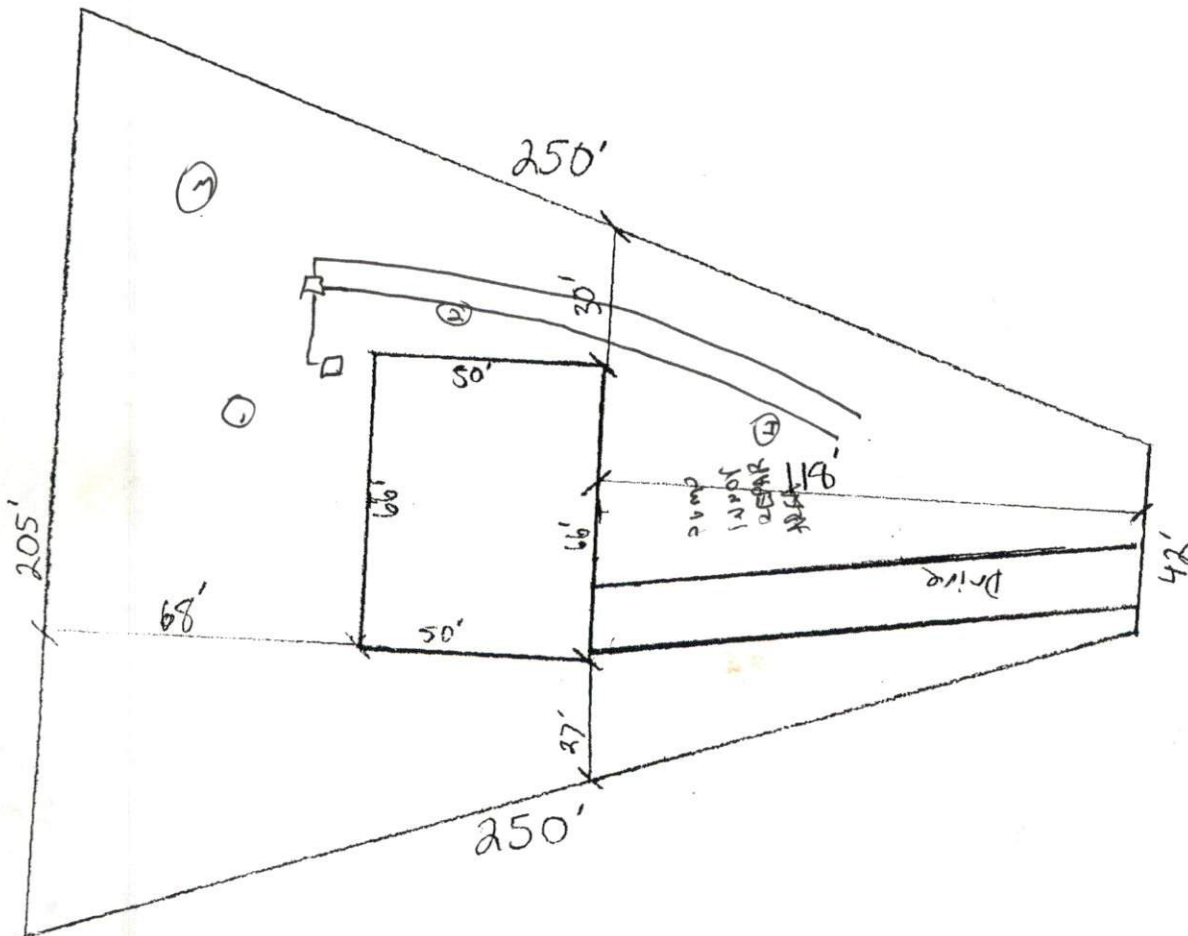

AVENUE BELL CIRCLE

SITE PLAN APPROVAL

DISTRICT RA30 USE SFD

#BEDROOMS _____

10/10/05 PKR

Date

Zoning Administrator