

Initial Application Date: 10/10/05

Application # 0550013195

Central Permitting 102 E. Front Street, Lillington, NC 27546 Phone: (910) 893-4759 Fax: (910) 893-2793 www.harnett.org
COUNTY OF HARNETT LAND USE APPLICATION 1065395

LANDOWNER: Mike Ray Mailing Address: 3417 Spring Hill Church
City: Lillington State: NC Zip: 27546 Phone #:

APPLICANT: Cape Fear Builders Mailing Address: 1116 Tysinger Rd
City: Lillington State: NC Zip: 27546 Phone #: 910-891-9600

PROPERTY LOCATION: SR #: 1791 SR Name: Old US 421
Address: 101 Mamie Bell Circle

Parcel: 130630 002915 PIN: 0630-64-5115 000

Zoning: RA30 Subdivision: Mamie Bell Ridge Lot #: 14 Lot Size: .68
Flood Plain: X Panel: 80 Watershed: n/a Deed Book/Page: OTR Plat Book/Page: 2003-1139

DIRECTIONS TO THE PROPERTY FROM LILLINGTON: Take Old 421 to Sanford
Go to Mamie Bell Ridge Subdivision Turn left
go to first left in Subdivision, (Mamie Bell circle)
Lot 14 is in the cul-de-sac

PROPOSED USE:
 SFD (Size 50x66) # Bedrooms 3 # Baths 2 Basement (w/wo bath) - Garage Deck Crawl Space / Slab
 Multi-Family Dwelling No. Units _____ No. Bedrooms/Unit _____
 Manufactured Home (Size _____ x _____) # of Bedrooms _____ Garage _____ Deck included
 Number of persons per household Sp6
 Business Sq. Ft. Retail Space _____ Type _____
 Industry Sq. Ft. _____ Type _____
 Church Seating Capacity _____ Kitchen _____
 Home Occupation (Size _____ x _____) # Rooms _____ Use _____
Additional Information: _____
 Accessory Building (Size _____ x _____) Use _____
 Addition to Existing Building (Size _____ x _____) Use _____
 Other _____

Additional Information:
Water Supply: County Well (No. dwellings _____) Other _____ Environmental Health Site Visit Date: _____

Sewage Supply: New Septic Tank Existing Septic Tank County Sewer Other _____
Erosion & Sedimentation Control Plan Required? YES NO

Property owner of this tract of land own land that contains a manufactured home w/in five hundred feet (500') of tract listed above? YES NO
Structures on this tract of land: Single family dwellings prop Manufactured homes _____ Other (specify) _____

Required Residential Property Line Setbacks:

	Minimum	Actual,
Front	35	<u>118'</u>
Rear	25	<u>68'</u>
Side	10	<u>27'</u>
Corner	20	<u>-</u>
Nearest Building	10	<u>-</u>

If permits are granted I agree to conform to all ordinances and the laws of the State of North Carolina regulating such work and the specifications or plans submitted. I hereby swear that the foregoing statements are accurate and correct to the best of my knowledge.

Josiah M. Garden
Signature of Owner or Owner's Agent

10/10/05
Date

This application expires 6 months from the initial date if no permits have been issued

A RECORDED SURVEY PLAT AND RECORDED DEED ARE REQUIRED WHEN APPLYING FOR A LAND USE APPLICATION
Please use Blue or Black Ink ONLY

08/05
10/11/05

MAMIE BELL

Lot 14

66 AC

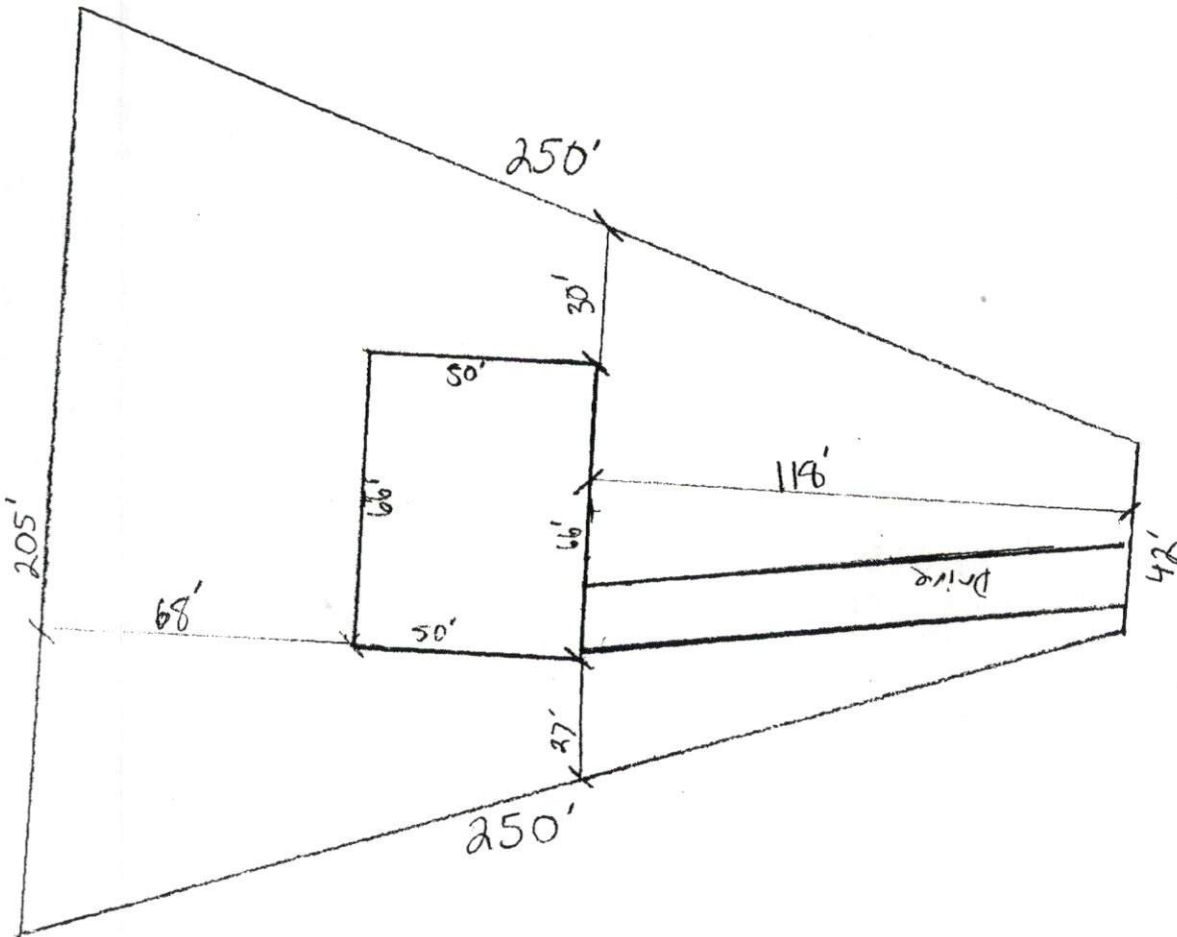

1" = 40'

AVENUE WITH CURB

SITE PLAN APPROVAL

DISTRICT RA30 USE SFD

#BEDROOMS _____

Date 10/10/05 PJR

Zoning Administrator

Harnett County Planning Department

PO Box 65, Lillington, NC 27546
910-893-7527

Notification Permit

Environmental Health New Septic Systems Test
Environmental Health Code 800

- Place "property flags" in each corner of lot. All property lines must be clearly flagged approximately every 50 feet between corners.
- Place "house corner flags" at each corner of where the house/manufactured home will sit. Use additional flagging to outline driveways, garages, decks, out buildings, swimming pools, etc.
- Place flags at locations as developed on site plan by Customer Service Technician and you.
- Place Environmental Health "orange" card in location that is easily viewed from road.
- If property is thickly wooded, Environmental Health requires that you clean out the undergrowth to allow the soil evaluation to be performed. Inspectors should be able to walk freely around site. *No grading of property should be done.*
- After preparing proposed site call the voice permitting system at 910-893-7527 and give code **800** for Environmental Health confirmation. Please note confirmation number given at end of recording for proof of request.
- To hear results, call IVR again. Once approved, proceed to Central Permitting for permits

Environmental Health Existing Tank Inspections
Environmental Health Code 800

- Place Environmental Health "orange" card in location that is easily viewed from road.
- Prepare for inspection by removing soil over door as diagram indicates. Loosen trap door cover. (Unless inspection is for a septic tank in a mobile home park)
- After preparing trapdoor call the voice permitting system at 910-893-7527 and give code **800** for Environmental Health confirmation. Please note confirmation number given at end of recording for proof of request.
- To hear results, call IVR again. Once approved, proceed to Central Permitting for permits

Health and Sanitation Inspections
Health and Sanitation Plan Review 826

- After submitting plans for food and lodging, call the voice permitting system at 910-893-7527 and give code **826** for Health and Sanitation confirmation. Please note confirmation number given at end of recording for proof of request.
- To hear results, call IVR again. Once approved, proceed to Central Permitting for permits

Fire Marshal Inspections
Fire Marshall Plan Review Code 804

- Call the voice permitting system at 910-893-7527 and give code **804** for plan review. Please note confirmation number given at end of recording for proof of request.
- To hear results, call IVR again. Once approved, proceed to Central Permitting for permits
- Pick up Fire Marshal's letter and place on job site until work is completed.

Public Utilities

- Place stake with "orange" tape/name thirty feet (30) from the center of the road at the location you wish to have water tap installed.
- Allow four to six weeks after application for water/sewer taps. Call Utilities at 893-7575 for technical assistance.

Building Inspections

- Call the voice permitting system at 910-893-7527 to schedule inspections. Please note confirmation number given at end of recording for proof of request.
- For new housing/set up permits must meet E 911 / Addressing guidelines prior to calling for final inspection.
- To hear results of inspections, call IVR again.

E911 Addressing
Addressing Confirmation Code 814

- Address numbers shall be mounted on the house, 3 inches high (5" for commercial).
- Numbers must be a contrasting color from house, must be clearly visible night and day at entrance of driveway if home is 100 ft or more from road, or if mailbox is on opposite side of road.
- Once you purchase permits and footing inspection has been approved call the voice permitting system at 910-893-7527 and give code **814** for address confirmation. This must be called in even if you have contacted E911 for verbal confirmation

Applicant Signature: Joseph M. Adams Date: 10/10/05