

HTE 05-5-11701

# IMPROVEMENT PERMIT

21723

Be it ordained by the Harnett County Board of Health as follows: Section III, Item B. "No Person shall begin construction of any building at which a septic tank system is to be used for disposal of sewage without first obtaining a written permit from the Harnett County Health Department."

Name: (owner) Home Works Custom Builders  New Installation  Septic Tank  
 Property Location: SR# 2045  Repairs  Nitrification Line

Subdivision Flossie B. Dow Lot # 2

Tax ID # \_\_\_\_\_ Quadrant # \_\_\_\_\_

Number of Bedrooms Proposed: 3 Lot Size: .89Ac

Basement with Plumbing:  Garage:

Water Supply:  Well  Public  Community

Distance From Well: 100 ft.

Following is the minimum specifications for sewage disposal system on above captioned property. Subject to final approval.

Type of system:  Conventional  Other \_\_\_\_\_

Size of tank: Septic Tank: 1000 gallons Pump Tank: \_\_\_\_\_ gallons

Subsurface Drainage Field No. of ditches 4 exact length of each ditch 75 ft. width of ditches 3 ft. depth of ditches 30 in.

French Drain Required: \_\_\_\_\_ Linear feet

Date: 3/28/2005

This permit is subject to revocation if site plans or intended use change.

Signed: Bryan McSwain R.S.  
 Environmental Health Specialist

\* Maintain all setbacks  
 \* Run ditches on contour

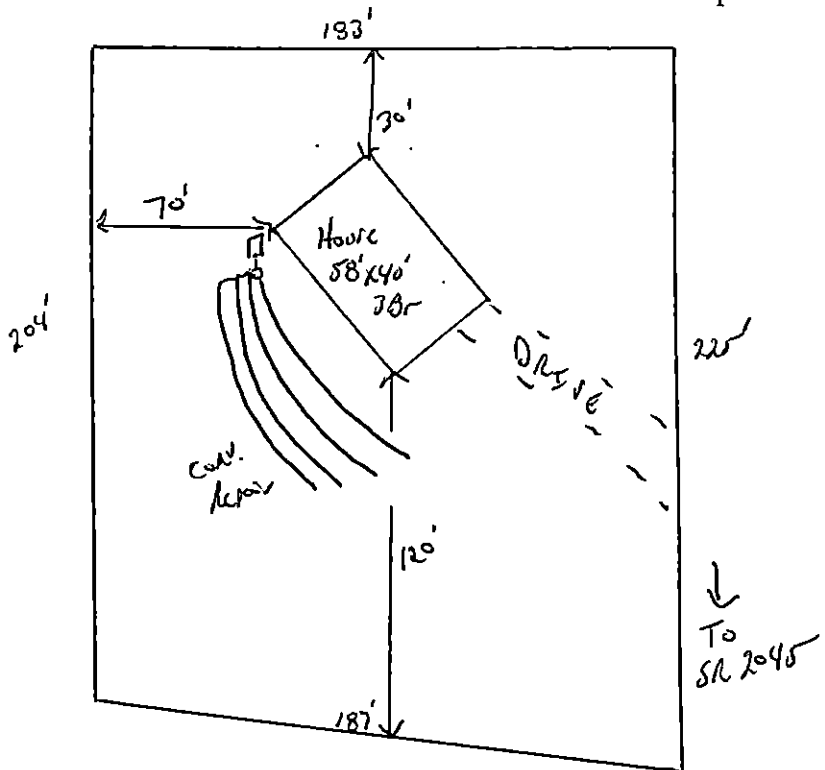

HARNETT COUNTY DEPARTMENT OF PUBLIC HEALTH  
AUTHORIZATION TO CONSTRUCT

Authorization is hereby given to construct a wastewater system to the specifications described by Harnett County Department of Public Health, Improvement Permit # 21723. This authorization shall be valid for a period not to exceed five (5) years from the date of issuance. *This authorization will be invalid if ownership, site plans, or intended use change.*

Homeworks Custom Builders 485-4111  
Name Telephone #

P.O. Box 64849 Fayetteville, N.C. 28306  
Address

2045 Elliott Bridge  
Property Location SR# Road Name

Flores B. Dow 2 3 .89Ac  
Subdivision Lot # # Bedrooms Proposed Lot Size

**TYPE OF SYSTEM**

New Installation  Repair  Septic Tank  Nitrification Lines

Conventional  Other \_\_\_\_\_

Basement  With Plumbing  Without Plumbing

Water Supply:  Well  Public Water Supply Minimum Well Setback: 100 Ft.

Septic Tank 1000 gal Pump Chamber \_\_\_\_\_ gal

**NITRIFICATION FIELD SPECIFICATIONS**

Number of fields 1 # of lines per field 4 Length of lines 75 Ft.

Width of ditches 3 ft. Depth of ditches 30 inches

French Drain: Linear feet required \_\_\_\_\_ Depth of gravel \_\_\_\_\_

No wastewater system shall be covered or placed into use by any person until an inspection by the Harnett County Health Department has determined that the system has been installed according to the conditions of the Improvement Permit and that a valid Operations Permit has been issued.

Bryan McSwain R.S.  
Signature of Authorized Agent for Harnett County

3/28/2005  
Date