

HTE 05-50011492 R

IMPROVEMENT PERMIT

21685

Be it ordained by the Harnett County Board of Health as follows: Section III, Item B. "No Person shall begin construction of any building at which a septic tank system is to be used for disposal of sewage without first obtaining a written permit from the Harnett County Health Department."

Name: (owner) RAYNOR BUILDERS INC
Property Location: SR# 1415 RAWLS CHURCH RD
New Installation, Septic Tank, Repairs, Nitrification Line

Subdivision ALEX PLACE Lot # 11

Tax ID # Quadrant #

Number of Bedrooms Proposed: 3 Lot Size: .58 AC

Basement with Plumbing: Garage:

Water Supply: Well, Public, Community

Distance From Well: 100 ft.

Following is the minimum specifications for sewage disposal system on above captioned property. Subject to final approval.

Type of system: Conventional, Other Pump To 25% REDUCTION SYSTEM

Size of tank: Septic Tank: 1000 gallons Pump Tank: 1000 gallons

Subsurface Drainage Field No. of ditches, exact length of each ditch, width of ditches, depth of ditches

French Drain Required: Linear feet

Date: 4/21/05

Signed: [Signature] Environmental Health Specialist

This permit is subject to revocation if site plans or intended use change.

REVISED 5/24/05 OT

- \* MAINTAIN ALL SETBACKS
\* PUMP SPECS 27gpm @ 15' TDH
\* MANATEE SPECS
2" SCH40 PIPE
2 3/4" SCH40 VALVES
2' PRESSURE HEAD
\* CALL WITH ANY QUESTIONS PRIOR TO INSTALLATION

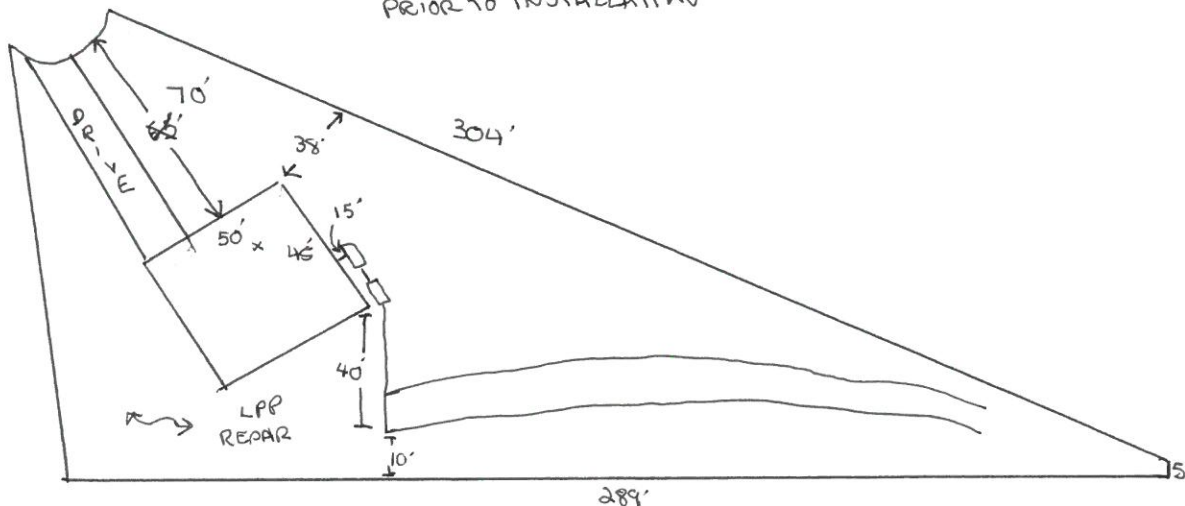

# HARNETT COUNTY DEPARTMENT OF PUBLIC HEALTH AUTHORIZATION TO CONSTRUCT

Authorization is hereby given to construct a wastewater system to the specifications described by Harnett County Department of Public Health, Improvement Permit # 21685. This authorization shall be valid for a period not to exceed five (5) years from the date of issuance. *This authorization will be invalid if ownership, site plans, or intended use change.*

RAYNOR BUILDERS 639-2011  
Name Telephone #

1281 JACKSON KING RD WILLOW SPRINGS NC 27592  
Address

1415 RAWLS CHURCH RD  
Property Location SR# Road Name

ALEX PLACE 11 3 .58  
Subdivision Lot # # Bedrooms Proposed Lot Size

### TYPE OF SYSTEM

New Installation  Repair  Septic Tank  Nitrification Lines

Conventional  Other PUMP TO 25% REDUCTION SYSTEM

Basement  With Plumbing  Without Plumbing

Water Supply:  Well  Public Water Supply Minimum Well Setback: 100 Ft.

Septic Tank 1000 gal Pump Chamber \_\_\_\_\_ gal

### NITRIFICATION FIELD SPECIFICATIONS

Number of fields 1 # of lines per field 2 Length of lines 150 Ft.

Width of ditches 3 ft. Depth of ditches 18-22 inches

French Drain: Linear feet required \_\_\_\_\_ Depth of gravel \_\_\_\_\_

No wastewater system shall be covered or placed into use by any person until an inspection by the Harnett County Health Department has determined that the system has been installed according to the conditions of the Improvement Permit and that a valid Operations Permit has been issued.

  
Signature of Authorized Agent for Harnett County

4/20/05 OT  
Date 5/24/05