

**SOIL/SITE EVALUATION
 for ON-SITE WASTEWATER SYSTEM**

Owner:

Applicant:

Address:

Date Evaluated:

Proposed Facility:

Design Flow (.1949):

Property Size:

Location of Site:

Property Recorded:

Water Supply: Public Individual Well

Spring Other

Evaluation Method: Auger Boring Pit

Cut

Type of Wastewater: Sewage Industrial Process

Mixed

P R O F I L E #	.1940 Landscape Position/ Slope%	Horizon Depth (IN.)	SOIL MORPHOLOGY .1941		OTHER PROFILE FACTORS				Profile Class & LTAR
			.1941 Structure/ Texture	.1941 Consistence Mineralogy	.1942 Soil Wetness/ Color	.1943 Soil Depth (IN.)	.1956 Sapro Class	.1944 Restr Horiz	
1	L	0-10	SL	FL CL NEMP					.3
		10-15	SCL	FL CL NESP					
		15-30	SC ^{CHY}	SL CL SCL SESP	30				
2	L	0-12	SL	FL CL NEMP					.3
		12-18	SCL	FL CL NESP					
		18-36	SC ^{CHY}	SL CL SCL SESP	32				

Description	Initial System	Repair System
Available Space (.1945)	/	/
System Type(s)	/	/
Site LTAR	.3	.3

Other Factors (.1946): _____
 Site Classification (.1948): _____
 Evaluated By: _____
 Others Present: _____

COMMENTS: _____

<u>LANDSCAPE POSITIONS</u>	<u>GROUP</u>	<u>TEXTURES</u>	<u>.1955 LTAR</u>	<u>CONSISTENCE MOIST</u>	<u>WET</u>
R-RIDGE	I	S-SAND	1.2 - 0.8	VFR-VERY FRIABLE	NS-NON-STICKY
S-SHOULDER SLOPE		LS-LOAMY SAND			
L-LINEAR SLOPE	II	SL-SANDY LOAM	0.8 - 0.6	FR-FRIABLE	SS-SLIGHTLY STICKY
FS-FOOT SLOPE		L-LOAM			
N-NOSE SLOPE	III	SI-SILT-	0.6 - 0.3	FI-FIRM	S-STICKY
H-HEAD SLOPE		SIL-SILT LOAM			
CC-CONCLAVE SLOPE	IV	CL-CLAY LOAM	0.4 - 0.1	VFI-VERY FIRM	VS-VERY STICKY
CV-CONVEX SLOPE		SIC-SILTY CLAY			
T-TERRACE		C-CLAY		EFI-EXTREMELY FIRM	NP-NON-PLASTIC
FP-FLOOD PLAN		SC-SANDY CLAY			SP-SLIGHTLY STICKY
					P-PLASTIC
					VP-VERY PLASTIC

STRUCTURE
 SG-SINGLE GRAIN
 M-MASSIVE
 CR-CRUMB
 GR-GRANULAR
 SBK-SUBANGULAR BLOCKY
 ABK-ANGULAR BLOCKY
 PL-PLATY
 PR-PRISMATIC

MINERALOGY
 SLIGHTLY EXPANSIVE
 EXPANSIVE

Show profile locations and other site features (dimensions, reference or benchmark, and North).

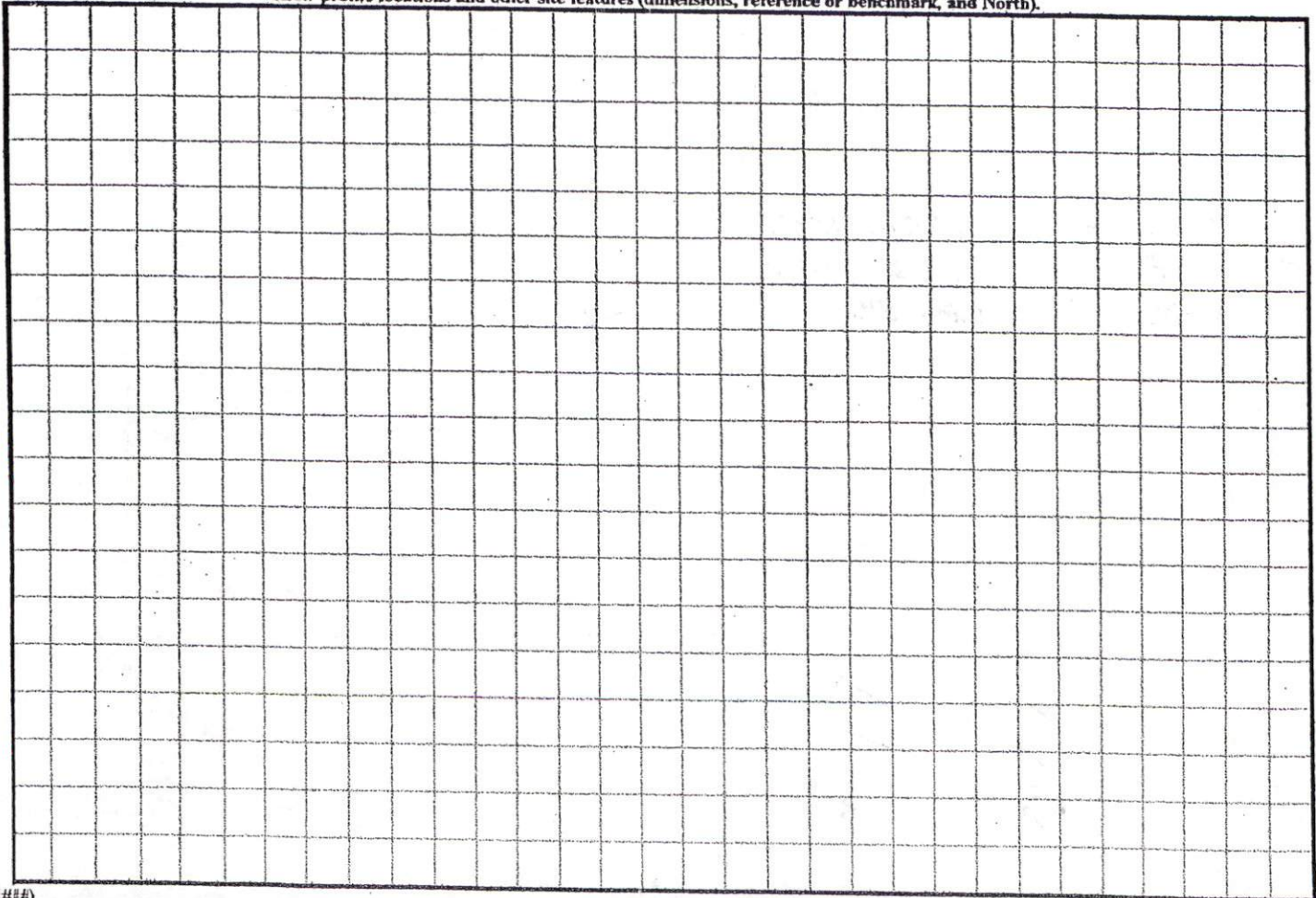

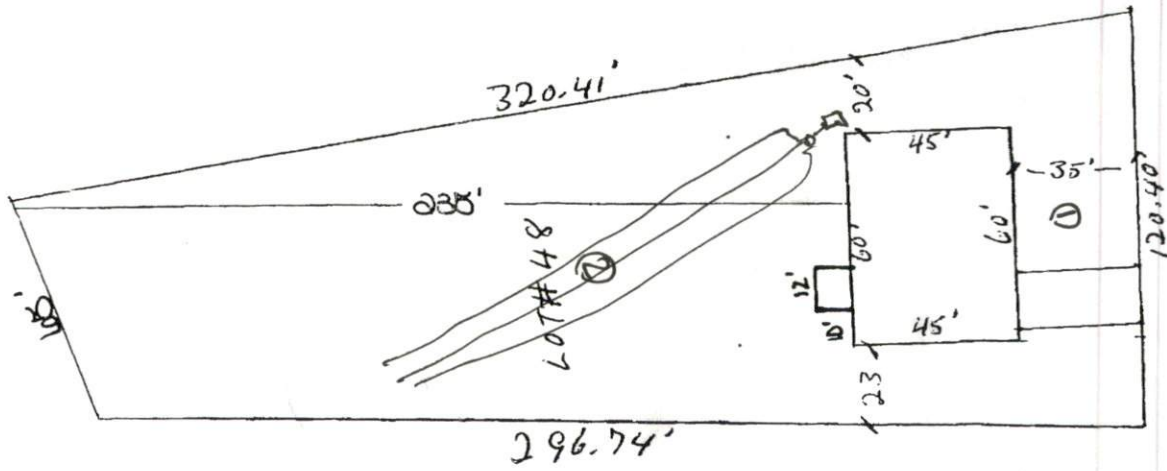

LOT # 49

296.74'

320.41'

105'

238'

LOT # 48

1" = 40'

TYLERSTONE DRIVE

SITE PLAN APPROVAL

DISTRICT RA30 USE SED

#BEDROOMS 3

DR/ARLINDA C. DUGGLES
Zoning Administrator

Date James R. Jackson 8-23-04

LOT # 47