

Application # 0650016213R

Harnett County Central Permitting  
PO Box 65 Lillington, NC 27546  
Telephone Number 910-893-7525 Fax 910-893-2793

**Application for Environmental Health Improvement Permit in Areas Zoned by Municipalities**

Land Owner Information:

Name: Carolyn Dorman  
Address: \_\_\_\_\_  
Phone: \_\_\_\_\_

Applicant Information:

Name: DJ Dalrymple  
Address: 91 Edna John Ct  
Dunn NC  
Phone: 919-630-0408

Property Location:

E911 Address: 91 Edna John Ct  
PIN or Parcel Number: 1507-38-5692.000 / 021537 0110 07  
Subdivision: Walt's Crossing Lot Number: 6  
State Road Number: \_\_\_\_\_ Lot Size: .63

Specific Directions to Job from Lillington: 421 towards Dunn Lt on Red Hill ch Rd  
Lt on Suggs Rt on Edna John Ct Lot on Lt

Proposed Use:

- ( ) Single Family Dwelling (Size: \_\_\_\_\_ x \_\_\_\_\_) # of Bedrooms: \_\_\_\_\_  
Basement: \_\_\_\_\_ Basement w/ Plumbing: \_\_\_\_\_ Deck: \_\_\_\_\_
- ( ) Multi Family Dwelling # of Units: \_\_\_\_\_ # of Bedrooms/Units: \_\_\_\_\_
- () Manufactured Home (Size: 28 x 60) # of Bedrooms: 3  
Garage: \_\_\_\_\_ Deck: \_\_\_\_\_
- () Number of Persons per Household 2 1/4 lot - per customer deal but  
Ext. Hood Susan sign off re customer  
would re-schedule. (CW)
- ( ) Business Square Footage Retail Space: \_\_\_\_\_ Type: \_\_\_\_\_
- ( ) Industry Square Footage: \_\_\_\_\_ Type: \_\_\_\_\_
- ( ) Home Occupation # of Rooms: \_\_\_\_\_ Use: \_\_\_\_\_
- ( ) Addition to Existing Building Size: \_\_\_\_\_ Use: \_\_\_\_\_
- ( ) Other: \_\_\_\_\_

Water Supply: ( ) County () Well ( ) Other  
Sewer: () New Septic Tank ( ) Existing Septic Tank ( ) Revision ( ) Sewer

**There is a \$250.00 charge for this service. This approval is subject to revocation if the intended use of the septic system changes or if false information is provided on this application.** Your signature below certifies all information above is correct.

Applicant Signature: Hebra Cardone Date: 11-17-06

8/06  
To Jim 11/5/07

Dalrymple  
91 Edna John Ct  
Brunn NC  
Watts Crossing

919-630-0408  
Lee Johnson

REVISION

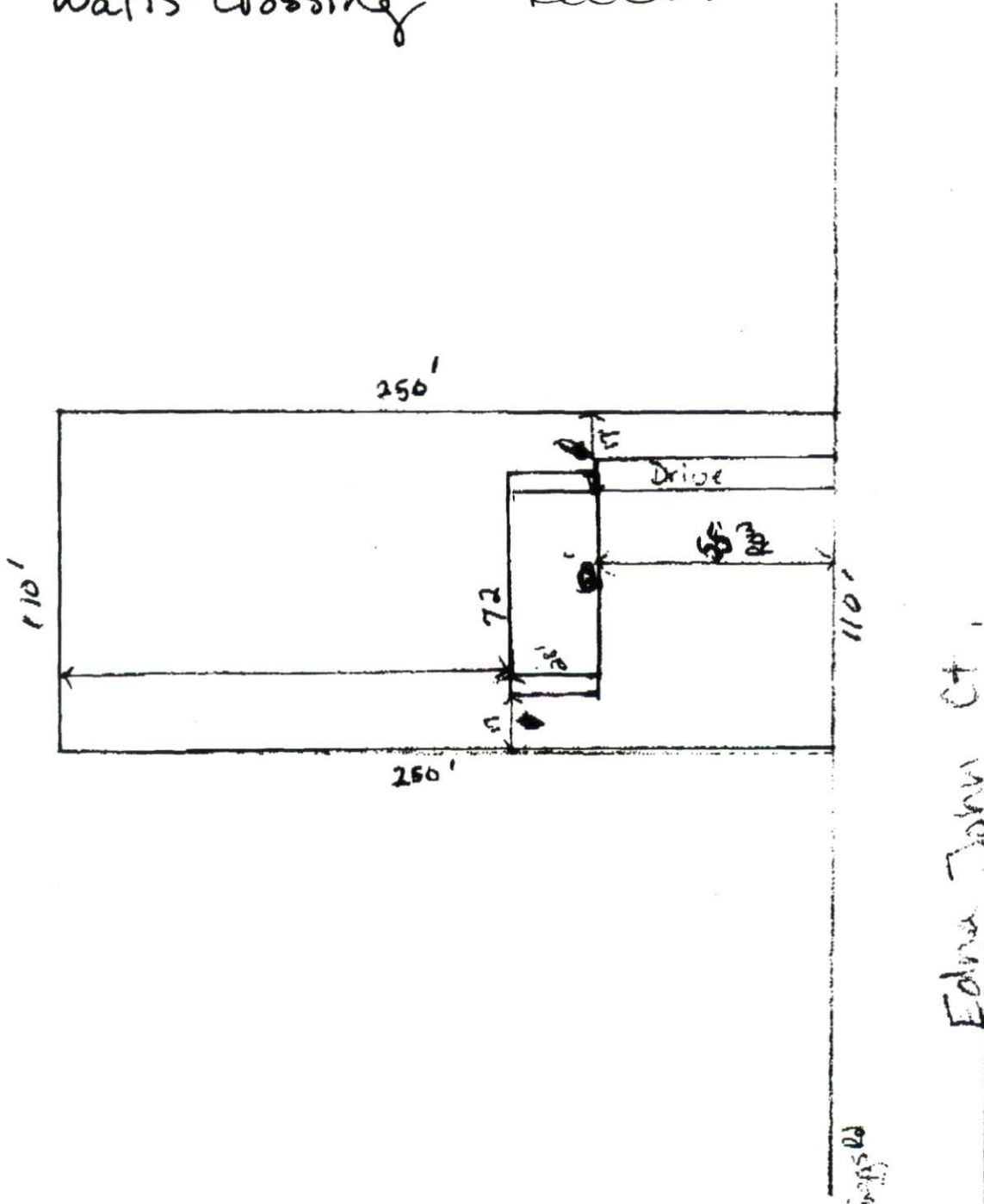

App#  
0650016213