

Preliminary Soils Evaluation

5845 Christian Light Road

~1.06 acres
Harnett County, NC

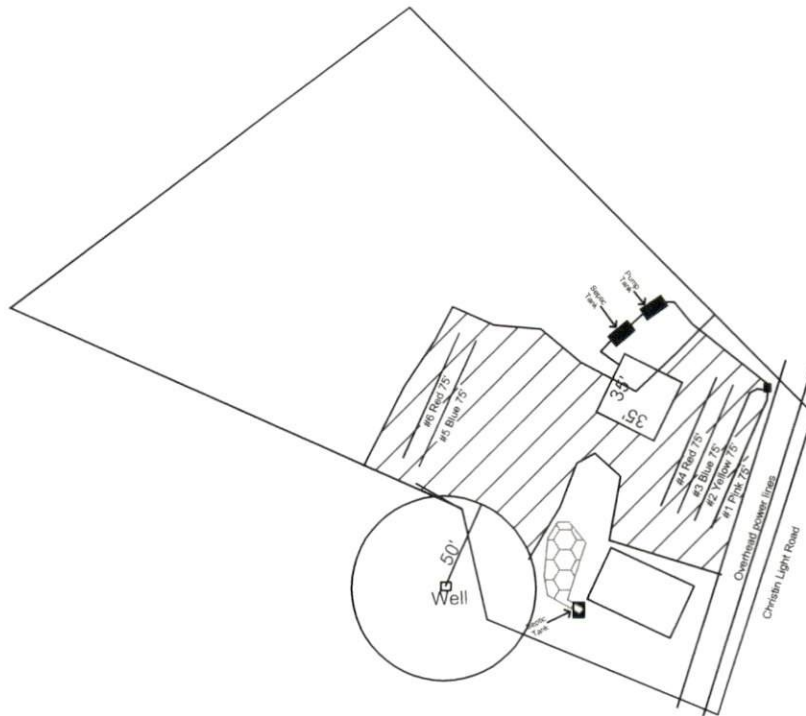

Proposed New 2-Bedroom Home

Existing 2-Bedroom Home

Existing System: Gravity
 Repair for Existing: Lines 5-6 (150')
 0.4 LTAR
 18-20" Trench Bottom
 Accepted Status System

New Primary System: Pump to D-Box
 Lines: 1-2 (150')
 0.4 LTAR
 18-20" Trench Bottom
 Accepted Status System
 New Repair System: Pump to D-Box
 Lines: 3-4 (150')
 0.4 LTAR
 18-20" Trench Bottom
 Accepted Status System

*Not a Survey
 (sketched from Harnett County GIS)

Legend

Areas contain soils with 30 inches or more of useable material and have potential for conventional, modified conventional, LPP or ultra-shallow conventional septic systems. There may be inclusion of soils 24-29 inches to a restrictive horizon that will have potential for LPP septic systems.

NE Areas Not Evaluated

GRAPHIC SCALE
 1" = 100'



Adams
 Soil Consulting
 919-414-6761
 Project #401

Preliminary Soils Evaluation

5845 Christian Light Road

~1.06 acres
Harnett County, NC



Proposed New 2-Bedroom Home

Existing 2-Bedroom Home

*Not a Survey
(sketched from Harnett County GIS)

Existing System: Gravity
Repair for Existing: Lines 5-6 (150')
0.4 LTAR
18-20" Trench Bottom
Accepted Status System

New Primary System: Pump to D-Box
Lines: 1-2 (150')
0.4 LTAR
18-20" Trench Bottom
Accepted Status System
New Repair System: Pump to D-Box
Lines: 3-4 (150')
0.4 LTAR
18-20" Trench Bottom
Accepted Status System

Legend

Areas contain soils with 30 inches or more of useable material and have potential for conventional, modified conventional, LPP or ultra-shallow conventional septic systems. There may be inclusion of soils 24-29 inches to a restrictive horizon that will have potential for LPP septic systems.

NE Areas Not Evaluated

GRAPHIC SCALE
1" = 100'



Adams
Soil Consulting
919-414-6761
Project #401

Preliminary Soils Evaluation

5845 Christian Light Road

~1.06 acres

Harnett County, NC

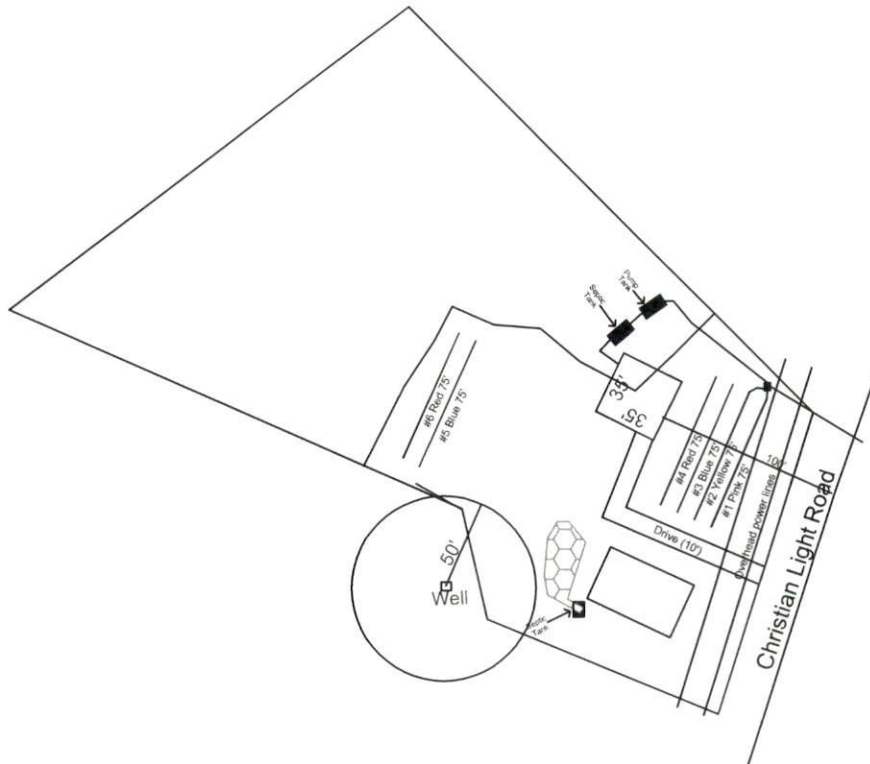

Proposed New 2-Bedroom Home

Existing 2-Bedroom Home

Existing System: Gravity
 Repair for Existing: Lines 5-6 (150')
 0.4 LTAR
 18-20" Trench Bottom
 Accepted Status System

New Primary System: Pump to D-Box
 Lines: 1-2 (150')
 0.4 LTAR
 18-20" Trench Bottom
 Accepted Status System
 New Repair System: Pump to D-Box
 Lines: 3-4 (150')
 0.4 LTAR
 18-20" Trench Bottom
 Accepted Status System

*Not a Survey
 (sketched from preliminary plat)

Legend

Areas contain soils with 30 inches or more of useable material and have potential for conventional, modified conventional, LPP or ultra-shallow conventional septic systems. There may be inclusion of soils 24-29 inches to a restrictive horizon that will have potential for LPP septic systems.

NE Areas Not Evaluated

GRAPHIC SCALE
 1" = 100'



Adams
 Soil Consulting
 919-414-6761
 Project #351