

OPERATIONS PERMIT

Name: (owner) Stephen Brasche New Installation Septic Tank
 Property Location: SR# 1128 Repairs Nitrification Line
 Subdivision Little River Plantation Lot # 108

TAX ID# _____ Quadrant # _____

Contractor: E. Sharpe Registration # _____

Basement with Plumbing: Garage:

Water Supply: Well Public Community

Distance From Well: 100 ft.

Following are the specifications for the sewage disposal system on above captioned property.

Type of system: Conventional Other _____

Size of tank: Septic Tank: 1000 gallons Pump Tank: _____ gallons

Subsurface Drainage Field No. of 5 exact length 80 width of 3 depth of 18
 ditches _____ of each ditch _____ ft. ditches _____ ft. ditches _____ in.

French Drain: _____ Linear feet

Date: 01-11-01

PERMIT NO. 16822

Inspected by: Joe Waters
 Environmental Health Specialist

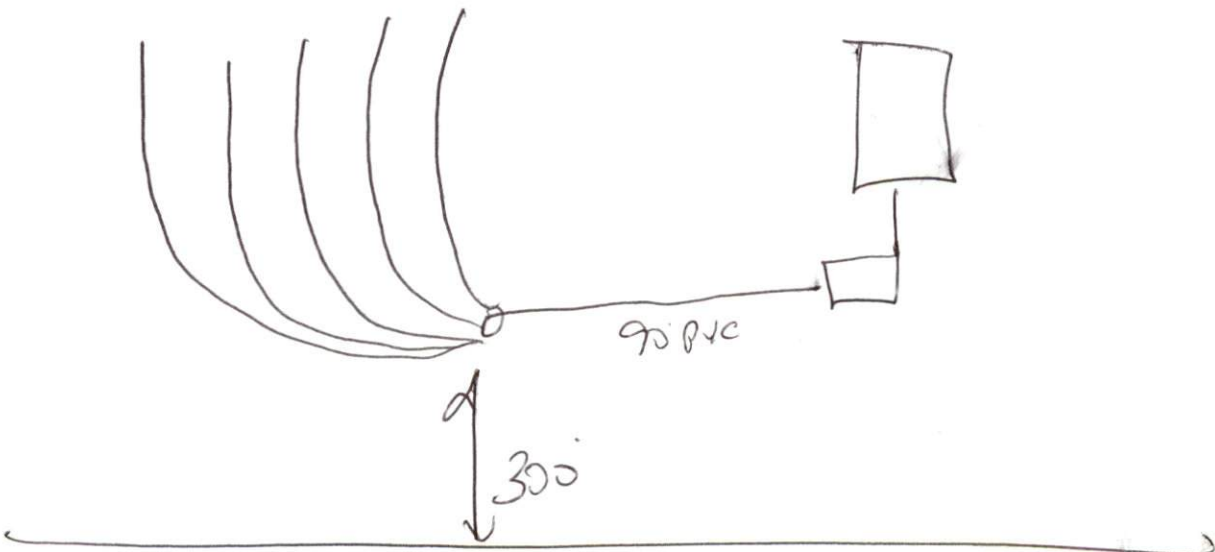

pu