

HTE # 05-50011278K

NETT COUNTY HEALTH DEPARTMENT  
ENVIRONMENTAL HEALTH SECTION

18189

# OPERATIONS PERMIT

Name: (owner) HEALING CENTER/ARXS INC  New Installation  Septic Tank  Repair

Property Location: SR# 2005 BRICK MILL RD  Nitrification Line  Expansion  
Subdivision OGBURN MEADOWS Lot # 3-4 Tax ID # \_\_\_\_\_ Quadrant # \_\_\_\_\_

Contractor: JEFF THOMPSON Registration # \_\_\_\_\_

Basement with Plumbing:  Garage:

Water Supply:  Well  Public  Community  
Distance From Well: \_\_\_\_\_ ft.

Following are the specifications for the sewage disposal system on above captioned property.

Type of system:  Conventional  Other Flow Equalization System (GRAVEL)  
M.H.S.-3TB 653-2000      M.I.L.S. 3500 PT 225 7-8-05

Size of tank: Septic Tank: 2000 gallons Pump Tank: 3500 gallons

Subsurface Drainage Field: No. of ditches 3 exact length of each ditch 101 ft. width of ditches 3 ft. depth of ditches 24 in.

French Drain Required: \_\_\_\_\_ Linear feet Date: 3/23/06

PERMIT NO. 22061 Inspected by: [Signature]

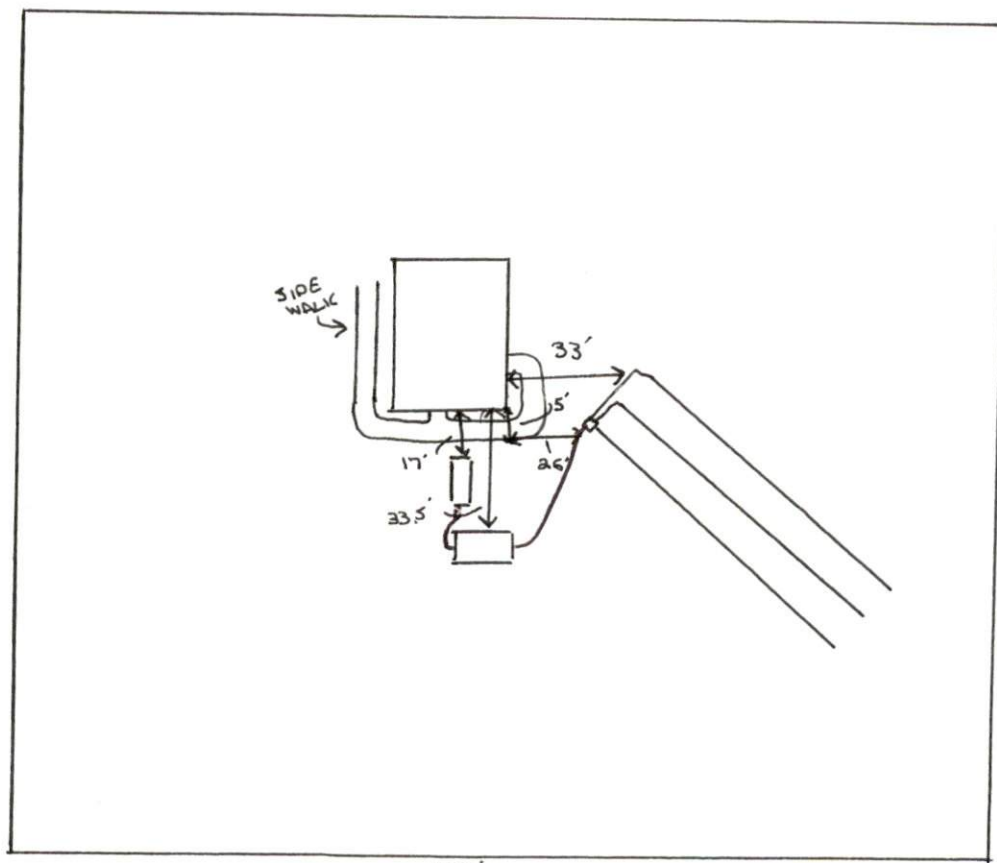

\*LINE & TANKS CHECKED ON 1/26/06 BY OT  
\*TIMER SET ON 3/23/06