

NAME Robert Yost
 Address 1434 Atkins Rd
Fuquay Varina NC 27526

Application # 42654

* for 8' x 12' deck extension

Steps front view

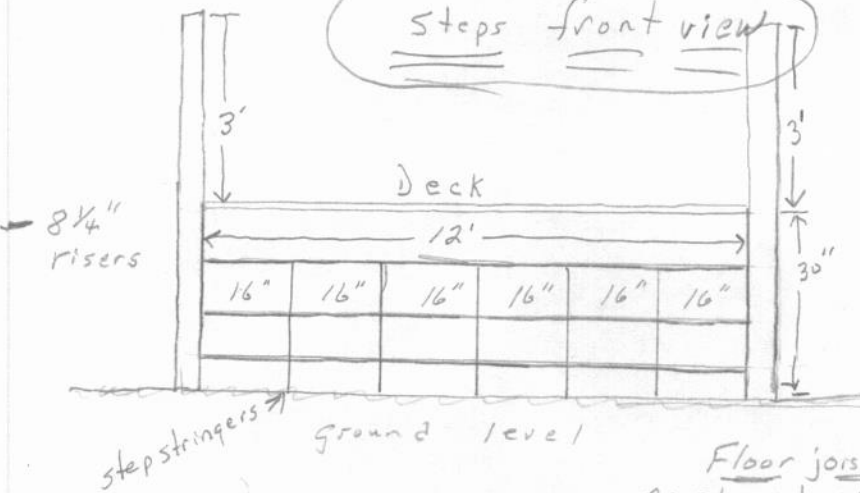

* decking - 5/4 x 6 x 12' { Anchored with 2 1/2" deck screws
 * Corners tied in with { galvanized 3/8 x 4" lags
 3/8 x 6" lags deck screws

Floor joists
 Anchored with hangers + deck screws

Top View

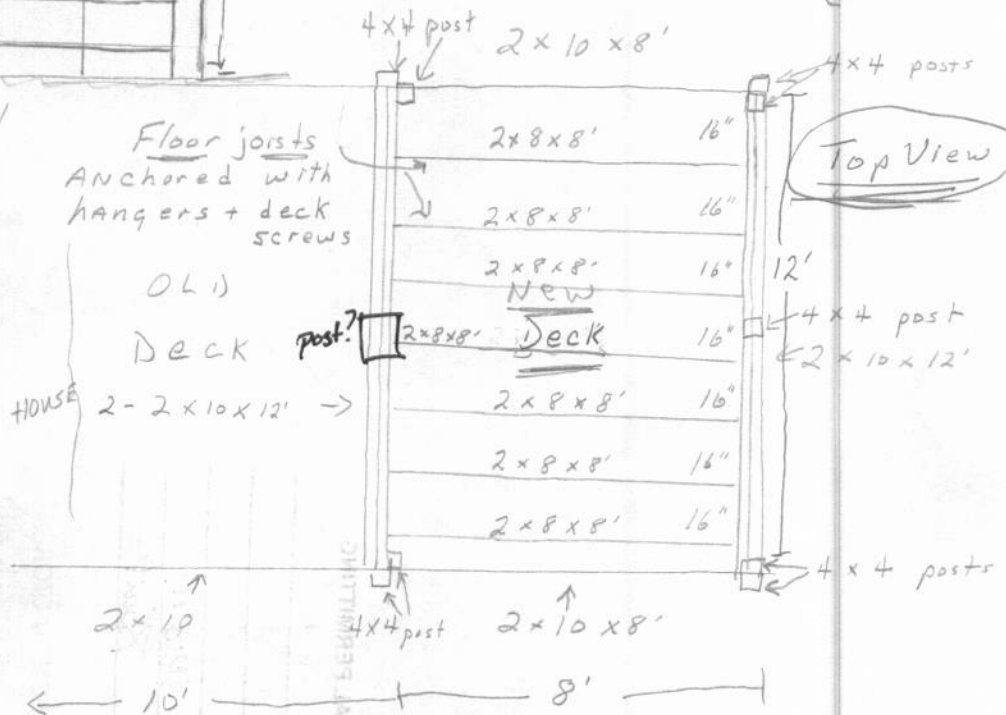

Step rails

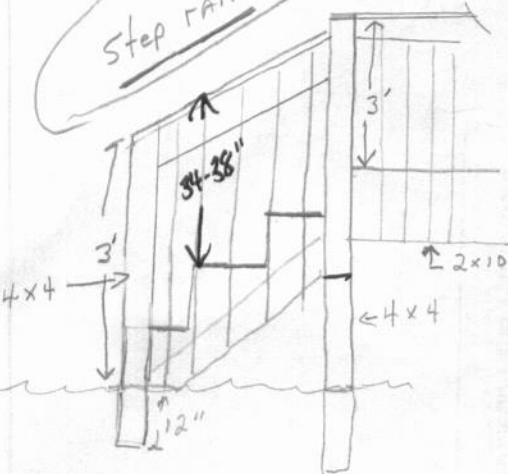

Side View

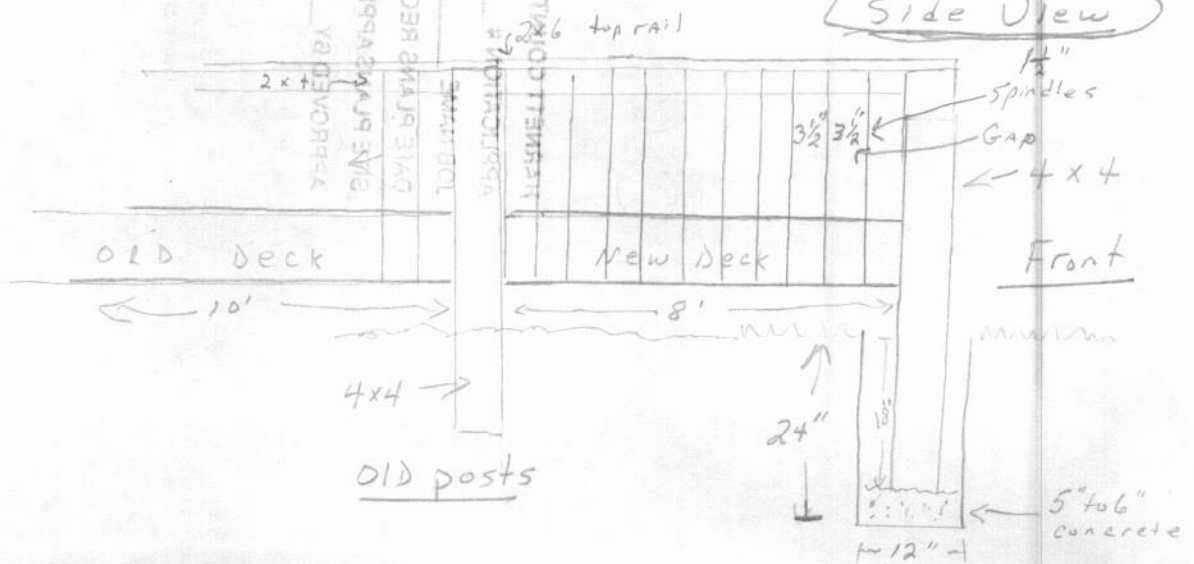

NEW posts

Deck addition

HARNETT COUNTY CENTRAL PERMITTING

APPLICATION # 17 50042654

JOB NAME UCS

DATE PLANS RECEIVED 10.31.17

SITE PLANS APPROVED 10.31.17

APPROVED BY Brett

NOTICE TO CONTRACTOR

All construction must comply with
current NC Building Codes and is subject
to field inspection and verification.

APPENDIX M WOOD DECKS

*This appendix is a North Carolina addition to the 2009 International Residential Code. There will be no underlined text.
(The provisions contained in this appendix are adopted as part of this code.)*

SECTION AM101 GENERAL

AM101.1 General. A deck is an exposed exterior wood floor structure which may be attached to the structure or freestanding. Roofed porches (open or screened-in) may be constructed using these provisions.

AM101.2 Deck design. Computer deck design programs may be accepted by the code enforcement official.

SECTION AM102 FOOTERS

AM102.1 Footers. Support post shall be supported by a minimum footing per Figure AM102 and Table AM102.1. Minimum footing depth shall be 12-inches below finished grade per Section R403.1.4. Tributary area is calculated per Figure AM102.1.

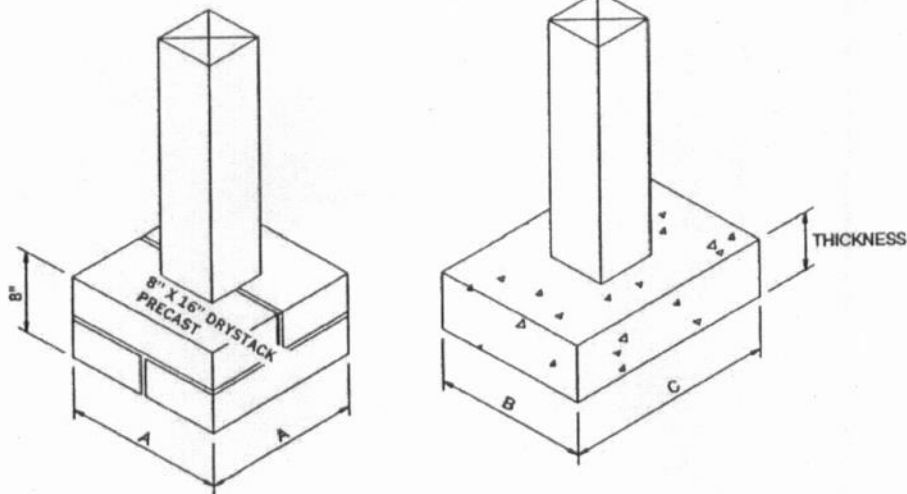

FIGURE AM102

TABLE AM102.1
FOOTING TABLE^{a,b,c}

SIZE (inches)		TRIBUTARY AREA (sq. ft.)	THICKNESS (inches)	
A x A	B x C		Precast	Cast-in-Place
8 x 16	8 x 16	36	4	6
12 x 12	12 x 12	40	4	6
16 x 16	16 x 16	70	8	8
—	16 x 24	100	—	8
—	24 x 24	150	—	8

For SI: 1 inch = 25.4 mm, 1 square foot = 0.0929 m².

- a. Footing values are based on single floor and roof loads
- b. Support post must rest in center 1/3 of footer
- c. Top of footer shall be level for full bearing support of post

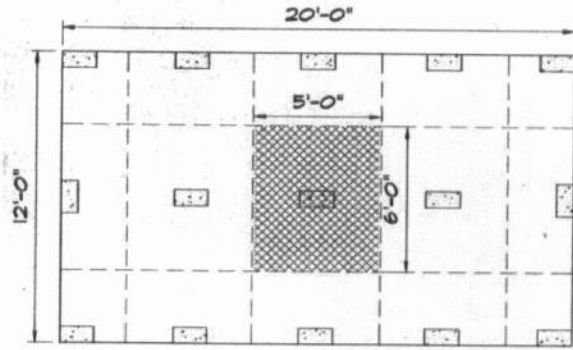

Note: Tributary area of shaded section on free standing deck shown is 5' x 6' = 30 sq. ft. Code will require a minimum footer of 8" x 16" per Table AM102.1.

FIGURE AM102.1

**SECTION AM104
DECK ATTACHMENT**

AM104.1 Deck attachment. When a deck is supported at the structure by attaching the deck to the structure, the following attachment schedules shall apply for attaching the deck band to the structure.

AM104.1.1 All structures except brick veneer structures.

FASTENERS	8' MAX JOIST SPAN ^a	16' MAX JOIST SPAN ^a
⁵ / ₈ " Hot dipped galv. bolts with nut and washer ^b	1 @ 3'-6" o.c.	1 @ 1'-8" o.c.
and	and	and
12d Common hot dipped galv. nails ^c	2 @ 8" o.c.	3 @ 6" o.c.

- a. Attachment interpolation between 8 foot and 16 foot joists span is allowed.
- b. Minimum edge distance for bolts is 2 1/2 inches.
- c. Nails must penetrate the supporting structure band a minimum of 1 1/2 inches.

AM104.1.2 Brick veneer structures.

FASTENERS	8' MAX JOIST SPAN ^a	16' MAX JOIST SPAN ^a
⁵ / ₈ " Hot dipped galv. bolts with nut and washer ^b	1 @ 2'-4" o.c.	1 @ 1'-4" o.c.

- a. Attachment interpolation between 8 foot and 16 foot joist span is allowed.
- b. Minimum edge distance for bolts is 2 1/2 inches.

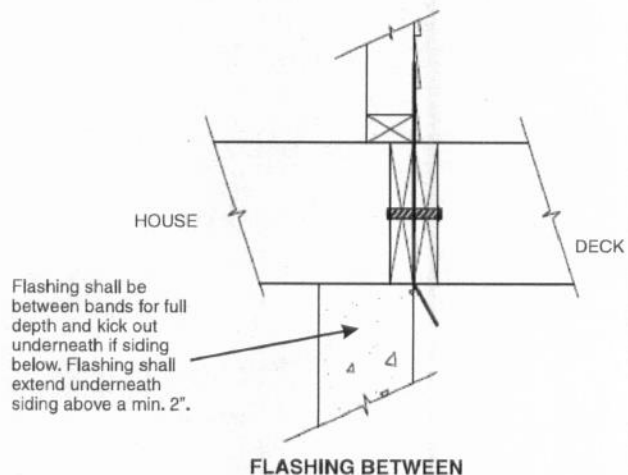
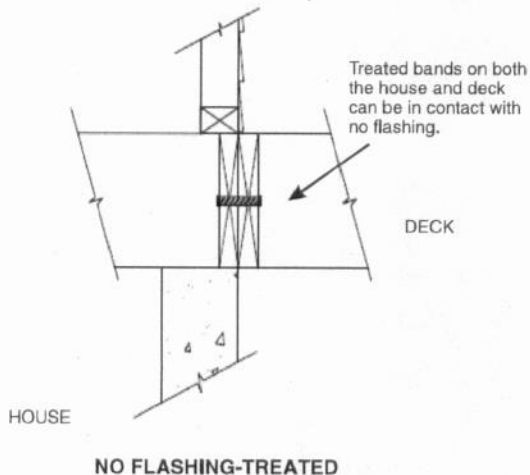

FIGURE AM103

AM104.1.3 Masonry ledge support. If the deck band is supported by a minimum of 1/2 inch masonry ledge along the foundation wall, 5/8 inch hot dipped galvanized bolts with washers spaced at 48 inches o.c. may be used for support.

AM104.1.4 Other means of support. Joist hangers or other means of attachment may be connected to house band and shall be properly flashed.

**SECTION AM105
GIRDER SUPPORT AND SPAN**

AM105.1 Girder support and span. Girders shall bear directly on support post with post attached at top to prevent lateral displacement or be connected to the side of posts with two 5/8 inch hot dipped galvanized bolts with nut and washer. Girder spans are per Tables R502.5(1) and (2). Girder support may be installed per Figure AM105 for top mount; Figure AM105.1 for side mount and Figure AM105.2 for split girder detail. Girders may also be cantilevered off ends of support post no more than 1 joist spacing or 16 inches, whichever is greater per Figure AM105.3.

**SECTION AM106
JOIST SPANS AND CANTILEVERS**

AM106.1 Joist spans and cantilevers. Joists spans shall be based upon Table R502.3.1(2) with 40 lbs per sq. ft. live load and 10 lbs per sq. ft. dead load. Floor joists for exterior decks may be cantilevered per Table R502.3.3 (1).

SPACING	2 x 6	2 x 8	2 x 10	2 x 12
12 inches	10-9	14-2	18-0	21-9
16 inches	9-9	12-10	16-1	18-10
19.2 inches	9-2	12-1	14-8	17-2
24 inches	8-6	11-0	13-1	15-5

Partial reprint of Table R502.3.1(2), #2 SYP only joist spans (ft-in)

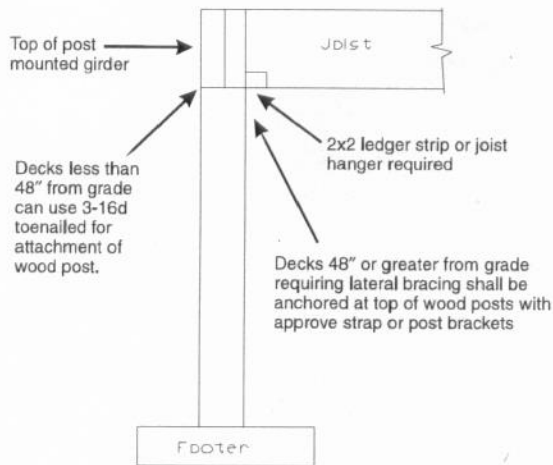

**TOP MOUNT/FLUSH
FIGURE AM105**

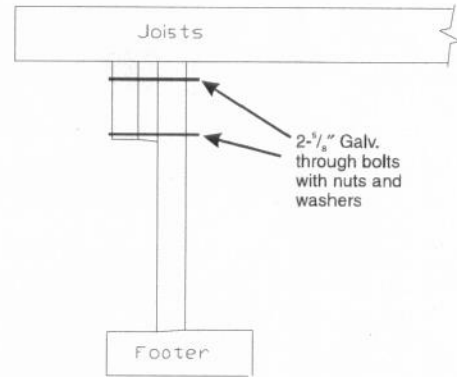

**SIDE MOUNT DROPPED GIRDER
FIGURE AM105.1**

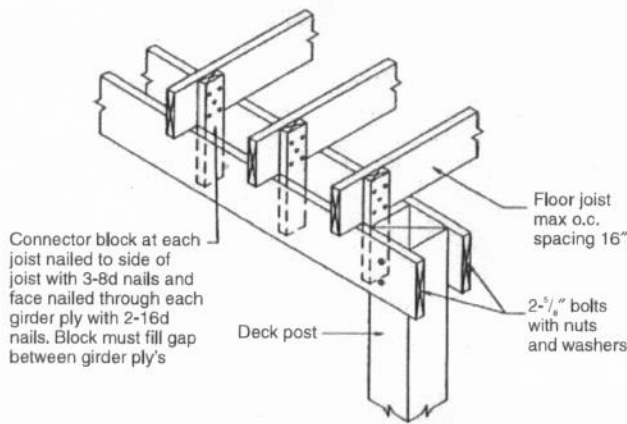

Split girder limited to floor loads only and cantilever girder ends allowed per AM105.3

**SPLIT GIRDER DETAIL
FIGURE AM105.2**

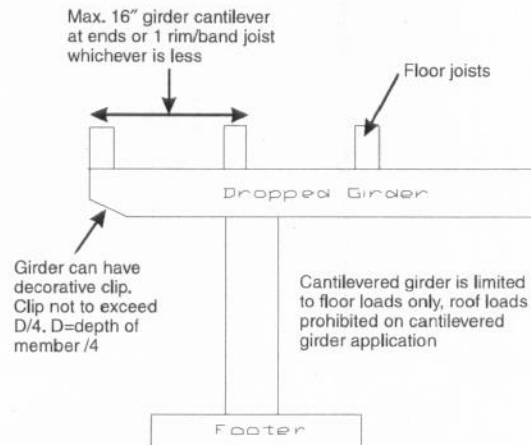

**CANTILEVERED DROPPED GIRDER DETAIL
FIGURE AM105.3**

**SECTION AM107
FLOOR DECKING**

AM107.1 Floor decking. Floor decking shall be No. 2 grade treated Southern Pine or equivalent. The minimum floor decking thickness shall be as follows:

SPACING	DECKING (nominal)
12" o.c	1" S4S
16" o.c.	1" T&G
19.2" o.c.	1 1/4" S4S
24"-36" o.c.	2" S4S

**SECTION AM108
POST HEIGHT**

AM108.1 Post height. Maximum height of deck support posts as follows:

Post size ^a	Max. Post Height ^{b,c}
4x4	8'-0"
6x6	20'-0"

a. This table is based on No. 2 Southern Pine posts.

b. From top of footing to bottom of girder.

c. Decks with post heights exceeding these requirements shall be designed by a registered design professional.

**SECTION AM109
DECK BRACING**

AM109.1 Deck bracing. Decks shall be braced to provide lateral stability. The following are acceptable means to provide lateral stability.

AM109.1.1. When the deck floor height is less than 4'-0" above finished grade per Figure AM109 and the deck is attached to the structure in accordance with Section AM104, lateral bracing is not required.

AM109.1.2. 4x4 wood knee braces may be provided on each column in both directions. The knee braces shall attach to each post at a point not less than 1/3 of the post length from the top of the post, and the braces shall be angled between 45 degrees and 60 degrees from the horizontal. Knee braces shall be bolted to the post and the girder/double band with one 5/8 inch hot dipped galvanized bolt with nut and washer at both ends of the brace per Figure AM109.1

AM109.1.3. For freestanding decks without knee braces or diagonal bracing, lateral stability may be provided by embedding the post in accordance with Figure AM109.2 and the following:

POST SIZE	MAXIMUM TRIBUTARY AREA	MAXIMUM POST HEIGHT	EMBEDMENT DEPTH	CONCRETE DIAMETER
4x4	48 SF	4'-0"	2'-6"	1'-0"
6x6	120 SF	6'-0"	3'-6"	1'-8"

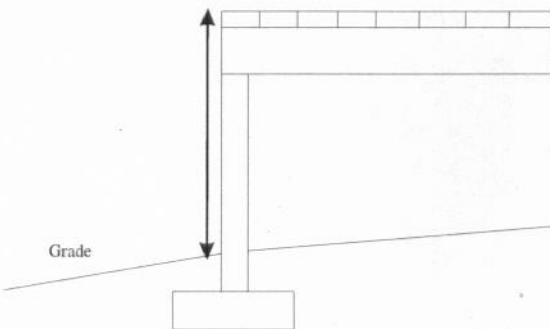

Less than 4' (decking to grade) and attached to structure no bracing required

FIGURE AM109

AM109.1.4. 2x6 diagonal vertical cross bracing may be provided in two perpendicular directions for freestanding decks or parallel to the structure at the exterior column line for attached decks. The 2x6's shall be attached to the posts with one 5/8 inch hot dipped galvanized bolt with nut and washer at each end of each bracing member per Figure AM109.3.

AM109.1.5. For embedment of piles in Coastal Regions, see Chapter 45.

Freestanding decks requiring bracing shall be installed in both directions off each post

Decks attached to structure require diagonal bracing only at outside girder line parallel with structure

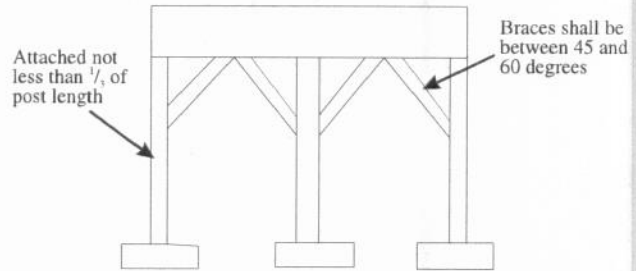

FIGURE AM109.1

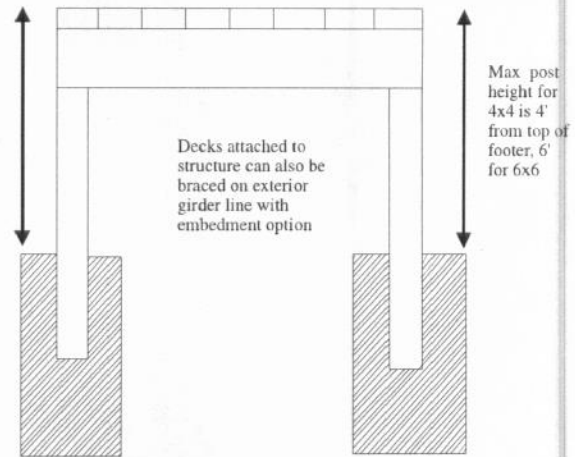

FIGURE AM109.2

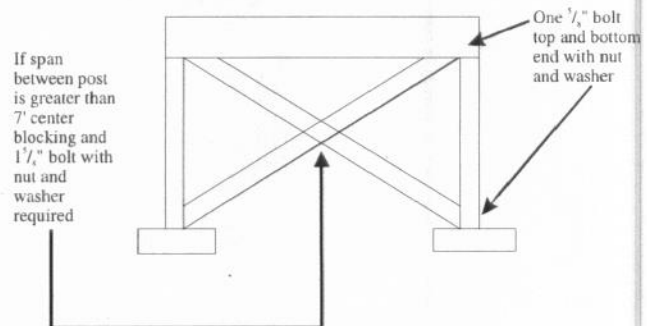

FIGURE AM109.3

**SECTION AM110
STAIRS**

AM110.1 Stairs shall be constructed per Figure AM110. Stringer spans shall be no greater than 7 foot span between supports. Spacing between stringers shall be based upon decking material used per AM107.1. Each Stringer shall have minimum 3 1/2 inches between step cut and back of stringer. If used, suspended headers shall be attached with 3/8 inch galvanized bolts with nuts and washers to securely support stringers at the top.

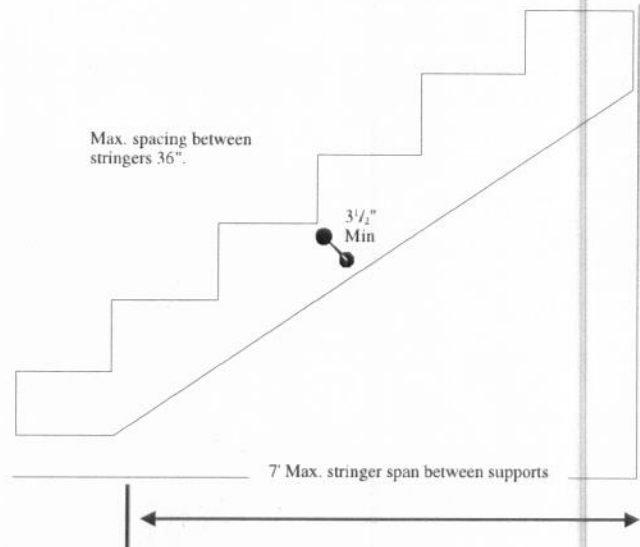
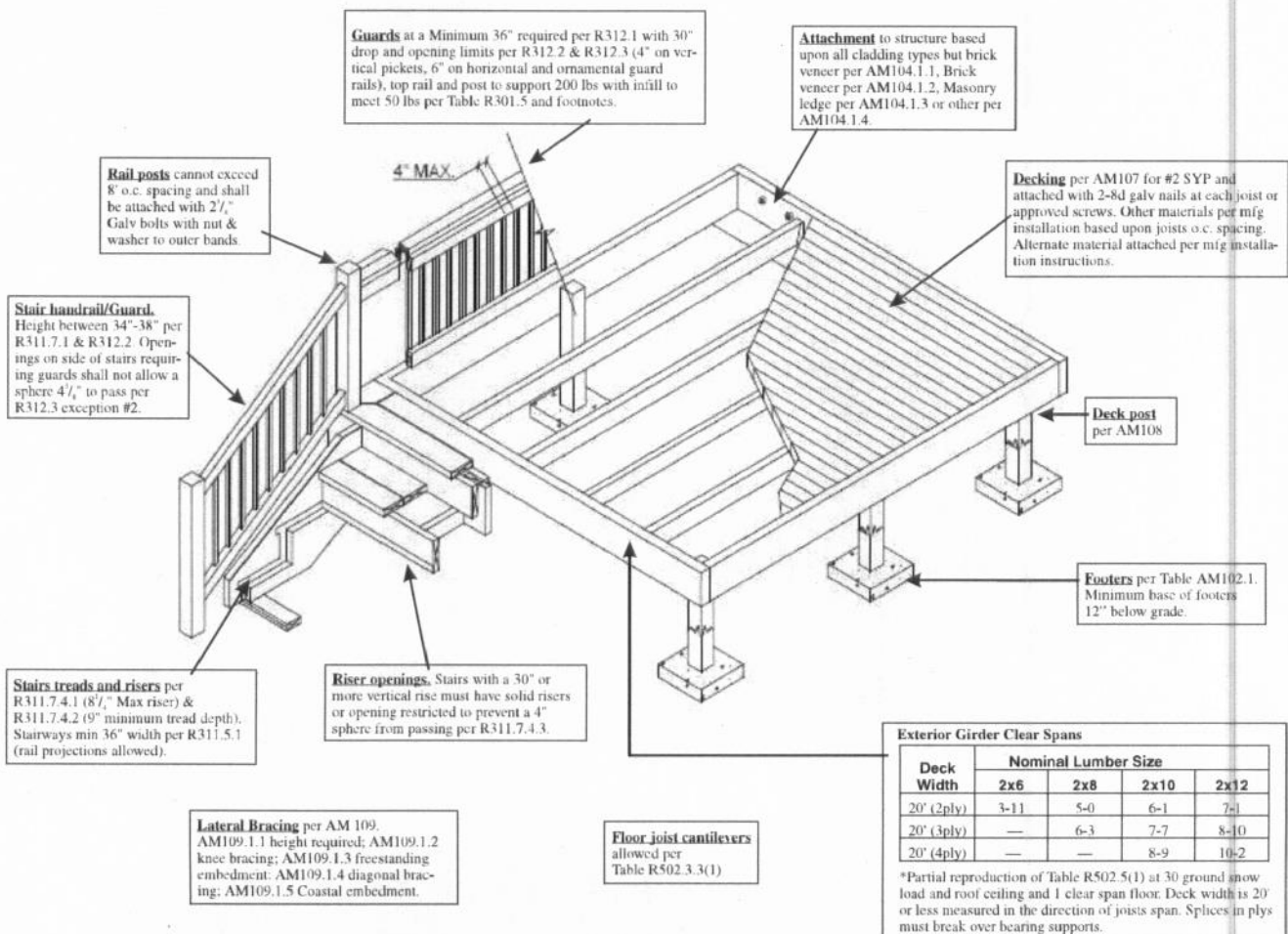

FIGURE AM110

**SECTION AM111
HANDRAILS, GUARDS AND GENERAL**

AM111.1 Handrails, guards and general. Deck handrails, guards and general construction shall be per Figure AM111.



Deck Width	Nominal Lumber Size			
	2x6	2x8	2x10	2x12
20' (2ply)	3-11	5-0	6-1	7-1
20' (3ply)	—	6-3	7-7	8-10
20' (4ply)	—	—	8-9	10-2

*Partial reproduction of Table R502.5(1) at 30 ground snow load and roof ceiling and 1 clear span floor. Deck width is 20' or less measured in the direction of joist span. Splices in ply must break over bearing supports.

FIGURE AM111

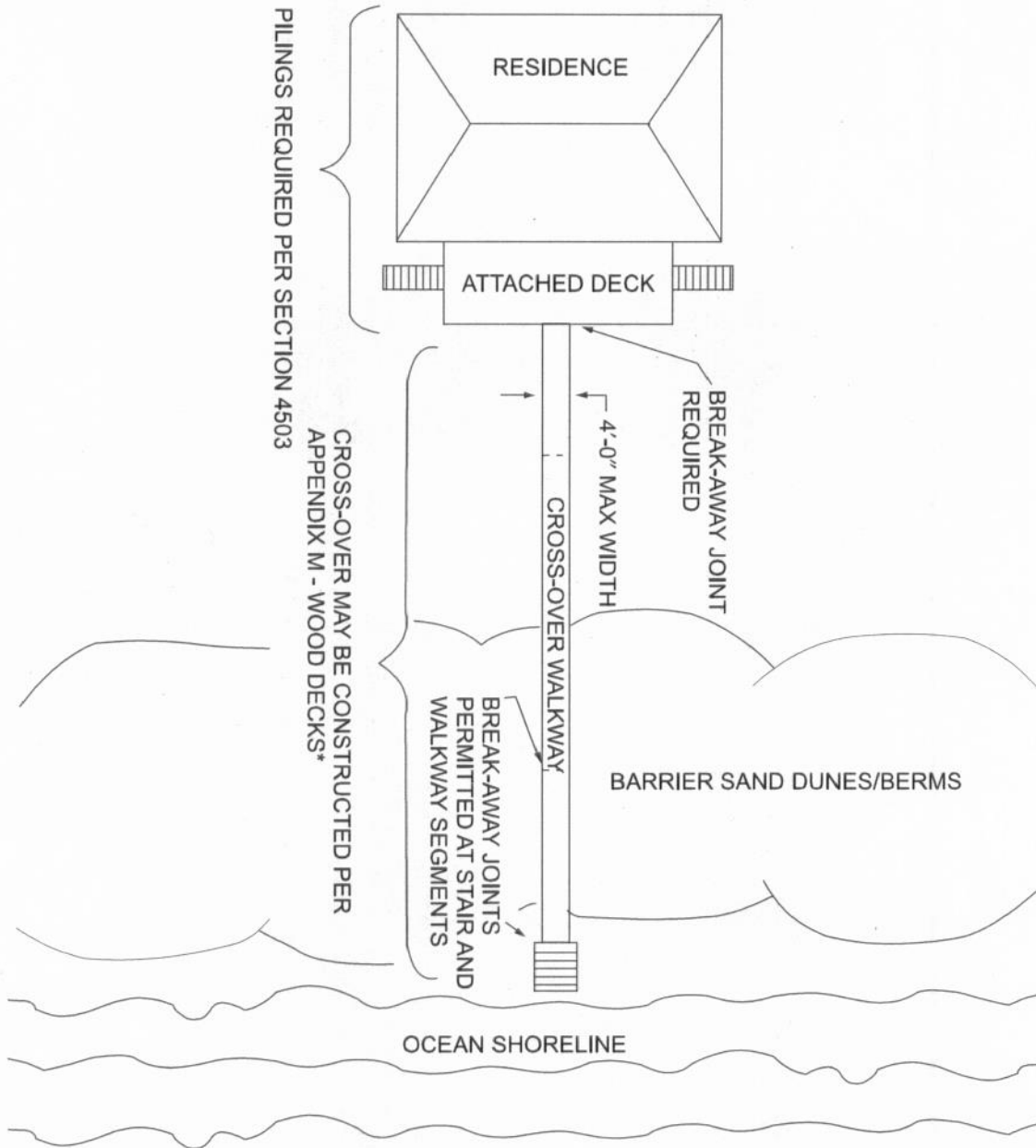

**FIGURE AM112
WALKWAYS OVER DUNES OR BERMS IN OCEAN HAZARD AREAS**

For SI: 1 inch = 25.4, 1 foot = 304.8 mm.

* Posts for walkways over dunes or berms shall be embedded a minimum depth of 4'-0" and post heights shall be limited to 5'-0" above grade for 4 x 4 and 10'-0" above grade for 6 x 6. Walkways or portions of walkways over 4'-0" in width shall comply with the requirements of Chapters 45 and 46. Maximum walkway surface height is 30" above grade without guard rails.

** Walkway stair runs can be greater than 12' without a landing.

