



Fire Marshal Division

P.O. Box 370
Lillington, NC 27546
910-893-7580

*Full Alarm
Plans*

Application for Plan Review

Application # 18-50043022

Date Received: 6.15.18 Received By: djdwsm

Name of Project: Overhills H.S. Dining Expansion - Harnett Co. Schools

Physical Address of Project: 2495 Ray Road
Spring Lake NC NC.

Plans Submitted By: Jim Carroll / E.E.S.

Project Phone: (919) - 359 - 2239

Contact Person/Address: 3821 Pawhatan Rd
Clayton, N.C. 27520

Contact Phone: (919) - 359 - 2239 () -

Contractor's Name/Info: Edwards Electronic Systems

Contractor's Phone: (919) - 359 - 2239

- Plans that are submitted will be reviewed as quickly as possible with an average time of review between 7-10 working days.
- Status checks may be conducted on plan reviews by visiting the website <http://hteweb.harnett.org/Click2GovBP/Index.jsp> or by calling the Harnett County Central Permitting Office (910-893-4759), or the Harnett County Fire Marshal's Office (910-893-7580).
- Approved plans must be picked up from the Central Permitting Office and all fees paid before any required inspections can be conducted.

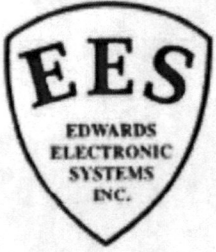

3821 Powhatan Rd. Clayton, NC 27520
P.O. Box 39 Clayton, NC 27528
Phone (919) 359-2239
Fax (919) 359-2913

Edwards Electronic Systems, Inc.

**Overhills High School
Dining Expansion
2495 Ray Road**

Spring Lake, North Carolina

FIRE ALARM SYSTEM SUBMITTAL

06/13/2018



Date: 05/15/18
 Version: QSP_120_e1_AI v7
 Job No: 0

Job Name: Overhills High School Dinning Addition
 Filename: Parts and Smarts Fire Alarm Proposal

To: Contractor

Attn: Estimating Department

Qty	Cat No	Description
SuperDuct Signature Smoke Detector		
1	SIGA-SD	SuperDuct Detector
SuperDuct Sampling Tubes		
1	SD-T78	SuperDuct, Air sample tube, 78 inch
SuperDuct Remote Test Stations		
1	SD-TRK	SuperDuct, Remote test/reset station, keyed
Signature Series Life Safety Modules		
Manual Pull Stations		
2	SIGA-278	Double Action Fire Alarm Station
Genesis Temporal Fire Horn-Strobes, Wall Mount, 84.4/79.4 dBA , Multi-candela, 1 Gang		
4	G1F-HDVM	Horn-Strobe, running man, white, "FIRE", 15, 30, 75, 110 cd
Genesis Outdoor Rated Horn-Strobes, Wall/Ceiling Mount, Standard Candela		
1	WG4RF-HVMC	Outdoor rated horn-strobe, red with FIRE marking, clear lens
Genesis Outdoor Rated Accessories		
1	WG4RTS	Surface skirt, red, for Genesis WG4 horn or horn-strobe
1	74347U	Surface mount box, 4" square, outdoor rated, red
Custom Additions		
1	1 Lot	Installation of Devices and Wire if turn key bid accepted.
1	1 Lot	Programming and Certification
1	1 Lot	Shop Drawings and Submittals
1	1 Lot	Freight and Tax
1	1 Year	Warranty Parts and Labor
1	Note:	All 120VAC and raceway will be supplied by the E.C. if turnkey
1	Custom 9	proposal accepted.
1	Note:	Permits to be supplied by the E.C.



Intelligent Duct Smoke Detector

SIGA-SD

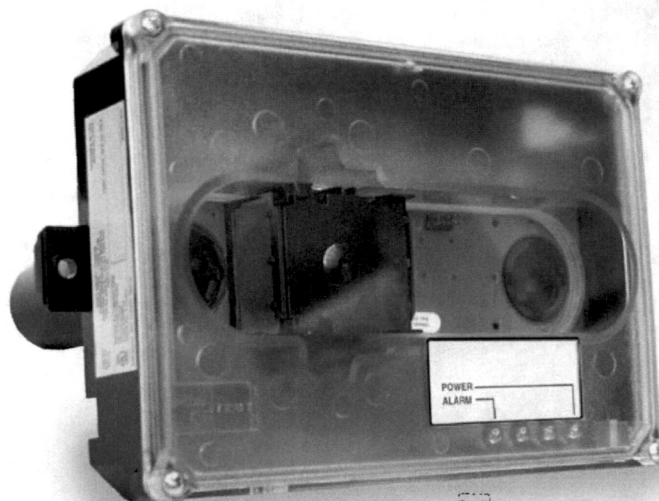

Overview

The Edwards *SuperDuct* Signature Series smoke detector is the most advanced and most reliable device in its class. Designed for easy installation and superb reliability, *SuperDuct* represents the perfect balance of practical design and advanced technology.

SuperDuct detectors feature a unique design that speeds installation and simplifies maintenance. Removable dust filters, conformally coated circuit boards, and optional water-resistant gaskets keep contaminants away from components, ensuring years of trouble-free service. When cleaning is required, the assemblies come apart easily and snap back together in seconds.

A **Signature Series photoelectric sensor** is incorporated into the design of each SIGA-SD duct smoke detector. This sensor inherits the power and benefits of this exceptional line of intelligent devices.

Signature Series sensors gather analog information from their smoke sensing elements and convert it into digital signals. The sensor measures and analyses these signals and compares the information to historical readings and time patterns to make an alarm decision. Digital filters remove signal patterns that are not typical of fires, which virtually eliminates unwanted alarms.

WARNING: Duct detectors have specific limitations. Duct detectors are not a substitute for an open area smoke detector. Duct detectors are not a substitute for early warning detection or a replacement for a building's regular fire detection system. Smoke detectors are not designed to detect toxic gases which can build up to hazardous levels in some fires. These devices will not operate without electrical power. As fires frequently cause power interruptions, Edwards suggests you discuss further safeguards with your local fire protection specialist.

Standard Features

- Less than 2" deep for easy installation and applications where space is tight
- -4°F to 158°F (-20°C to 70°C) operating range with 100 ft/min. to 4,000 ft/min air velocity rating assures reliability under harsh environmental conditions
- Status LEDs remain visible through clear assembly cover
- Cover monitor switch for added security
- Standard sampling tube spacing for easy drop-in migration from other detectors
- Sampling tube can be installed with or without the cover in place and can be rotated in 45-degree increments to ensure proper alignment with duct airflow
- 15.2 to 19.95 Vdc operation
- Magnet-activated test switch
- One Form C auxiliary alarm relay for controlling ancillary equipment (e.g., HVAC controls)
- No special tools required for easy access to field connections
- Signature Series intelligence
- Environmental compensation with differential sensing for reliable, stable, and drift-free sensitivity
- Wide 0.79% to 2.46% obscuration/ft. smoke sensitivity
- Identification of dirty or defective detectors

Application

SuperDuct detectors are ideally suited to duct smoke detection applications where early indication of combustion is required within the confined space of ventilation ductwork. Its primary purpose is to provide early warning of an impending fire and to prevent smoke from circulating throughout the building. It is typically used to detect smoke in the supply side of the HVAC system but can provide supervision of the return side as well.

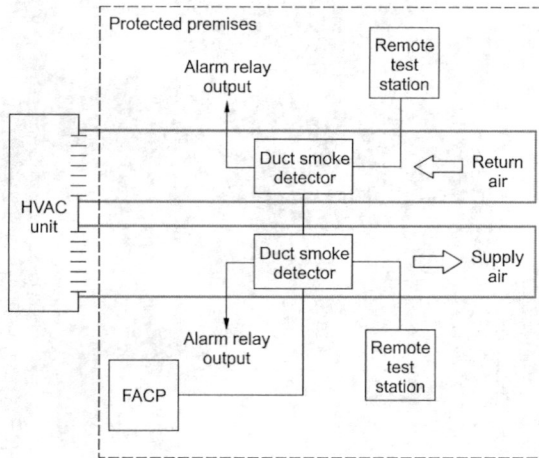

SuperDuct detectors continually sample air flow in the HVAC duct and initiate an alarm condition whenever smoke is detected. An alarm is activated when the quantity (percent obscuration) of combustion products in that air sample exceeds the detector's sensitivity setting.

Signature Series Intelligence

Like all Signature detectors, the SIGA-SD features electronic addressing and issues a dirty sensor warning when it reaches its preset limit. The dirty sensor warning indicates the sensor is operating within its specified limits but is in need of servicing. When the detector's ability to compensate for environmental changes has reached its limit, the duct smoke detector signals a trouble condition.

The SIGA-SD also uses differential sensing to prevent gradual environmental changes from triggering unwanted alarms. A rapid change in environmental conditions, such as smoke from a fire, causes the detector to signal an alarm state, but dust and debris accumulated over time does not change alarm sensitivity.

Each Signature Series *SuperDuct* detector contains a microprocessor that performs comprehensive self-diagnostics and stores the results in nonvolatile memory. Stored results include details such as hours of operation, last maintenance date, and number of alarms and troubles. This information can be retrieved and reviewed when desired.

Detector Configuration

The detector assembly cover provides easy access to the smoke sensor, its wiring connections, sample and exhaust tubes, and the smoke chamber itself.

Air enters the detector's sensing chamber through a sampling tube (ordered separately) that extends into the duct and is directed back into the ventilation system through an exhaust tube (included). The difference in air pressure between the two tubes pulls the sampled air through the sensing chamber. When a sufficient amount of smoke is detected in the sensing chamber, the detector initiates an alarm.

The sampling tube may be installed from either the duct side of the assembly or from inside the sensor compartment, as preferred by the installer. (The exhaust tube must be installed from the duct side.) Sampling tubes may be rotated in 45-degree increments so that air-holes can be aligned to allow the unit to be mounted at virtually any angle relative to the air flow.

In installations where the duct smoke detector's controls and indicators are hidden from view, a remote test station or an LED indicator can be connected to the detector to provide these functions.

Remote Test Stations

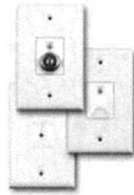

Labor-saving Remote Test/Reset stations provide alarm testing from the convenience of a remote location. Tests can be performed quickly and safely – without having to climb to the roof. Magnetically-operated and key-operated one-gang models are available. Signature *SuperDuct* detectors are also compatible with SIGA-LED remote alarm LED.

Air velocity in the duct as low as 100 ft/min. maintains adequate air flow into the sensor smoke chamber through air holes in the air sampling tube and discharges through the exhaust tube. *SuperDuct* air sampling tubes must be installed with the inlet holes facing the airstream. Sampling tubes may be rotated in 45-degree increments so that air-holes can be aligned to allow the unit to be mounted in virtually any angle relative to the airflow.

SuperDuct sensors are engineered to operate optimally under the harsh environmental conditions frequently found in HVAC ductwork. Nonetheless, before installing the detector, test the duct air velocity, temperature, and humidity to verify that it is within the operating range of the *SuperDuct* detector. Consult the *SuperDuct* installation sheet for details.

Dimensions

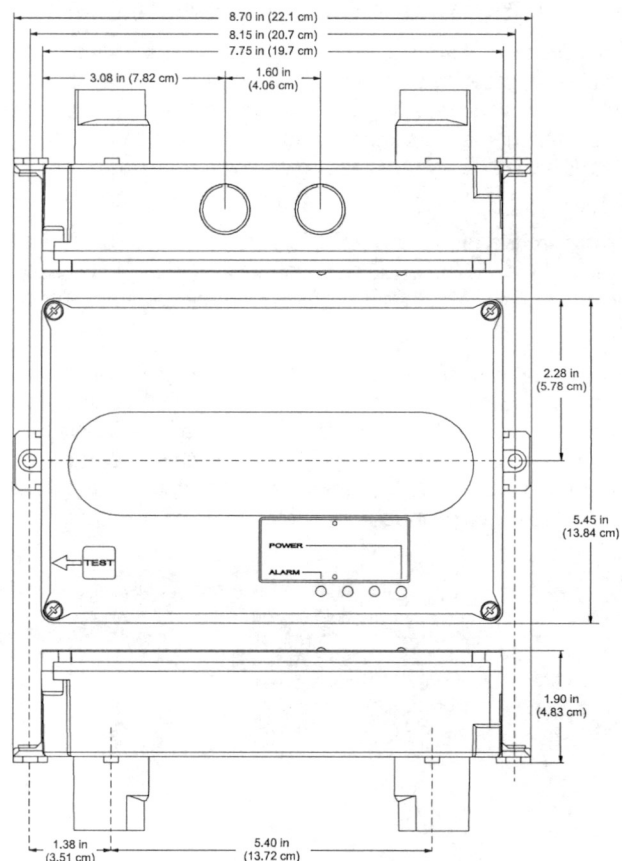

Assembly

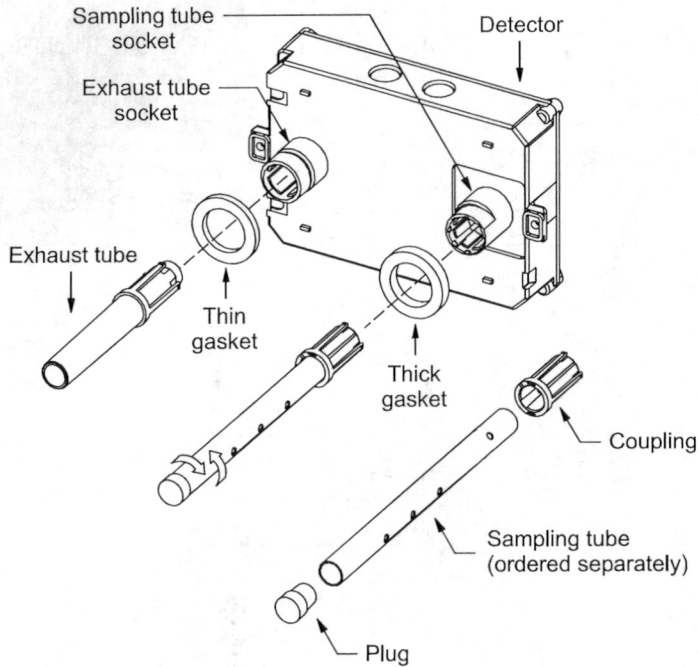

Mounting

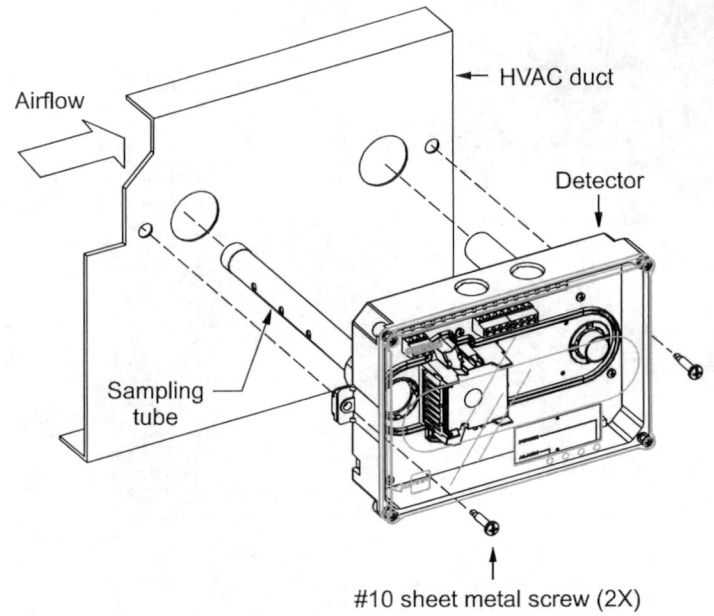

Wiring

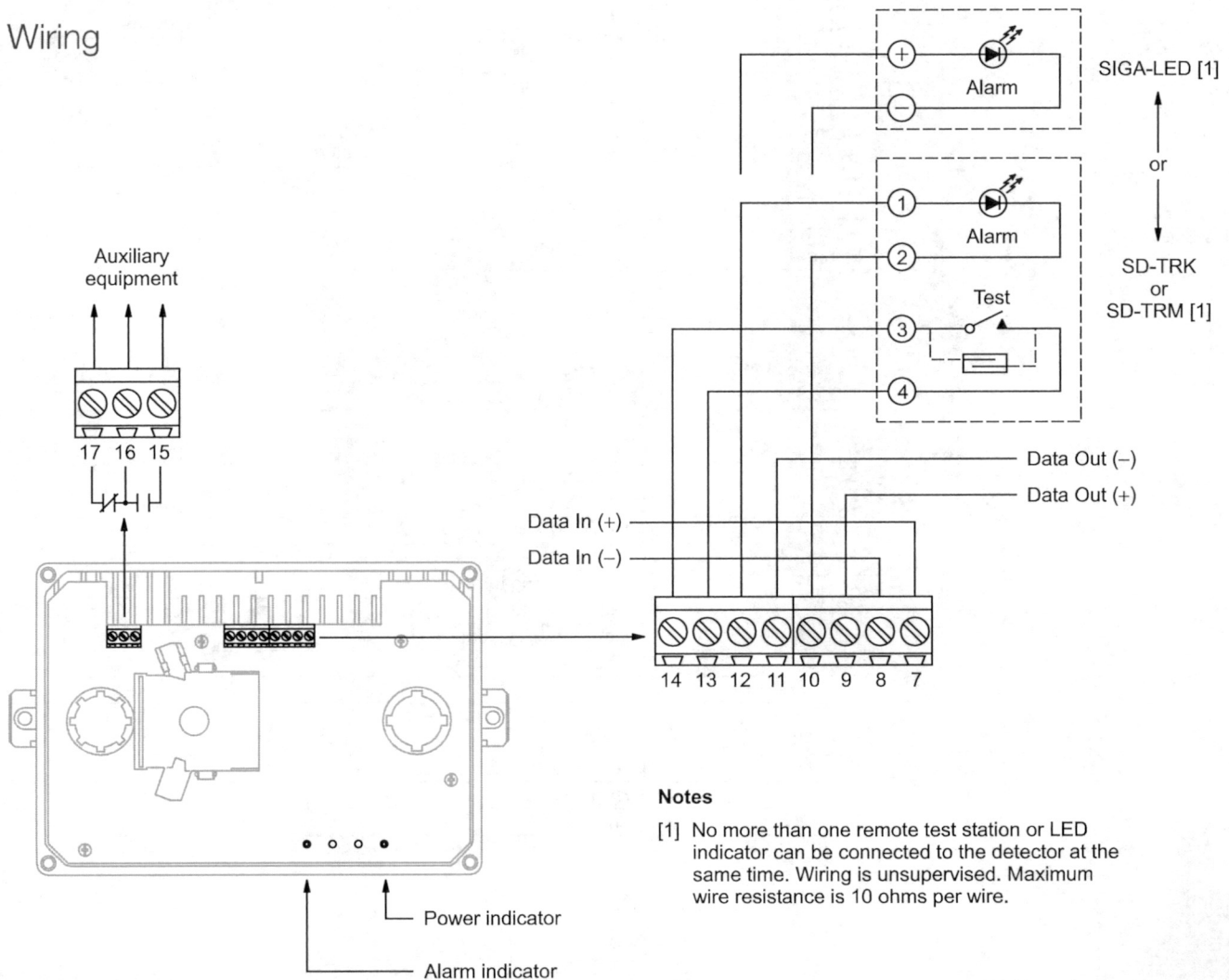

Notes

- [1] No more than one remote test station or LED indicator can be connected to the detector at the same time. Wiring is unsupervised. Maximum wire resistance is 10 ohms per wire.



Detection & alarm since 1872

U.S.
T 888-378-2329
F 866-503-3996

Canada
Chubb-Edwards
T 519 376 2430
F 519 376 7258

Southeast Asia
T : +65 6391 9300
F : +65 6391 9306

India
T : +91 80 4344 2000
F : +91 80 4344 2050

Australia
T +61 3 9239 1200
F +61 3 9239 1299

Europe
T +32 2 725 11 20
F +32 2 721 86 13

Latin America
T 305 593 4301
F 305 593 4300

utcfireandsecurity.com

© 2010 UTC Fire & Security.
All rights reserved.

Specifications, detector

Dimensions	8.70 x 5.45 x 1.90 inches (221 x 138 x 48 mm)
Wire size	14 to 22 AWG
Detection method	Photoelectric (light scattering principle)
Air velocity rating	100 to 4,000 ft/min and meets the required minimum air pressure differential
Air pressure differential	0.005 to 1.00 inches of water
Sensitivity	0.79 to 2.46 %/ft obscuration
Alarm test response time	5 seconds
LED indicators	Alarm (red), Power (green)
Common alarm relay	Unsupervised and power- limited Quantity: 1 Type: Form C Ratings: 2.0 A at 30 Vdc (resistive)
Operating voltage	15.2 to 19.95 Vdc
Operating current	Standby: 45 µA Alarm: 45 µA Inrush: 1 mA Standalone alarm: 18 mA
Operating environment	Temperature (UL): -4 to 158 °F (-29 to 70 °C). Temperature (ULC): -4 to 120 °F (-29 to 49 °C) Relative humidity: 10 to 93%, noncondensing
Agency listings	UL, ULC, CSFM, FM, MEA

Specifications, test stations

Remote Test/Reset Stations provide alarm test, trouble indication, and reset capability from a remote location. They include a one-gang plate, momentary SPST switch, red alarm LED, and terminal block. Magnetically-operated models (TRM) or key-operated models (TRK) are available.

Compatible electrical boxes	North American 1-gang box Standard 4-in square box, 1-1/2 inches deep, with 1-gang cover
LED indicators	Alarm (red)
LED type	Clear lens
Wire size	14 to 22 AWG
Resistance per wire	10 Ohms, max.
Current requirements	See controller specifications
LED circuit ratings	Voltage: 3 Vdc, max. Current: 30 mA, max.
Switch ratings (SD-TRK)	Voltage: 125 Vdc, max. Current: 4 A, max.
Switch ratings (SD-TRM)	Voltage: 200 Vdc, max. Current: 0.5 A, max.
Compatible detectors	SuperDuct conventional two-wire and Signature duct smoke detectors
Operating environment	-4°F to 158°F (-20°C to 70°C) Humidity: 93% RH, noncondensing
Storage temperature	-4 to 140 °F (-20 to 60 °C)
Agency listings	UL, ULC, CSFM

Ordering Information

Catalog Number	Description	Ship Wt., lb. (kg)
SIGA-SD	Intelligent SuperDuct Detector	2.4 (1.1)
Accessories		
SD-T8	8-inch sampling tube	0.5 (0.2)
SD-T18	18-inch sampling tube	1.5 (0.7)
SD-T24	24-inch sampling tube	2.7 (1.2)
SD-T36	36-inch sampling tube	3.0 (1.4)
SD-T42	42-inch sampling tube	3.5 (1.6)
SD-T60	60-inch sampling tube	5.8 (2.6)
SD-T78	78-inch sampling tube	7.5 (3.4)
SD-T120	120-inch sampling tube	11.5 (5.2)
SIGA-LED	Remote alarm LED	1.0 (0.5)
SD-TRM	Remote test station, magnetic	1.0 (0.5)
SD-TRK	Remote test station, keyed	1.0 (0.5)
SD-VTK	Air velocity test kit (stoppers only, etc)	1.0 (0.5)
SD-GSK	Cover gasket kit	0.5 (0.2)
SD-MAG	Test magnet kit	0.5 (0.2)
SIGA-SDPCB	Replacement PCB/Signature sensor kit	1.0 (0.5)



Manual Pull Stations

SIGA-270, SIGA-270P,
SIGA-278



Overview

The SIGA-270 and SIGA-278 series Manual Pull Stations are part of EST's Signature Series system. The SIGA-270 Fire Alarm Manual Pull Stations feature our very familiar teardrop shape. They are made from die-cast zinc and finished with red epoxy powder-coat paint complemented by aluminum colored stripes and markings. With positive pull-lever operation, one pull on the station handle breaks the glass rod and turns in a positive alarm, ensuring protection plus fool-proof operation. Presignal models (SIGA-270P) are equipped with a general alarm (GA) keyswitch for applications where two stage operation is required. The up-front highly visible glass rod discourages tampering, but is not required for proper operation.

EST's double action single stage SIGA-278 station is a contemporary style manual station made from durable red colored lexan. To initiate an alarm, first lift the upper door marked "LIFT THEN PULL HANDLE", then pull the alarm handle.

Standard Features

Note: Some features described here may not be supported by all control systems. Check your control panel's Installation and Operation Guide for details.

- **Traditional familiar appearance**
SIGA-270 models feature our familiar teardrop design with simple positive pull action and sturdy die-cast metal body.
- **One stage (GA), two stage (pre-signal), and double action models**
SIGA-270 models are available for one or two stage alarm systems. The single stage double action SIGA-278 features a rugged Lexan housing with keyed reset mechanism.

- **Break glass operation**
An up-front visible glass rod on the SIGA-270 discourages tampering.
- **Intelligent device with integral microprocessor**
All decisions are made at the station allowing lower communication speed while substantially improving control panel response time. Less sensitive to line noise and loop wiring properties; twisted or shielded wire is not required.
- **ADA Compliant**
Meets ADA requirements for manual pull stations.
- **Electronic Addressing with Non-volatile memory**
Permanently stores programmable address, serial number, type of device, and job number. Automatically updates historic information including hours of operation, last maintenance date, number of alarms and troubles, and time and date of last alarm.
- **Automatic device mapping**
Each station transmits wiring information to the loop controller regarding its location with respect to other devices on the circuit.
- **Stand-alone operation**
The station inputs an alarm even if the loop controller's polling interrogation stops.
- **Diagnostic LEDs**
Status LEDs; flashing GREEN shows normal polling; flashing RED shows alarm state.
- **Designed for high ambient temperature operation**
Install in ambient temperatures up to 120 °F (49 °C).

Application

The operating characteristics of the fire alarm stations are determined by their sub-type code or "Personality Code". NORMALLY-OPEN ALARM - LATCHING (Personality Code 1) is assigned by the factory; no user configuration is required. The device is configured for Class B IDC operation. An ALARM signal is sent to the loop controller when the station's pull lever is operated. The alarm condition is latched at the station.

Compatibility

Signature Series manual stations are compatible only with EST's Signature Loop Controller.

Warnings & Cautions

This device will not operate without electrical power. As fires frequently cause power interruption, we suggest you discuss further safeguards with your local fire protection specialist.

Testing & Maintenance

To test (or reset) the station simply open the station and operate the exposed switch. The SIGA-270 series are opened with a tool; the SIGA-278 requires the key which is supplied with that station.

The station's automatic self-diagnosis identifies when it is defective and causes a trouble message. The user-friendly maintenance program shows the current state of each Signature series device and other pertinent messages. Single devices may be deactivated temporarily, from the control panel. Availability of maintenance features is dependent on the fire alarm system used.

Scheduled maintenance (Regular or Selected) for proper system operation should be planned to meet the requirements of the Authority Having Jurisdiction (AHJ). Refer to current NFPA 72 and ULC CAN/ULC 536 standards.

Typical Wiring

The fire alarm station's terminal block accepts #18 AWG (0.75mm²) to #12 AWG (2.5mm²) wire sizes. See Signature Loop Controller catalog sheet for detailed wiring requirement specifications.

Wiring Notes

1. Refer to Signature Loop Controller manual for maximum wire distance.
2. All wiring is power limited and supervised.

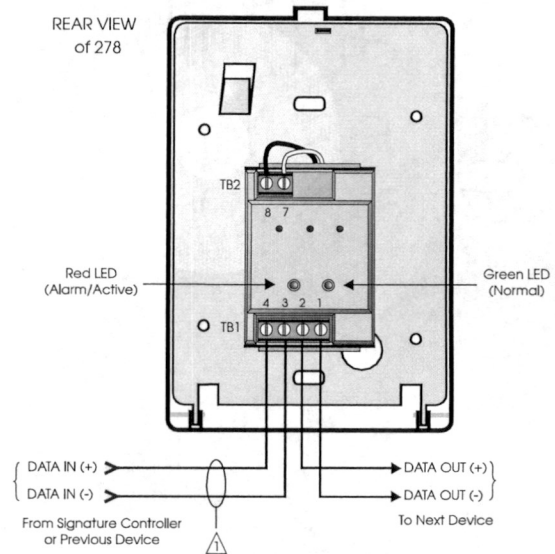

Figure 4. Single Stage Systems

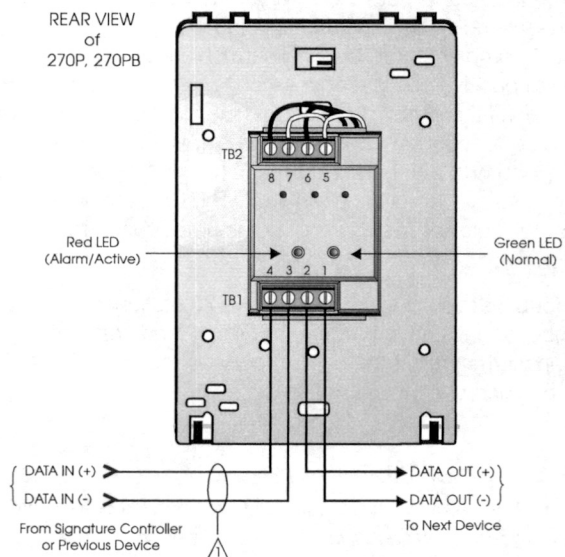

Figure 5. Two Stage Systems

Installation

Single-stage Signature Series fire alarm manual pull stations mount to North American 2½ inch (64 mm) deep 1-gang boxes.

Two stage presignal (270P) models require 1½ inch (38 mm) deep 4-inch square boxes with 1-gang, ½-inch raised covers. Openings must be angular. *Rounded openings are not acceptable.* Recommended box: Steel City Model 52-C-13; in Canada, use Iberville Model CI-52-C-49-1/2.

All models include terminals are suited for #12 to #18 AWG (2.5 mm² to 0.75 mm²) wire size. Edwards recommends that these fire alarm stations be installed according to latest recognized edition of national and local fire alarm codes.

Electronic Addressing: The loop controller electronically addresses each manual station, saving valuable time during system commissioning. Setting complicated switches or dials is not required. Each station has its own unique serial number stored in its on-board memory. The loop controller identifies each device on the loop and assigns a "soft" address to each serial number. If desired, the stations can be addressed using the SIGA-PRO Signature Program/Service Tool.

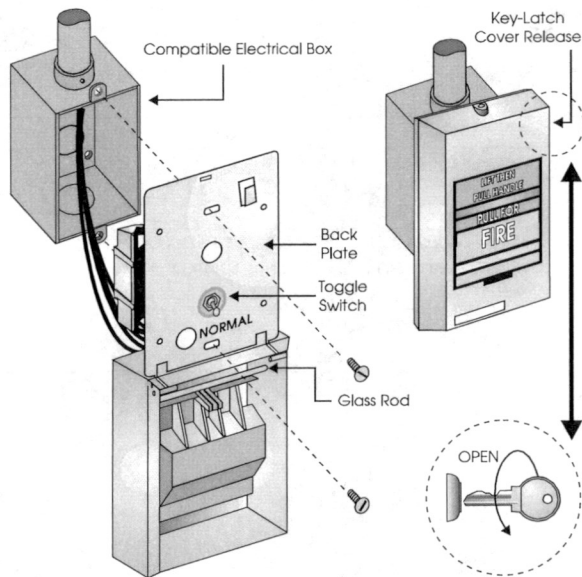

Figure 1. SIGA-278 installation

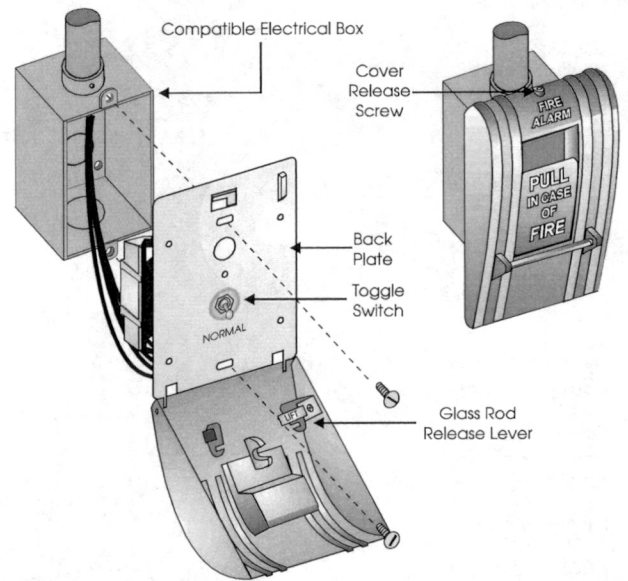

Figure 2. SIGA-270, SIGC-270F, SIGC-270B installation

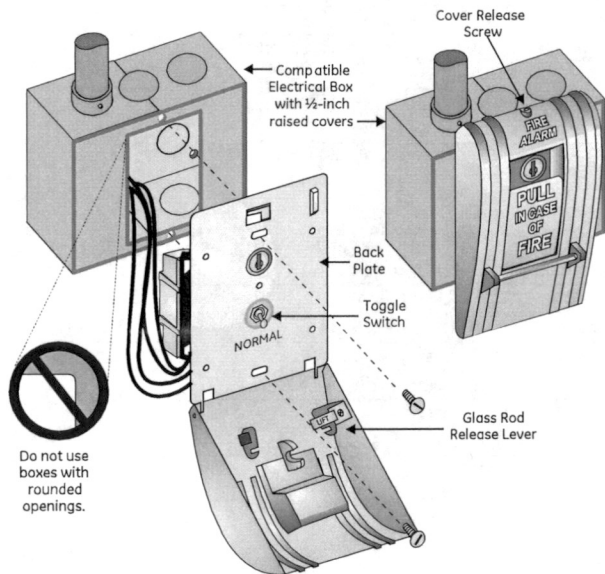

Figure 3. SIGA-270P, SIGC-270PB installation



Detection & alarm since 1872

U.S.
T 888-378-2329
F 866-503-3996

Canada
Chubb-Edwards
T 519 376 2430
F 519 376 7258

Southeast Asia
T : +65 6391 9300
F : +65 6391 9306

India
T : +91 80 4344 2000
F : +91 80 4344 2050

Australia
T +61 3 9239 1200
F +61 3 9239 1299

Europe
T +32 2 725 11 20
F +32 2 721 86 13

Latin America
T 305 593 4301
F 305 593 4300

utcfireandsecurity.com

© 2010 UTC Fire & Security.
All rights reserved.

Specifications

Catalog Number	SIGA-270, SIGC-270F, SIGC-270B	SIGA-270P, SIGC-270PB	SIGA-278
Description	Single Action - One Stage	Single Action - Two Stage (Presignal)	Double Action - One Stage
Addressing Requirements	Uses 1 Module Address	Uses 2 Module Addresses	Uses 1 Module Address
Operating Current	Standby = 250µA Activated = 400µA	Standby = 396µA Activated = 680µA	Standby = 250µA Activated = 400µA
Construction & Finish	Diecast Zinc - Red Epoxy with aluminum markings		Lexan - Red with white markings
Type Code	Factory Set		
Operating Voltage	15.2 to 19.95 Vdc (19 Vdc nominal)		
Storage and Operating Environment	Operating Temperature: 32°F to 120°F (0°C to 49°C) Storage Temperature: -4°F to 140°F (-20°C to 60°C) Humidity: 0 to 93% RH		
LED Operation	On-board Green LED - Flashes when polled On-board Red LED - Flashes when in alarm Both LEDs - Glow steady when in alarm (stand-alone)		
Compatibility	Use With: Signature Loop Controller		
Agency Listings	UL, ULC (note 1), MEA, CSFM		

Note: SIGC-270F, SIGC-270B and SIGC-270PB are ULC listed only. Suffix "F" indicates French markings. Suffix "B" indicates English/French bilingual markings.

Ordering Information

Catalog Number	Description	Ship Wt. lbs (kg)
SIGA-270	One Stage Fire Alarm Station, English Markings - UL/ULC Listed	
SIGC-270F	One Stage Fire Alarm Station, French Markings - ULC Listed	
SIGC-270B	One Stage Fire Alarm Station, French/English Markings - ULC Listed	
SIGA-270P	Two Stage (Presignal) Fire Alarm Station, English Markings - UL/ULC Listed	1 (0.5)
SIGC-270PB	Two Stage (Presignal) Fire Alarm Station, French/English Markings - ULC Listed	
SIGA-278	Double Action (One Stage) Fire Alarm Station, English Markings - UL/ULC Listed	

Accessories

32997	GA Key w/Tag - for pre-signal station (CANADA ONLY)	
276-K2	GA Key - for pre-signal station (USA ONLY)	
276-K1	Station Reset Key, Supplied with all Key Reset Stations	
27165	12 Glass Rods - for SIGA-270 series (CANADA ONLY)	0.1 (.05)
270-GLR	20 Glass Rods - for SIGA-270 series (USA ONLY)	
276-GLR	20 Glass Rods - for SIGA-278 series	
276B-RSB	Surface Mount Box, Red - for SIGA pull stations	1 (0.6)



LIFE SAFETY & INCIDENT MANAGEMENT

Field Configurable Horns and Strobes

Genesis Series



ECS/MNS appliances available
with clear or amber lenses.

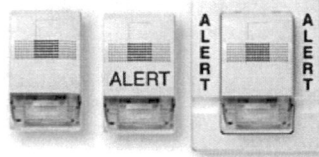

Overview

The Genesis line of fire alarm and mass notification/emergency communications (ECS/MNS) signals are among the smallest, most compact audible-visible life safety signaling devices in the world. About the size of a deck of playing cards, these devices are designed to blend with any decor.

Thanks to patented breakthrough technology, EDWARDS Genesis strobes do not require bulky specular reflectors and lenses. Instead, an exclusive cavity design conditions light to produce a highly controlled distribution pattern. Significant development efforts employing this new technology have given rise to a new benchmark in strobe performance – FullLight technology.

FullLight strobe technology produces a smooth light distribution pattern without the spikes and voids characteristic of specular reflectors. This ensures the entire coverage area receives consistent illumination from the strobe flash. As a result, Genesis strobes with FullLight technology go well beyond the UL-1971 and ULC-S526 light distribution requirements.

Genesis strobes and horn-strobes offer selectable candela output by means of a conveniently-located switch on the side of the device. Models are also available that offer fixed 15/75 cd output. The candela output setting remains clearly visible even after final installation, yet it stays locked in place to prevent unauthorized tampering.

Genesis ECS/MNS appliances offer emergency signaling with clear or amber lenses and with optional ALERT housing labels. They are ideal for applications that require differentiation between fire alarm and mass notification alerts.

Standard Features

- **Unique low-profile design**
 - The most compact UL-1971/ULC-S526 listed strobe available
 - Ultra-slim – protrudes less than one inch
 - Attractive appearance
 - No visible mounting screws
- **Four field-configurable options in one device**
 - Select 15, 30, 75, or 110 cd strobe output
 - Select high (default) or low dB horn output
 - Select temporal (default) or steady horn output
 - Select public mode flash rate (default) or private mode temporal flash
- **Fixed 15/75 cd model available**
- **ECS/MNS models available**
- **Easy to install**
 - Fits standard 1-gang electrical boxes – no trim plate needed
 - Optional trim plate accommodates oversized openings
 - Pre-assembled with captive hardware
 - #12 AWG terminals – ideal for long runs or existing wiring
- **Unparalleled performance**
 - Industry's most even light distribution
 - Meets tough synchronizing standards for strobes
 - Single microprocessor controls both horn and strobe
 - Independent horn control over a single pair of wires
 - Highly regulated in-rush current
 - Multiple frequency tone improves sound penetration
 - Field-programmable temporal strobe output option

Application

Genesis strobes are UL 1971-listed for use indoors as wall-mounted public-mode notification appliances for the hearing impaired. Prevailing codes require strobes to be used where ambient noise conditions exceed 105 dBA (87dBA in Canada), where occupants use hearing protection, and in areas of public accommodation as defined in the *Americans with Disabilities Act* (see application notes – USA).

Combination horn-strobe signals must be installed in accordance with guidelines established for strobe devices. Consult with your Authority Having Jurisdiction for details.

All Genesis strobes exceed UL synchronization requirements (within 10 milliseconds over a two-hour period) when used with a synchronization source. Synchronization is important in order to avoid epileptic sensitivity.

WARNING: These devices will not operate without electrical power. As fires frequently cause power interruptions, further safeguards such as backup power supplies may be required.

Horns

Genesis horn output reaches as high as 99 dB and features a unique multiple frequency tone that results in excellent sound penetration and an unmistakable warning of danger. Horns may be configured for either coded or non-coded signal circuits. They can also be set for low dB output with a jumper cut that reduces horn output by about 5 dB. Horn-only models may be ceiling-mounted or wall-mounted.

The suggested sound pressure level for each signaling zone used with alarm signals is at least 15 dB above the average ambient sound level, or 5 dB above the maximum sound level having a duration of at least 60 seconds, whichever is greater, measured 5 feet (1.5 m) above the floor. The average ambient sound level is, A-weighted sound pressure measured over a 24-hour period.

Doubling the distance from the signal to the ear will theoretically result in a 6 dB reduction of the received sound pressure level. The actual effect depends on the acoustic properties of materials in the space. A 3 dBA difference represents a barely noticeable change in volume.

ECS/MNS Applications

Genesis ECS/MNS strobe appliances bring the same high-performance fire alarm features and unobtrusive design to mass notification applications. Available with amber lenses and optional ALERT housing labels, they are ideal for applications that require differentiation between fire alarm and mass notification alerts.

Installation

Genesis horns and strobes mount to any standard one-gang surface or flush electrical box. Matching optional trim plates are used to cover oversized openings and can accommodate one-gang, two-gang, four-inch square, or octagonal boxes, and European 100 mm square.



Genesis Horn/Strobe with optional trim plate

All Genesis signals come pre-assembled with captive mounting screws for easy installation. Two tabs at the top of the signal unlock the cover to reveal the mounting hardware. The shallow depth of Genesis devices leaves ample room behind the signal for extra wiring. Once installed with the cover in place, no mounting screws are visible.

Field Configuration

Temporal horn and horn-strobe models are factory set to sound in a **three-pulse temporal pattern**. Units may be configured for use with coded systems by cutting a jumper on the circuit board. This results in a **steady output** that can be turned on and off (coded) as the system applies and removes power to the signal circuit. A Genesis Signal Master is required when horn-strobe models are configured for coded systems. Non-temporal, horn-only models sound a steady tone.

Genesis clear strobes and horn-strobes are shipped from the factory ready for use as **UL 1971 compliant** signals for public mode operation. These signals may be configured for **temporal flash** by cutting a jumper on the circuit board. This battery-saving feature is intended for private mode signaling only.

Genesis clear strobes and horn-strobes may be set for **15, 30, 75, or 110 candela output**. The output setting is changed by simply opening the device and sliding the switch to the desired setting. The device does not have to be removed to change the output setting. The setting remains visible through a small window on the side of the device after the cover is closed.

Horns and horn-strobes are factory set for **high dB output**. **Low dB output** may be selected by cutting a jumper on the circuit board. This reduces the output by about 5 dB.

Wiring

Field wiring terminals accommodate #18 to #12 AWG (0.75 mm² to 2.5 mm²) wiring. Horns, strobes, and combination horn-strobes are interconnected with a single pair of wires as shown below.

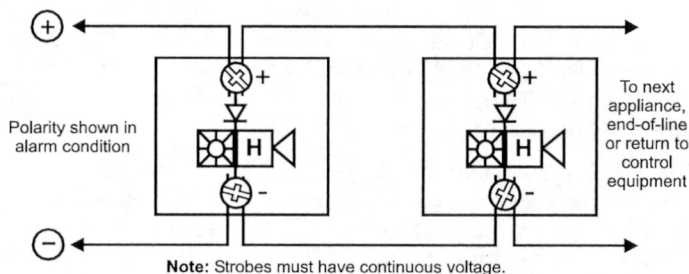

Current Draw

Strobes, Horn-Strobes

Multi-cd Wall Strobes (G1-VM)

UL Rating	15 cd*	30 cd*	15/75 cd**	75 cd*	110 cd*
	RMS	RMS	RMS	RMS	RMS
16 Vdc	103	141	152	255	311
16 Vfwr	125	179	224	346	392

*G1-VM multi-cd; **G1F-V1575 fixed 15/75 cd

Typical Current	15 cd	30 cd	15/75	75 cd	110 cd
	RMS	RMS	RMS	RMS	RMS
16 Vdc	85	127	150	245	285
20 Vdc	71	98	123	188	240
24 Vdc	59	82	104	152	191
33 Vdc	46	64	84	112	137
16 Vfwr	119	169	223	332	376
20 Vfwr	103	143	189	253	331
24 Vfwr	94	129	169	218	262
33 Vfwr	87	112	148	179	205

Wall Temporal Horn-strobes – High dB Setting

UL Rating	15 cd*	30 cd*	15/75 cd**	75 cd*	110 cd*
	RMS	RMS	RMS	RMS	RMS
16 Vdc	129	167	172	281	337
16 Vfwr	176	230	269	397	443

*G1-HDVM multi-cd
**G1F-HDV1575 fixed 15/75 cd

Typical Current	15 cd	30 cd	15/75	75 cd	110 cd
	RMS	RMS	RMS	RMS	RMS
16 Vdc	102	135	160	246	309
20 Vdc	88	109	137	193	248
24 Vdc	81	94	122	161	203
33 Vdc	74	72	106	124	154
16 Vfwr	144	182	247	352	393
20 Vfwr	141	162	220	274	362
24 Vfwr	136	152	203	235	282
33 Vfwr	125	144	196	201	232

Wall Temporal Horn-strobes – Low dB Setting

UL Rating	15 cd*	30 cd*	15/75 cd**	75 cd*	110 cd*
	RMS	RMS	RMS	RMS	RMS
16 Vdc	122	160	146	274	330
16 Vfwr	162	216	231	383	429

*G1-HDVM multi-cd
**G1F-HDV1575 fixed 15/75 cd

Typical Current	15 cd	30 cd	15/75	75 cd	110 cd
	RMS	RMS	RMS	RMS	RMS
16 Vdc	96	130	158	243	302
20 Vdc	79	104	133	189	241
24 Vdc	68	88	119	156	197
33 Vdc	56	71	100	118	146
16 Vfwr	128	180	241	344	389
20 Vfwr	118	157	213	266	343
24 Vfwr	113	144	195	230	279
33 Vfwr	112	137	182	197	226

Horns

Wall or Ceiling Mounted Temporal Horns (G1-HD)

UL Rating	High dB (RMS)	Low dB (RMS)
16 Vdc	26	19
24 Vdc	36	27
33 Vdc	41	33
16 Vfwr	51	37
24 Vfwr	69	52
33 Vfwr	76	70

Typical Current	High dB (RMS)	Low dB (RMS)
	16 Vdc	22
20 Vdc	24	19
24 Vdc	27	22
33 Vdc	32	26
16 Vfwr	34	30
20 Vfwr	40	34
24 Vfwr	45	38
33 Vfwr	52	47

Wall or Ceiling Mounted Horns (G1-P)

UL Designation	Voltage Range	Max. Current, RMS
Regulated 24 Vdc	16 - 33 Vdc	13 mA
24 fwr	16 - 33 Vfwr	11 mA

Typical Current	RMS
24 Vdc	10
24 Vdc	11
31 Vdc	12
20 Vfwr	9
24 Vfwr	10

Current values are shown in mA.

dBA output

Temporal Horns, Horn-strobes (G1-HD, G1-HDVM series)

High dB Setting	UL464		Average	Peak
	Temporal	Steady	Temporal/ Steady	Temporal/ Steady
16 Vdc	81.4	85.5	91.4	94.2
24 Vdc	84.4	88.6	94.5	97.6
33 Vdc	86.3	90.4	96.9	99.5

Low dB Setting	UL464		Average	Peak
	Temporal	Steady	Temporal/ Steady	Temporal/ Steady
16 Vdc	76.0	80.1	86.3	89.2
24 Vdc	79.4	83.5	89.8	92.5
33 Vdc	82.1	86.5	92.5	95.3

Steady Tone Horns (G1-P series)

	UL464	Average	Peak
16 Vdc	77 dBA, min	85 dBA	91 dBA
16 Vfwr	77 dBA, min	85 dBA	91 dBA

Notes

1. All values shown are dBA measured at 10 feet (3.01m).
2. UL464 values measured in reverberant room.
3. Average and Peak values are measured in anechoic chamber.

Average Sound Output (dBA)

(High dB setting, anechoic, 24V, measured at 10ft)

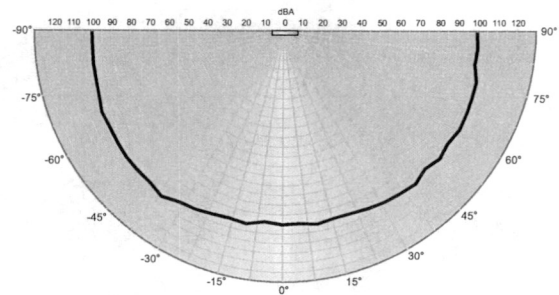

Light output - (effective cd)

Percent of UL rating versus angle

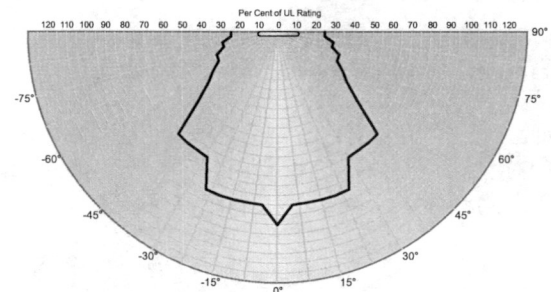

Specifications

Housing	Red or white textured UV stabilized, color impregnated engineered plastic. Exceeds 94V-0 UL flammability rating.
Lens	Optical grade polycarbonate (clear)
Mounting (indoor only)	Strobes and horn-strobes are for wall-mount installation only. Horn-only models may be ceiling- or wall-mounted. Flush mount: 2½ inch (64 mm) deep one-gang box Surface mount: Model 27193 surface mount box, wiremold box, or equivalent surface-mount box With optional trim plate: One-gang, two-gang, four-inch square, octagonal, or European single-gang box
Wire connections	Screw terminals: single input for both horn and strobe. #18 to #12 AWG (0.75 mm ² to 2.5 mm ²) wire size
Operating environment	Indoor only: 32-120°F (0-49°C) ambient temperature. 93% relative humidity
Agency listings/approvals	UL 1971 (S218), UL 1638 (S218), UL 464 (S218), ULC S525, ULC S526, CSFM, CE, FCC, MEA. (All models comply with ADA Code of Federal Regulation Chapter 28 Part 36 Final Rule.)
Dimensions (HxWxD)	Signal: 4-1/2" x 2-3/4" x 13/16" (113 mm x 68 mm x 21 mm) Trimplate: 5" (127 mm); Height - 5-7/8" (149 mm); Depth - ½" (13 mm)
Operating voltage	G1-HD series temporal-tone horns: non-coded, filtered 16-33 Vdc or unfiltered 16-33 Vdc FWR (or coded when horn set to steady tone) G1-HDVM series temporal-tone horn-strobes: non-coded, filtered 16-33 Vdc or unfiltered 16-33 Vdc FWR (or coded (audible NAC only) when used with optional G1M Genesis Signal Master) G1-VM series strobes: non-coded, filtered 16 - 33 Vdc or unfiltered 16-33 Vdc FWR G1-P series steady-tone horns: coded or non-coded, filtered 20-31 Vdc or unfiltered 20-27 Vfwr
Strobe output rating	UL 1971, UL 1638, ULC S526: selectable 15 cd, 30 cd, 75 cd, or 110 cd output UL 1971: 15 cd (fixed 15/75 cd models) UL 1638, ULCS526: 75 cd (fixed 15/75 cd models)
Strobe flash rate	G1-VM strobes and G1-HDVM series temporal-tone horn-strobes: one flash per second synchronized with optional G1M Genesis Signal Master indefinitely within 10 milliseconds. Temporal setting (private mode only): synchronized to temporal output of horns on same circuit
Synchronization Sources	SIGA-CC1S, SIGA-MCC1S, SIGA-CC2A, SIGA-MCC2A, G1M-RM BPS6A, BPS10A, APS6A, APS10A, iO64, iO500, Fireshield Plus 3, 5 and 10 zone. Add G1M for G1-CVM & G1-HDVM devices only.
Horn pulse rate	G1-HD temporal-tone horns and G1-HDVM series temporal-tone horn-strobes: temporal rate synchronized with optional G1M Genesis Signal Master indefinitely within 10 milliseconds. G1-P steady-tone horns: continuous, steady tone only
Temporal audible pattern	½ sec ON, ½ sec OFF, ½ sec ON, ½ sec OFF, ½ sec ON, 1½ sec OFF, then repeat cycle

Candela Output

Lens Color	Rating	Switch Position A	Switch Position B	Switch Position C	Switch Position D
Amber	UL 1638	110 cd	75 cd	30 cd	15 cd
Amber	UL 1971*	88 cd	60 cd	24 cd	12 cd
Clear	UL 1971	110 cd	75 cd	30 cd	15 cd

* Equivalent Rating

Fire appliances available with white or red housings.

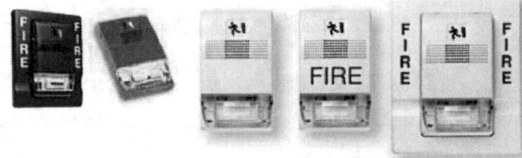

ECS/MNS appliances available with clear or amber lenses.



Ordering Information

Model	Housing	Marking	Lens	Strobe	Horn	Ship Wt. lbs (kg)
-------	---------	---------	------	--------	------	-------------------

Fire Alarm Appliances (c/w running man icon screen printed on housing)

G1-VM	White	None	Clear	Selectable 15, 30, 75, or 110 cd	Strobe only	0.25 (0.11)
G1F-HD	White	FIRE	Clear	Horn only	Selectable high/low dB	0.25 (0.11)
G1F-HDV1575	White	FIRE	Clear	15/75 cd ¹	Temporal hi/lo dB-24V	0.25 (0.11)
G1F-HDVM	White	FIRE	Clear	Selectable 15, 30, 75, or 110 cd	Selectable high/low dB	0.25 (0.11)
G1F-P	White	FIRE	Clear	Steady Horn (not compatible with Genesis Signal Master)		0.25 (0.11)
G1F-V1575	White	FIRE	Clear	15/75 cd ¹	Strobe only	0.25 (0.11)
G1F-VM	White	FIRE	Clear	Selectable 15, 30, 75, or 110 cd	Strobe only	0.25 (0.11)
G1-HD	White	None	Clear	Horn only	Selectable high/low dB	0.25 (0.11)
G1-HDVM	White	None	Clear	Selectable 15, 30, 75, or 110 cd	Selectable high/low dB	0.25 (0.11)
G1-P	White	None	Clear	Steady Horn (not compatible with Genesis Signal Master)		0.25 (0.11)
G1RF-HD	Red	FIRE	Clear	Horn only	Selectable high/low dB	0.25 (0.11)
G1RF-HDV1575	Red	FIRE	Clear	15/75 cd ¹	Temporal hi/lo dB-24V	0.25 (0.11)
G1RF-HDVM	Red	FIRE	Clear	Selectable 15, 30, 75, or 110 cd	Selectable high/low dB	0.25 (0.11)
G1RF-P	Red	FIRE	Clear	Steady Horn (not compatible with Genesis Signal Master)		0.25 (0.11)
G1RF-V1575	Red	FIRE	Clear	15/75 cd ¹	Strobe only	0.25 (0.11)
G1RF-VM	Red	FIRE	Clear	Selectable 15, 30, 75, or 110 cd	Strobe only	0.25 (0.11)
G1R-HD	Red	None	Clear	Horn only	Selectable high/low dB	0.25 (0.11)
G1R-HDVM	Red	None	Clear	Selectable 15, 30, 75, or 110 cd	Selectable high/low dB	0.25 (0.11)
G1R-P	Red	None	Clear	Steady Horn (not compatible with Genesis Signal Master)		0.25 (0.11)
G1R-VM	Red	None	Clear	Selectable 15, 30, 75, or 110 cd	Strobe only	0.25 (0.11)

ECS/MNS Appliances (no running man icon on housing)

G1WA-VMA	White	ALERT	Amber	Selectable A, B, C or D	Strobe only	0.25 (0.11)
G1WA-VMC	White	ALERT	Clear	Selectable 15, 30, 75, or 110 cd	Strobe only	0.25 (0.11)
G1WN-VMA	White	None	Amber	Selectable A, B, C or D	Strobe only	0.25 (0.11)
G1WN-VMC	White	None	Clear	Selectable 15, 30, 75, or 110 cd	Strobe only	0.25 (0.11)

Trim Plates

G1T	White	None	Genesis Trim Plate (for two-gang or 4" square boxes)			0.15 (0.7)
G1RT	Red	None	Genesis Trim Plate (for two-gang or 4" square boxes)			0.15 (0.7)
G1T-FIRE	White	FIRE	Genesis Trim Plate (for two-gang or 4" square boxes)			0.15 (0.7)
G1RT-FIRE	Red	FIRE	Genesis Trim Plate (for two-gang or 4" square boxes)			0.15 (0.7)
G1WT-ALERT	White	ALERT	Genesis Trim Plate (for two-gang or 4" square boxes)			0.15 (0.7)

Surface Boxes

27193-16	White	N/A	One-gang surface mount box			1 (0.4)
27193-11	Red	N/A	One-gang surface mount box			1 (0.4)

¹ These 15/75 cd models provide fixed output and are not multi-candela devices. The 15 cd output component complies with UL1971, while the 75 cd output component complies with UL 1638.

Outdoor Rated Horns and Horn-Strobes

Genesis WG4 Series



Overview

Genesis WG4 Series horns and horn-strobe appliances are among the most versatile emergency appliances of their kind. Rated for indoor or outdoor use, they are suitable for a wide range of wet and harsh environments with a listed operating temperature range of as low as -40 °F to as high as 151 °F (-40 °C to 66 °C).

Field-configurable light and sound output settings add to their on-site flexibility, while optional FIRE markings make them ideal for fire alarm applications.

These appliances are suitable for indoor and outdoor applications, and are ideal for challenging conditions such as parking garages and process areas. They are available for mounting on the ceiling or the wall, and thanks to an ingenious optional full backplane sealing gasket, can be installed to recessed (in-the-pour/block) electrical boxes. WG4 notification appliances also mount to suitable surface boxes. Optional color-matched trim skirts provide a clean, finished appearance. All appliance wiring is accomplished room-side for easy installation.

WG4 Series appliances feature an efficient and powerful piezo sounder. The multi-candela strobes are available with clear lenses in two output categories – standard and high-output. They are precision-timed to meet UL 1971 synchronization standards, and field-configurable for one of four candela intensities. Candela settings are viewable even after installation through an innovative sealed viewport display.

Standard Features

- Outdoor and indoor rated
- Low-profile design
- Wall or ceiling mount
- Room-side wiring accepts 18 to 12 AWG (0.75 to 2.5 mm²)
- Wide operating temperature range
- Field-selectable settings
- Fully-compatible with Genesis synchronization protocols
- Standard and high-output strobe intensities
- Horn only and horn-strobe options

Application

Horns

Genesis horn output reaches as high as 97 dBA in accordance with UL 464 (104 dBA in accordance with ULC-S525) and features a unique frequency tone that results in excellent sound penetration and an unmistakable warning of danger. Horns may be configured for either coded or non-coded notification circuits. They can also be set for low dB output with a jumper cut that reduces horn output by about 5 dB.

The suggested sound pressure level for each notification zone used with alarm notification appliances is at least 15 dB above the average ambient sound level, or 5 dB above the maximum sound level having a duration of at least 60 seconds, whichever is greater, measured 5 feet (1.5 m) above the floor. The average ambient sound level is A-weighted (fast response) sound pressure measured over a 24-hour period.

Doubling the distance from the notification appliance to the ear will theoretically result in a 6 dB reduction of the received sound pressure level. The actual effect depends on the acoustic properties of materials in the space. A 3 dBA difference represents a barely noticeable change in volume.

Strobe Application

Genesis clear-lensed strobes are UL 1971-listed for use indoors as wall- or ceiling-mounted public-mode notification appliances for the hearing impaired, and UL 1638-listed for outdoor applications. Prevailing codes require strobes to be used where ambient noise conditions exceed specified levels, where occupants use hearing protection, and in areas of public accommodation.

Visible appliance synchronization is required to avoid causing issues with people who have Photosensitive Epilepsy (PSE). Notification appliance synchronization is also generally required when more than two strobe appliances are in the same field of view from any one location. All Genesis strobes meet UL synchronization requirements (within 10 milliseconds over a two-hour period) when used with a synchronization source.

WARNING: These devices will not operate without electrical power. As fires frequently cause power interruptions, we suggest you discuss further safeguards with your local fire protection specialist.

Edwards recommends that these devices always be installed in accordance with the latest recognized edition of national and local codes. Refer to the appropriate codes and standards for mounting height information.

Installation and Mounting

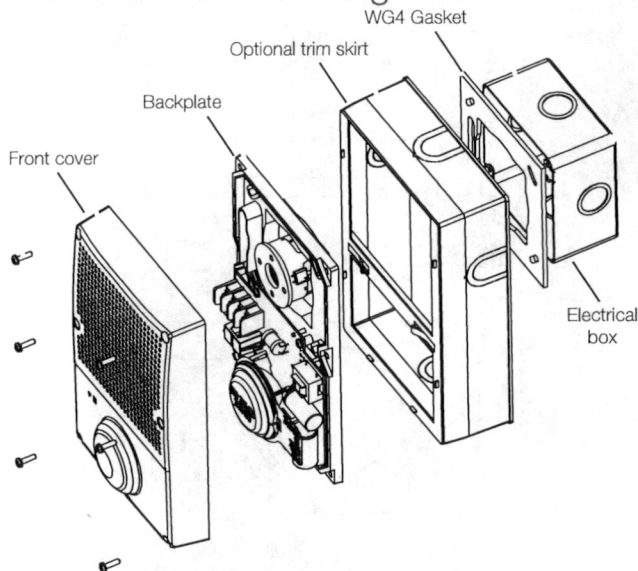

WG4 notification appliances are rated for outdoor use and are suitable for indoor or outdoor applications on walls or ceilings. For surface-mounting in outdoor or wet applications, appliances must be mounted to a 449 or 74347U electrical box. In dry conditions, they are compatible with standard 4-inch square by 1½-inch deep electrical boxes. When using the optional WG4WTS or WG4RTS trim skirt, a 449 or 4-inch square by 2-1/8" deep box must be used.

The Genesis WG4 horn and horn-strobe may be wall- or ceiling-mounted, and may be placed in one of four positions: strobe above, strobe below, and strobe to either side. The shallow depth of Genesis devices leaves room behind the appliance for extra wiring.

Field Configuration

Horn pattern: Audible output for WG4 horns and horn-strobes is factory set to sound in a three-pulse temporal pattern. Units may be configured for use with coded systems by cutting a JP1 on the circuit board. This results in a steady output that can be turned on and off (coded) as the system applies and removes power to the notification circuit. A Genesis Signal Master is required when horn-strobe models are configured for coded systems.

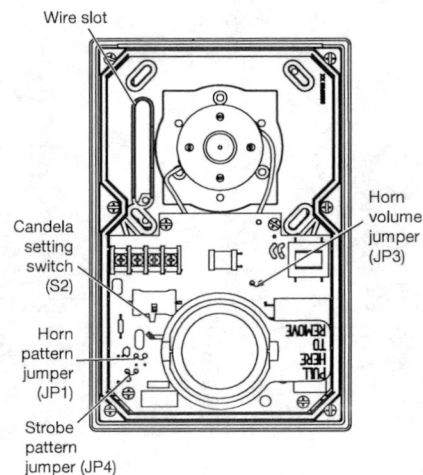

Horn output: Horns and horn-strobes are factory set for high dB output. Low dB output may be selected by cutting a jumper on the circuit board. This reduces the output by about 5 dB.

Strobe pattern: Genesis WG4 horn-strobes are factory set for use as UL 1971 compliant notification appliances for public mode operation. These notification appliances may be configured for temporal flash by cutting JP4 on the circuit board. This battery-saving feature is intended for private mode signaling only.

Strobe output: Genesis WG4 horn-strobes may be set for one of four output intensities. The output setting is changed by simply opening the device and sliding the switch to the desired setting. The device does not have to be removed to change the output setting. The setting remains visible after the cover is closed through a small window on the front of the device.

Wiring

Field wiring is connected to WG4 notification appliances with terminals that accommodate #18 to #12 AWG (0.75 mm² to 2.5 mm²) wiring.

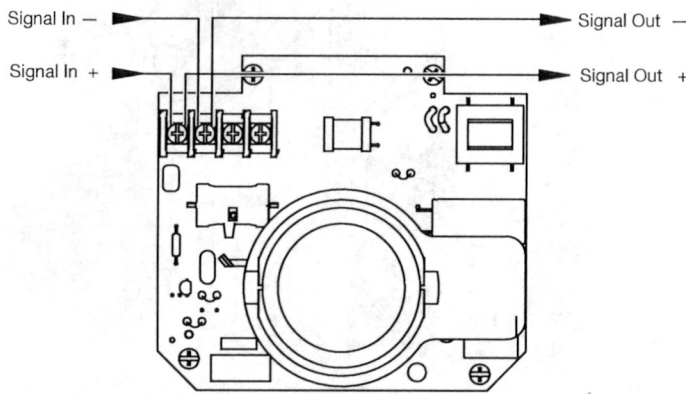

-/+ designations indicate the signal polarity required to activate the device.

Specifications

Horns and Horn-strobes

Operating voltage	24 VDC, 24 VFWR nominal
Dimensions (W x H x D)	5.6 x 8.5 x 1.4 in. (142 x 216 x 36 mm)
Horn tone	3.2 kHz
Wire size	12 to 18 AWG (0.75 to 2.50 mm ²)
Compatible electrical box	
Outdoor	Model 449 or 74347U
Indoor	4 in. square by 1.5 in. deep box
Operating environment	
Temperature	-40 to 151°F (-40 to 66°C)
Relative humidity	0 to 95% noncondensing

Compatible Synchronization Sources

Horn-strobes

Auto-sync Output Modules	SIGA-CC1S, SIGA-CC2A, SIGA-MCC1S, SIGA-MCC2A
Genesis Signal Master	G1M-RM
Booster & Auxiliary Power Supplies	APS6A, APS10A, BPS6A, BPS10A
Control Panels with Genesis Synchronization built-in	FireShield Plus, iO Series, EST3X

Sound Output

Horns and Horn-strobes (dBA)

Volume Setting	16V		24V		33V	
	UL 464	ULC-S525	UL 464	ULC-S525	UL 464	ULC-S525
Continuous High	89.7	94.0	94.7	99.6	97.4	102.9
Continuous Low	85.4	92.8	89.5	97.2	92.5	98.6
Temporal High	84.2	96.5	90.5	100.5	93.5	104.2
Temporal Low	81.7	90.3	85.4	94.2	88.1	97.0

dBA = Decibels, A-weighted.

UL 464: Sound level output measured in a reverberant room at 10 ft. (3.05m).

CAN/ULC-S525: Sound level output measured in an anechoic room at 10ft (3.05m).

Light Output

Horizontal Plot

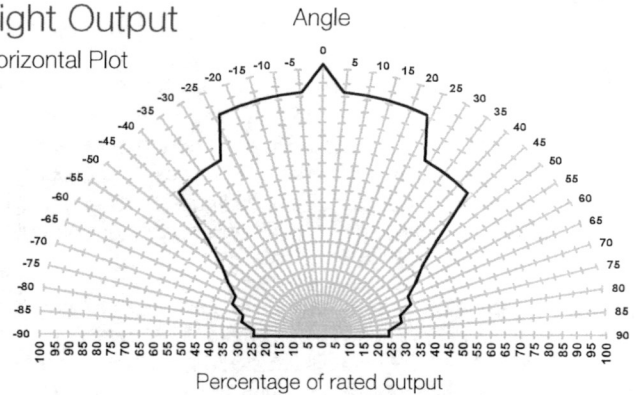

Standard Candela Horn-strobes

Standard/rating		Strobe Switch Position			
		D	C	B	A
UL 1971	Indoor	15 cd	29 cd	70 cd	87 cd
UL 1638	Outdoor @ -35°C	6 cd	12 cd	28 cd	35 cd
CAN/ULC-S525	Outdoor @ -40°C	1 cd	3 cd	8 cd	10 cd

High Candela Horn-strobes

Standard/rating		Strobe Switch Position			
		D	C	B	A
UL 1971	Indoor	102cd	123cd	147cd	161cd
UL 1638	Outdoor @ -35°C	41cd	50 cd	60 cd	65 cd
CAN/ULC-S525	Outdoor @ -40°C	11 cd	14 cd	17 cd	18 cd

Operating Current

(UL specifies current ratings at 16 volts)

Standard Candela Horn-strobes in RMS (mA), continuous

Input Voltage	Strobe Switch Position			
	D	C	B	A
16 VDC	127	168	297	351
16 VFWR	218	239	393	422
24 VDC	107	130	210	238
24 VFWR	190	222	325	356

High Candela Horn-strobes in RMS (mA), continuous

Input Voltage	Strobe Switch Position			
	D	C	B	A
16 VDC	342	408	517	526
16 VFWR	447	502	614	679
24 VDC	240	271	327	365
24 VFWR	390	400	486	540

Horn only models (mA)

Setting	16V RMS, continuous		24V, typical	
	High dB	Low dB	High dB	Low dB
VDC	69.1	41.2	49.0	32.3
VFWR	135	91.3	99.1	67.1



Detection & alarm since 1872

U.S.
T 888 378 2329
F 866 503 3996

Canada
Chubb Edwards
T 519 376 2430
F 519 376 7258

Southeast Asia
T : +65 6391 9300
F : +65 6391 9306

India
T : +91 80 4344 2000
F : +91 80 4344 2050

Australia
T +61 3 9239 1200
F +61 3 9239 1299

Europe
T +32 2 725 11 20
F +32 2 721 86 13

Latin America
T 305 593 4301
F 305 593 4300

utcfireandsecurity.com

© 2012 UTC Fire & Security.
All rights reserved.

Ordering Information

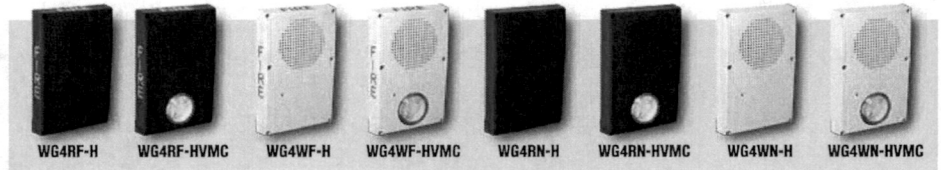

Model	Housing	Marking	Strobe Output	Ship Wt.
WG4RF-HVMC	Red	FIRE	Selectable standard candela output	1.5 lbs. (0.68 kg)
WG4WF-HVMC	White			
WG4RN-HVMC	Red	None	Selectable high candela output	
WG4WN-HVMC	White			
WG4RF-HVMHC	Red	FIRE	Selectable high candela output	
WG4WF-HVMHC	White			
WG4RN-HVMHC	Red	None	Horn Only	
WG4WN-HVMHC	White			
WG4RF-H	Red	FIRE	Horn Only	
WG4WF-H	White			
WG4RN-H	Red	None	Horn Only	
WG4WN-H	White			

Accessories

WG4WTS	Surface Skirt for Genesis WG4 appliance family, white.
WG4RTS	Surface Skirt for Genesis WG4 appliance family, red.
WG4GSKT	Full Body Mounting Gasket for smooth surfaces, WG4 appliance family
74347U	Surface mount box, outdoor rated, red
449	Surface mount box, outdoor rated, gray