



1120 sqft
350 sqft
1070 sqft Total Approx.

Finish open Storage

Verify headroom

Finish up stairs
+ Bonus room

RECREATION ROOM PLAN
SCALE 1/4" = 1'-0"

Total
350 sqft
Approx.

LEGEND
4" FINISH WALL
CONCRETE WALL
CONCRETE SLAB
CONCRETE FLOOR
CONCRETE CEILING
CONCRETE TYPICAL
CONCRETE TYPICAL
CONCRETE TYPICAL

NOTE:
FRAMES AND WALLS UNLESS
OTHERWISE NOTED
UNLESS OTHERWISE SPECIFIED.

FLOOR PLAN
SCALE 1/4" = 1'-0"
REVISIONS:
NO. DATE DESCRIPTION
1 06-11-18 REVISIONS TO PERMITS
2 06-11-18 REVISIONS TO PERMITS

PROVIDE ALL ELECTRICAL, GAS, LIGHT, PHONE, TV, CABLE, AND SATELLITE SERVICE TO ALL ROOMS. PROVIDE ALL NECESSARY ELECTRICAL, GAS AND PHONE SERVICE TO ALL ROOMS. PROVIDE ALL NECESSARY ELECTRICAL, GAS AND PHONE SERVICE TO ALL ROOMS.

NOTE:
TO AVOID CLASH TO HARD PARTS
REVISIONS TO PERMITS
REVISIONS TO PERMITS
REVISIONS TO PERMITS

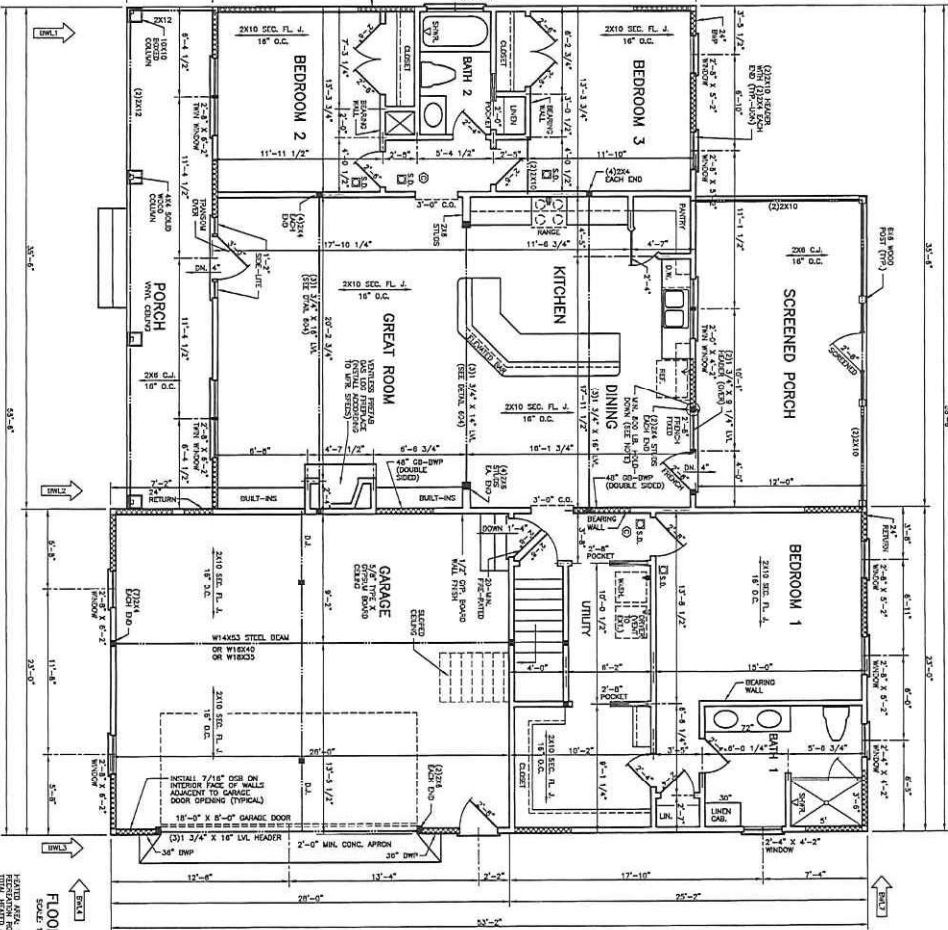

Standard Homes Plan Service, Inc.
7200 SUNSET LAKE ROAD FLOYD-WALKER, IN 47128
(810)502-6877

DESIGNED BY	DATE	SCALE	SHEET
KIRSTEN	2	SID.	3 OF 6

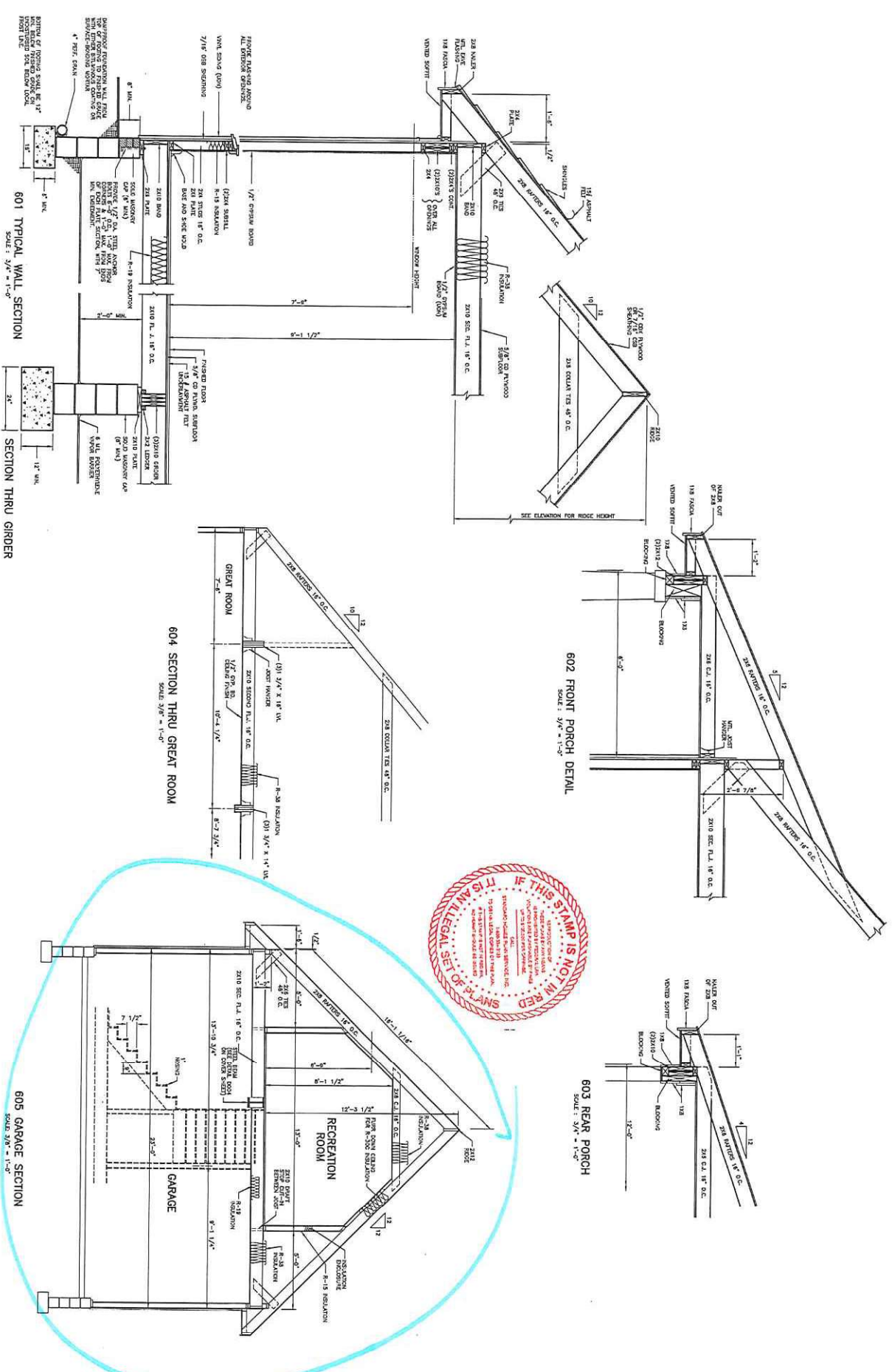

601 TYPICAL WALL SECTION
SCALE: 3/8" = 1'-0"

SECTION THRU GIRDER

602 FRONT PORCH DETAIL
SCALE: 3/8" = 1'-0"

603 REAR PORCH
SCALE: 3/8" = 1'-0"

604 SECTION THRU GREAT ROOM
SCALE: 3/8" = 1'-0"

605 GARAGE SECTION
SCALE: 3/8" = 1'-0"



Standard Homes Plan Service, Inc.
7100 SHERET LAKE ROAD FLORENCE-VISITA, NC 27538
(919)522-9977

DESIGNED FOR	PLAN	NO.	SHEET
ENGR. AND ARCHT. SEALS	KIRSTEN	2	6 OF 6
INTD. 06-11-14		S.D.	

2495 Sheriff Johnson Rd

Project Cost \$ 90,000

Unfinished Attic + Rec. Room will be done
at the same time. Under same permit

Scope of Work:

- Recreation Room is already framed with Knee Wall
we will fur down the rafters to receive R-38 insulation.
- Unfinished Attic Area build 2x4 Knee walls + fur
down rafters with 2x4 to receive R-38 Insulation
- Insulation to code, Baffles, R-15 walls, R-38 Ceiling, caulk
- Electrical to code
- Install HVAC unit to code

CONTINUOUS ROOF LINE (TYPICAL)

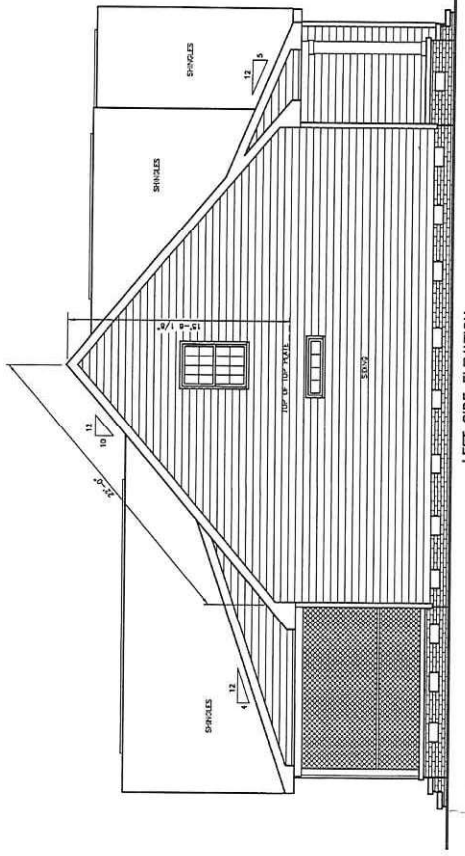

LEFT SIDE ELEVATION
SCALE: 1/4" = 1'-0"

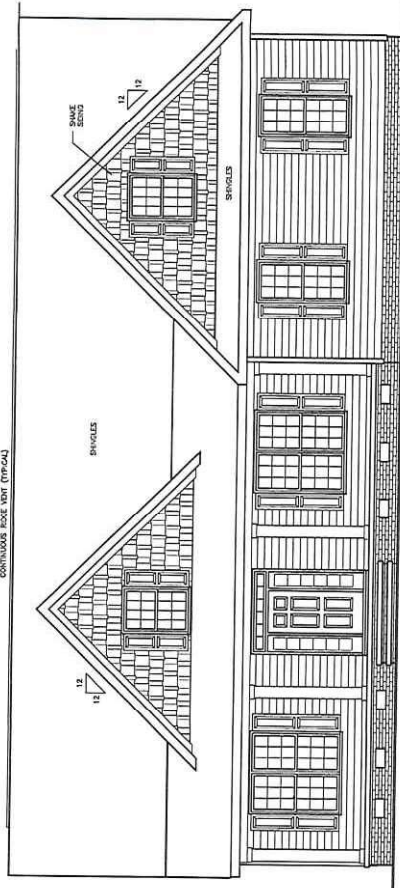

FRONT ELEVATION
SCALE: 1/4" = 1'-0"

PLEASE REFER TO SPECIFICATIONS AND DETAILS
ACCORDING TO LOCAL CODE AND BUILDING CONVENTIONS.
ALL DIMENSIONS SHALL GROSS UNLESS NOTED OTHERWISE.
FROM FINISH.

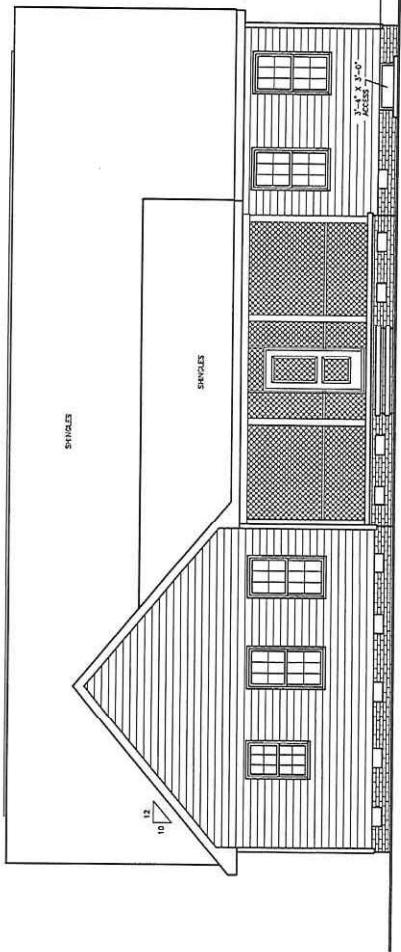

REAR ELEVATION
SCALE: 1/4" = 1'-0"

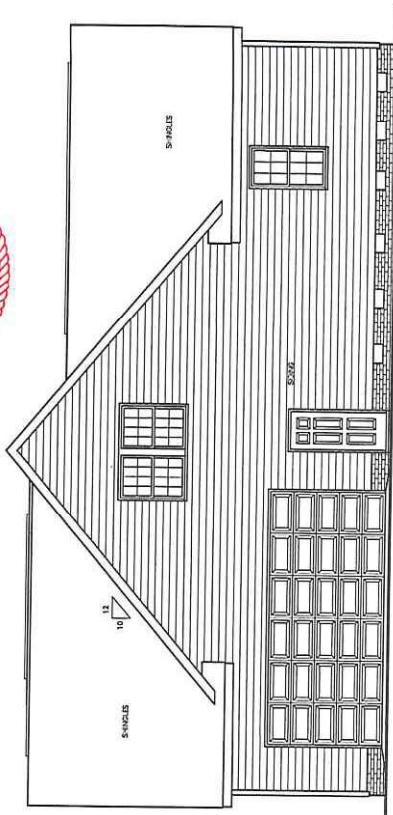

RIGHT SIDE ELEVATION
SCALE: 1/4" = 1'-0"



Standard Homes Plan Service, Inc.
7200 BIRCH LAKE BLVD. SUITE 100, WILSON, NC 27604
(919) 532-3677



DESIGNED FOR
FRANK AND TAYLOR WEAVERS

PLAN
KIRSTEN

NO.
2

SHEET
5 OF 6

REVISED 09-15-18

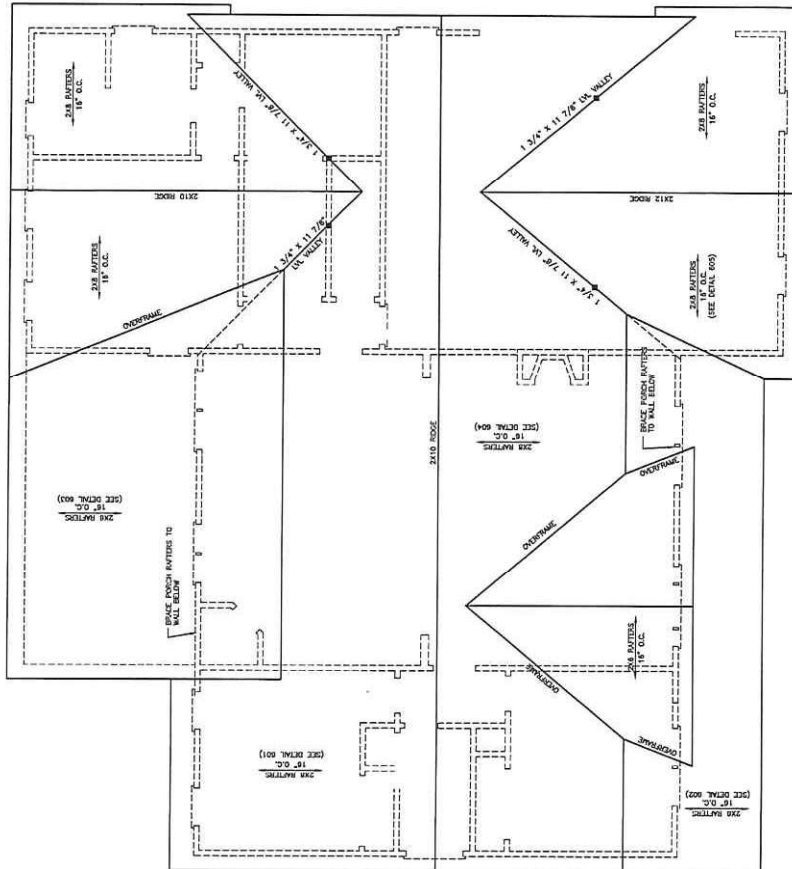

WITH VENTILATION REQUIREMENTS 1
 2007 SEC. 17-15B - 15.4 FEET MAX. REQUIRED

ROOF PLAN
 SCALE: 1/4" = 1'-0"



Standard Homes Plan Service, Inc.

7200 SUNSET LAKE ROAD - FAULKNER-WASSILA, NC 27526
 (919)552-5877
BEFORE CONSTRUCTION CHECK LOCAL REGULATIONS



DESIGNED FOR
 FRANK AND TAYLOR PLUSIS

PLAN
 KIRSTEN

NO. 2

PROJECT NO.	18-15-118
DATE	12/18/18
SHEET	4 OF 6
MPL.	SID.
NO.	2

CONNECTION OF MULTIPLE PLY BEAMS

(INSTALLATION & CONNECTION OF BEAMS SHALL BE ACCORDING TO MANUFACTURERS SPECIFICATIONS)

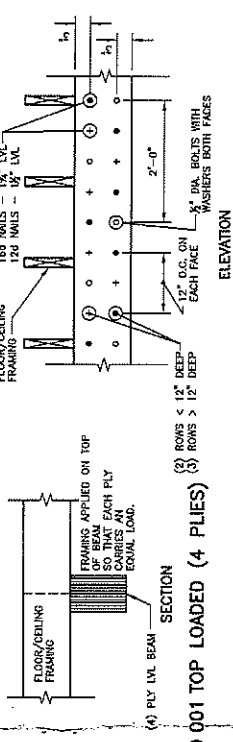

D 001 TOP LOADED (4 PLYS)

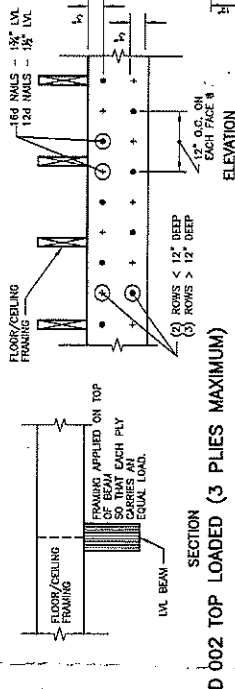

D 002 TOP LOADED (3 PLYS MAXIMUM)

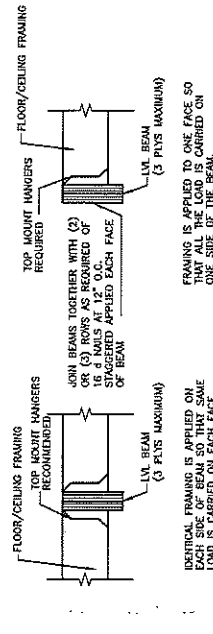

D 003 SIDE LOADED

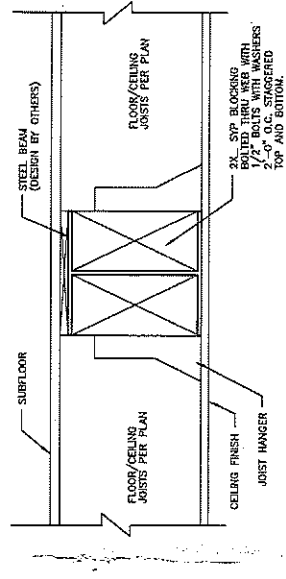

D 004 SECTION THRU STEEL BEAM

DESIGN CRITERIA:
 ALL DESIGN LOAD ASSUMPTIONS FOR ROOF, CEILING, AND FLOOR HAVE BEEN USED IN THE PREPARATION OF THIS PLAN UNLESS OTHERWISE NOTED.

	LIVE LOAD	DEAD LOAD	TOTAL LOAD	DEFLECTION (Δ)
ROOF (REDUCTION OR HIGH SLOPE)	20 P.S.F.	10 P.S.F.	30 P.S.F.	L / 180
CEILING (1/2\"/>				

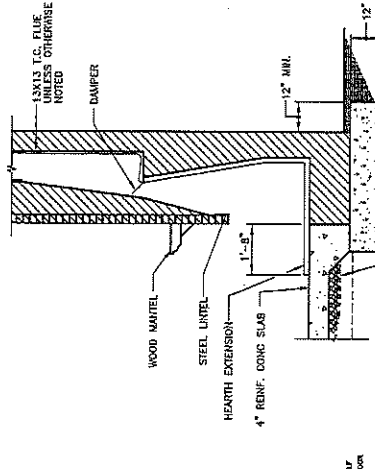
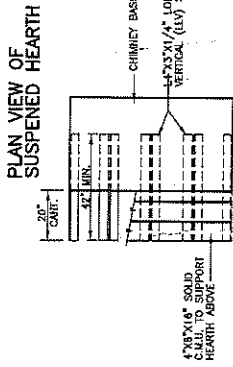

D 005 SECTION THRU FIREPLACE ON CONCRETE SLAB

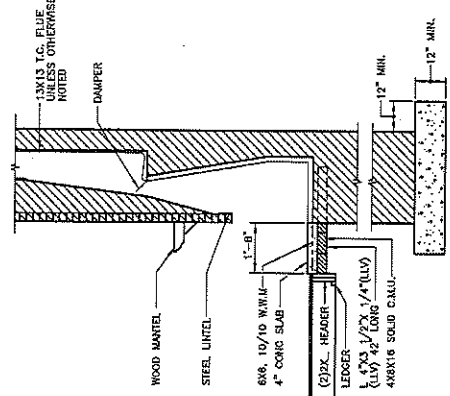

D 006 SECTION THRU FIREPLACE ON WOOD FLOOR

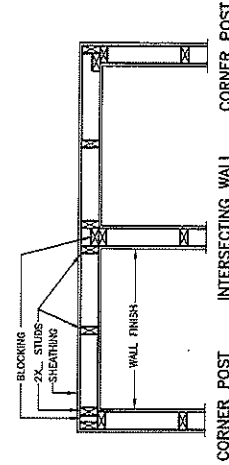

D 007 DETAIL BASIC WALL FRAMING

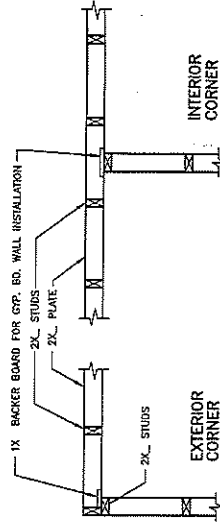

D 008 DETAIL ADVANCED WALL FRAMING



Standard Homes Plan Service, Inc.
 7200 SUNSET LAKE ROAD FUQUAY-VARINA, NC 27506
 (919) 552-5677



STANDARD CONSTRUCTION DETAILS

D

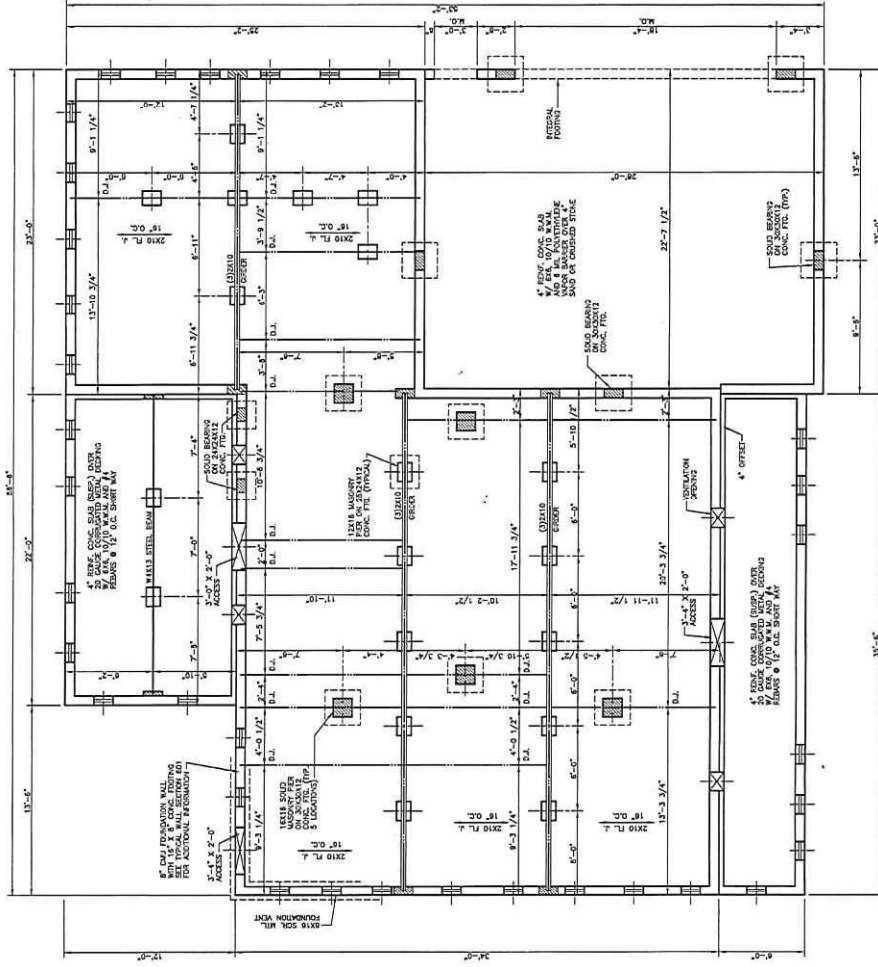

FOUNDATION PLAN
SCALE 1/4" = 1'-0"

FOUNDATION VIBRATION REQUIREMENTS:
2370 SO. FL. - 150 - 151 SO. FL. INT
FREE ROOM REED.
FRAME 54 LVLTS. PER. 100% VIB. RED.
CONCRETE FLOORING 100% VIB. RED.
CONCRETE FLOORING 100% VIB. RED.



Standard Homes Plan Service, Inc.
7200 SUNSET LAKE ROAD FARMYVILLE, NC 27826 (919)552-5877
SEE OUR WEBSITE AT WWW.STANDARDHOMES.COM



DESIGNED FOR
RANDY AND TAMERA WELLS

PLAN
KIRSTEN

NO. 2

SID. 2

DATED 05-16-11
SHEET 2 OF 6

