

I HAVE RESEARCHED THIS CHAPTER AND THE LOUISIANA STATE UNIFORM CONSTRUCTION CODE AND TO THE BEST OF MY KNOWLEDGE AND BELIEF, THESE DRAWINGS ARE IN COMPLIANCE THEREWITH. I TAKE FULL RESPONSIBILITY FOR THE CONTENTS OF THESE PLANS.

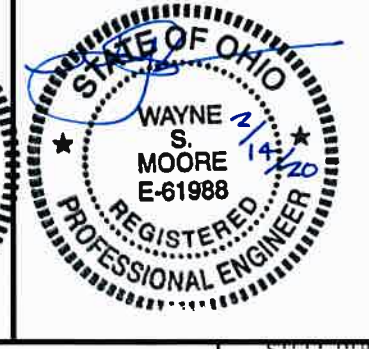

MOORE AND ASSOCIATES ENGINEERING AND CONSULTING, INC.

DRAWN BY: LT
CHECKED BY: PDH

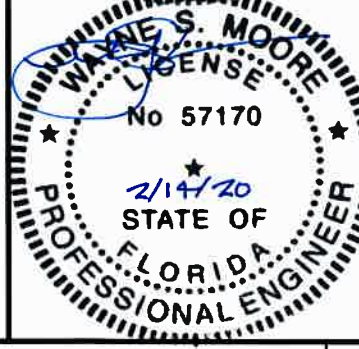
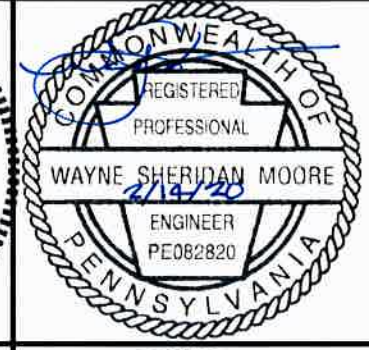
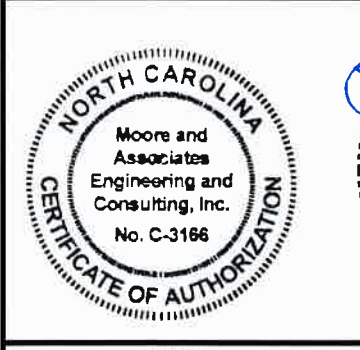
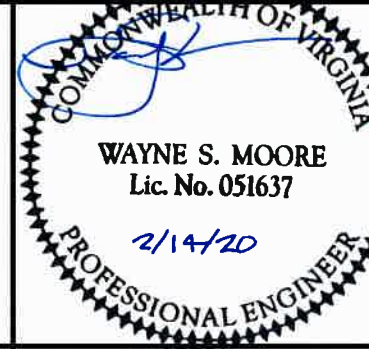
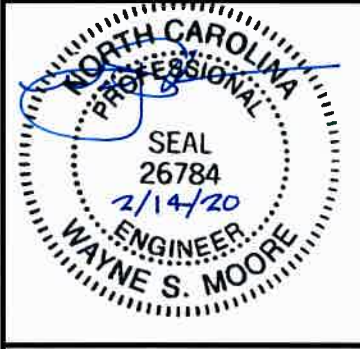



STEEL BUILDINGS AND STRUCTURES, INC.
P.O. BOX 1287,
MOUNT AIRY, NC 27030
30'-0"x20'-0" ENCLOSED STRUCTURE

THIS DOCUMENT IS THE PROPERTY OF MOORE AND ASSOCIATES ENGINEERING AND CONSULTING. THE UNAUTHORIZED REPRODUCTION, COPYING, OR OTHERWISE USE OF THIS DOCUMENT IS STRICTLY PROHIBITED AND ANY INFRINGEMENT THEREUPON MAY BE SUBJECT TO LEGAL ACTION.

PROJECT MGR: WSM
CLIENT: SBSI

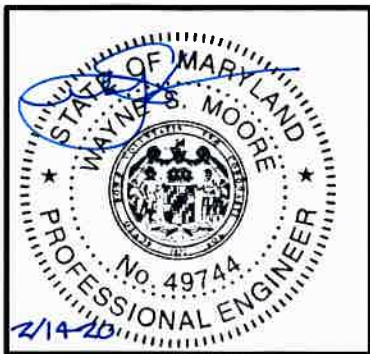
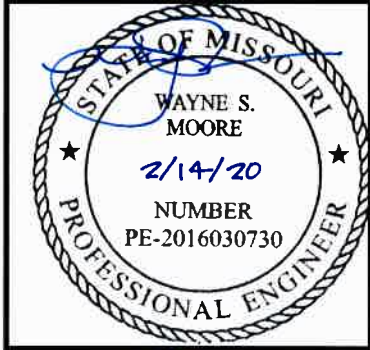
DATE: 2-14-20
SHT. 1

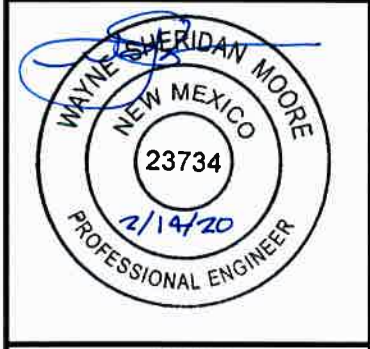
SCALE: NTS
JOB NO: 18068S
18156S/18290S/20019S
DWG. NO: SK-3
REV: 8

	Professional Certification. I hereby certify that these documents were prepared or approved by me, and that I am a duly licensed professional engineer under the laws of the State of Maryland, License No. 49744, Expiration Date <u>2/14/20</u>		
			
			
			
			

MOORE AND ASSOCIATES ENGINEERING AND CONSULTING, INC.	DRAWN BY: LT	STEEL BUILDINGS AND STRUCTURES, INC. P.O. BOX 1287, MOUNT AIRY, NC 27030 30'-0"x20'-0" ENCLOSED STRUCTURE		
	CHECKED BY: PDH			
<small>THIS DOCUMENT IS THE PROPERTY OF MOORE AND ASSOCIATES ENGINEERING AND CONSULTING. THE UNAUTHORIZED REPRODUCTION, COPYING, OR OTHERWISE USE OF THIS DOCUMENT IS STRICTLY PROHIBITED AND ANY INFRINGEMENT THEREUPON MAY BE SUBJECT TO LEGAL ACTION.</small>	PROJECT MGR: WSM	DATE: 2-14-20	SCALE: NTS	JOB NO: 18068S 18156S/18290S/20019S
	CLIENT: SBSI	SHT. 1A	DWG. NO SK-3	REV: 8

DRAWING INDEX

SHEET 1	PE SEAL COVER SHEET (1 OF 2)
SHEET 1A	PE SEAL COVER SHEET (2 OF 2)
SHEET 2	DRAWING INDEX
SHEET 3	INSTALLATION NOTES AND SPECIFICATIONS
SHEET 4	TYPICAL SIDE AND END ELEVATIONS
SHEET 5	TYPICAL RAFTER/COLUMN FRAME AND SIDE FRAMING SECTION (BOX EAVE STRUCTURE)
SHEET 5A	TYPICAL RAFTER/COLUMN FRAME AND SIDE FRAMING SECTION (BOX EAVE STRUCTURE)
SHEET 5B	TYPICAL RAFTER/COLUMN FRAME AND SIDE FRAMING SECTION (BOX EAVE STRUCTURE)
SHEET 6	COLUMN CONNECTION DETAILS (BOX EAVE STRUCTURE)
SHEET 6A	COLUMN CONNECTION DETAILS (BOX EAVE STRUCTURE)
SHEET 7	TYPICAL RAFTER/COLUMN FRAME AND SIDE FRAMING SECTION (BOW EAVE STRUCTURE)
SHEET 7A	TYPICAL RAFTER/COLUMN FRAME AND SIDE FRAMING SECTION (BOW EAVE STRUCTURE)
SHEET 7B	TYPICAL RAFTER/COLUMN FRAME AND SIDE FRAMING SECTION (BOW EAVE STRUCTURE)
SHEET 8	COLUMN CONNECTION DETAILS (BOW EAVE STRUCTURE)
SHEET 8A	COLUMN CONNECTION DETAILS (BOW EAVE STRUCTURE)
SHEET 9	BASE RAIL ANCHORAGE OPTIONS
SHEET 9A	ADDITIONAL BASE RAIL ANCHORAGE OPTION
SHEET 10	BOX EAVE RAFTER END WALL AND SIDE WALL OPENINGS
SHEET 11	BOW EAVE RAFTER END WALL AND SIDE WALL OPENINGS
SHEET 12	CONNECTION DETAILS
SHEET 13	CONNECTION DETAILS
SHEET 14	BOX EAVE RAFTER LEAN-TO OPTIONS
SHEET 15	BOW EAVE RAFTER LEAN-TO OPTIONS
SHEET 16	VERTICAL ROOF/SIDING OPTION END AND SIDE ELEVATION AND SECTION
SHEET 17	SIDE WALL AND END WALL HEADER OPTIONS
SHEET 18	OPTIONAL BASE RAIL ON GRADE APPLICATION
SHEET 19	OPTIONAL BASE RAIL ON TIMBER BEAM
SHEET 20	OPTIONAL BASE RAIL ON TIMBER BEAM WITH SOIL NAIL
SHEET 21	OPTIONAL CONCRETE STRIP FOOTING

**MOORE AND ASSOCIATES
ENGINEERING AND CONSULTING, INC.**

DRAWN BY: LT

CHECKED BY: PDH

PROJECT MGR: WSM

CLIENT: SBSI

STEEL BUILDINGS AND STRUCTURES, INC.
P.O. BOX 1287,
MOUNT AIRY, NC 27030
30'-0" x 20'-0" ENCLOSED STRUCTURE

DATE: 2-14-20

SCALE: NTS

SHT. 2

DWG. NO: SK-3

**JOB NO: 18068S
18156S/18290S/20019S**

REV: 8

THIS DOCUMENT IS THE PROPERTY OF MOORE AND ASSOCIATES ENGINEERING AND CONSULTING. THE UNAUTHORIZED REPRODUCTION, COPYING, OR OTHERWISE USE OF THIS DOCUMENT IS STRICTLY PROHIBITED AND ANY INFRINGEMENT THEREUPON MAY BE SUBJECT TO LEGAL ACTION.

INSTALLATION NOTES AND SPECIFICATIONS

1. DESIGN IS FOR MAXIMUM 30'-0" WIDE x 20'-0" EAVE HEIGHT ENCLOSED STRUCTURES.
2. DESIGN WAS DONE IN ACCORDANCE WITH THE 2017 FLORIDA BUILDING CODE (FBC) 6TH EDITION, 2018 NORTH CAROLINA BUILDING CODE, 2006 INTERNATIONAL BUILDING CODE (IBC), 2009 IBC, 2012 IBC, 2015 IBC AND 2018 IBC.
3. DESIGN LOADS ARE AS FOLLOWS:
 - A) DEAD LOAD = 1.5 PSF
 - B) LIVE LOAD = 12 PSF
 - C) GROUND SNOW LOAD = 30 PSF (< 26'-0"), 35 PSF (26'-0" < W < 30'-0")
NOTE: (UNBALANCED SNOW LOADS DUE TO DRIFTING HAVE NOT BEEN EVALUATED)
4. 3-SECOND GUST ULTIMATE WIND SPEED (V_{ULT}) = 105 TO 145 MPH (NOMINAL WIND SPEED = 82 TO 112 MPH)
5. MAXIMUM RAFTER/COLUMN AND END COLUMN SPACING = 50 FEET (UNLESS NOTED OTHERWISE).
6. END WALL COLUMNS (POSTS) ARE EQUIVALENT TO SIDE WALL POSTS IN SIZE AND SPACING (UNLESS NOTED OTHERWISE).
7. RISK CATEGORY I.
8. WIND EXPOSURE CATEGORY B
9. SPECIFICATIONS APPLICABLE TO 29 GAUGE METAL PANELS FASTENED DIRECTLY TO 2 1/2" x 2 1/2" - 14 GAUGE TUBE STEEL (TS) FRAMING MEMBERS (UNLESS NOTED OTHERWISE).
10. AVERAGE FASTENER SPACING ON-CENTERS ALONG RAFTERS OR HAT CHANNELS, AND COLUMNS (INTERIOR OR END) = 8 INCHES.
11. FASTENERS CONSIST OF 1/4"x3/4" SELF-DRILLING FASTENER (SDF), USE CONTROL SEAL WASHER WITH EXTERIOR FASTENERS. SPECIFICATIONS APPLICABLE ONLY FOR MEAN ROOF HEIGHT OF 20 FEET OR LESS, AND ROOF SLOPES OF 14° (3:12 PITCH) OR LESS. SPACING REQUIREMENTS FOR OTHER ROOF HEIGHTS AND/OR SLOPES MAY VARY. ROOF SLOPES LESS THAN 3:12 REQUIRE USE OF LAP JOINT SEALANT.
12. GROUND ANCHORS SHALL BE INSTALLED THROUGH BASE RAIL WITHIN 6" OF EACH COLUMN.
13. STANDARD GROUND ANCHORS (SOIL NAILS) CONSIST OF #4 REBAR W/ WELDED NUT x 36" LONG AND MAY BE USED IN SUITABLE SOILS. OPTIONAL ANCHORAGE MAY BE USED IN SUITABLE SOILS AND MUST BE USED IN UNSUITABLE SOILS AS NOTED.
14. WIND FORCES GOVERN OVER SEISMIC FORCES. SEISMIC PARAMETERS ANALYZED ARE:
 - SOIL SITE CLASS = D
 - RISK CATEGORY I
 - R = 325 $I_E = 10$
 - $S_{DS} = 2039 g$ $V = C_S W$
 - $S_{DI} = 1258 g$
15. WINDOW AND DOOR DESIGN PRESSURES ARE APPLICABLE TO THE STATE OF FLORIDA ONLY

**MOORE AND ASSOCIATES
ENGINEERING AND CONSULTING, INC.**

DRAWN BY: LT

CHECKED BY: PDH

PROJECT MGR: WSM

CLIENT: SBSI

STEEL BUILDINGS AND STRUCTURES, INC.

P.O. BOX 1287,
MOUNT AIRY, NC 27030
30'-0"x20'-0" ENCLOSED STRUCTURE

DATE: 2-14-20

SCALE: NTS

**JOB NO: 18068S
18156S/18290S/20019S**

SHT. 3

DWG. NO: SK-3

REV: 8

THIS DOCUMENT IS THE PROPERTY OF MOORE AND ASSOCIATES ENGINEERING AND CONSULTING. THE UNAUTHORIZED REPRODUCTION, COPYING, OR OTHERWISE USE OF THIS DOCUMENT IS STRICTLY PROHIBITED AND ANY INFRINGEMENT THEREUPON MAY BE SUBJECT TO LEGAL ACTION.

BOX EAVE FRAME RAFTER STRUCTURE

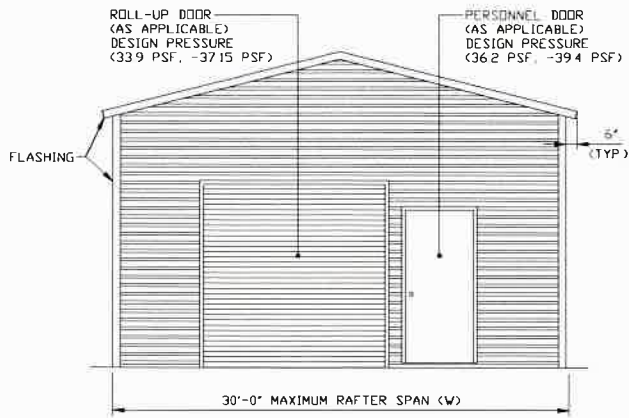

TYPICAL END ELEVATION

SCALE: NTS

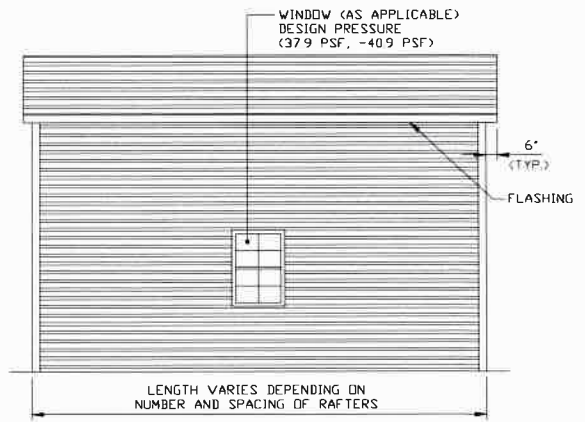

TYPICAL SIDE ELEVATION

SCALE: NTS

BOW EAVE FRAME RAFTER STRUCTURE

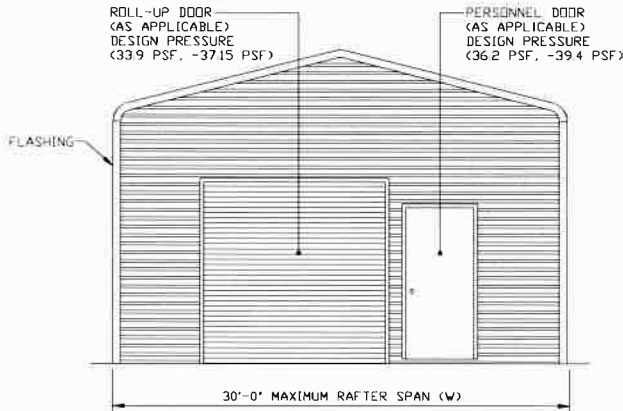

TYPICAL END ELEVATION

SCALE: NTS

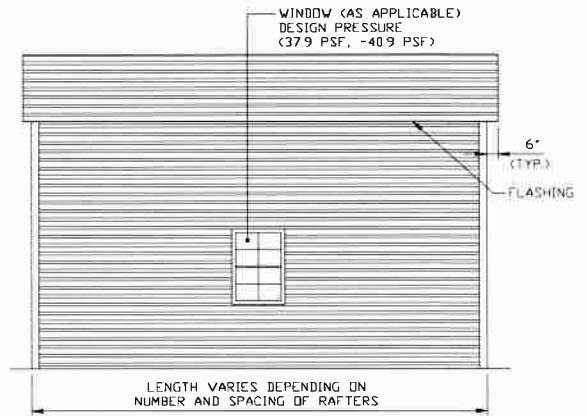

TYPICAL SIDE ELEVATION

SCALE: NTS

**MOORE AND ASSOCIATES
ENGINEERING AND CONSULTING, INC.**

DRAWN BY: LT

CHECKED BY: PDH

PROJECT MGR: WSM

CLIENT: SBSI

STEEL BUILDINGS AND STRUCTURES, INC.
P.O. BOX 1287,
MOUNT AIRY, NC 27030
30'-0"x20'-0" ENCLOSED STRUCTURE

DATE: 2-14-20

SCALE: NTS

SHT. 4

DWG. NO: SK-3

JOB NO: 18068S

18156S/18290S/20019S

REV: 8

THIS DOCUMENT IS THE PROPERTY OF MOORE AND ASSOCIATES ENGINEERING AND CONSULTING. THE UNAUTHORIZED REPRODUCTION, COPYING, OR OTHERWISE USE OF THIS DOCUMENT IS STRICTLY PROHIBITED AND ANY INFRINGEMENT THEREUPON MAY BE SUBJECT TO LEGAL ACTION.

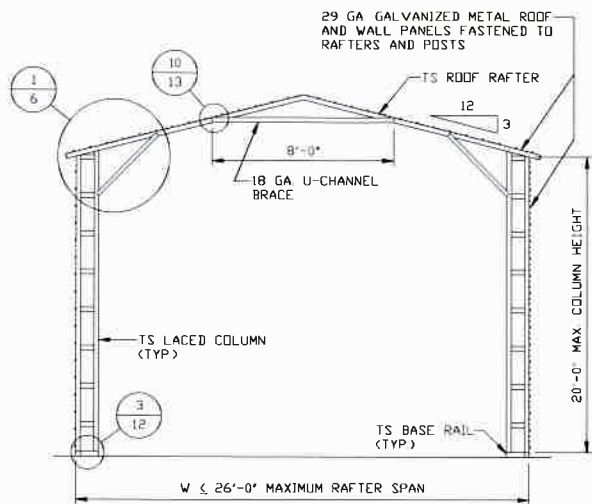

TYPICAL RAFTER/COLUMN FRAME SECTION
SCALE: NTS

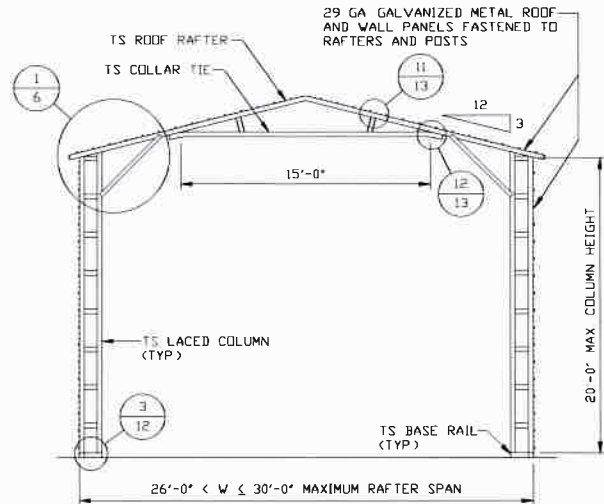

TYPICAL RAFTER/COLUMN FRAME SECTION
SCALE: NTS

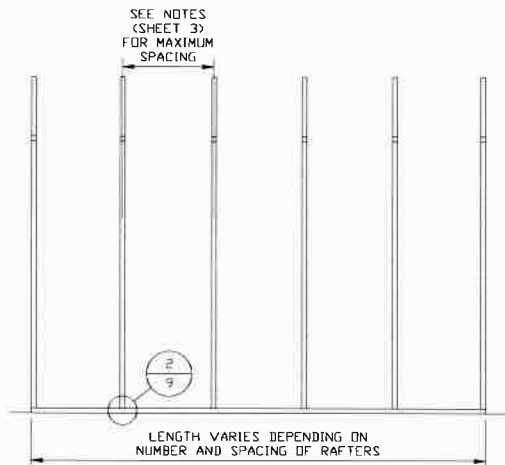

TYPICAL RAFTER/COLUMN SIDE FRAMING SECTION
SCALE: NTS

**MOORE AND ASSOCIATES
ENGINEERING AND CONSULTING, INC.**

DRAWN BY: LT

CHECKED BY: PDH

PROJECT MGR: WSM

CLIENT: SBSI

STEEL BUILDINGS AND STRUCTURES, INC.
P.O. BOX 1287,
MOUNT AIRY, NC 27030
30'-0"x20'-0" ENCLOSED STRUCTURE

DATE: 2-14-20

SHT. 5

SCALE: NTS

DWG. NO: SK-3

**JOB NO: 18068S
18156S/18290S/20019S**

REV: 8

THIS DOCUMENT IS THE PROPERTY OF MOORE AND ASSOCIATES ENGINEERING AND CONSULTING. THE UNAUTHORIZED REPRODUCTION, COPYING, OR OTHERWISE USE OF THIS DOCUMENT IS STRICTLY PROHIBITED AND ANY INFRINGEMENT THEREUPON MAY BE SUBJECT TO LEGAL ACTION.

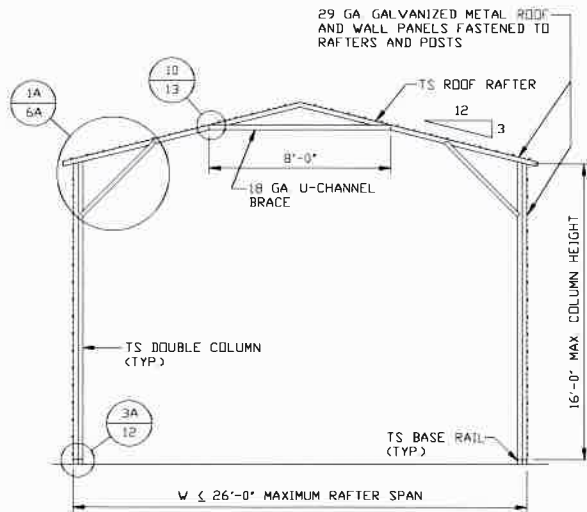

TYPICAL RAFTER/COLUMN FRAME SECTION
SCALE: NTS

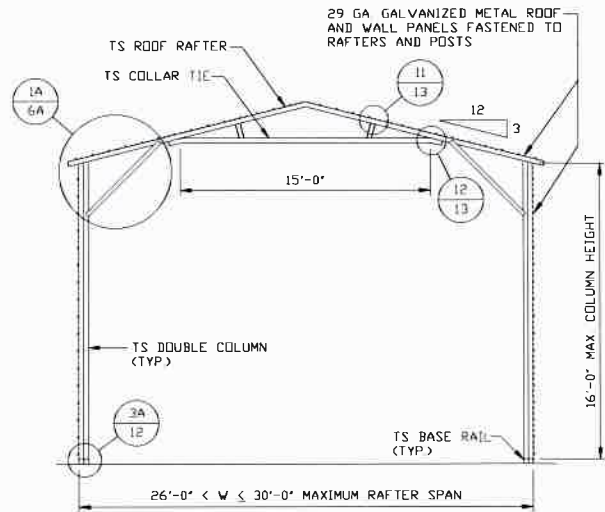

TYPICAL RAFTER/COLUMN FRAME SECTION
SCALE: NTS

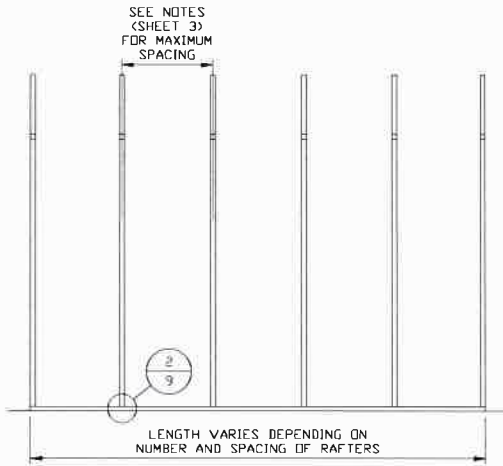

TYPICAL RAFTER/COLUMN SIDE FRAMING SECTION
SCALE: NTS

**MOORE AND ASSOCIATES
ENGINEERING AND CONSULTING, INC.**

DRAWN BY: LT

CHECKED BY: PDH

PROJECT MGR: WSM

CLIENT: SBSI

STEEL BUILDINGS AND STRUCTURES, INC.
P.O. BOX 1287,
MOUNT AIRY, NC 27030
30'-0" x 20'-0" ENCLOSED STRUCTURE

DATE: 2-14-20

SHT. 5A

SCALE: NTS

DWG. NO: SK-3

**JOB NO: 18068S
18156S/18290S/20019S**

REV: 8

THIS DOCUMENT IS THE PROPERTY OF MOORE AND ASSOCIATES ENGINEERING AND CONSULTING. THE UNAUTHORIZED REPRODUCTION, COPYING, OR OTHERWISE USE OF THIS DOCUMENT IS STRICTLY PROHIBITED AND ANY INFRINGEMENT THEREUPON MAY BE SUBJECT TO LEGAL ACTION.

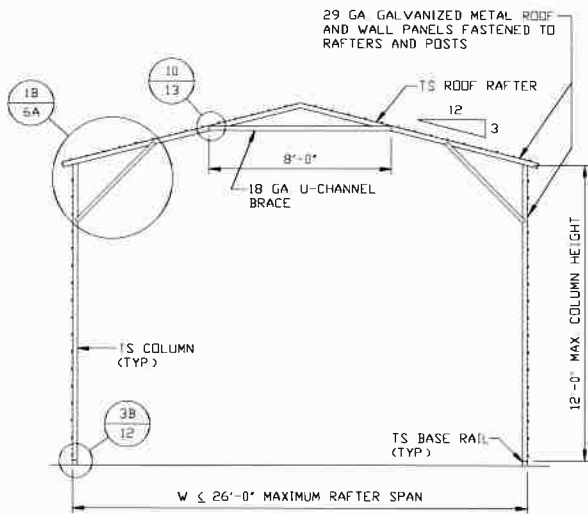

TYPICAL RAFTER/COLUMN FRAME SECTION

SCALE: NTS

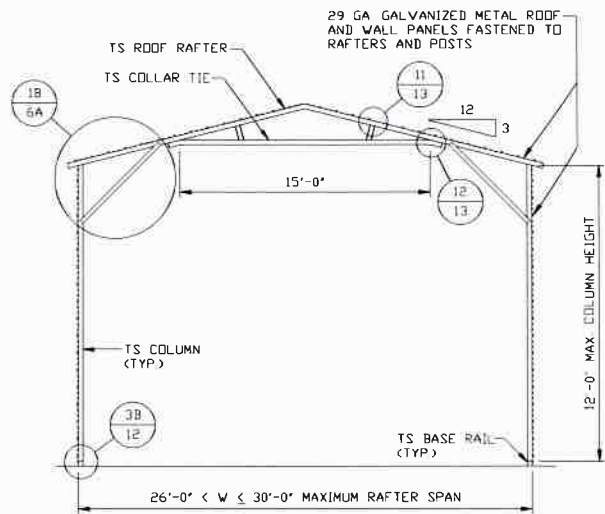

TYPICAL RAFTER/COLUMN FRAME SECTION

SCALE: NTS

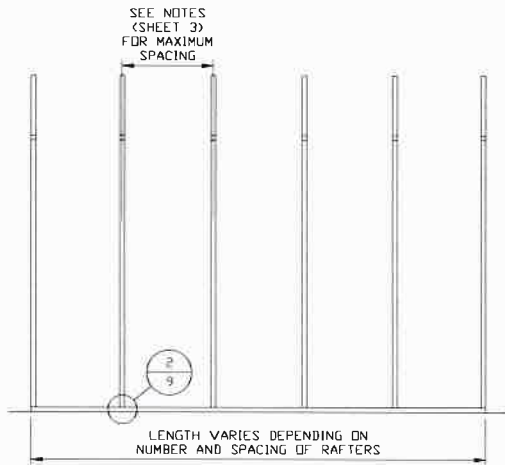

TYPICAL RAFTER/COLUMN SIDE FRAMING SECTION

SCALE: NTS

**MOORE AND ASSOCIATES
ENGINEERING AND CONSULTING, INC.**

DRAWN BY: LT

CHECKED BY: PDH

PROJECT MGR: WSM

CLIENT: SBSI

STEEL BUILDINGS AND STRUCTURES, INC.
P.O. BOX 1287,
MOUNT AIRY, NC 27030
30'-0" x 20'-0" ENCLOSED STRUCTURE

DATE: 2-14-20

SCALE: NTS

SHT. 5B

DWG. NO: SK-3

**JOB NO: 18068S
18156S/18290S/20019S**

REV: 0

THIS DOCUMENT IS THE PROPERTY OF MOORE AND ASSOCIATES ENGINEERING AND CONSULTING. THE UNAUTHORIZED REPRODUCTION, COPYING, OR OTHERWISE USE OF THIS DOCUMENT IS STRICTLY PROHIBITED AND ANY INFRINGEMENT THEREUPON MAY BE SUBJECT TO LEGAL ACTION.

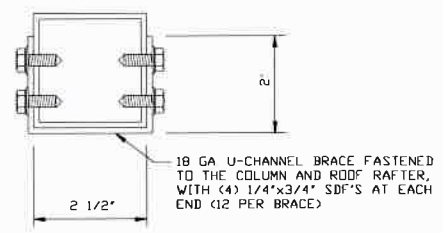
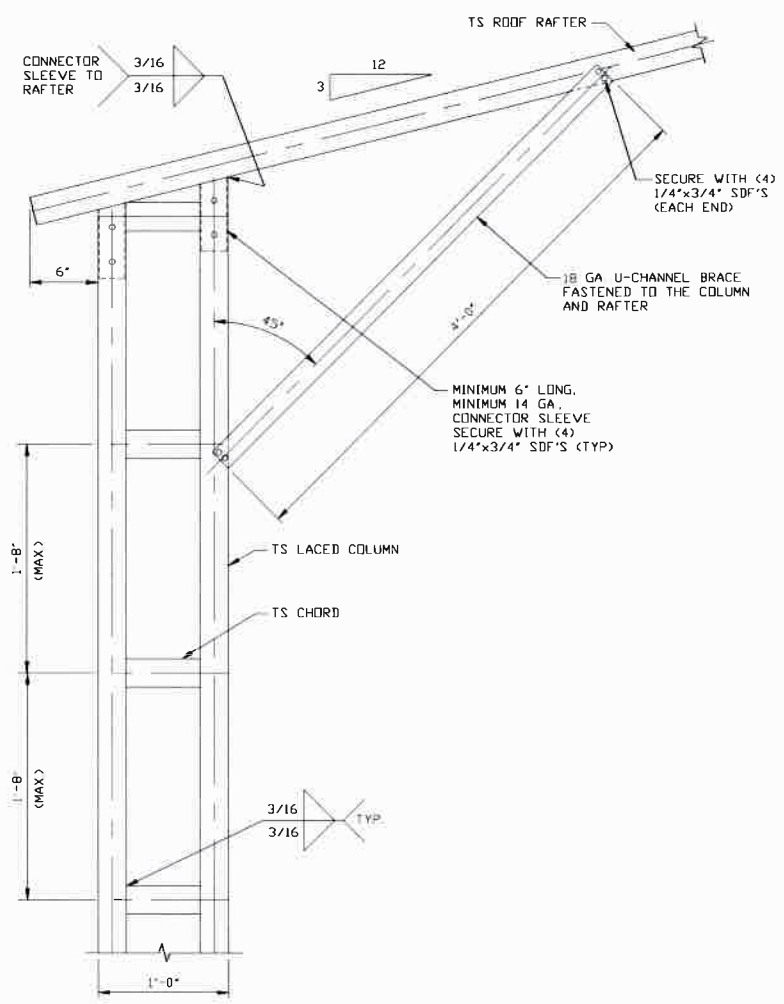

BRACE SECTION
SCALE: NTS

1
BOX EAVE RAFTER/CORNER POST CONNECTION DETAIL
FOR HEIGHTS 16'-0" < TO ≤ 20'-0"
SCALE: NTS

MOORE AND ASSOCIATES ENGINEERING AND CONSULTING, INC.	DRAWN BY: LT	STEEL BUILDINGS AND STRUCTURES, INC. P.O. BOX 1287, MOUNT AIRY, NC 27030 30'-0" x 20'-0" ENCLOSED STRUCTURE		
	CHECKED BY: PDH			
THIS DOCUMENT IS THE PROPERTY OF MOORE AND ASSOCIATES ENGINEERING AND CONSULTING. THE UNAUTHORIZED REPRODUCTION, COPYING, OR OTHERWISE USE OF THIS DOCUMENT IS STRICTLY PROHIBITED AND ANY INFRINGEMENT THEREUPON MAY BE SUBJECT TO LEGAL ACTION.	PROJECT MGR: WSM	DATE: 2-14-20	SCALE: NTS	JOB NO: 18068S 18156S/18290S/20019S
	CLIENT: SBSI	SHT. 6	DWG. NO: SK-3	REV: 8

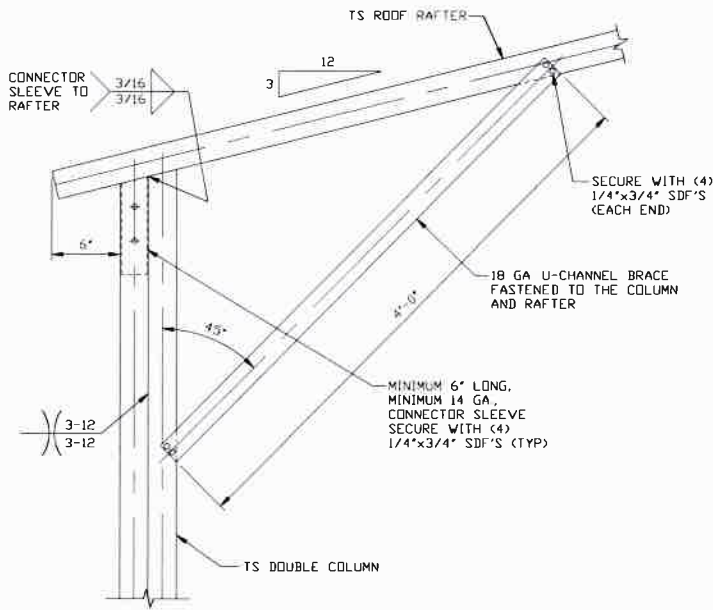

BOX EAVE RAFTER/CORNER POST CONNECTION DETAIL FOR HEIGHTS 12'-0" < TO ≤ 16'-0"

1A

SCALE: NTS

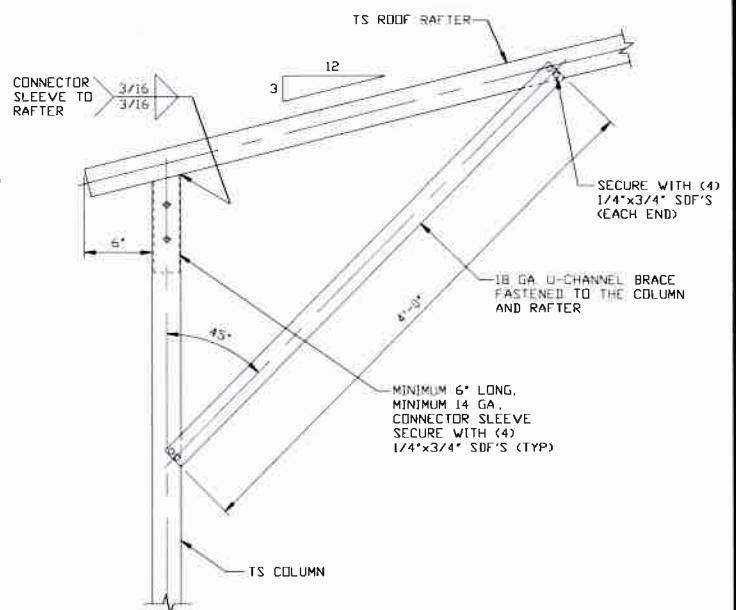

BOX EAVE RAFTER/CORNER POST CONNECTION DETAIL FOR HEIGHTS ≤ 12'-0"

1B

SCALE: NTS

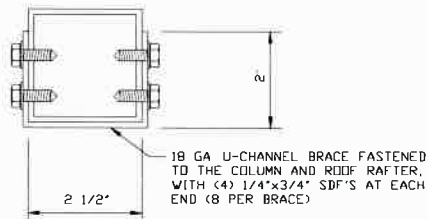

BRACE SECTION

SCALE: NTS

**MOORE AND ASSOCIATES
ENGINEERING AND CONSULTING, INC.**

DRAWN BY: LT

CHECKED BY: PDH

PROJECT MGR: WSM

CLIENT: SBSI

STEEL BUILDINGS AND STRUCTURES, INC.
P.O. BOX 1287,
MOUNT AIRY, NC 27030
30'-0" x 20'-0" ENCLOSED STRUCTURE

DATE: 2-14-20

SHT. 6A

SCALE: NTS

DWG. NO: SK-3

JOB NO: 18068S

18156S/18290S/20019S

REV: 8

THIS DOCUMENT IS THE PROPERTY OF MOORE AND ASSOCIATES ENGINEERING AND CONSULTING. THE UNAUTHORIZED REPRODUCTION, COPYING, OR OTHERWISE USE OF THIS DOCUMENT IS STRICTLY PROHIBITED AND ANY INFRINGEMENT THEREUPON MAY BE SUBJECT TO LEGAL ACTION.

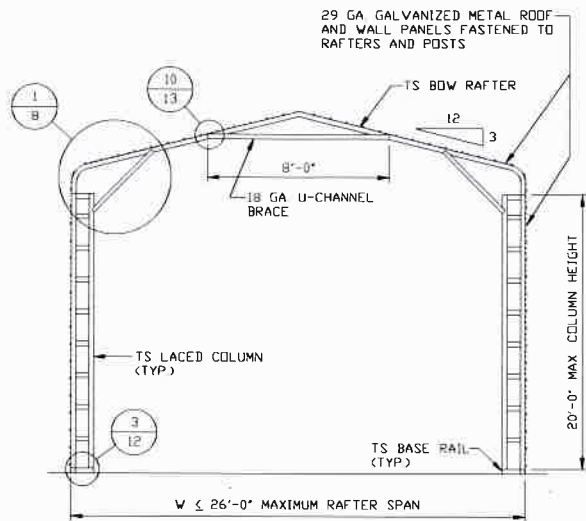

TYPICAL RAFTER/COLUMN FRAME SECTION
SCALE: NTS

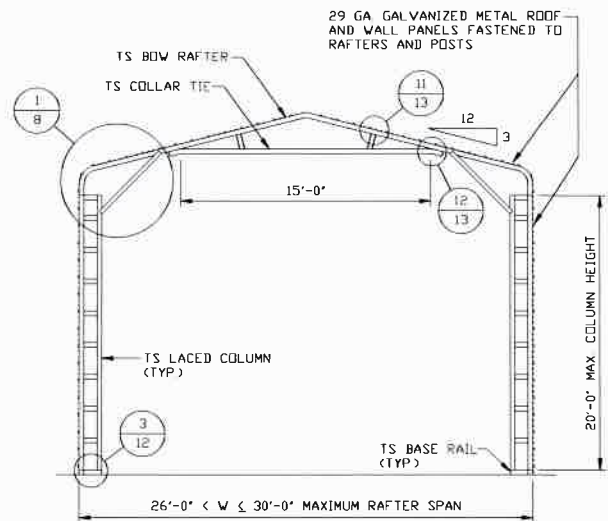

TYPICAL RAFTER/COLUMN FRAME SECTION
SCALE: NTS

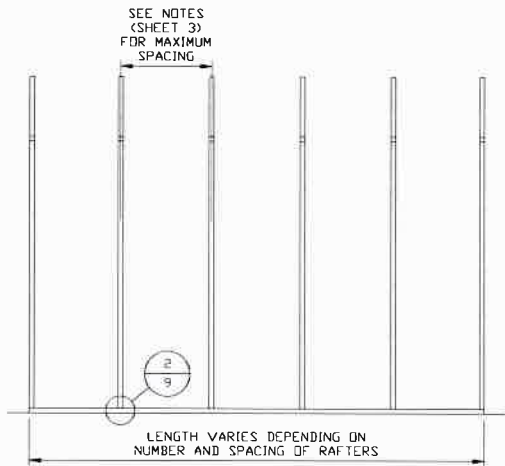

TYPICAL RAFTER/COLUMN SIDE FRAMING SECTION
SCALE: NTS

**MOORE AND ASSOCIATES
ENGINEERING AND CONSULTING, INC.**

DRAWN BY: LT

CHECKED BY: PDH

PROJECT MGR: WSM

CLIENT: SBSI

STEEL BUILDINGS AND STRUCTURES, INC.
P.O. BOX 1287,
MOUNT AIRY, NC 27030
30'-0"x20'-0" ENCLOSED STRUCTURE

DATE: 2-14-20

SHT. 7

SCALE: NTS

DWG. NO: SK-3

**JOB NO: 18068S
18156S/18290S/20019S**

REV: 8

THIS DOCUMENT IS THE PROPERTY OF MOORE AND ASSOCIATES ENGINEERING AND CONSULTING. THE UNAUTHORIZED REPRODUCTION, COPYING, OR OTHERWISE USE OF THIS DOCUMENT IS STRICTLY PROHIBITED AND ANY INFRINGEMENT THEREUPON MAY BE SUBJECT TO LEGAL ACTION.

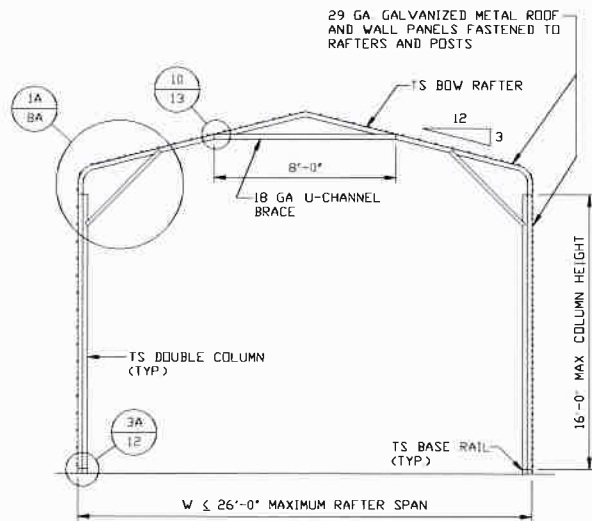

TYPICAL RAFTER/COLUMN FRAME SECTION
SCALE: NTS

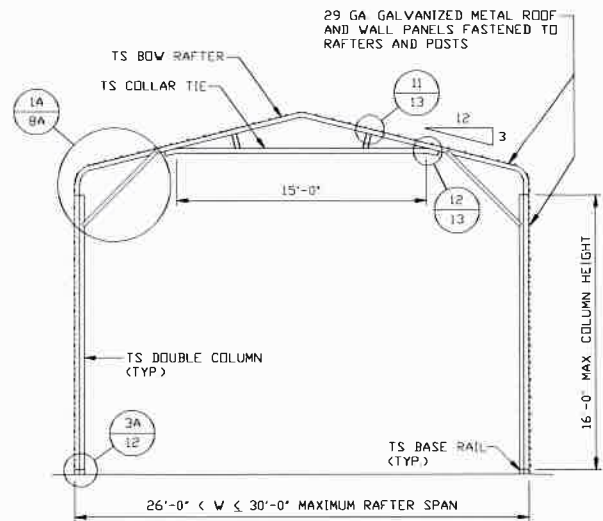

TYPICAL RAFTER/COLUMN FRAME SECTION
SCALE: NTS

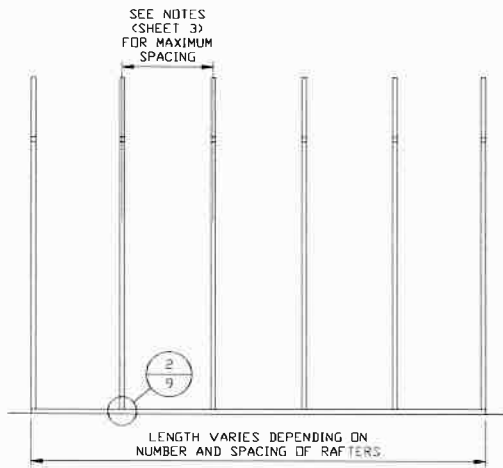

TYPICAL RAFTER/COLUMN SIDE FRAMING SECTION
SCALE: NTS

**MOORE AND ASSOCIATES
ENGINEERING AND CONSULTING, INC.**

DRAWN BY: LT

CHECKED BY: PDH

PROJECT MGR: WSH

CLIENT: SBSI

STEEL BUILDINGS AND STRUCTURES, INC.
P.O. BOX 1287,
MOUNT AIRY, NC 27030
30'-0" x 20'-0" ENCLOSED STRUCTURE

DATE: 2-14-20

SHT. 7A

SCALE: NTS

DWG. NO: SK-3

JOB NO: 18068S
18156S/18290S/20019S

REV: 8

THIS DOCUMENT IS THE PROPERTY OF MOORE AND ASSOCIATES ENGINEERING AND CONSULTING. THE UNAUTHORIZED REPRODUCTION, COPYING, OR OTHERWISE USE OF THIS DOCUMENT IS STRICTLY PROHIBITED AND ANY INFRINGEMENT THEREUPON MAY BE SUBJECT TO LEGAL ACTION.

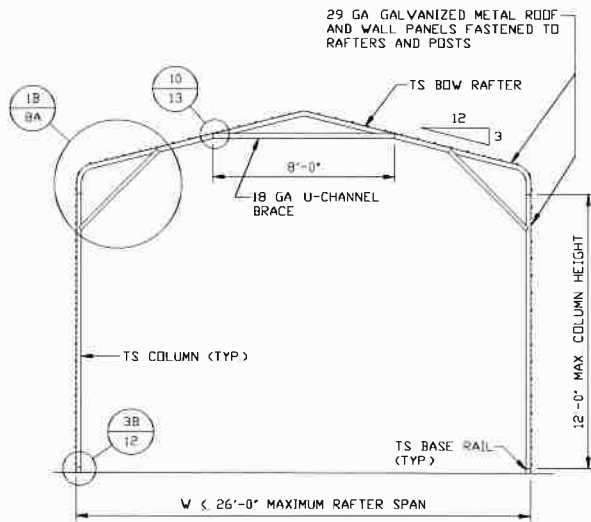

TYPICAL RAFTER/COLUMN FRAME SECTION

SCALE: NTS

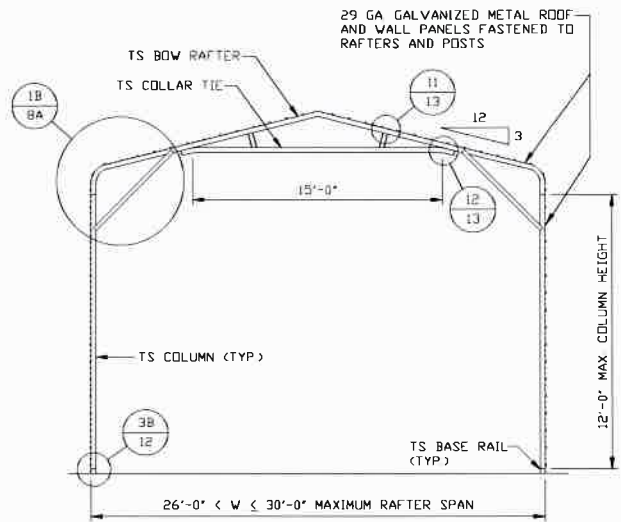

TYPICAL RAFTER/COLUMN FRAME SECTION

SCALE: NTS

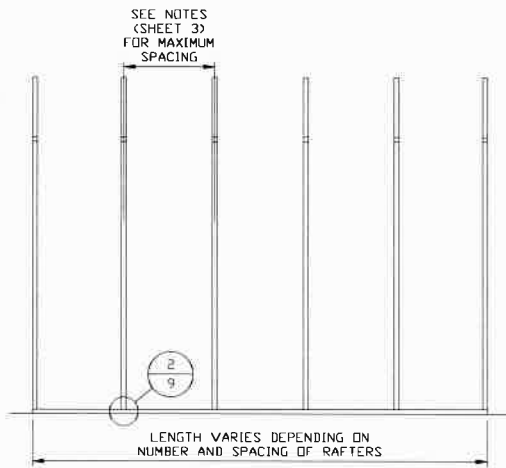

TYPICAL RAFTER/COLUMN SIDE FRAMING SECTION

SCALE: NTS

**MOORE AND ASSOCIATES
ENGINEERING AND CONSULTING, INC.**

DRAWN BY: LT

CHECKED BY: PDH

PROJECT MGR: WSM

CLIENT: SBSI

STEEL BUILDINGS AND STRUCTURES, INC.
P.O. BOX 1287,
MOUNT AIRY, NC 27030
30'-0" x 20'-0" ENCLOSED STRUCTURE

DATE: 2-14-20

SHT. 7B

SCALE: NTS

DWG. NO: SK-3

**JOB NO: 18068S
18156S/18290S/20019S**

REV: 8

THIS DOCUMENT IS THE PROPERTY OF MOORE AND ASSOCIATES ENGINEERING AND CONSULTING. THE UNAUTHORIZED REPRODUCTION, COPYING, OR OTHERWISE USE OF THIS DOCUMENT IS STRICTLY PROHIBITED AND ANY INFRINGEMENT THEREUPON MAY BE SUBJECT TO LEGAL ACTION.

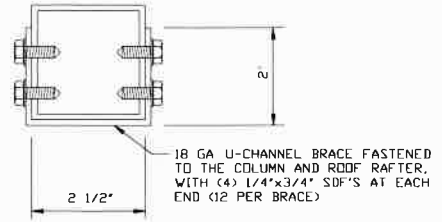
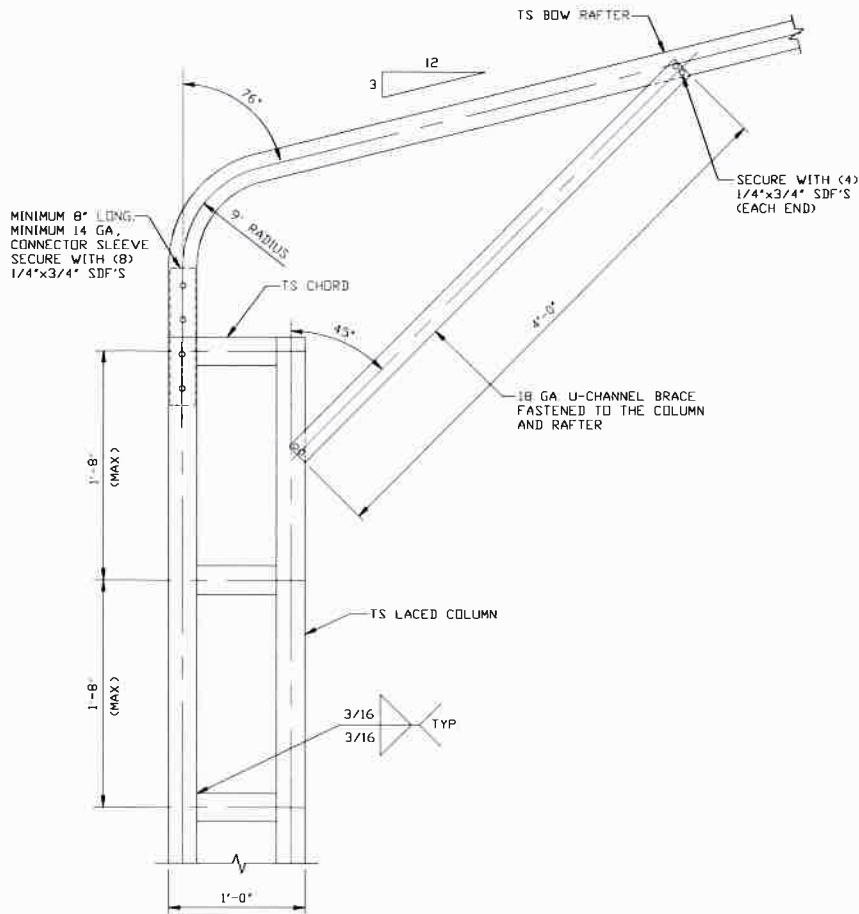

BOX EAVE RAFTER/CORNER POST CONNECTION DETAIL
FOR HEIGHTS 16'-0" < TO ≤ 20'-0"
 SCALE: NTS.

1

MOORE AND ASSOCIATES ENGINEERING AND CONSULTING, INC.	DRAWN BY: LT	STEEL BUILDINGS AND STRUCTURES, INC. P.O. BOX 1287, MOUNT AIRY, NC 27030 30'-0"x20'-0" ENCLOSED STRUCTURE		
	CHECKED BY: PDH			
<small>THIS DOCUMENT IS THE PROPERTY OF MOORE AND ASSOCIATES ENGINEERING AND CONSULTING. THE UNAUTHORIZED REPRODUCTION, COPYING, OR OTHERWISE USE OF THIS DOCUMENT IS STRICTLY PROHIBITED AND ANY INFRINGEMENT THEREUPON MAY BE SUBJECT TO LEGAL ACTION.</small>	PROJECT MGR: VSM	DATE: 2-14-20	SCALE: NTS	JOB NO: 18068S 18156S/18290S/20019S
	CLIENT: SBSI	SHT. 8	DWG. NO: SK-3	REV: 8

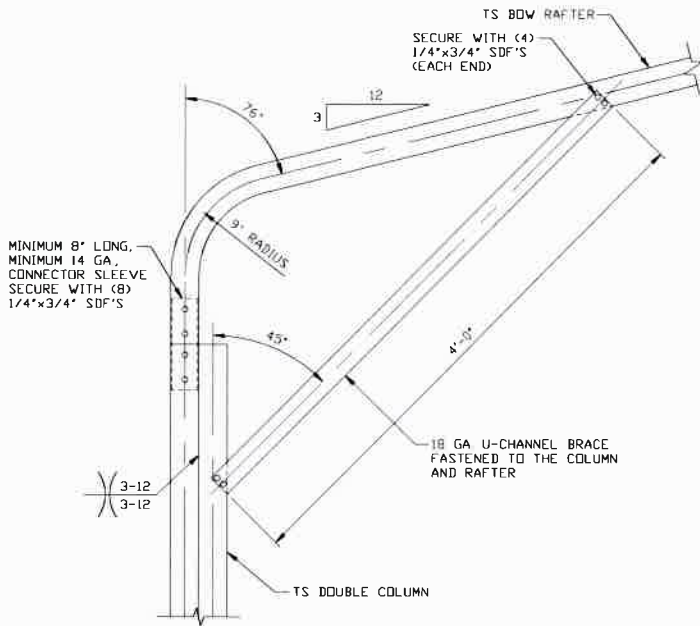

BOX EAVE RAFTER/CORNER POST CONNECTION DETAIL FOR HEIGHTS 12'-0" < TO ≤ 16'-0"

1A

SCALE: NTS

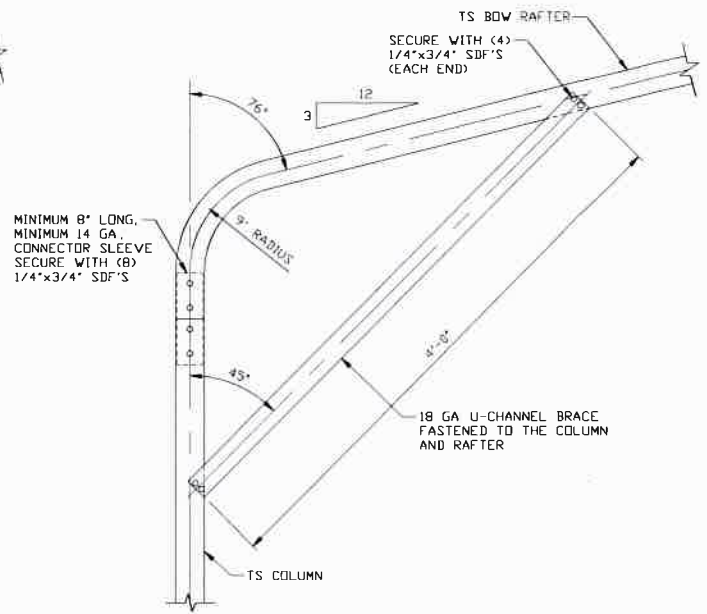

BOX EAVE RAFTER/CORNER POST CONNECTION DETAIL FOR HEIGHTS ≤ 12'-0"

1B

SCALE: NTS

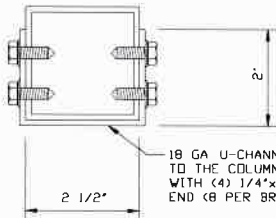

18 GA U-CHANNEL BRACE FASTENED TO THE COLUMN AND ROOF RAFTER, WITH (4) 1/4" x 3/4" SDF'S AT EACH END (8 PER BRACE)

BRACE SECTION

SCALE: NTS

**MOORE AND ASSOCIATES
ENGINEERING AND CONSULTING, INC.**

DRAWN BY: LT

CHECKED BY: PDH

PROJECT MGR: WSM

CLIENT: SBSI

STEEL BUILDINGS AND STRUCTURES, INC.
P.O. BOX 1287,
MOUNT AIRY, NC 27030
30'-0" x 20'-0" ENCLOSED STRUCTURE

DATE: 2-14-20

SHT. 8A

SCALE: NTS

DWG. NO: SK-3

JOB NO: 18068S

18156S/18290S/20019S

REV: 8

THIS DOCUMENT IS THE PROPERTY OF MOORE AND ASSOCIATES ENGINEERING AND CONSULTING. THE UNAUTHORIZED REPRODUCTION, COPYING, OR OTHERWISE USE OF THIS DOCUMENT IS STRICTLY PROHIBITED AND ANY INFRINGEMENT THEREUPON MAY BE SUBJECT TO LEGAL ACTION.

BASE RAIL ANCHORAGE OPTIONS

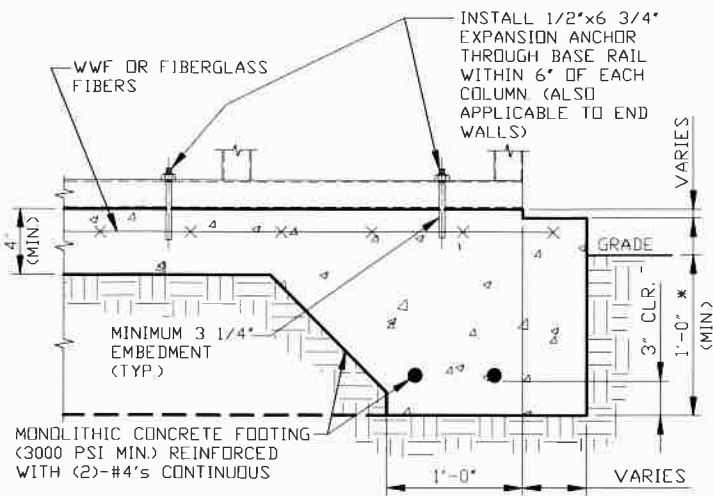

**2 CONCRETE MONOLITHIC SLAB
BASE RAIL ANCHORAGE**
SCALE: NTS
MINIMUM ANCHOR EDGE DISTANCE IS 4"
* COORDINATE WITH LOCAL CODES/ORD.

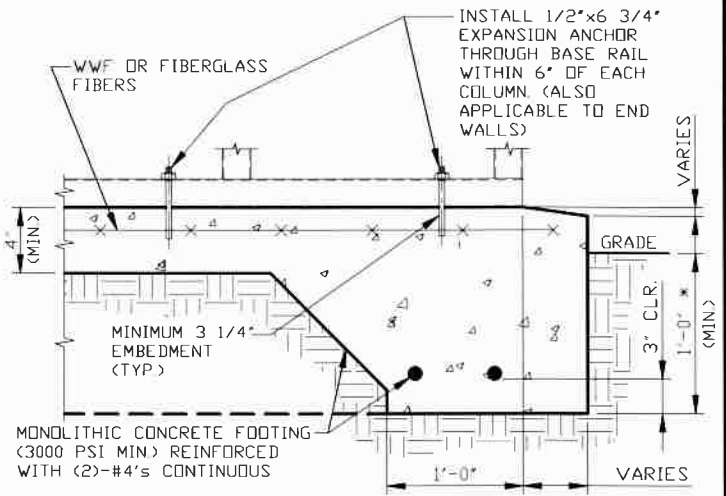

**2A CONCRETE SLAB BASE
RAIL ANCHORAGE**
SCALE: NTS
MINIMUM ANCHOR EDGE DISTANCE IS 4"
* COORDINATE WITH LOCAL CODES/ORD.

GENERAL NOTES

NOTE: CONCRETE MONOLITHIC SLAB DESIGN BASED ON MINIMUM SOIL BEARING CAPACITY OF 1,500 PSF.

CONCRETE:

CONCRETE SHALL HAVE A MINIMUM SPECIFIED COMPRESSIVE STRENGTH OF 3,000 PSI AT 28 DAYS.

COVER OVER REINFORCING STEEL:

FOR FOUNDATIONS, MINIMUM CONCRETE COVER OVER REINFORCING BARS SHALL BE PER ACI-318:
3" IN FOUNDATIONS WHERE THE CONCRETE IS CAST AGAINST AND PERMANENTLY IN CONTACT WITH THE EARTH OR EXPOSED TO THE EARTH OR WEATHER, AND 1 1/2" ELSEWHERE.

REINFORCING STEEL:

THE TURNDOWN REINFORCING STEEL SHALL BE ASTM A615 GRADE 60. THE SLAB REINFORCEMENT SHALL BE WELDED WIRE FABRIC MEETING ASTM A185 OR FIBERGLASS FIBER REINFORCEMENT.

REINFORCEMENT MAY BE BENT IN THE SHOP OR THE FIELD PROVIDED:

1. REINFORCEMENT IS BENT COLD.
2. THE DIAMETER OF THE BEND, MEASURED ON THE INSIDE OF THE BAR, IS NOT LESS THAN SIX-BAR DIAMETERS.
3. REINFORCEMENT PARTIALLY EMBEDDED IN CONCRETE SHALL NOT BE FIELD BENT.

HELIX ANCHOR NOTES:

1. FOR VERY DENSE AND/OR CEMENTED SANDS, COARSE GRAVEL AND COBBLES, CALICHE, PRELOADED SILTS AND CLAYS, USE MINIMUM (2) 4" HELICES WITH MINIMUM 30" EMBEDMENT OR SINGLE 6" HELIX WITH MINIMUM 50" EMBEDMENT.
2. FOR CORAL USE MINIMUM (2) 4" HELICES WITH MINIMUM 30" EMBEDMENT OR SINGLE 6" HELIX WITH MINIMUM 50" EMBEDMENT.
3. FOR MEDIUM DENSE COARSE SANDS, SANDY GRAVELS, VERY STIFF SILTS, AND CLAYS USE MINIMUM (2) 4" HELICES WITH MINIMUM 30" INCH EMBEDMENT OR SINGLE 6" HELIX WITH MINIMUM 50" EMBEDMENT.
4. FOR LOOSE TO MEDIUM DENSE SANDS, FIRM TO STIFF CLAYS AND SILTS ALLUVIAL FILL, USE MINIMUM (2) 6" HELICES WITH MINIMUM 50" EMBEDMENT.
5. FOR VERY LOOSE TO MEDIUM DENSE SANDS, FIRM TO STIFFER CLAYS AND SILTS, ALLUVIAL FILL, USE MINIMUM (2) 8" HELICES WITH MINIMUM 60" EMBEDMENT.

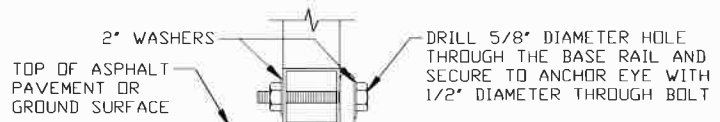

**2B GROUND BASE
HELIX ANCHORAGE**
SCALE: NTS
(CAN BE USED FOR ASPHALT)

**MOORE AND ASSOCIATES
ENGINEERING AND CONSULTING, INC.**

DRAWN BY: LT

CHECKED BY: PDH

PROJECT MGR: WSM

CLIENT: SBSI

STEEL BUILDINGS AND STRUCTURES, INC.
P.O. BOX 1287,
MOUNT AIRY, NC 27030
30'-0" x 20'-0" ENCLOSED STRUCTURE

DATE: 2-14-20

SHT. 9

SCALE: NTS

DWG. NO: SK-3

**JOB NO: 18068S
18156S/18290S/20019S**

REV: 8

THIS DOCUMENT IS THE PROPERTY OF MOORE AND ASSOCIATES ENGINEERING AND CONSULTING. THE UNAUTHORIZED REPRODUCTION, COPYING, OR OTHERWISE USE OF THIS DOCUMENT IS STRICTLY PROHIBITED AND ANY INFRINGEMENT THEREUPON MAY BE SUBJECT TO LEGAL ACTION.

ADDITIONAL BASE RAIL ANCHORAGE OPTION

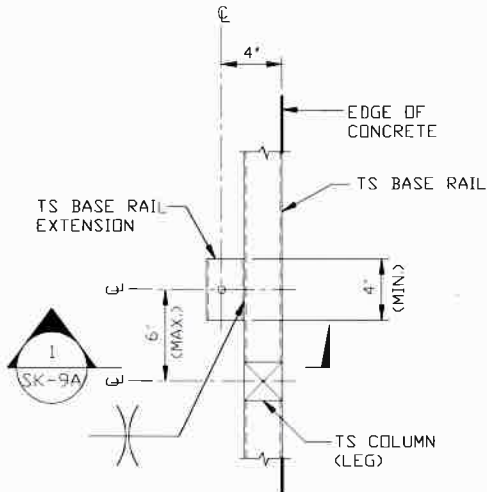

TYPICAL ANCHOR DETAIL WHEN BASE RAIL IS NEAR EDGE OF CONCRETE

SCALE: NTS

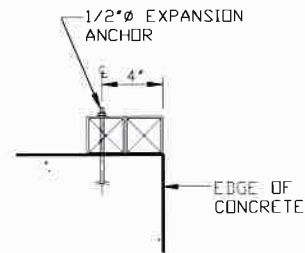

SECTION 1
SCALE: NTS

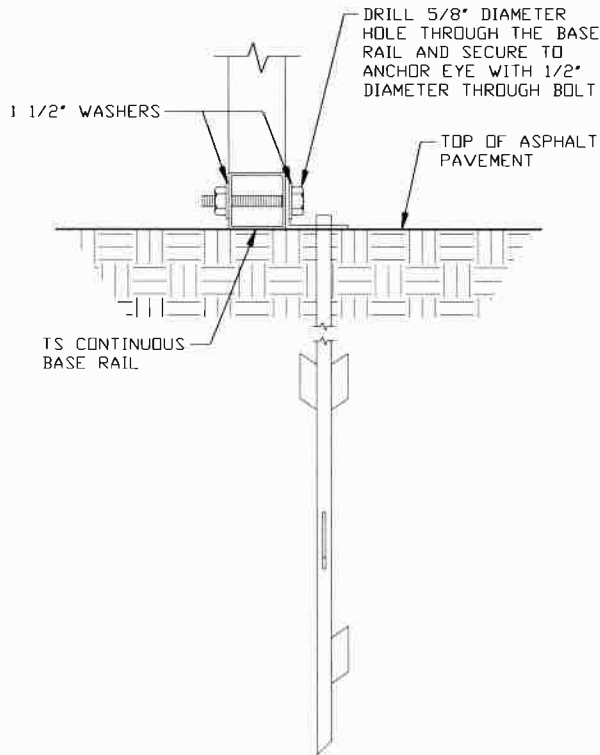

2C ASPHALT BASE ANCHORAGE
SCALE: NTS

**MOORE AND ASSOCIATES
ENGINEERING AND CONSULTING, INC.**

DRAWN BY: LT

CHECKED BY: PDH

PROJECT MGR: WSM

CLIENT: SBSI

STEEL BUILDINGS AND STRUCTURES, INC.
P.O. BOX 1287,
MOUNT AIRY, NC 27030
30'-0" x 20'-0" ENCLOSED STRUCTURE

DATE: 2-14-20

SHT. 9A

SCALE: NTS

DWG. NO: SK-3

**JOB NO: 18068S
18156S/18290S/20019S**

REV: 8

THIS DOCUMENT IS THE PROPERTY OF MOORE AND ASSOCIATES ENGINEERING AND CONSULTING. THE UNAUTHORIZED REPRODUCTION, COPYING, OR OTHERWISE USE OF THIS DOCUMENT IS STRICTLY PROHIBITED AND ANY INFRINGEMENT THEREUPON MAY BE SUBJECT TO LEGAL ACTION.

BOX EAVE RAFTER END WALL AND SIDE WALL OPENINGS

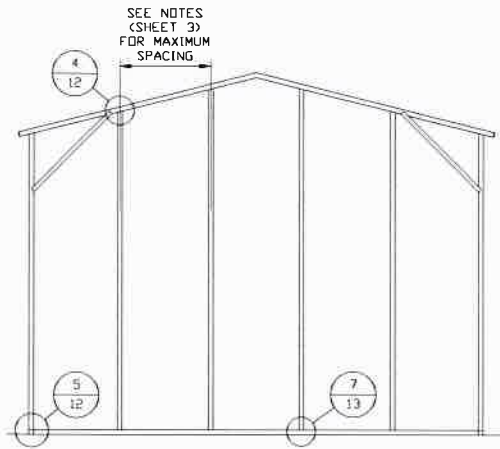

**TYPICAL BOX EAVE RAFTER
END WALL FRAMING SECTION**

SCALE: NTS

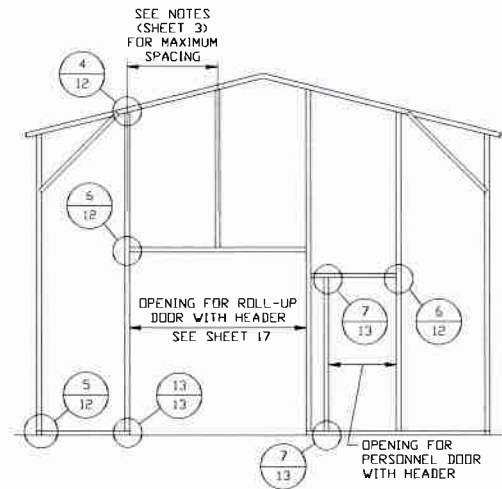

**TYPICAL BOX EAVE RAFTER END
WALL OPENINGS FRAMING SECTION**

SCALE: NTS

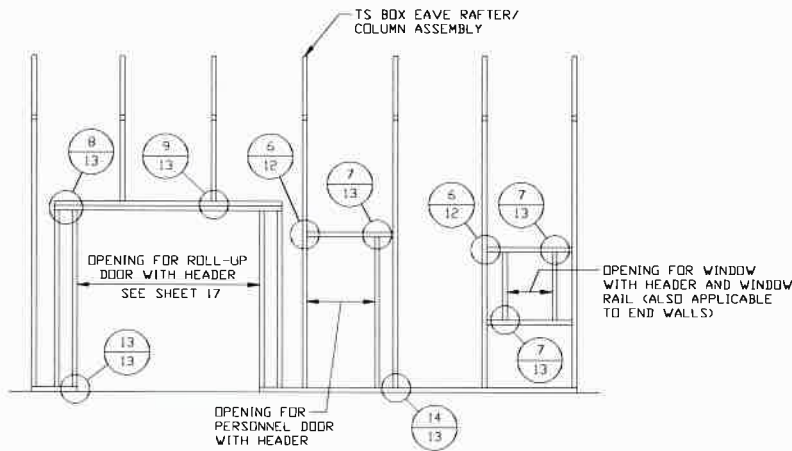

**TYPICAL BOX EAVE RAFTER
SIDE WALL OPENINGS FRAMING SECTION**

SCALE: NTS

**MOORE AND ASSOCIATES
ENGINEERING AND CONSULTING, INC.**

DRAWN BY: LT

CHECKED BY: PDH

PROJECT MGR: VSM

CLIENT: SBSI

STEEL BUILDINGS AND STRUCTURES, INC.
P.O. BOX 1287,
MOUNT AIRY, NC 27030
30'-0" x 20'-0" ENCLOSED STRUCTURE

DATE: 2-14-20

SHT. 10

SCALE: NTS

DWG. NO: SK-3

**JOB NO: 18068S
16156S/18290S/20019S**

REV: 8

THIS DOCUMENT IS THE PROPERTY OF MOORE AND ASSOCIATES ENGINEERING AND CONSULTING. THE UNAUTHORIZED REPRODUCTION, COPYING, OR OTHERWISE USE OF THIS DOCUMENT IS STRICTLY PROHIBITED AND ANY INFRINGEMENT THEREUPON MAY BE SUBJECT TO LEGAL ACTION.

BOW EAVE RAFTER END WALL AND SIDE WALL OPENINGS

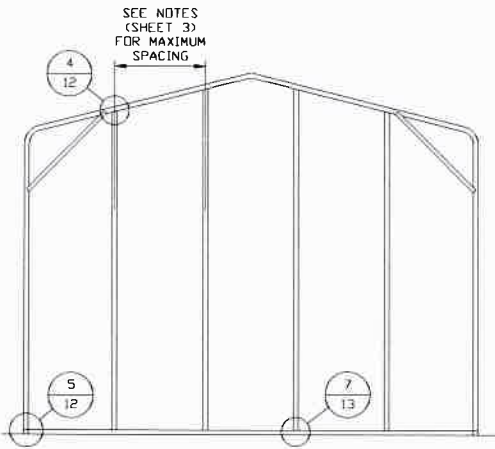

**TYPICAL BOX EAVE RAFTER
END WALL FRAMING SECTION**

SCALE: NTS

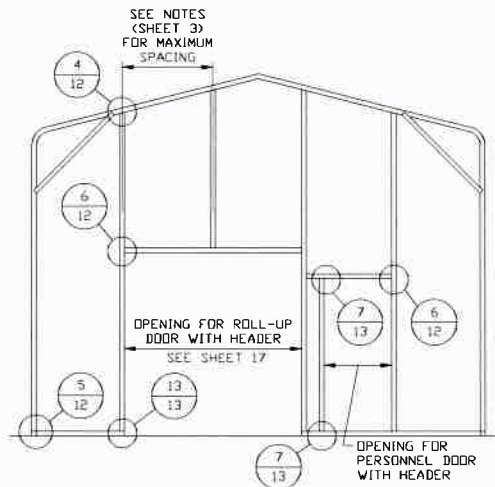

**TYPICAL BOX EAVE RAFTER END
WALL OPENINGS FRAMING SECTION**

SCALE: NTS

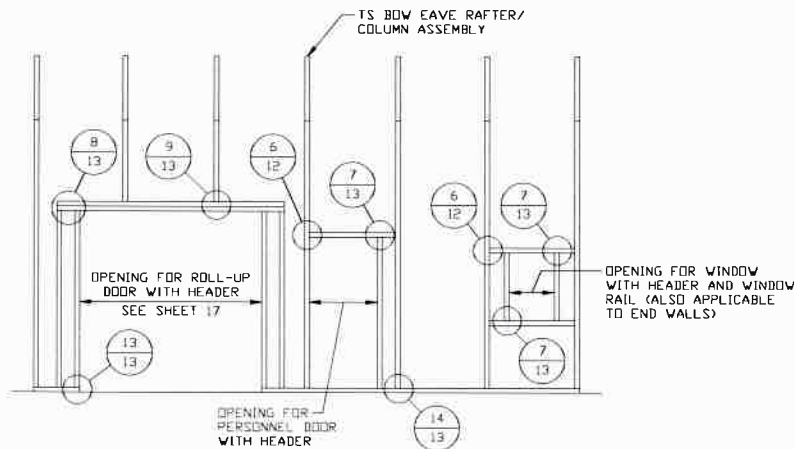

**TYPICAL BOX EAVE RAFTER
SIDE WALL OPENINGS FRAMING SECTION**

SCALE: NTS

**MOORE AND ASSOCIATES
ENGINEERING AND CONSULTING, INC.**

DRAWN BY: LT

CHECKED BY: PDH

PROJECT MGR: WSM

CLIENT: SBSI

STEEL BUILDINGS AND STRUCTURES, INC.
P.O. BOX 1287,
MOUNT AIRY, NC 27030
30'-0" x 20'-0" ENCLOSED STRUCTURE

DATE: 2-14-20

SHT. 11

SCALE: NTS

DWG. NO: SK-3

**JOB NO: 18068S
18156S/18290S/20019S**

REV: 8

THIS DOCUMENT IS THE PROPERTY OF MOORE AND ASSOCIATES ENGINEERING AND CONSULTING. THE UNAUTHORIZED REPRODUCTION, COPYING, OR OTHERWISE USE OF THIS DOCUMENT IS STRICTLY PROHIBITED AND ANY INFRINGEMENT THEREUPON MAY BE SUBJECT TO LEGAL ACTION.

CONNECTION DETAILS

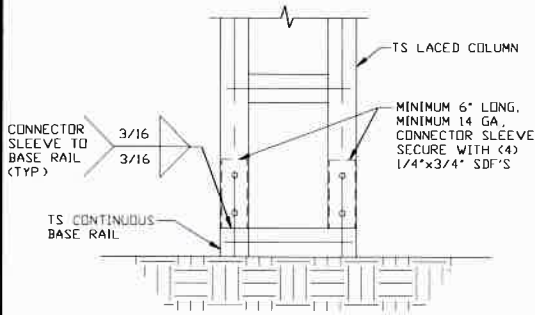

3
POST/BASE RAIL CONNECTION DETAIL
 SCALE: NTS

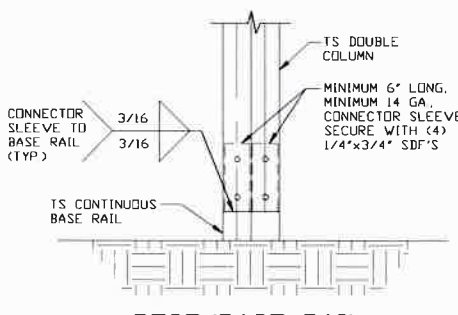

3A
POST/BASE RAIL CONNECTION DETAIL
 SCALE: NTS

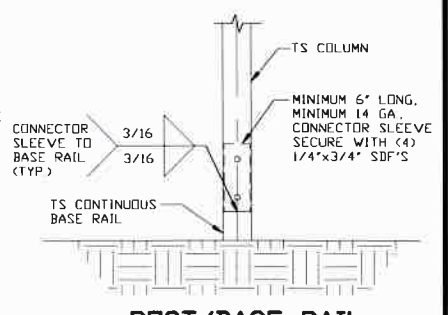

3B
POST/BASE RAIL CONNECTION DETAIL
 SCALE: NTS

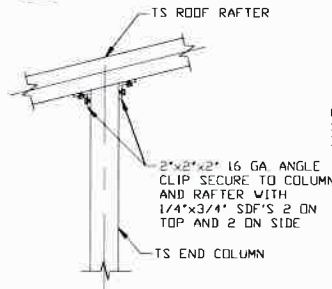

4
END COLUMN/RAFTER CONNECTION DETAIL
 SCALE: NTS

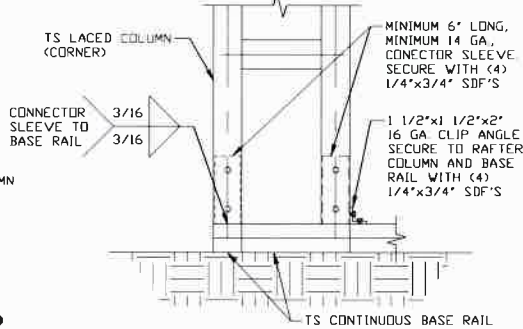

5
END COLUMN/BASE RAIL CONNECTION DETAIL
 SCALE: NTS

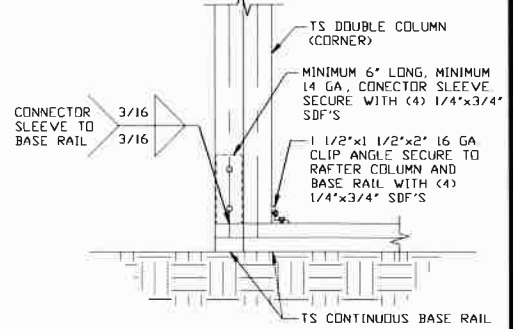

5A
END COLUMN/BASE RAIL CONNECTION DETAIL
 SCALE: NTS

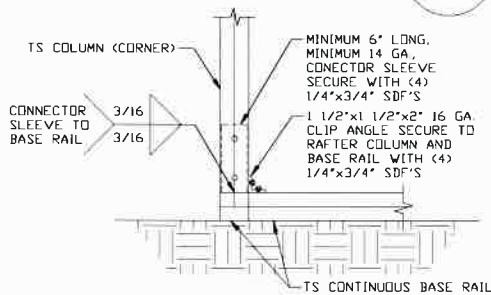

5B
END COLUMN/BASE RAIL CONNECTION DETAIL
 SCALE: NTS

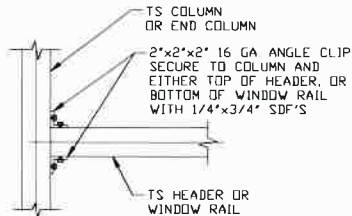

6
COLUMN OR WINDOW RAIL/WALL GIRT TO POST CONNECTION DETAIL
 SCALE: NTS

**MOORE AND ASSOCIATES
 ENGINEERING AND CONSULTING, INC.**

DRAWN BY: LT

CHECKED BY: PDH

PROJECT MGR: WSM

CLIENT: SBSI

STEEL BUILDINGS AND STRUCTURES, INC.
 P.O. BOX 1287,
 MOUNT AIRY, NC 27030
 30'-0"x20'-0" ENCLOSED STRUCTURE

DATE: 2-14-20

SHT. 12

SCALE: NTS

DWG. NO: SK-3

**JOB NO: 18068S
 18156S/18290S/20019S**

REV: 8

THIS DOCUMENT IS THE PROPERTY OF MOORE AND ASSOCIATES ENGINEERING AND CONSULTING. THE UNAUTHORIZED REPRODUCTION, COPYING, OR OTHERWISE USE OF THIS DOCUMENT IS STRICTLY PROHIBITED AND ANY INFRINGEMENT THEREUPON MAY BE SUBJECT TO LEGAL ACTION.

CONNECTION DETAILS

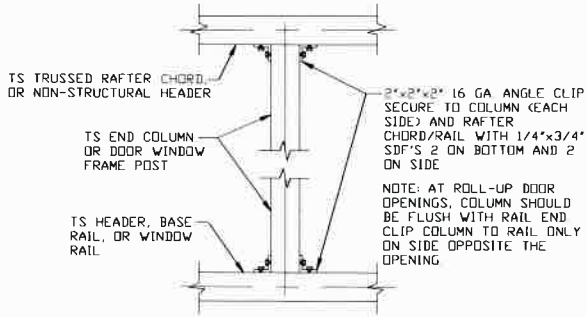

7 COLUMN TO HEADER, BASE RAIL, OR WINDOW RAIL CONNECTION DETAIL

SCALE: NTS

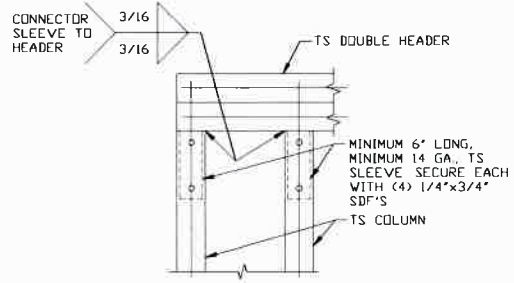

8 DOUBLE HEADER/COLUMN CONNECTION DETAIL

SCALE: NTS

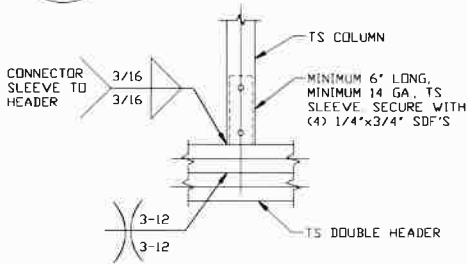

9 COLUMN/DOUBLE HEADER CONNECTION DETAIL

SCALE: NTS

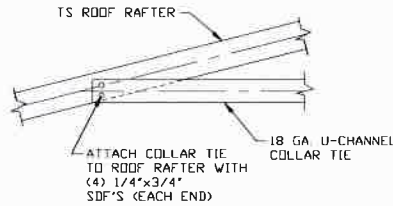

10 COLLAR TIE CONNECTION DETAIL

SCALE: NTS

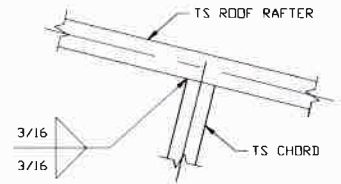

11 RAFTER TO CHORD CONNECTION DETAIL

SCALE: NTS

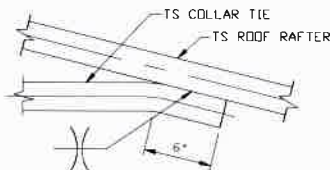

12 COLLAR TIE CONNECTION DETAIL

SCALE: NTS

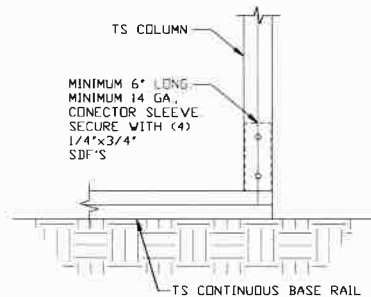

13 COLUMN/BASE RAIL CONNECTION DETAIL

SCALE: NTS

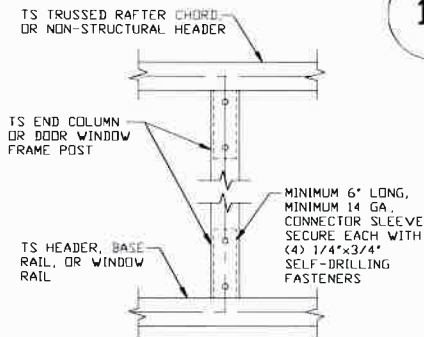

14 COLUMN TO HEADER OR BASE RAIL CONNECTION DETAIL

SCALE: NTS

**MOORE AND ASSOCIATES
ENGINEERING AND CONSULTING, INC.**

DRAWN BY: LT

CHECKED BY: PDH

PROJECT MGR: WSM

CLIENT: SBSI

STEEL BUILDINGS AND STRUCTURES, INC.
P.O. BOX 1287,
MOUNT AIRY, NC 27030
30'-0" x 20'-0" ENCLOSED STRUCTURE

DATE: 2-14-20

SHT. 13

SCALE: NTS

DWG. NO: SK-3

JOB NO: 18068S
18156S/18290S/20019S

REV: 8

THIS DOCUMENT IS THE PROPERTY OF MOORE AND ASSOCIATES ENGINEERING AND CONSULTING. THE UNAUTHORIZED REPRODUCTION, COPYING, OR OTHERWISE USE OF THIS DOCUMENT IS STRICTLY PROHIBITED AND ANY INFRINGEMENT THEREUPON MAY BE SUBJECT TO LEGAL ACTION.

BOX EAVE RAFTER LEAN-TO OPTIONS

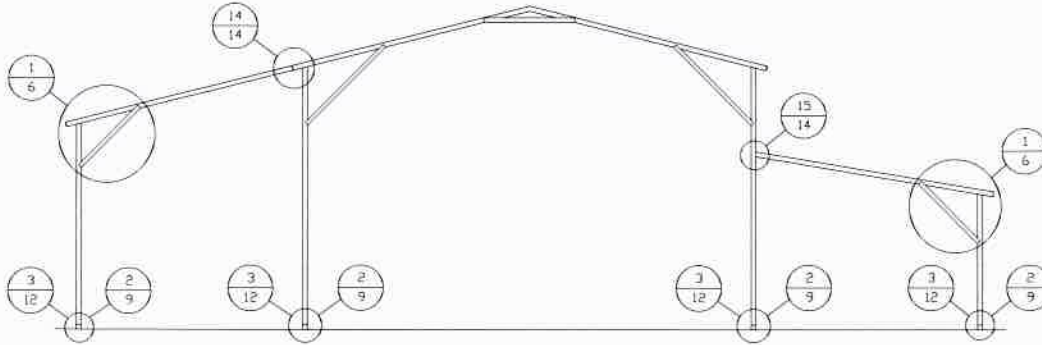

TYPICAL BOX EAVE RAFTER LEAN-TO OPTIONS FRAMING SECTION (BOTH OPTIONS SHOWN)

SCALE: NTS

MAXIMUM WIDTH OF SINGLE MEMBER (RAFTER) ROOF EXTENSION LEAN-TO IS 12'-0"

MAXIMUM WIDTH OF DOUBLE MEMBER RAFTER ROOF EXTENSION LEAN-TO IS 16'-0"

FOR SHARED COLUMN HEIGHTS REFERENCE RAFTER COLUMN CONNECTION DETAILS FOR APPROPRIATE COLUMN HEIGHT AND TUBING SPECIFICATIONS.

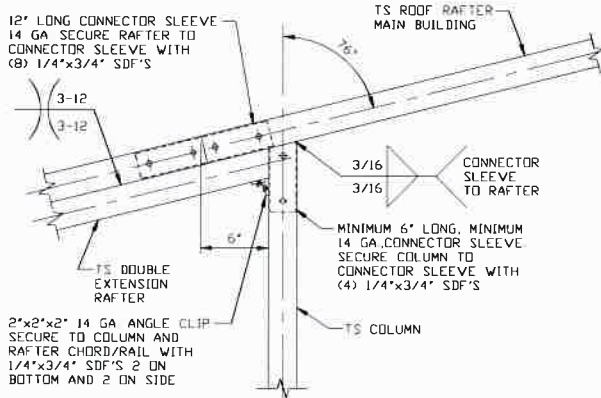

14 **SIDE EXTENSION RAFTER/
COLUMN DETAIL FOR RAFTER
SPANS 12'-0" < TO < 16'-0"**

SCALE: NTS

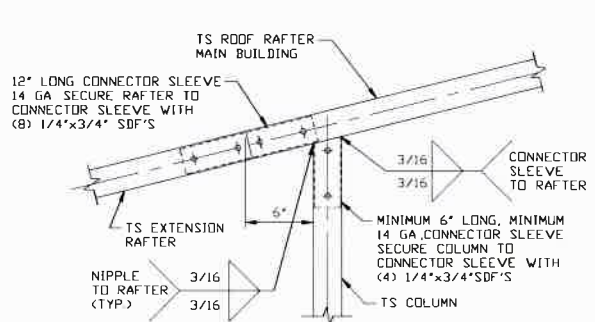

14A **SIDE EXTENSION RAFTER/
COLUMN DETAIL FOR
RAFTER SPANS ≤ 12'-0"**

SCALE: NTS

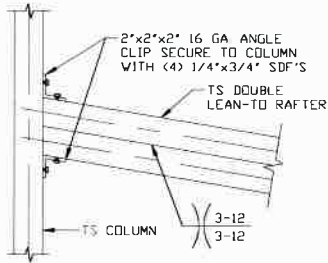

15 **LEAN-TO RAFTER
TO RAFTER POST
CONNECTION DETAIL
FOR WIDTHS
12'-0" < TO < 16'-0"**

SCALE: NTS

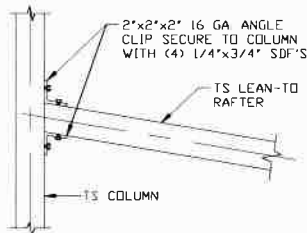

15A **LEAN-TO RAFTER
TO RAFTER POST
CONNECTION DETAIL
FOR WIDTHS ≤ 12'-0"**

SCALE: NTS

**MOORE AND ASSOCIATES
ENGINEERING AND CONSULTING, INC.**

DRAWN BY: LT

CHECKED BY: PDH

PROJECT MGR: WSM

CLIENT: SBSI

STEEL BUILDINGS AND STRUCTURES, INC.
P.O. BOX 1287,
MOUNT AIRY, NC 27030
30'-0" x 20'-0" ENCLOSED STRUCTURE

DATE: 2-14-20

SHT. 14

SCALE: NTS

DWG. NO: SK-3

**JOB NO: 18068S
18156S/18290S/20019S**

REV: 8

THIS DOCUMENT IS THE PROPERTY OF MOORE AND ASSOCIATES ENGINEERING AND CONSULTING. THE UNAUTHORIZED REPRODUCTION, COPYING, OR OTHERWISE USE OF THIS DOCUMENT IS STRICTLY PROHIBITED AND ANY INFRINGEMENT THEREUPON MAY BE SUBJECT TO LEGAL ACTION.

BOW EAVE RAFTER LEAN-TO OPTIONS

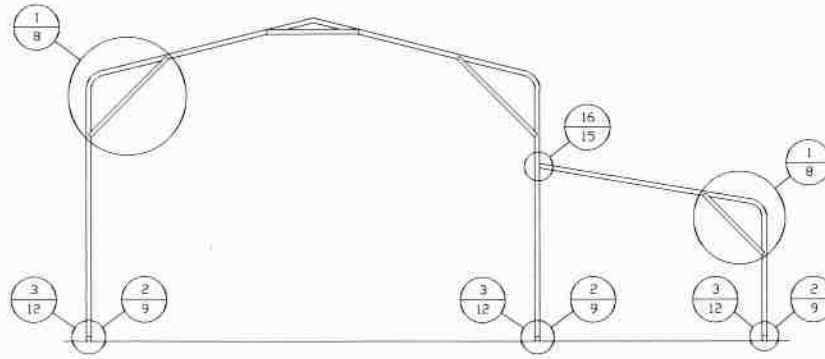

TYPICAL BOW EAVE RAFTER LEAN-TO OPTIONS FRAMING SECTION

SCALE: NTS

MAXIMUM WIDTH OF SINGLE MEMBER (RAFTER) ROOF EXTENSION LEAN-TO IS 12'-0"

MAXIMUM WIDTH OF DOUBLE MEMBER RAFTER ROOF EXTENSION LEAN-TO IS 16'-0"

FOR SHARED COLUMN HEIGHTS REFERENCE RAFTER COLUMN CONNECTION DETAILS FOR APPROPRIATE COLUMN HEIGHT AND TUBING SPECIFICATIONS.

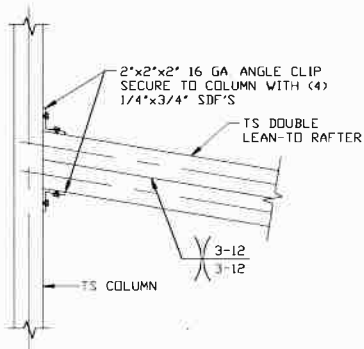

**LEAN-TO RAFTER TO
RAFTER POST
CONNECTION
DETAIL FOR WIDTHS
12'-0" < TO ≤ 16'-0"**

16

SCALE: NTS

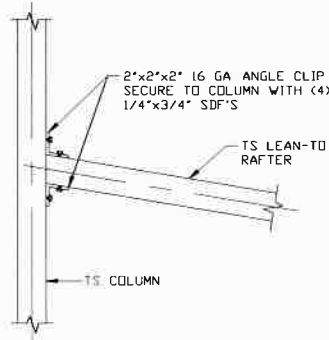

**LEAN-TO RAFTER
TO RAFTER POST
CONNECTION
DETAIL
FOR WIDTHS ≤ 12'-0"**

16A

SCALE: NTS

**MOORE AND ASSOCIATES
ENGINEERING AND CONSULTING, INC.**

DRAWN BY: LT

CHECKED BY: PDH

PROJECT MGR: WSH

CLIENT: SBSI

STEEL BUILDINGS AND STRUCTURES, INC.
P.O. BOX 1287,
MOUNT AIRY, NC 27030
30'-0" x 20'-0" ENCLOSED STRUCTURE

DATE: 2-14-20

SHT. 15

SCALE: NTS

DWG. NO: SK-3

**JOB NO: 18068S
18156S/18290S/20019S**

REV: 8

THIS DOCUMENT IS THE PROPERTY OF MOORE AND ASSOCIATES ENGINEERING AND CONSULTING. THE UNAUTHORIZED REPRODUCTION, COPYING, OR OTHERWISE USE OF THIS DOCUMENT IS STRICTLY PROHIBITED AND ANY INFRINGEMENT THEREUPON MAY BE SUBJECT TO LEGAL ACTION.

BOX EAVE RAFTER VERTICAL ROOF/SIDING OPTION

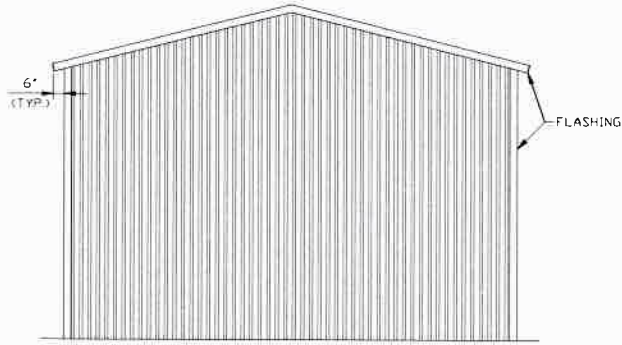

**TYPICAL END ELEVATION
VERTICAL ROOF/SIDING**

SCALE: NTS

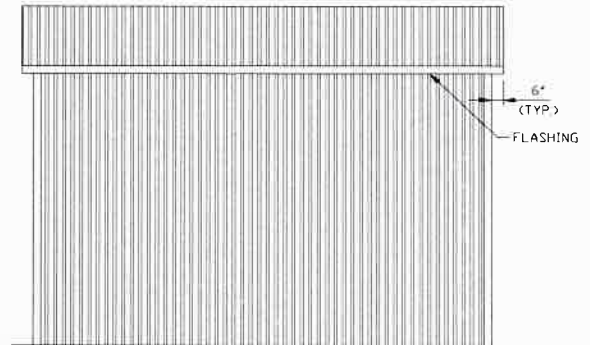

**TYPICAL SIDE ELEVATION
VERTICAL ROOF/SIDING**

SCALE: NTS

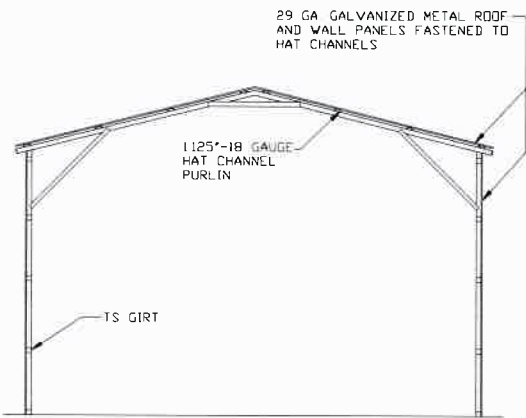

**TYPICAL SECTION
VERTICAL ROOF/SIDING OPTION**

SCALE: NTS

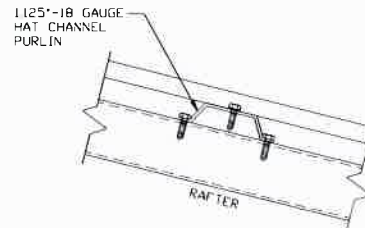

PANEL ATTACHMENT

(ALTERNATE FOR VERTICAL ROOF PANELS)
SCALE: NTS

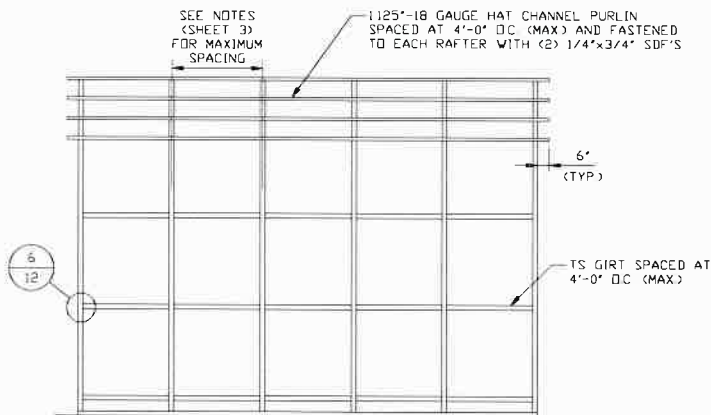

**TYPICAL FRAMING SECTION
VERTICAL ROOF/SIDING OPTION**

SCALE: NTS

**MOORE AND ASSOCIATES
ENGINEERING AND CONSULTING, INC.**

DRAWN BY: LT

CHECKED BY: PDH

PROJECT MGR: WSM

CLIENT: SBSI

STEEL BUILDINGS AND STRUCTURES, INC.
P.O. BOX 1287,
MOUNT AIRY, NC 27030
30'-0" x 20'-0" ENCLOSED STRUCTURE

DATE: 2-14-20

SHT. 16

SCALE: NTS

DWG. NO: SK-3

**JOB NO: 18068S
18156S/18290S/20019S**

REV: 8

THIS DOCUMENT IS THE PROPERTY OF MOORE AND ASSOCIATES ENGINEERING AND CONSULTING. THE UNAUTHORIZED REPRODUCTION, COPYING, OR OTHERWISE USE OF THIS DOCUMENT IS STRICTLY PROHIBITED AND ANY INFRINGEMENT THEREUPON MAY BE SUBJECT TO LEGAL ACTION.

SIDE WALL HEADER OPTIONS

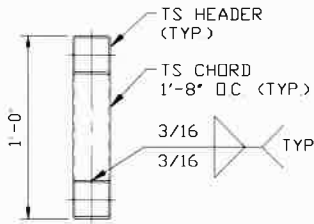

LACED HEADER DETAIL FOR DOOR OPENINGS 12'-0" < LENGTH < 20'-0"
SCALE: NTS

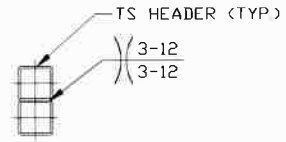

DOUBLE HEADER DETAIL FOR DOOR OPENINGS 7'-0" < LENGTH < 12'-0"
SCALE: NTS

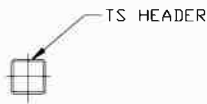

SINGLE HEADER DETAIL FOR DOOR OPENINGS LENGTH < 7'-0"
SCALE: NTS

END WALL HEADER OPTIONS

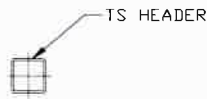

SINGLE HEADER DETAIL FOR DOOR OPENINGS LENGTH < 12'-0"
SCALE: NTS

**MOORE AND ASSOCIATES
ENGINEERING AND CONSULTING, INC.**

DRAWN BY: LT

CHECKED BY: PDH

PROJECT MGR: WSM

CLIENT: SBSI

STEEL BUILDINGS AND STRUCTURES, INC.
P.O. BOX 1287,
MOUNT AIRY, NC 27030
30'-0"x20'-0" ENCLOSED STRUCTURE

DATE: 2-14-20

SHT. 17

SCALE: NTS

DWG. NO: SK-3

**JOB NO: 18068S
18156S/18290S/20019S**

REV: 8

THIS DOCUMENT IS THE PROPERTY OF MOORE AND ASSOCIATES ENGINEERING AND CONSULTING. THE UNAUTHORIZED REPRODUCTION, COPYING, OR OTHERWISE USE OF THIS DOCUMENT IS STRICTLY PROHIBITED AND ANY INFRINGEMENT THEREUPON MAY BE SUBJECT TO LEGAL ACTION.

OPTIONAL BASE RAIL ON GRADE APPLICATION

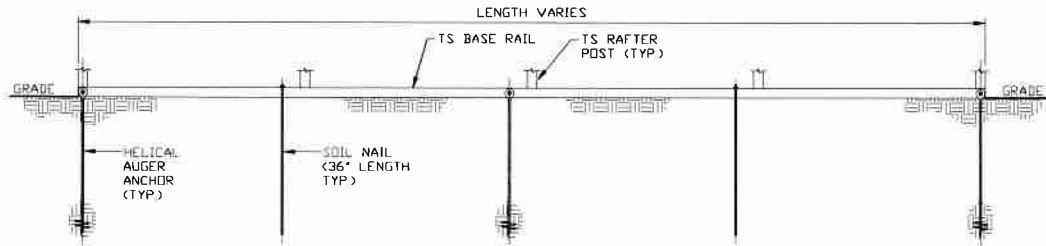

SECTION 2
SCALE: NTS

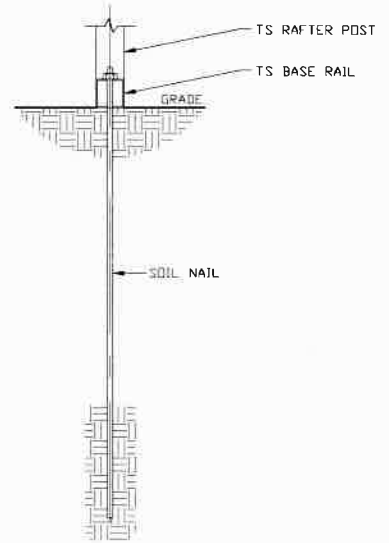

SECTION 1
SCALE: NTS

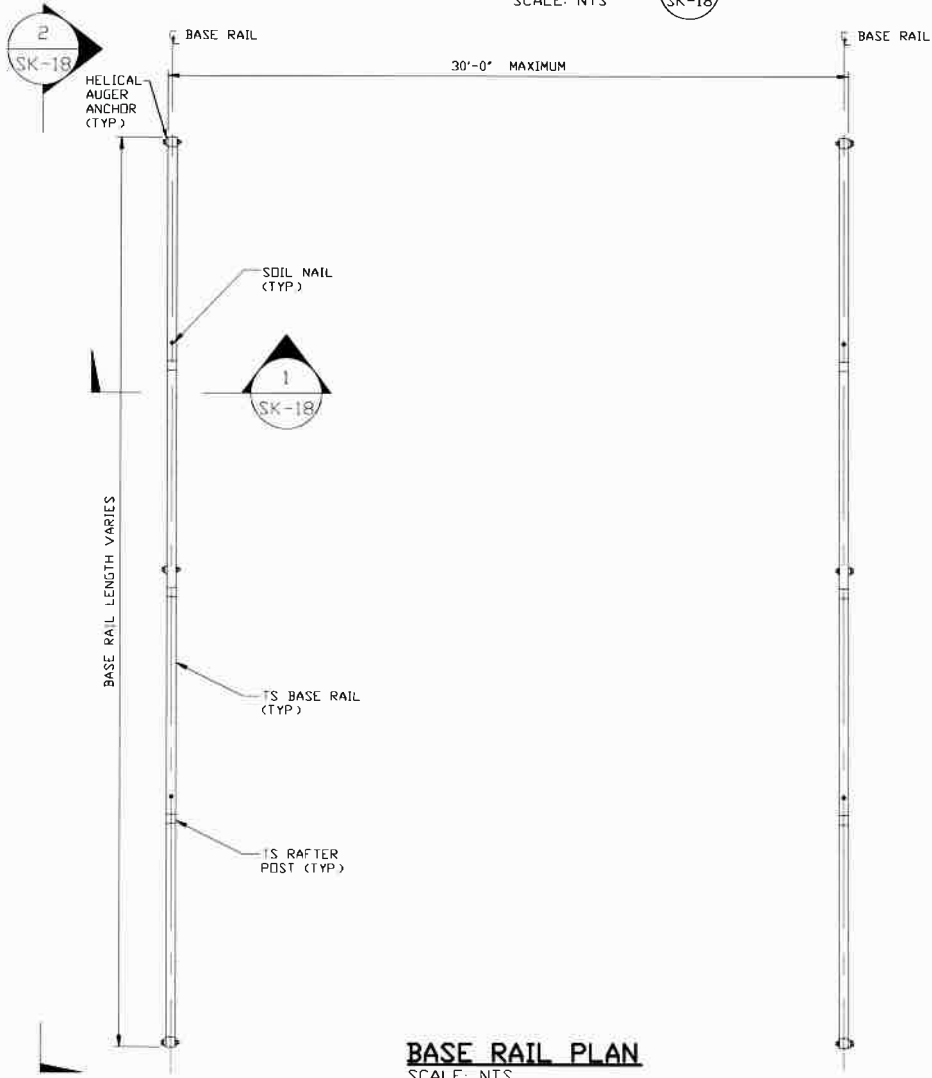

BASE RAIL PLAN
SCALE: NTS

HELIX ANCHOR	
SIDE LENGTH	MAXIMUM SPACING
VARIES	10'-0" (EVERY OTHER POST)

**MOORE AND ASSOCIATES
ENGINEERING AND CONSULTING, INC.**

DRAWN BY: LT

CHECKED BY: PDH

PROJECT MGR: WSH

CLIENT: SBSI

STEEL BUILDINGS AND STRUCTURES, INC.
P.O. BOX 1287,
MOUNT AIRY, NC 27030
30'-0" x 20'-0" ENCLOSED STRUCTURE

DATE: 2-14-20

SHT. 18

SCALE: NTS

DWG. NO: SK-3

**JOB NO: 18068S
18156S/18290S/20019S**

REV: 8

THIS DOCUMENT IS THE PROPERTY OF MOORE AND ASSOCIATES ENGINEERING AND CONSULTING. THE UNAUTHORIZED REPRODUCTION, COPYING, OR OTHERWISE USE OF THIS DOCUMENT IS STRICTLY PROHIBITED AND ANY INFRINGEMENT THEREUPON MAY BE SUBJECT TO LEGAL ACTION.

OPTIONAL BASE RAIL ON TIMBER BEAM

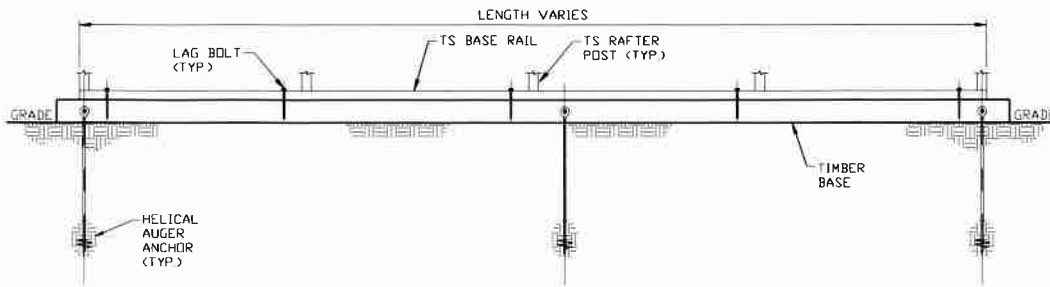

SECTION 2
SCALE: NTS

2
SK-19

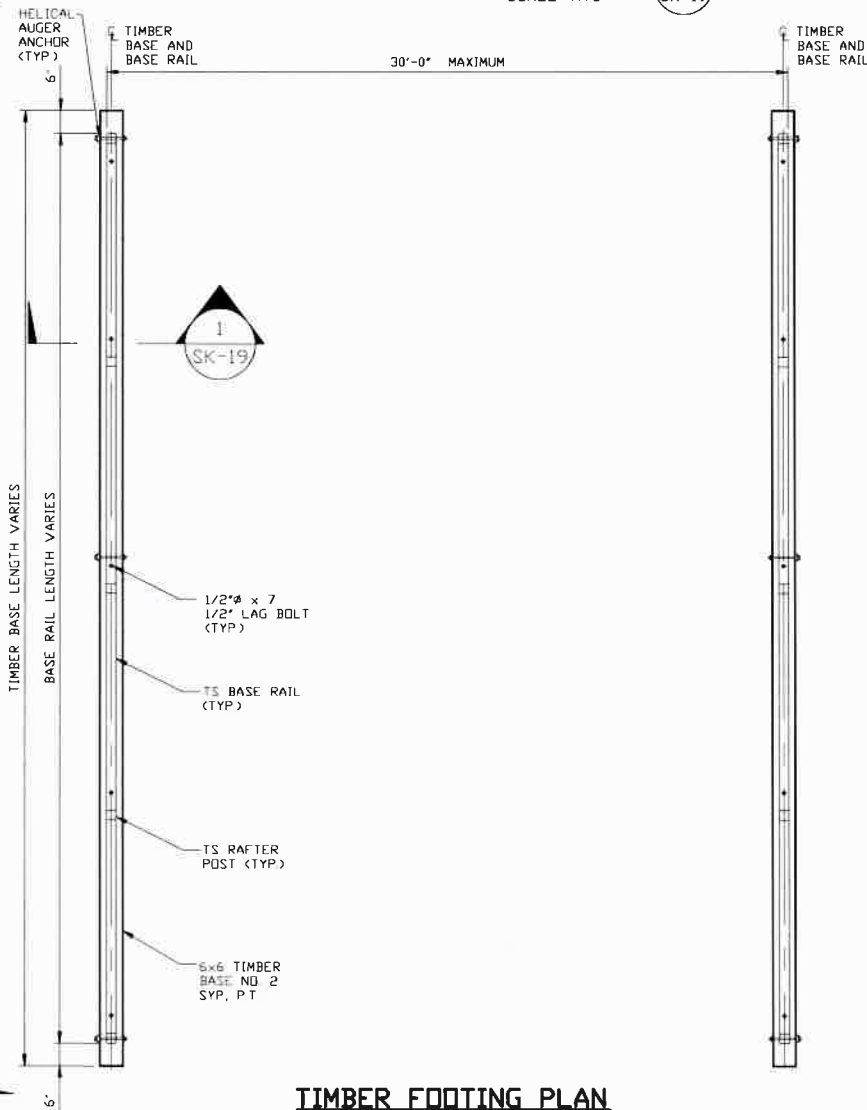

TIMBER FOOTING PLAN
SCALE: NTS

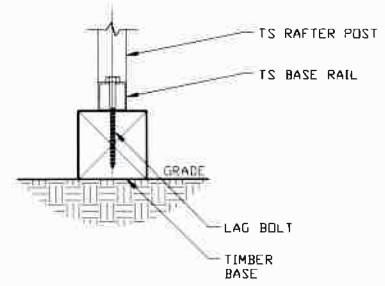

SECTION 1
SCALE: NTS

HELIX ANCHOR	
SIDE LENGTH	MAXIMUM SPACING
VARIES	10'-0" (EVERY OTHER POST)

**MOORE AND ASSOCIATES
ENGINEERING AND CONSULTING, INC.**

DRAWN BY: LT
CHECKED BY: PDH

STEEL BUILDINGS AND STRUCTURES, INC.
P.O. BOX 1287,
MOUNT AIRY, NC 27030
30'-0" x 20'-0" ENCLOSED STRUCTURE

THIS DOCUMENT IS THE PROPERTY OF MOORE AND ASSOCIATES ENGINEERING AND CONSULTING. THE UNAUTHORIZED REPRODUCTION, COPYING, OR OTHERWISE USE OF THIS DOCUMENT IS STRICTLY PROHIBITED AND ANY INFRINGEMENT THEREUPON MAY BE SUBJECT TO LEGAL ACTION.

PROJECT MGR: WSM	DATE: 2-14-20	SCALE: NTS	JOB NO: 18068S 18156S/18290S/20019S
CLIENT: SBSI	SHT. 19	DWG. NO: SK-3	REV: 8

OPTIONAL BASE RAIL ON TIMBER BEAM WITH SOIL NAIL

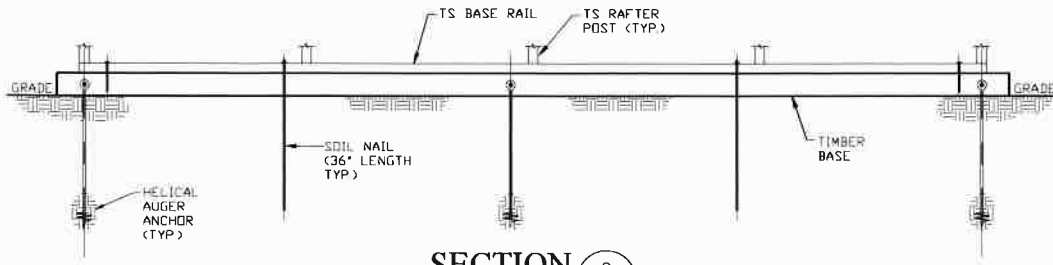

SECTION 2
SCALE: NTS

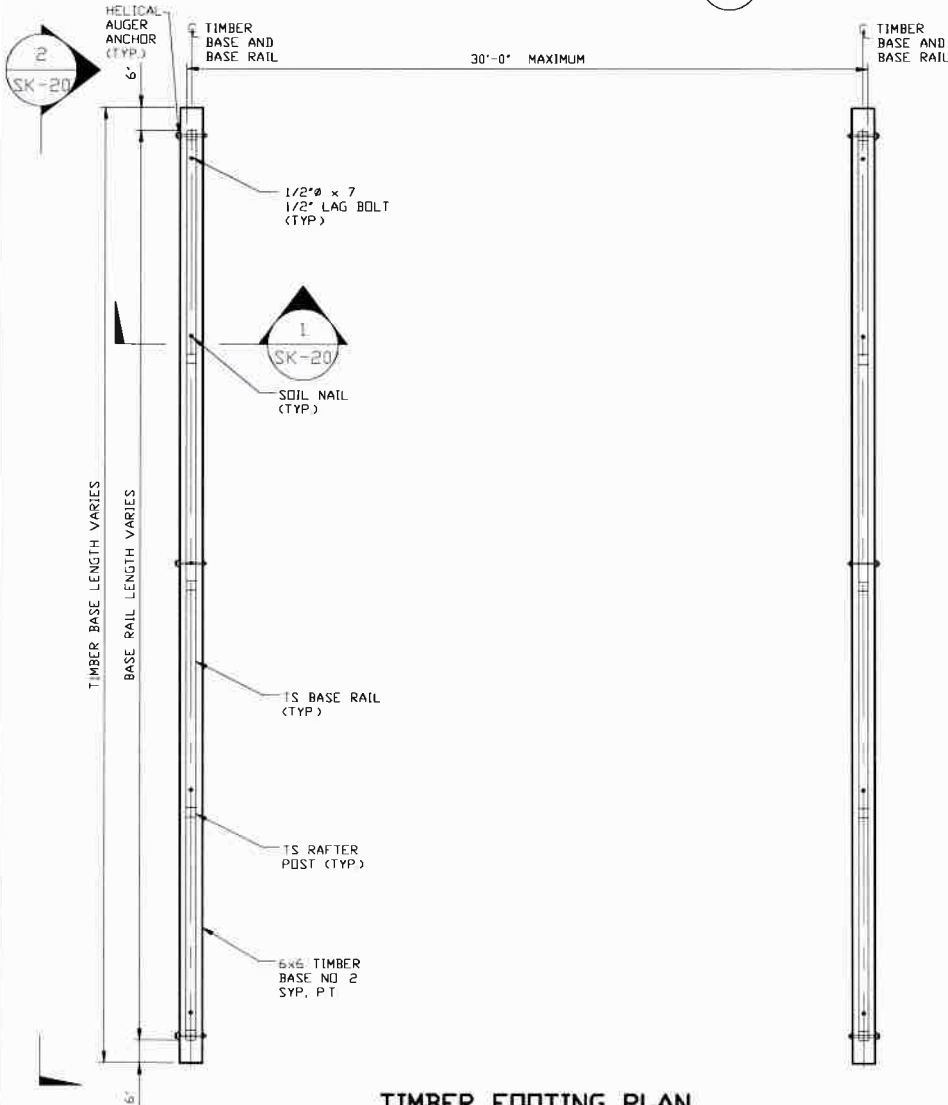

TIMBER FOOTING PLAN
SCALE: NTS

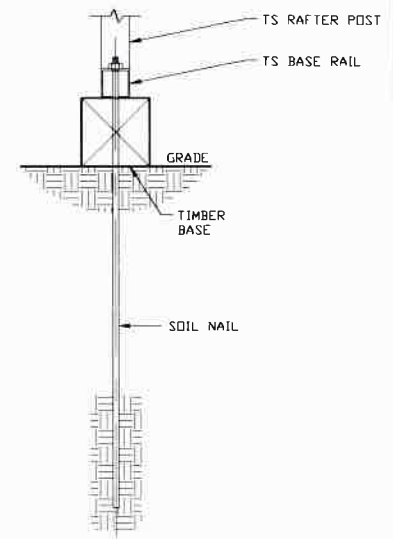

SECTION 1
SCALE: NTS

HELIX ANCHOR	
SIDE LENGTH	MAXIMUM SPACING
VARIES	10'-0" (EVERY OTHER POST)

**MOORE AND ASSOCIATES
ENGINEERING AND CONSULTING, INC.**

DRAWN BY: LT

CHECKED BY: PDH

PROJECT MGR: WSM

CLIENT: SBSI

STEEL BUILDINGS AND STRUCTURES, INC.
P.O. BOX 1287,
MOUNT AIRY, NC 27030
30'-0" x 20'-0" ENCLOSED STRUCTURE

DATE: 2-14-20

SHT. 20

SCALE: NTS

DWG. NO: SK-3

**JOB NO: 18068S
18156S/18290S/20019S**

REV: 8

THIS DOCUMENT IS THE PROPERTY OF MOORE AND ASSOCIATES ENGINEERING AND CONSULTING. THE UNAUTHORIZED REPRODUCTION, COPYING, OR OTHERWISE USE OF THIS DOCUMENT IS STRICTLY PROHIBITED AND ANY INFRINGEMENT THEREUPON MAY BE SUBJECT TO LEGAL ACTION.

OPTIONAL CONCRETE STRIP FOOTING

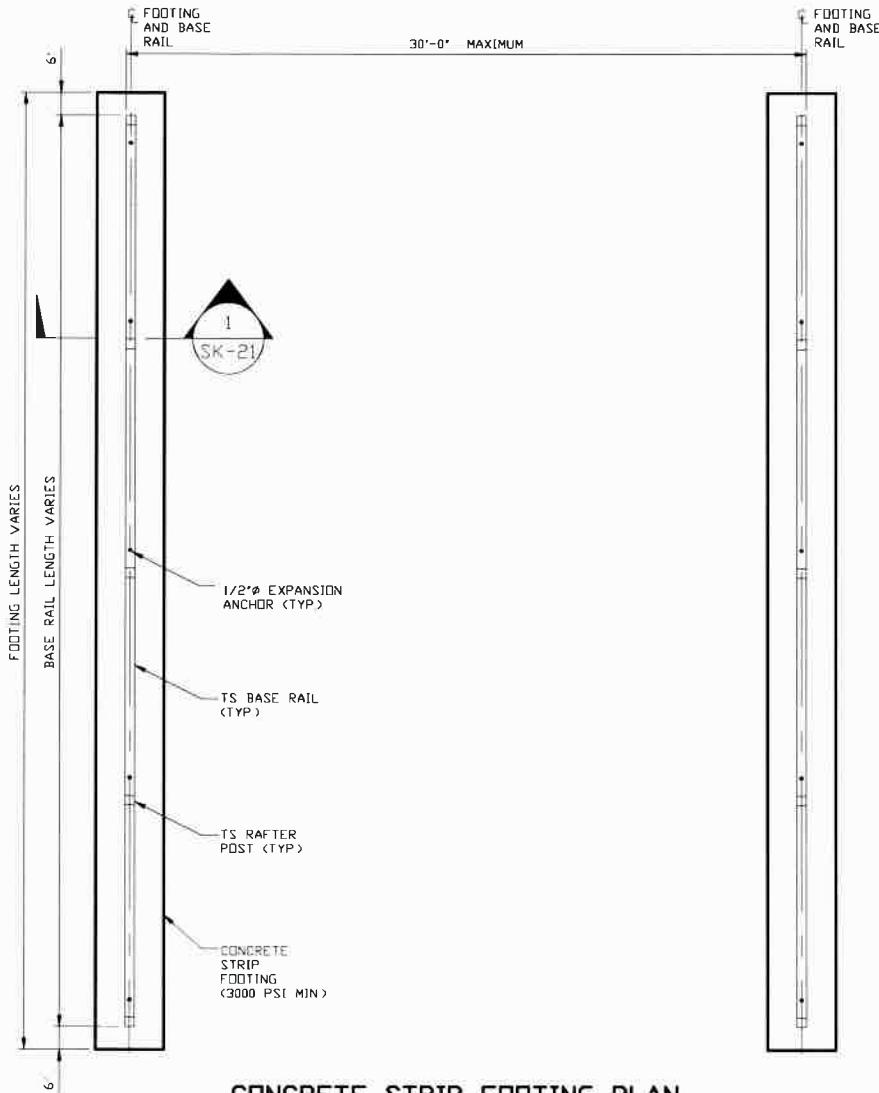

CONCRETE STRIP FOOTING PLAN
SCALE: NTS

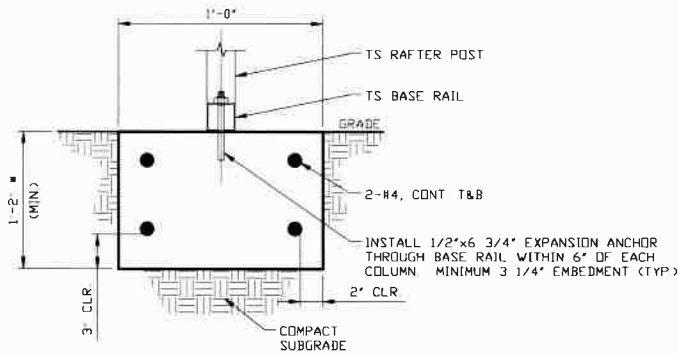

SECTION 1
SCALE: NTS
SK-21

* COORDINATE WITH LOCAL CODES/ORD

**MOORE AND ASSOCIATES
ENGINEERING AND CONSULTING, INC.**

DRAWN BY: LT

CHECKED BY: PDH

PROJECT MGR: WSM

CLIENT: SBSI

STEEL BUILDINGS AND STRUCTURES, INC.
P.O. BOX 1287,
MOUNT AIRY, NC 27030
30'-0" x 20'-0" ENCLOSED STRUCTURE

DATE: 2-14-20

SHT. 21

SCALE: NTS

DWG. NO: SK-3

**JOB NO: 18068S
18156S/18290S/20019S**

REV: 8

THIS DOCUMENT IS THE PROPERTY OF MOORE AND ASSOCIATES ENGINEERING AND CONSULTING. THE UNAUTHORIZED REPRODUCTION, COPYING, OR OTHERWISE USE OF THIS DOCUMENT IS STRICTLY PROHIBITED AND ANY INFRINGEMENT THEREUPON MAY BE SUBJECT TO LEGAL ACTION.