

For accessory use only

This step by step diy project is about **16x24 gambrel shed plans**. I have designed this 16x24 barn storage shed with studs every 24" OC, so you can finally have that workshop you have always dreamed about. In addition, you have a super easy access to the shed, due to the double doors. Make adjustments to the plans so the shed suits your needs. Take a look over the rest of my [woodworking plans](#), if you want to get more building inspiration.

**Remember that you need to select the site for the shed with attention and that you have to comply with a few legal regulations. It is your duty to make the modifications to comply with local codes.*

When buying the lumber, you should select the planks with great care, making sure they are straight and without any visible flaws (cracks, knots, twists, decay). Investing in cedar or other weather resistant lumber is a good idea, as it will pay off on the long run. Use a spirit level to plumb and align the components, before inserting the galvanized screws, otherwise the project won't have a symmetrical look. If you have all the materials and tools required for the project, you could get the job done in about a day.

16x24 Gambrel Shed Plans

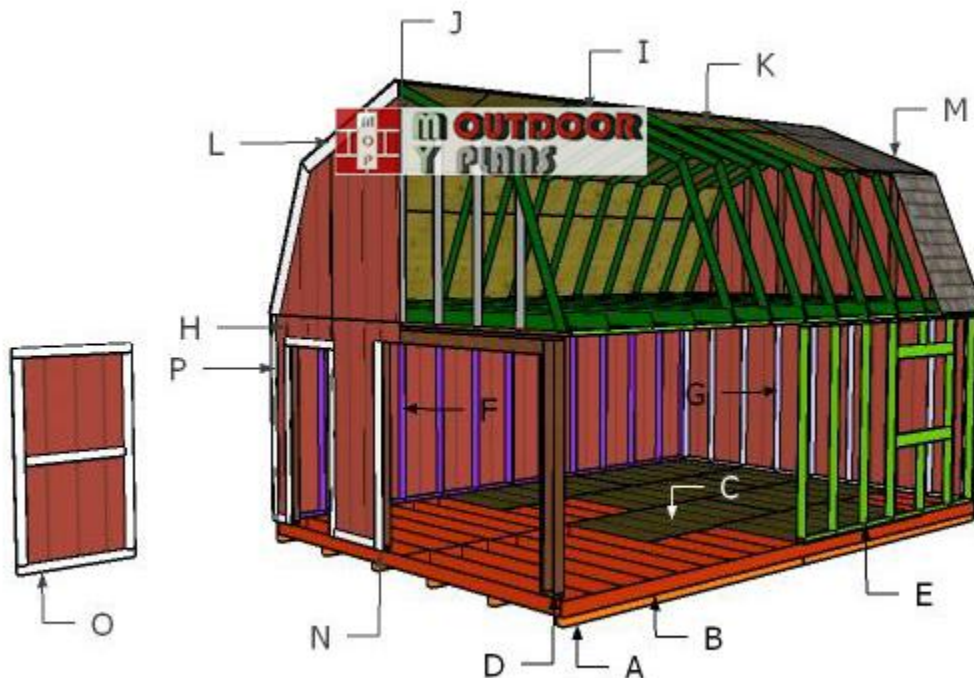

MyOutdoorPlans.com

Building-a-16x24-barn-shed

Cut + Shopping Lists

- **A** - 12 pieces of 4x4 lumber - 144" long **SKIDS**
- **B** - 2 pieces of 2x6 lumber - 288" long, 19 pieces - 189" long, 2 pieces - 13 3/4" long, 16 pieces - 14 1/2" long **FLOOR FRAME**
- **C** - 10 pieces of 3/4" plywood - 48"x96" long, 4 pieces - 48"x48" long **FLOOR**
- **D** - 1 piece of 2x4 lumber - 185" long, 1 piece - 192" long, 1 piece - 10 1/4" long, 1 piece - 38 1/4" long, 1 piece - 8 1/2" long, 7 pieces - 91 1/2" long, 2 pieces - 81" long, 2 pieces - 86" long, 3 pieces - 5" long, 2 pieces of 2x6 lumber - 99" long, 2 pieces - 35" long **FRONT WALL**
- **E** - 4 pieces of 2x4 lumber - 144" long, 1 piece - 281" long, 7 pieces - 91 1/2" long, 4 pieces - 36" long, 3 pieces - 12" long, 3 pieces - 32 1/2" long, 4 pieces of 2x6 lumber - 51" long **SIDE WALL**
- **F** - 4 piece of 2x4 lumber - 144" long, 1 piece - 281" long, 16 pieces - 91 1/2" long **SIDE WALL**
- **G** - 2 pieces of 2x4 lumber - 185" long, 1 piece - 192" long, 9 pieces - 91 1/2" long **BACK WALL**
- **H** - 20 pieces of T1-11 5/8" siding - 48"x96" long **SIDING**
- **H** - 4 pieces of T1-11 siding - 48"x76 1/4" long, 4 pieces - 48"x96" long **SIDING**
- **I** - 4 pieces of 2x4 lumber - 73 1/2" long, 1 piece of 2x6 lumber - 192" long **13xTRUSSES**
- **J** - 4 pieces of 2x4 lumber - 53" long, 4 pieces - 73" long, 4 pieces - 83" long, 2 pieces - 92 1/4" long **SUPPORTS**
- **K** - 12 pieces of 3/4" plywood - 48"x96" long, 8 pieces - 25 1/2"x96" long, 8 pieces - 25 1/2"x48" long **ROOF**
- **M** - 8 pieces of 2x6 lumber - 74" long **OVERHANGS**
- **N** - 2 pieces of 2x4 lumber - 87 1/2" long, 1 piece - 103" long **JAMB**
- **O** - 2 pieces of 2x4 lumber - 80 1/2" long, 2 pieces - 48" long, 1 piece - 41" long, 1 piece of T1-11 siding - 48"x87 1/2" long **2xDOOR**
- **P** - 4 pieces of 1x4 lumber - 36" long, 4 pieces - 55" long, 2 pieces - 82 1/2" long, 1 piece - 39" long **DOOR AND WINDOW TRIMS**
- **P** - 8 pieces of 1x4 lumber - 96" long, 2 pieces - 282 1/4" long, 1 piece - 187 3/4" long, 1 piece - 8" long, 1 piece - 31 1/4" long, 1 piece - 6 1" long **TRIMS**

-
- 12 pieces of 4x4 lumber - 12'
 - 2 pieces of 2x6 lumber - 24'
 - 21 pieces of 2x6 lumber - 16'
 - 36 pieces of 3/4" plywood - 48"x96"
 - 1 piece of 1/2" plywood - 4'x8'
 - 28 pieces of T1-11 5/8" siding - 4'x8'
 - 2 pieces of 2x4 lumber - 24'
 - 6 pieces of 2x4 lumber - 16'
 - 8 pieces of 2x4 lumber - 12'
 - 1 piece of 2x4 lumber - 10'

- 124 pieces of 2x4 lumber - 8'
- 6 pieces of 2x6 lumber - 8'
- 7 pieces of 2x6 lumber - 10'
- 13 pieces of 2x6 lumber - 16'
- 17 pieces of 1x4 lumber - 8'
- 3 pieces of 1x4 lumber - 16'
- 4 pieces of 1x4 lumber - 24'
- 1 kit of [shed hinges](#)+latch
- 300 pieces of [2 1/2" screws](#)
- 1500 pieces of [3 1/2" screws](#)
- 1500 pieces of [1 5/8" screws](#)
- 1500 pieces of 6d nails
- 700 sq ft of tar paper, 700 sq ft of asphalt shingles
- [wood filler](#), [wood glue](#), [stain/paint](#)
- 2 pieces of 3'x4' PVC window
- 1 piece of 32"x82" exterior door

Tools

 [Hammer, Tape measure, Framing square, Level](#)

 [Miter saw, Drill machinery, Screwdriver, Pocket hole jig, Sander](#)

 [Safety Gloves, Safety Glasses](#)

Time

 One week

Estimated Cost: 5000 usd

Make sure you [follow me on Facebook](#) to be the first that gets our latest plans and for some other exclusive content. Also, [follow me on Pinterest](#) to get many ideas for your backyard from all the internet! Check out our [YouTube channel](#)! See how you can [Support Me](#) with no extra costs to you.

Step 1: How to build a 16x24 shed floor

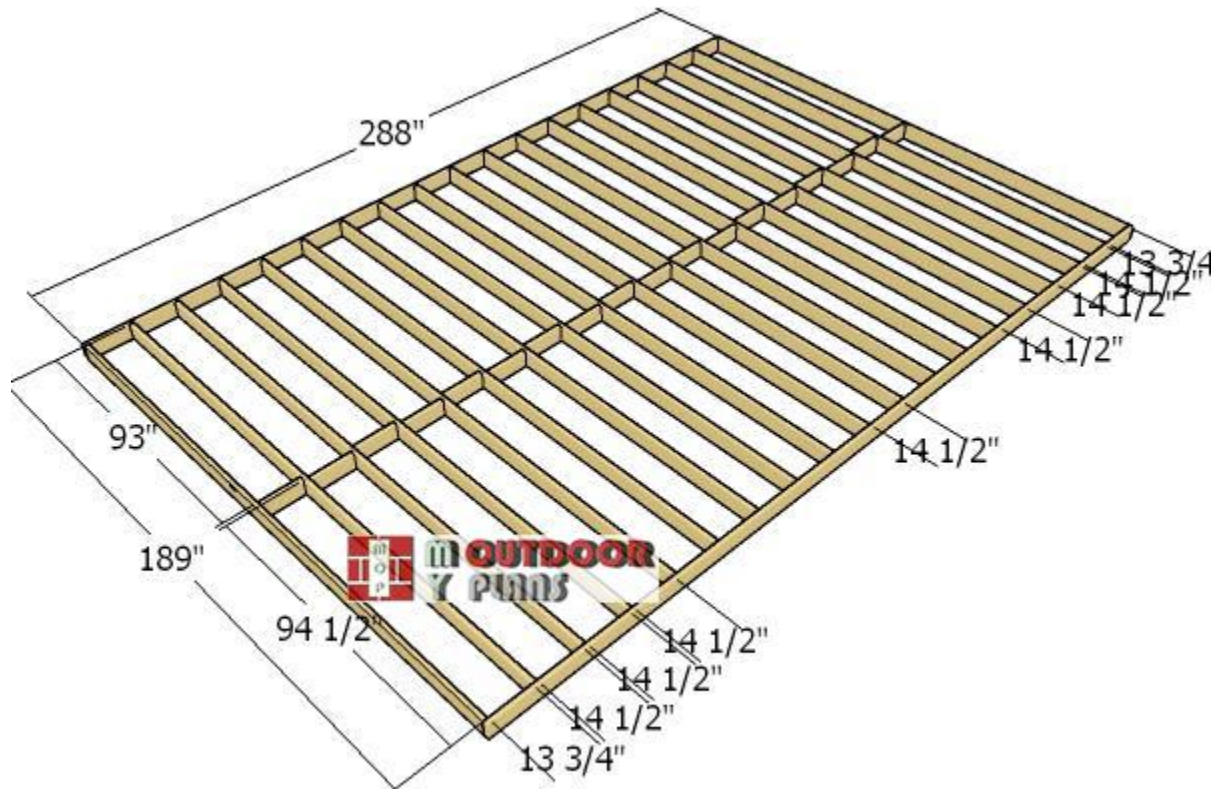

MyOutdoorPlans.com

Building-the-floor-frame-16x24-gambrel-shed

The first step of the project is to build the floor frame for the 16x24 shed. Cut the joists from 2x6 lumber at the right dimensions. Align the edges flush, drill pilot holes through the rim joists and insert 3 1/2" screws into the perpendicular components.

Place the joists every 16" on center. Fit 2x6 blockings between the joists, as show in the diagram, for a professional result. Measure the diagonals and make adjustments, if necessarily, until they are perfectly equal.

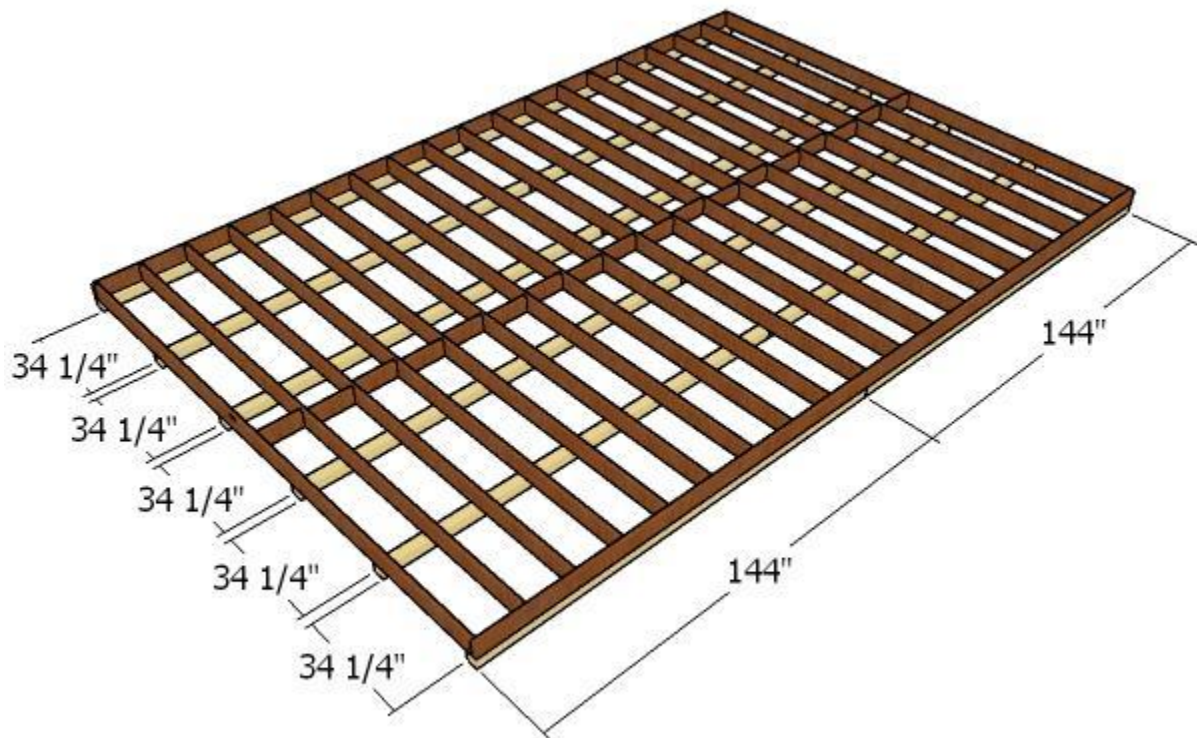

MyOutdoorPlans.com

Fitting the skids

Select the right location for the large gable shed and then level it. Compact a layer of gravel and then lay the 4x4 skids. Fit the floor frame to the skids and align the edges flush.

Use rafter ties to secure the frame to the skids. Leave no gaps between the components for a professional result. Use at least 2 ties for each skid and insert 1 1/2" structural screws.

MyOutdoorPlans.com

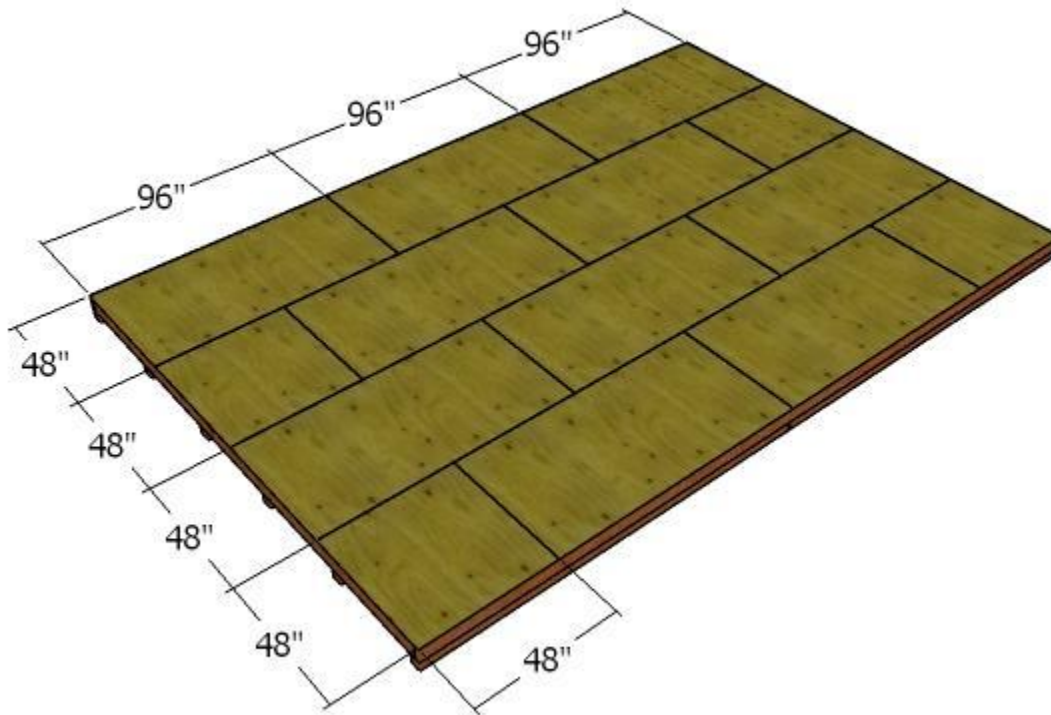

MyOutdoorPlans.com

Fitting the floor sheets

Fit the 3/4" plywood sheets to the floor frame. Align the edges flush and leave no gaps between the components. Drill pilot holes through the sheets and insert 1 5/8" screws, every 8", so you lock them into place tightly

MyOutdoorPlans.com

Step 2: How to build the shed wall frames

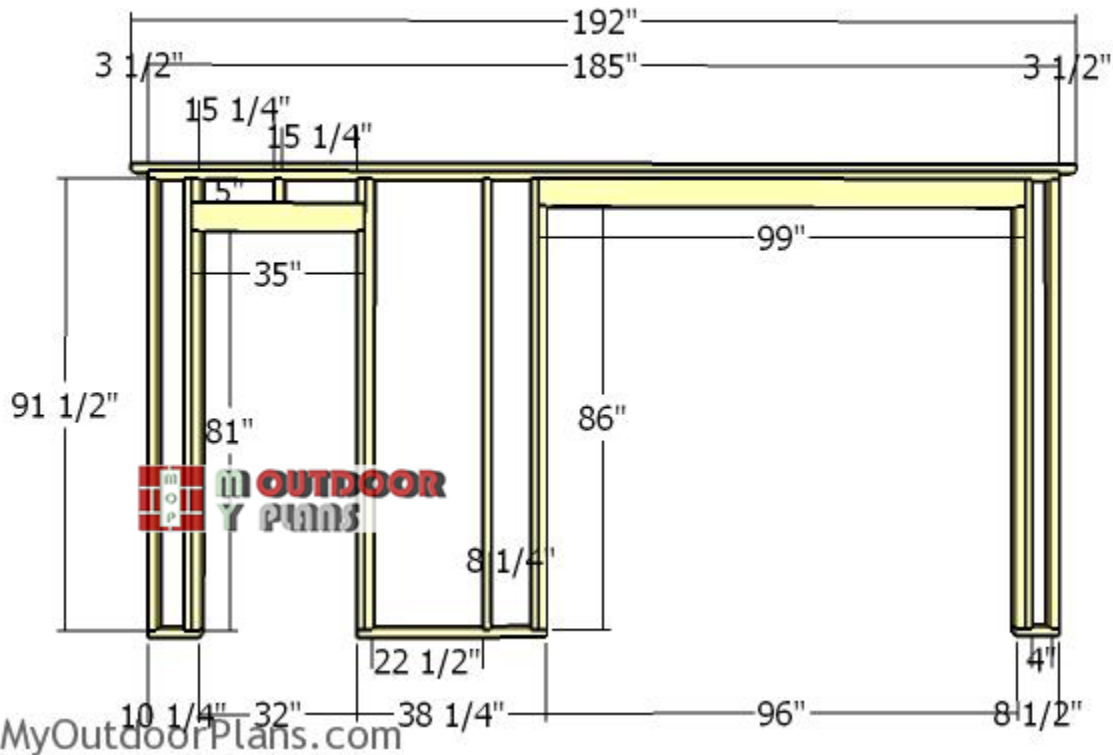

Building-the-wall-frame

The next step of the project is to build the wall frames for the shed. Start with the front wall, which has a large opening for the double doors and an opening for the single door. You can adjust the size of the small door opening, according to the size of the pre-hung door you are going to use.

Drill the pilot holes through the plates and insert 3 1/2" screws into the studs. Make sure the corners are square. Build the double header from 2x6 lumber and fit a piece of 1/2" plywood between the beams. Insert 2 1/2" screws from both sides and add glue so you can assemble the double headers.

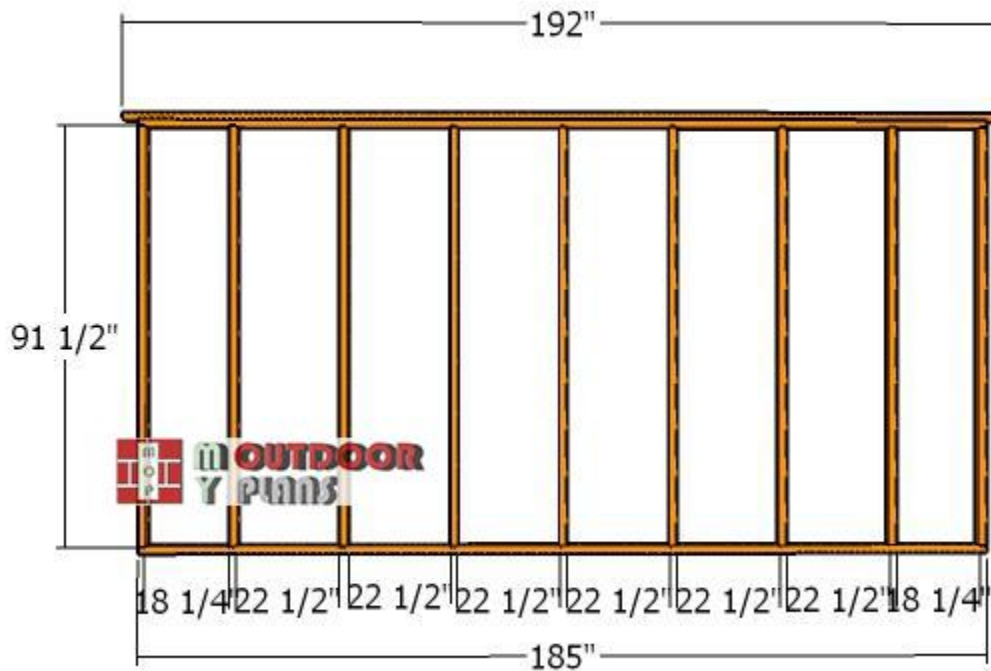

MyOutdoorPlans.com

Back-wall-frame

Next, you have to assemble the back wall for the 16x24 barn shed. Cut the components from 2x4 lumber and 3 1/2" screws. Place the studs every 24", so you can get a professional result. Center the double top plate and lock it into place with 3 1/2" screws.

The top plate overhangs 3 1/2" on both sides.

MyOutdoorPlans.com

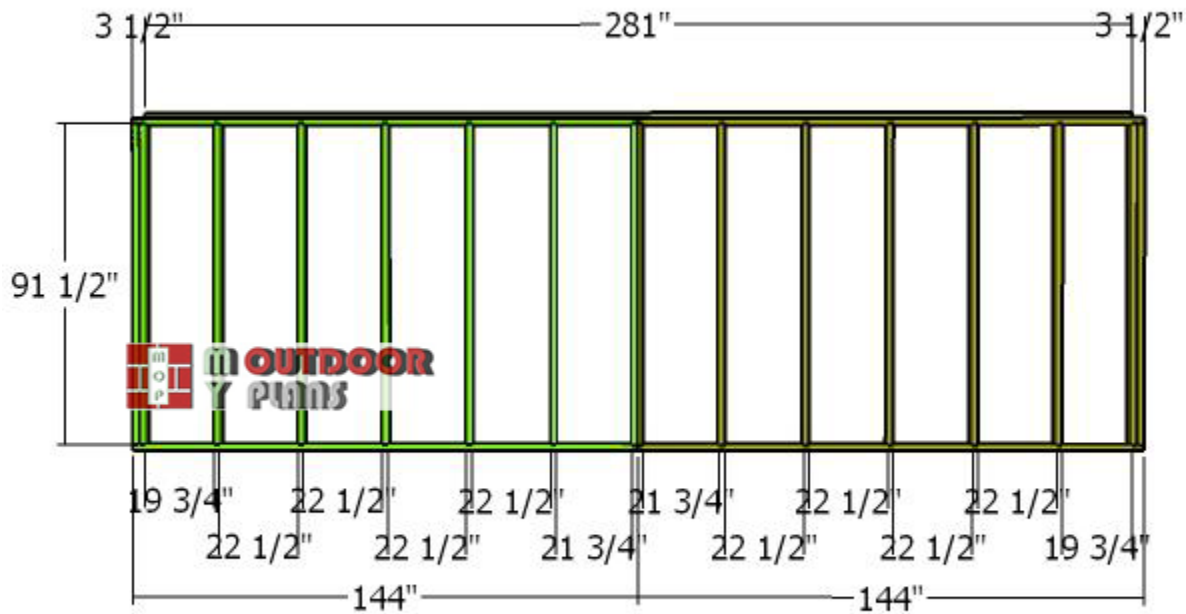

MyOutdoorPlans.com

Side-wall-frame

Build the plain side wall from 2x4 lumber. As you can easily notice in the plans, you need to build the wall from two sections.

In this manner, you can lift the walls easily and install them into place. The two sections are identical and joined together by the top plate.

Notice the double studs at both ends of the wall. Fit 1/2" plywood between the double studs.

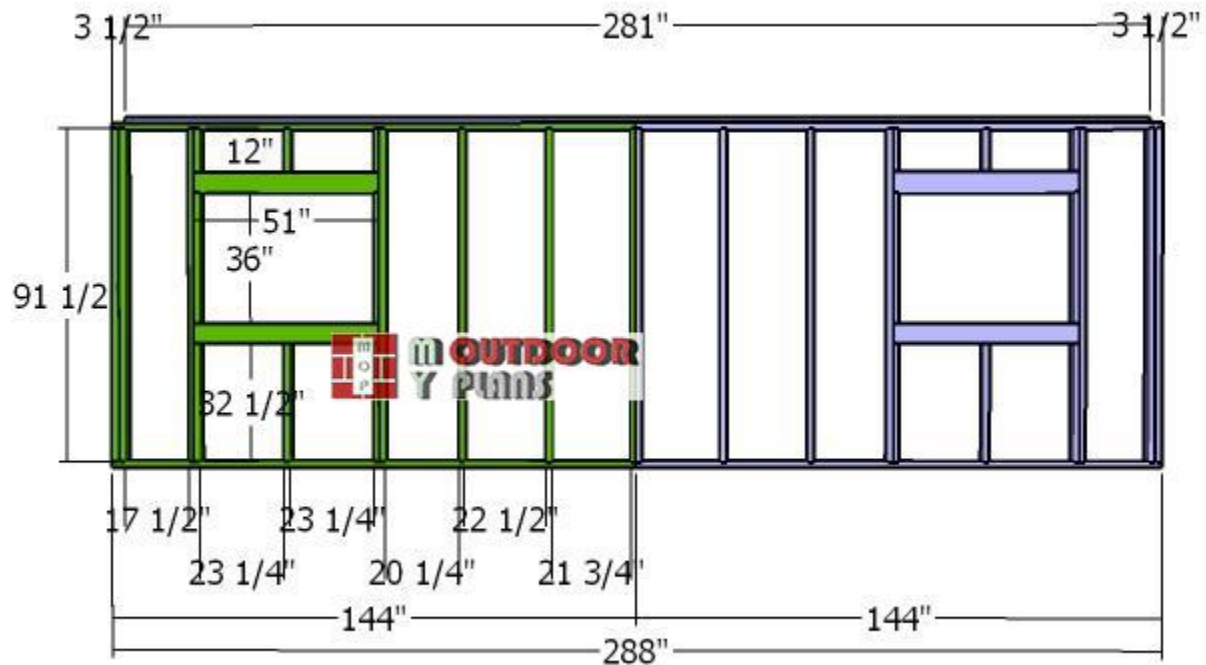

MyOutdoorPlans.com

Side-wall-with-window-and-door-frame

Build the side wall with windows from 2x4 lumber. Use 2x6 lumber for the double headers. Make two wall sections and then lock them together, once you have installed them into place.

You can adjust the size of the windows, so you get enough light inside the shed for your needs. You can adjust the size of the window opening from 3'x4' to another size.

Step 3: Assembling the shed frame



MyOutdoorPlans.com

Assembling the shed frame

Fit the wall frames to the floor of the shed. Align the edges flush and plumb them with a spirit level. Make sure the corners are square and lock them together tightly with 2 1/2" screws. Drill pilot holes through the bottom plates and insert 3 1/2" screws into the floor.

Step 4: Fitting the siding panels

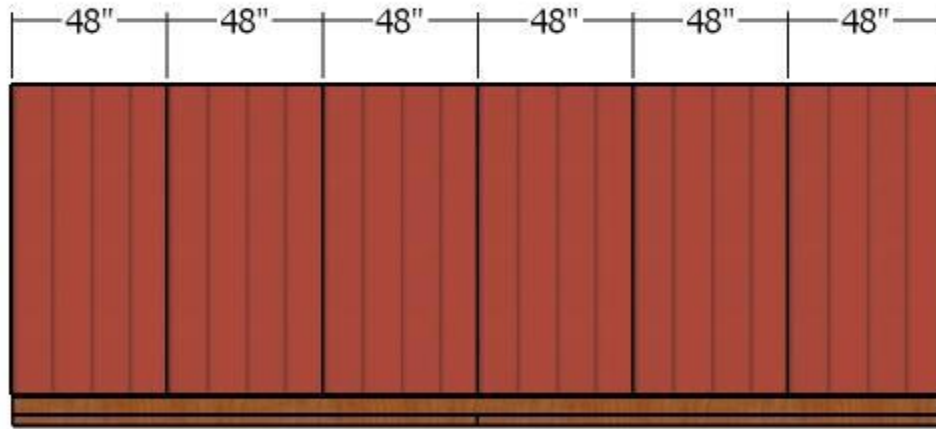

MyOutdoorPlans.com

Side wall - Siding

Fit the T1-11 siding sheets to the sides of the 16x24 barn shed. Align the sheet to the wall frame and lock it into place with 6-8d nails. Leave no gaps between the sheets and lock to the framing, every 8".

MyOutdoorPlans.com

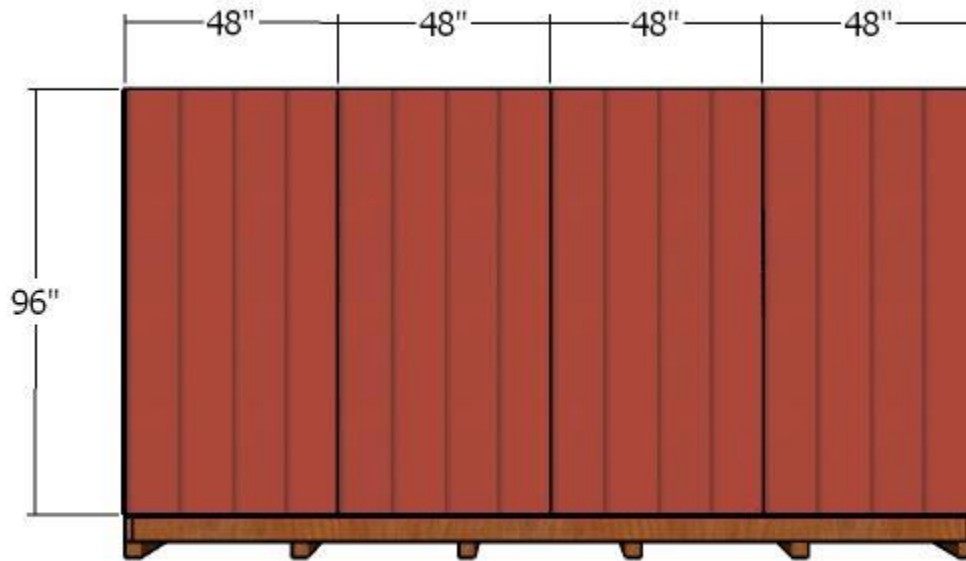

MyOutdoorPlans.com

Back wall - Siding

Fit the siding sheets to the back of the shed, as well. Align the sheets and leave no gaps between them. Use the same techniques described above.

MyOutdoorPlans.com

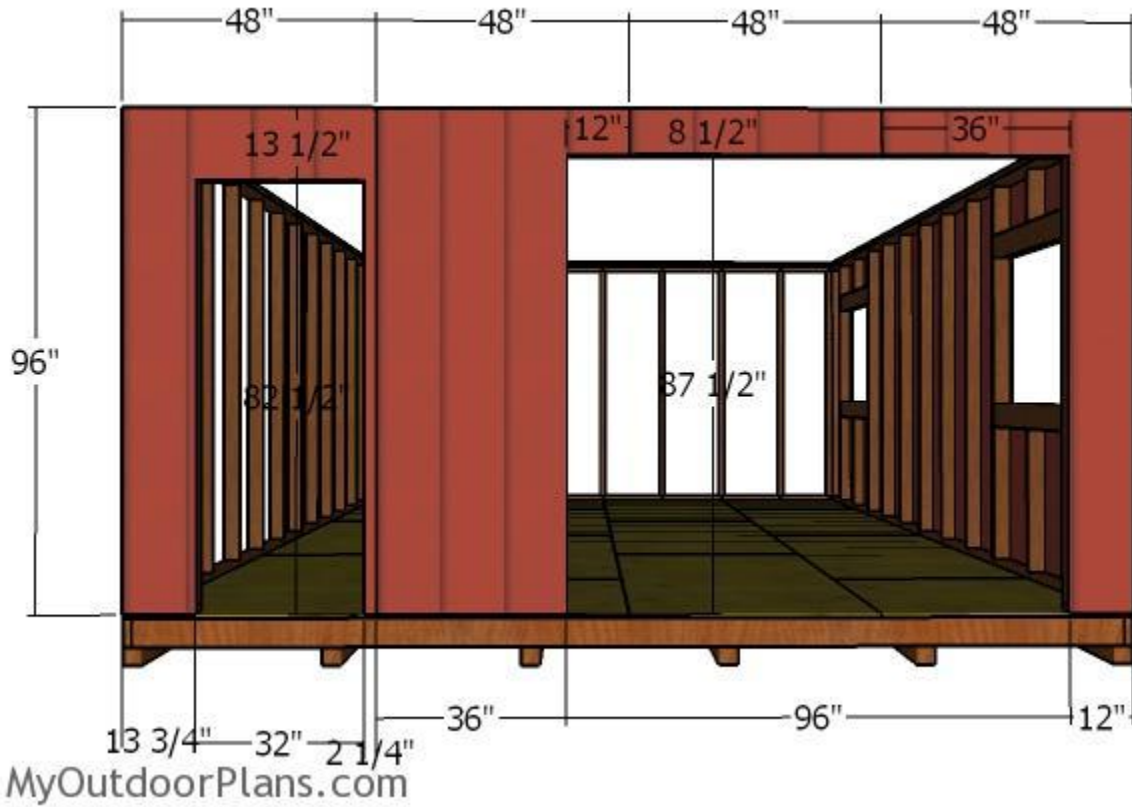

Front wall - Siding

Cut the siding sheets so they can fit around the door openings. Attach the sheets to the framing and lock them into place with 6-8d nails.

MyOutdoorPlans.com

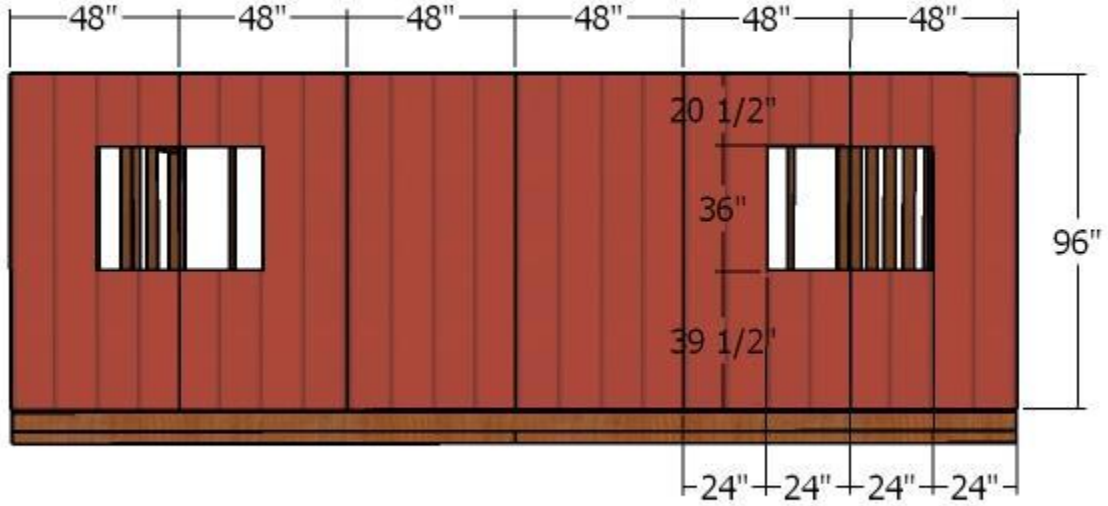

MyOutdoorPlans.com

Side wall with windows - Siding

Fit the siding sheets to the side wall with windows. Make the cuts so you clear the window openings.

MyOutdoorPlans.com

Step 5: Building the trusses

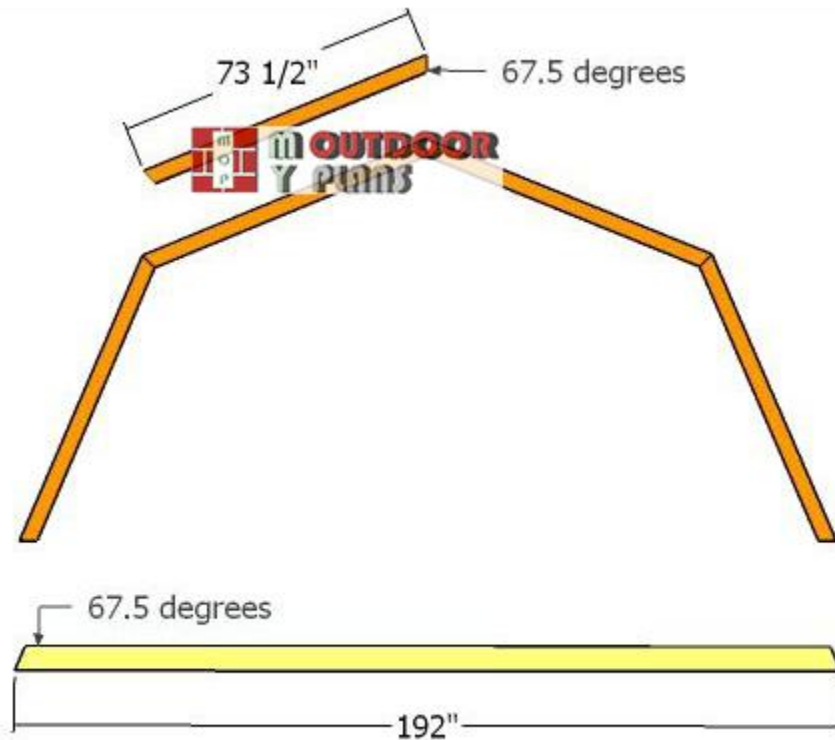

MyOutdoorPlans.com

Building-the-rafters

The first step of the project is to build the trusses for the gambrel shed. Use 2x4 lumber for the trusses and the 2x6 lumber for the bottom rafters. Make angle cuts to both ends of the rafters, as shown in the diagram.

Set the miter saw at 22.5 degrees and make the cuts. After you make the cuts, both ends of the rafters will have 67.5 degrees.

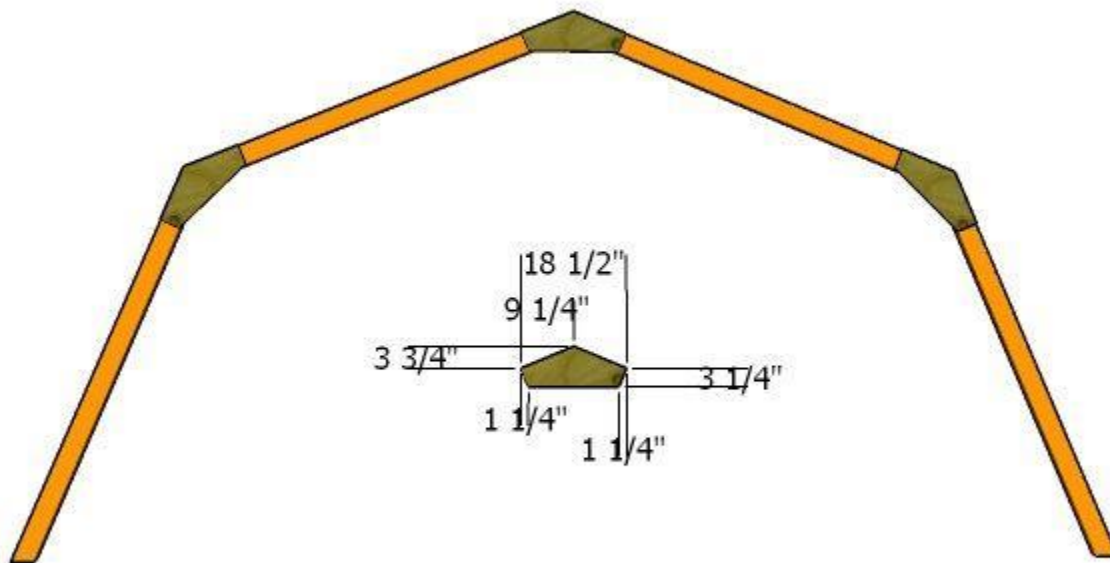

MyOutdoorPlans.com

Building the trusses

Use $\frac{1}{2}''$ plywood for the trusses and then fit them over the joints. Make cuts to the plywood with a saw and then lay them over the joints. Insert $1 \frac{5}{8}''$ screws to lock the gussets to the rafters. Ideally, you need to add gussets on both sides of the trusses.

MyOutdoorPlans.com

Step 6: Building the roof

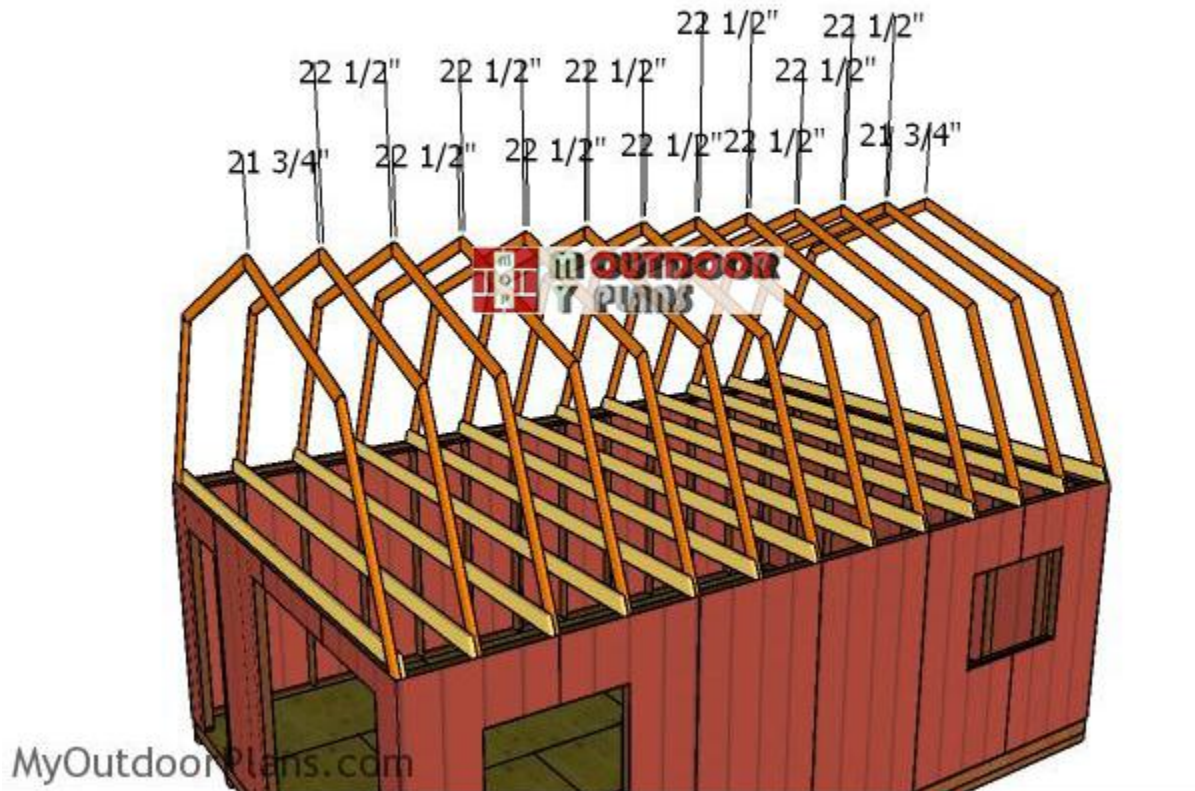

Fitting-the-trusses

Fit the trusses to the top of the shed, every 24" on center. Use a spirit level to plumb the trusses and then secure them into place with rafter ties and 1 1/2" structural screws.

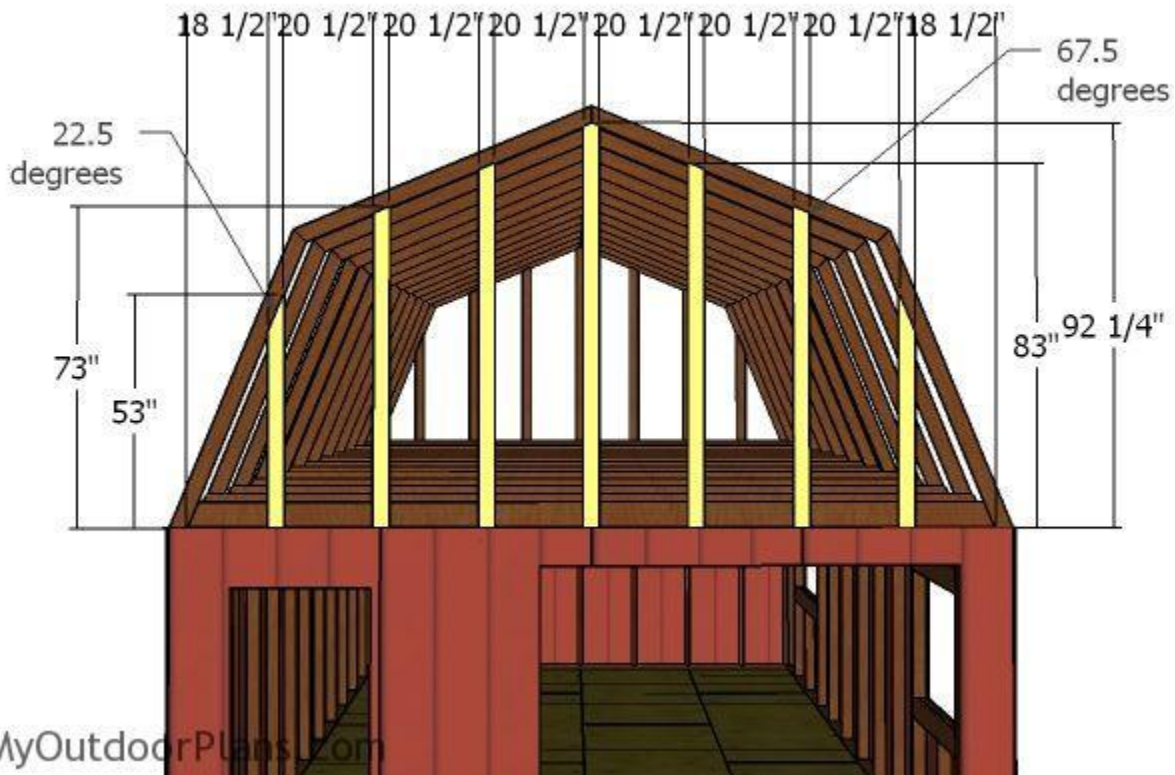

Fitting the gambrel end supports

Build the supports for the gambrel end from 2x4 lumber. Cut the supports at the right dimensions and then drill pocket holes at both ends of the supports. Insert 2 1/2" screws to secure the supports into place tightly.

For the long supports set the miter at 22.5 degrees. After you make the cut the support will have a 67.5 degree end.

For the short supports set the miter at 67.5 degrees. After you make the cut the support will have a 22.5 degree end.

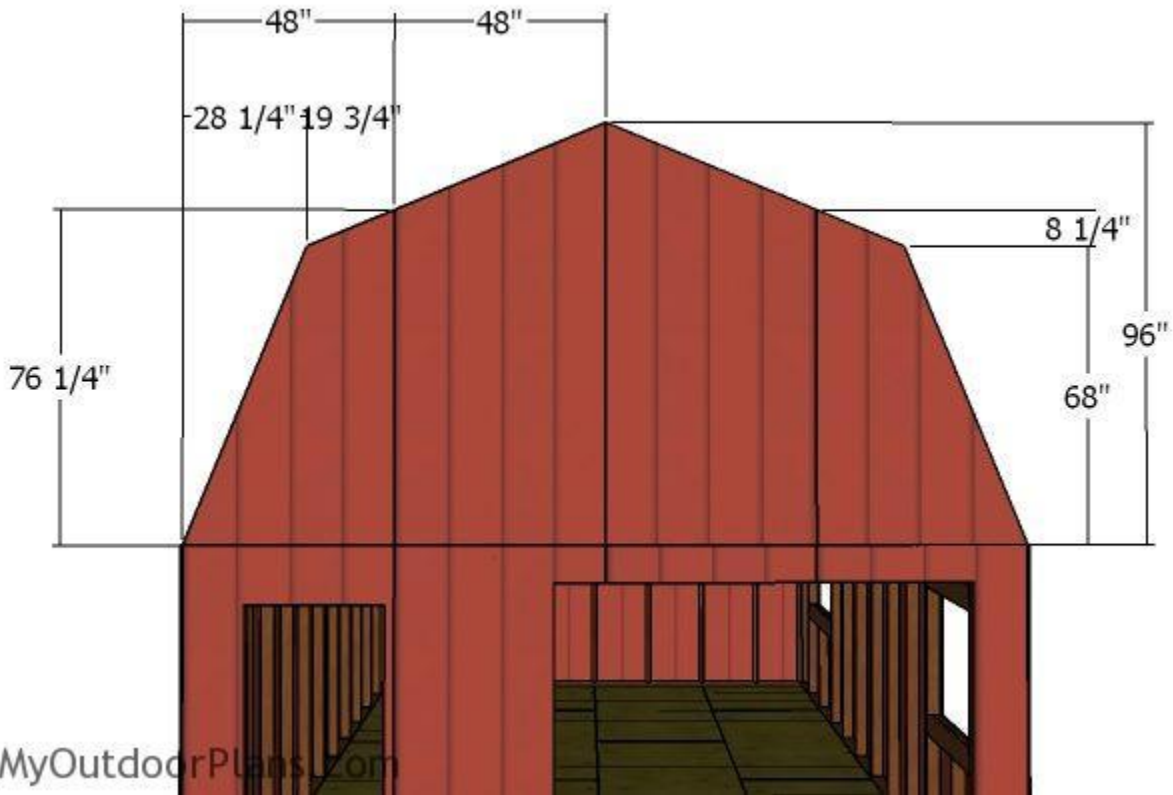

Gambrel end panels

Use T1-11 siding for the gambrel end panels. Use a saw to make the cuts and then secure them into place with 6-8d nails. Leave no gaps between the sheets for a professional result.

MyOutdoorPlans.com

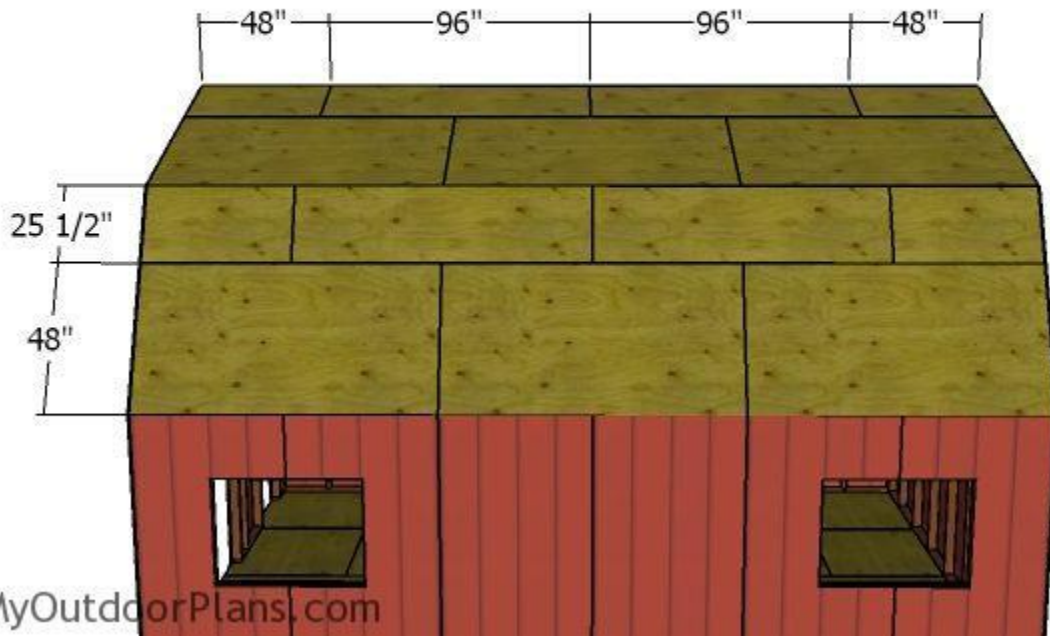

Fitting the roof sheets

Use 3/4" plywood for the roof sheets. Cut all the panels at the right size, as shown in the diagram and then lay them to the top of the roof.

Align the edges with attention, drill pilot holes and insert 1 5/8" screws to lock them into place, every 8" along the rafters. Leave no gaps between the sheets for a professional result.

Step 7: Fitting the roof trims

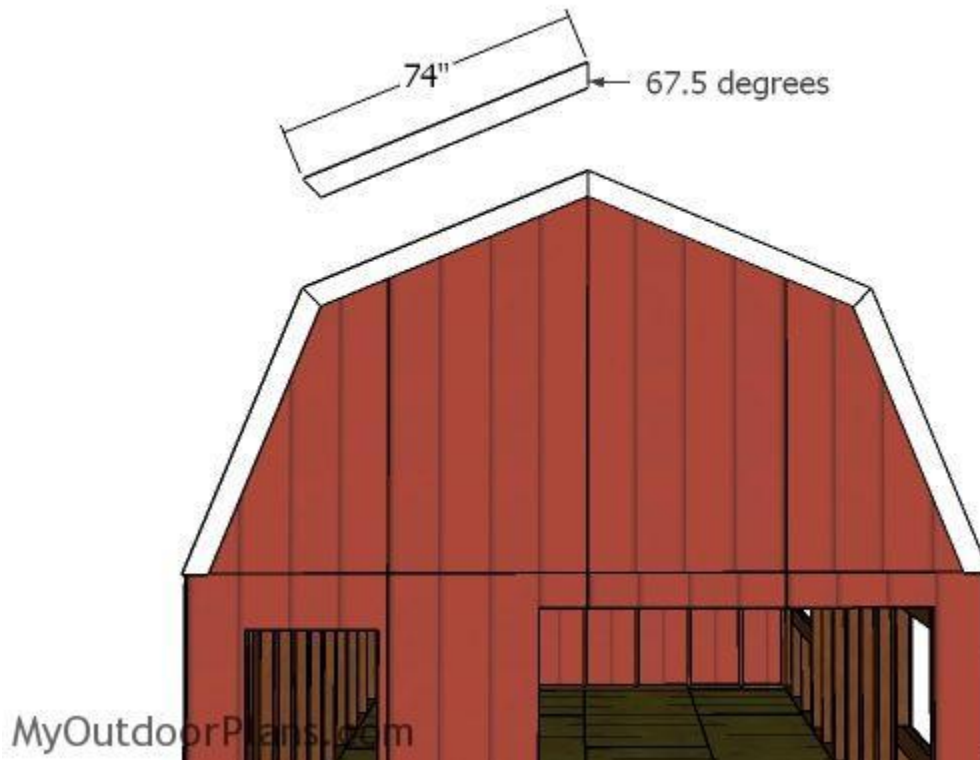

Roof trims

Use 2x6 lumber for the front and back roof trims. Make angle cuts to both ends of the trims and then secure them into place with 2 1/2" screws.

Set the miter saw at 22.5 degrees and make the cuts. Afterwards, both ends of the trims will have 67.5 degrees.

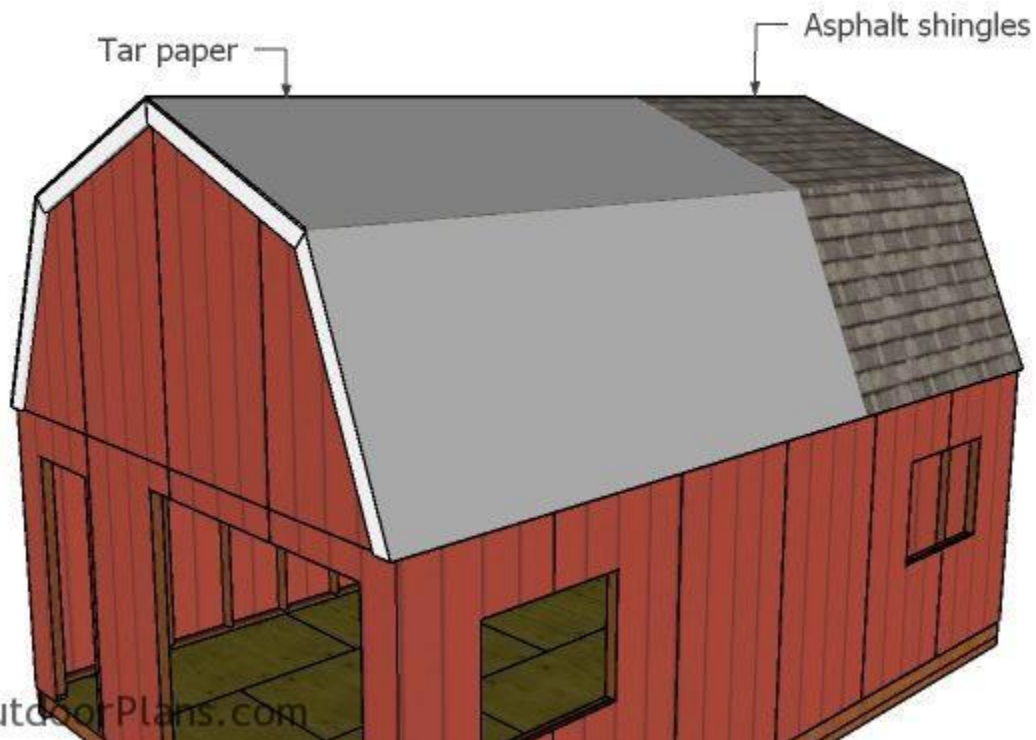

Fitting the roofing

Cover the roof of the shed with roofing felt, making sure the strips overlap at least 2". Secure the tar paper to the plywood sheets with roofing staples. In addition, cut a large piece for the top ridge. Fit the side drip edges over the roofing felt, while the bottom drip edges should be fit under.

Read the instructions labeled on the asphalt shingle packs before installing them into place tightly. Start with the bottom left side of the roof and install them all the way to the top.

Building double shed doors

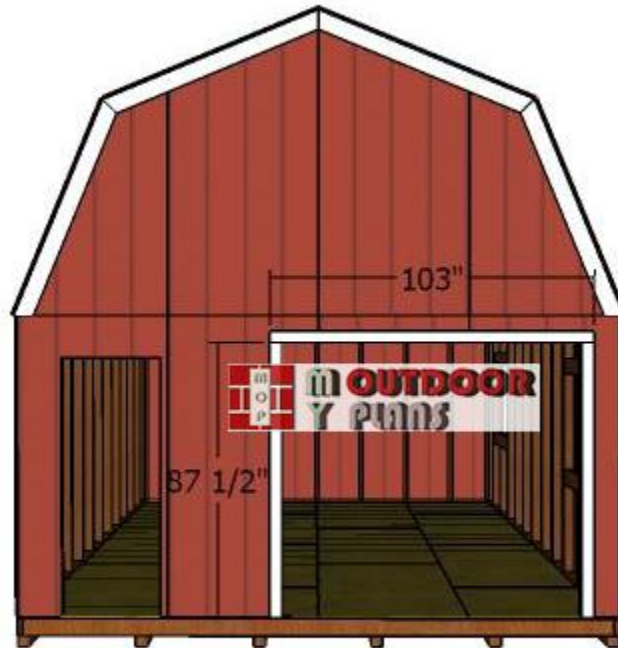

MyOutdoorPlans.com

Door-jambs

The first step of the project is to attach the 2x4 jambs to the door opening. Fit the jambs around the edges and then secure them into place with 2 1/2" screws.

MyOutdoorPlans.com

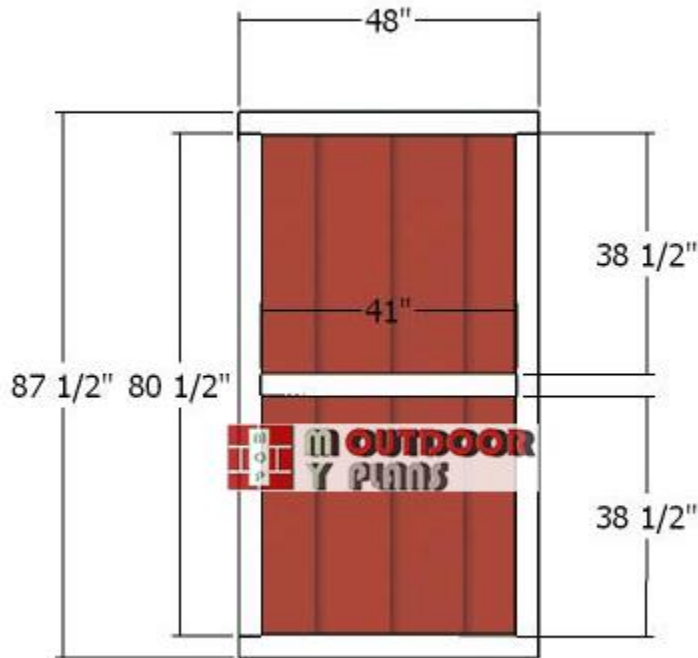

MyOutdoorPlans.com

Doors---shed

Build the doors from the T1-11 siding panels that you have cut out in the previous steps. Build the trims for the double doors from 2x4 lumber.

Drill pocket holes at both ends of the vertical and middle components. Join the frame together with 2 1/2" screws, making sure the corners are square.

Lay the door panels on a level surface and then attach the trims into place tightly. Use glue and 1 5/8" screws to lock the panel to the door frame.

Align the edges flush and smooth them with attention.

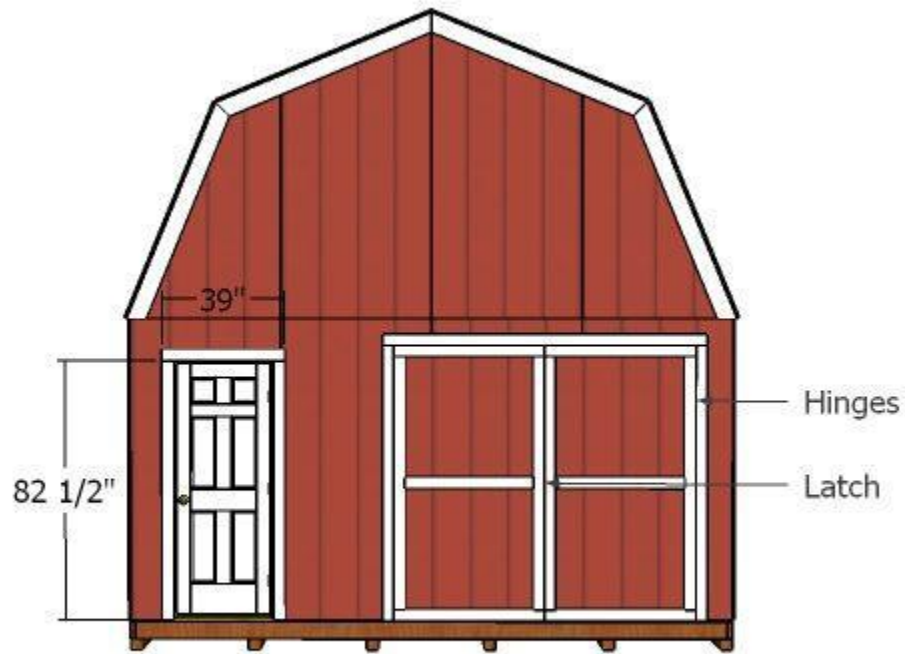

MyOutdoorPlans.com

Fitting the double doors

Fit the double doors to the front opening and secure them into place with hinges. Moreover, you need to install a latch so you can lock the doors into place. Install handles so you can open and close the doors easily.

MyOutdoorPlans.com



MyOutdoorPlans.com

Side wall trims

Fit the 1x4 trims to the sides of the barn shed. Align the edges flush and then secure them into place with 2" nails. Fit the trims around the windows, as well.

MyOutdoorPlans.com

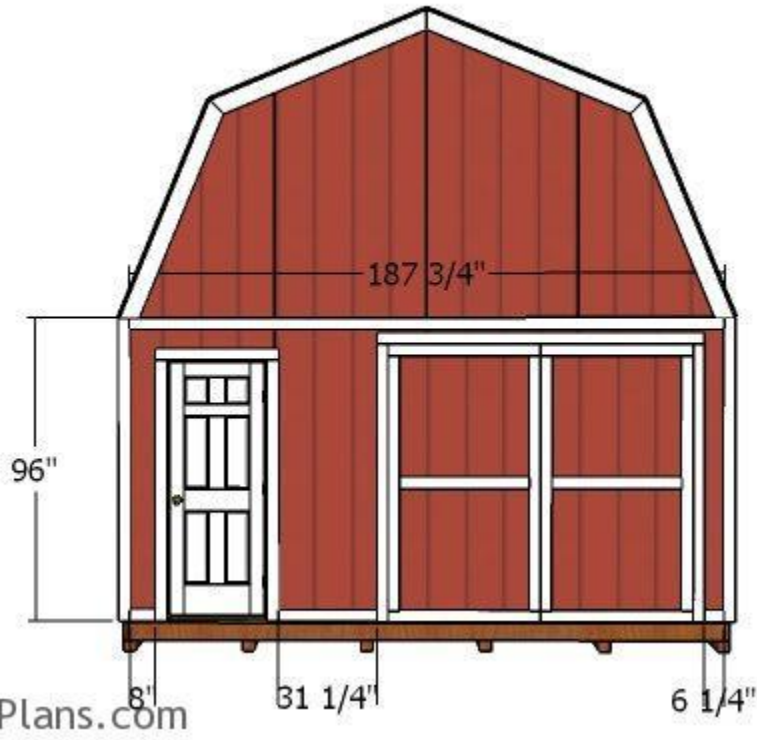

Front trims

Fit the 1x4 trims to the front of the barn shed, to enhance the look of the project.

MyOutdoorPlans.com

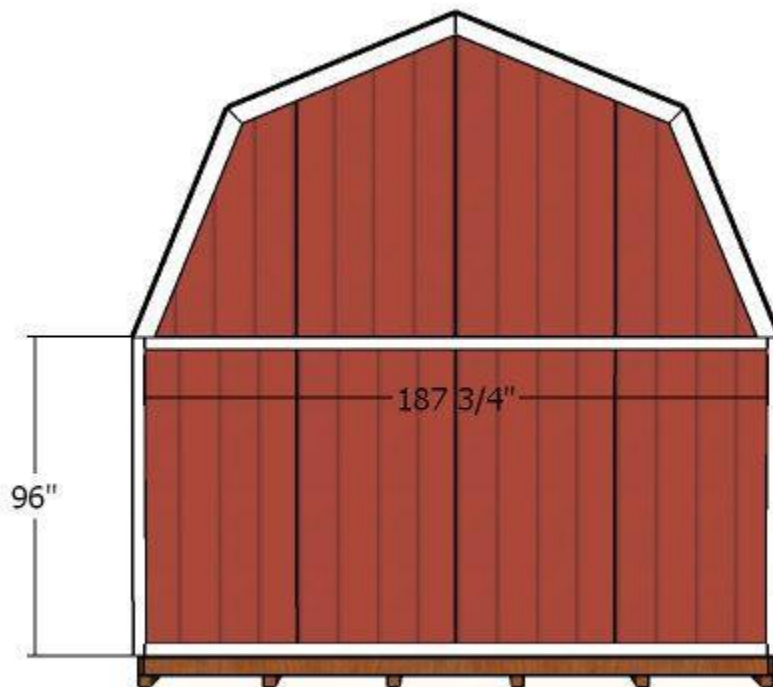

MyOutdoorPlans.com

Back wall trims

Fit the 1x4 trims to the back of the shed as well. Align the edges flush and then secure them into place with 2" nails. Leave no gaps between the trims for a professional result.

MyOutdoorPlans.com



MyOutdoorPlans.com

16x24 Barn Shed Plans

This 16x24 shed requires a significant investment in terms of time and money, so make sure you prepare it appropriately. If you are looking for a different design, make sure you take a look over all my shed plans [HERE](#).

MyOutdoorPlans.com