

Anchors per code

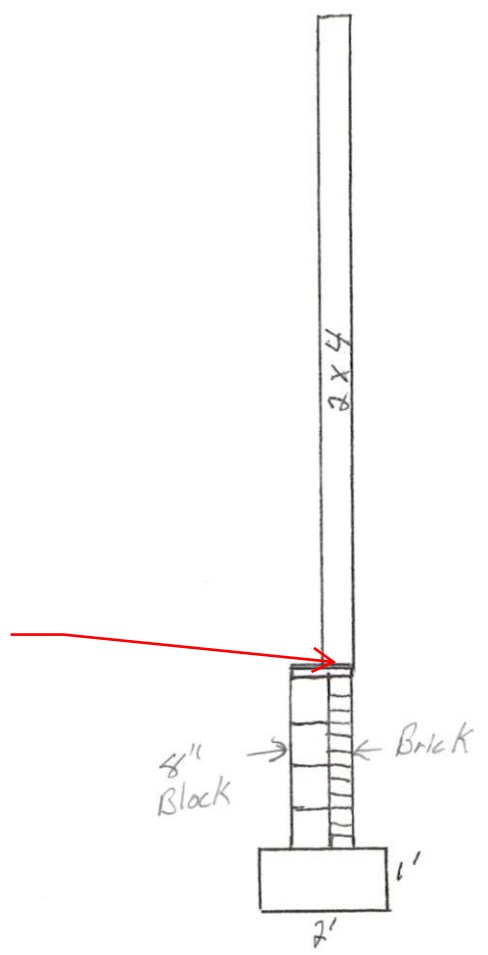

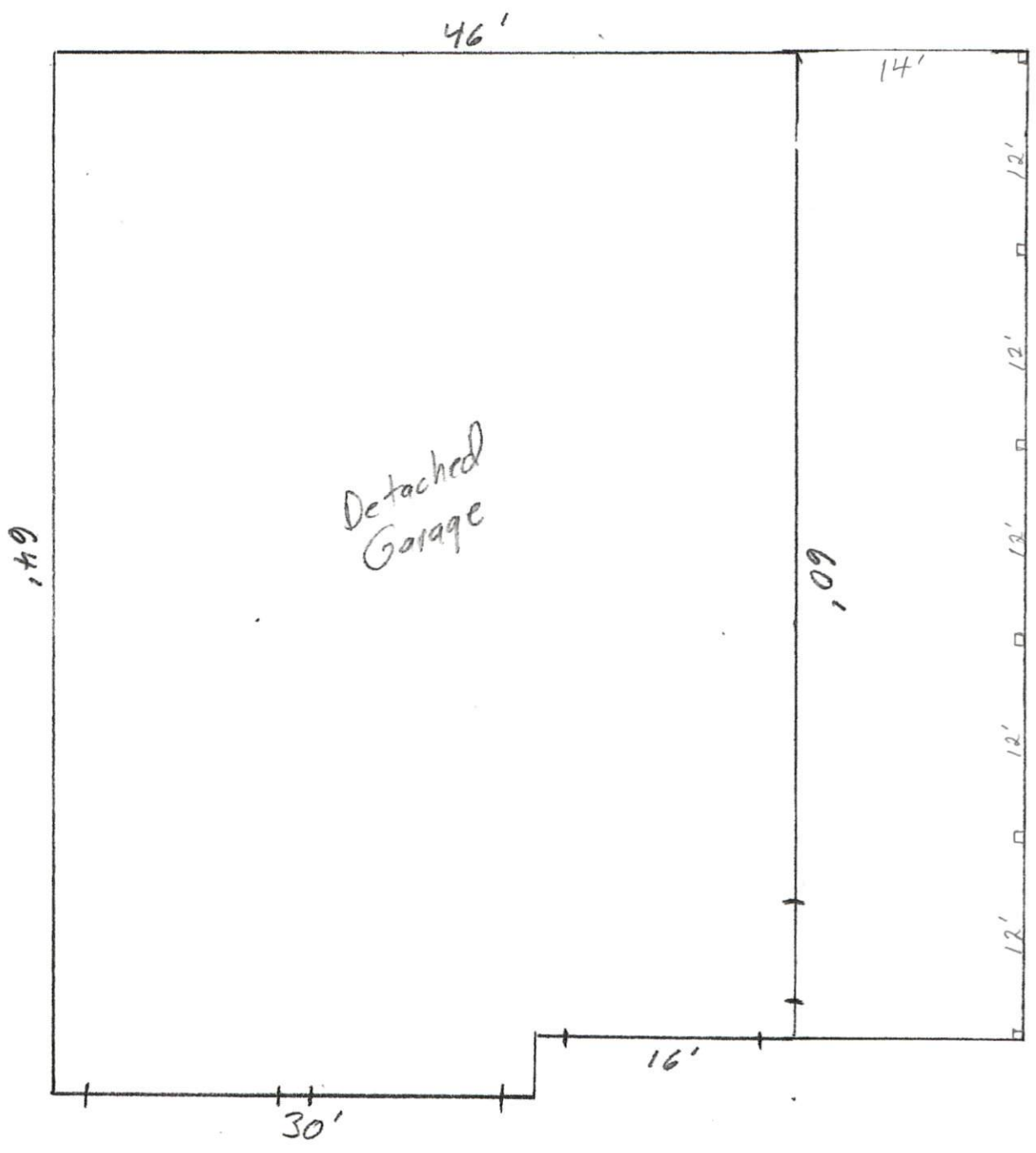

Job J1124-6098	Truss A1	Truss Type Piggyback Base	Qty 29	Ply 1	Southern Concrete
Comtech, Inc., Fayetteville, NC 28309, David Simonson					Job Reference (optional)

Run: 8.630 s Jul 12 2024 Print: 8.630 s Jul 12 2024 MiTek Industries, Inc. Mon Nov 11 10:59:00 2024 Page 1
ID: Rv_0MPgPYr2mSaUtDo4oxyKIDC-IVzEfw?Ty0uBBFWrhAWUEPwz9BgdcP0hrMi76JyKHw

-0-10-8	9-3-12	17-10-12	23-0-0	28-1-4	36-8-4	46-0-0	46-10-8
0-10-8	9-3-12	8-7-0	5-1-4	5-1-4	8-7-0	9-3-12	0-10-8

Scale = 1:78.1

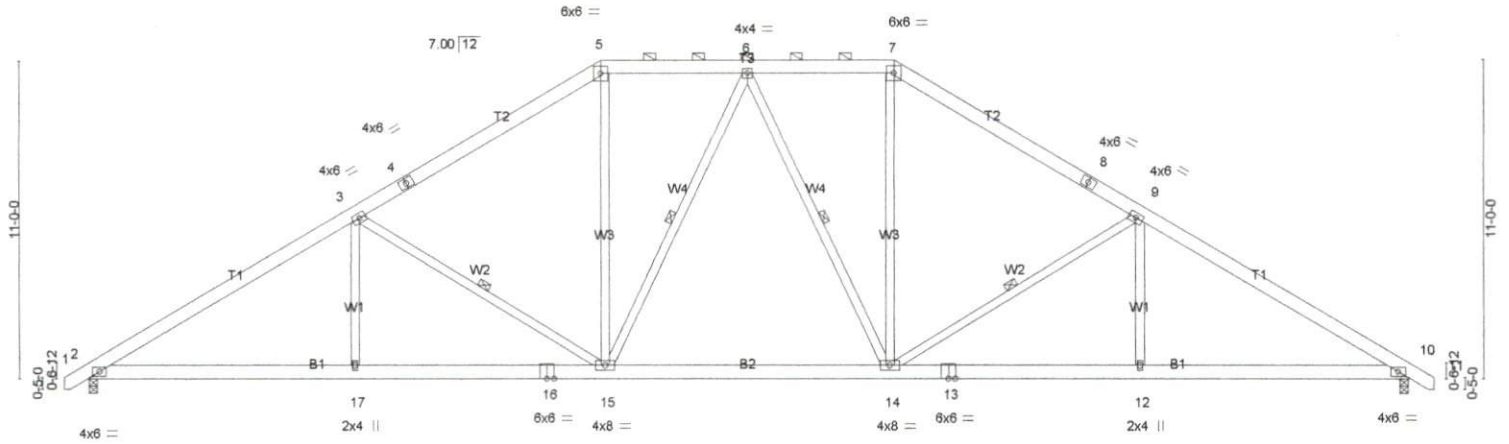

9-3-12	17-10-12	28-1-4	36-8-4	46-0-0
9-3-12	8-7-0	10-2-9	8-7-0	9-3-12

LOADING (psf)	SPACING-	CSI.	DEFL.	PLATES	GRIP
TCLL 20.0	2-0-0	TC 0.28	in (loc) l/def L/d	MT20	244/190
TCDL 10.0	Plate Grip DOL 1.15	BC 0.56	Vert(LL) -0.24 14-15 >999 360		
BCLL 0.0 *	Lumber DOL 1.15	WB 0.47	Vert(CT) -0.38 14-15 >999 240		
BCDL 10.0	Rep Stress Incr YES	Matrix-AS	Horz(CT) 0.11 10 n/a n/a		
	Code IRC2015/TPI2014		Wind(LL) 0.08 14-15 >999 240		
				Weight: 341 lb	FT = 25%

LUMBER-

TOP CHORD 2x6 SP No.1
BOT CHORD 2x6 SP No.1
WEBS 2x4 SP No.2

BRACING-

TOP CHORD Structural wood sheathing directly applied, except
2-0-0 oc purlins (5-3-6 max.): 5-7.
BOT CHORD Rigid ceiling directly applied.
WEBS 1 Row at midpt 3-15, 6-15, 6-14, 9-14

MiTek recommends that Stabilizers and required cross bracing be installed during truss erection, in accordance with Stabilizer Installation guide.

REACTIONS. (lb/size) 2=1887/0-3-8 (min. 0-2-7), 10=1887/0-3-8 (min. 0-2-7)

Max Horz 2=-262(LC 10)
Max Uplift 2=-91(LC 12), 10=-91(LC 13)
Max Grav 2=2055(LC 19), 10=2055(LC 20)

FORCES. (lb) - Max. Comp./Max. Ten. - All forces 250 (lb) or less except when shown.

TOP CHORD 2-24=-3371/640, 3-24=-3303/673, 3-4=-2600/594, 4-5=-2483/641, 5-25=-2153/632,
6-25=-2153/632, 6-26=-2153/632, 7-26=-2153/632, 7-8=-2483/641, 8-9=-2600/594,
9-27=-3304/673, 10-27=-3371/640
BOT CHORD 2-28=-444/3020, 17-28=-444/3020, 17-29=-444/3020, 16-29=-444/3020, 15-16=-444/3020,
15-30=-227/2197, 30-31=-227/2197, 14-31=-227/2197, 13-14=-448/2852, 13-32=-448/2852,
12-32=-448/2852, 12-33=-448/2852, 10-33=-448/2852
WEBS 3-17=0/418, 3-15=-996/290, 5-15=-109/900, 6-15=-313/198, 6-14=-313/198, 7-14=-109/900,
9-14=-997/290, 9-12=0/418

NOTES-

- Unbalanced roof live loads have been considered for this design.
- Wind: ASCE 7-10; Vult=130mph Vasd=103mph; TCDL=6.0psf; BCDL=6.0psf; h=15ft; Cat. II; Exp C; Enclosed; MWFRS (envelope) and C-C Exterior(2) -0-9-5 to 3-9-14, Interior(1) 3-9-14 to 17-10-12, Exterior(2) 17-10-12 to 24-4-13, Interior(1) 24-4-13 to 28-1-4, Exterior(2) 28-1-4 to 34-7-5, Interior(1) 34-7-5 to 46-9-5 zone; C-C for members and forces & MWFRS for reactions shown; Lumber DOL=1.60 plate grip DOL=1.60
- Provide adequate drainage to prevent water ponding.
- This truss has been designed for a 10.0 psf bottom chord live load nonconcurrent with any other live loads.
- * This truss has been designed for a live load of 30.0psf on the bottom chord in all areas where a rectangle 3-6-0 tall by 2-0-0 wide will fit between the bottom chord and any other members, with BCDL = 10.0psf.
- Provide mechanical connection (by others) of truss to bearing plate capable of withstanding 91 lb uplift at joint 2 and 91 lb uplift at joint 10.
- This truss is designed in accordance with the 2015 International Residential Code sections R502.11.1 and R802.10.2 and referenced standard ANSI/TPI 1.

Job J1124-6098	Truss A1	Truss Type Piggyback Base	Qty 29	Ply 1	Southern Concrete
--------------------------	--------------------	-------------------------------------	------------------	-----------------	--------------------------

Comtech, Inc., Fayetteville, NC 28309, David Simonson

Run: 8.630 s Jul 12 2024 Print: 8.630 s Jul 12 2024 MiTek Industries, Inc. Mon Nov 11 10:59:00 2024 Page 2
ID:Rv_OMPgPYYr2mSaUtDo4oxyKIDO-IVzEfw?Ty0uBBFWrhAWUJEPwz9BgdcP0hrMi76JyKHwv

Job Reference (optional)

- NOTES-**
- 8) This truss design requires that a minimum of 7/16" structural wood sheathing be applied directly to the top chord and 1/2" gypsum sheetrock be applied directly to the bottom chord.
 - 9) Graphical purlin representation does not depict the size or the orientation of the purlin along the top and/or bottom chord.

LOAD CASE(S) Standard

-0-10-8	17-10-12	28-1-4	46-0-0	46-10-8
0-10-8	17-10-12	10-2-9	17-10-12	0-10-8

Scale = 1:79.0

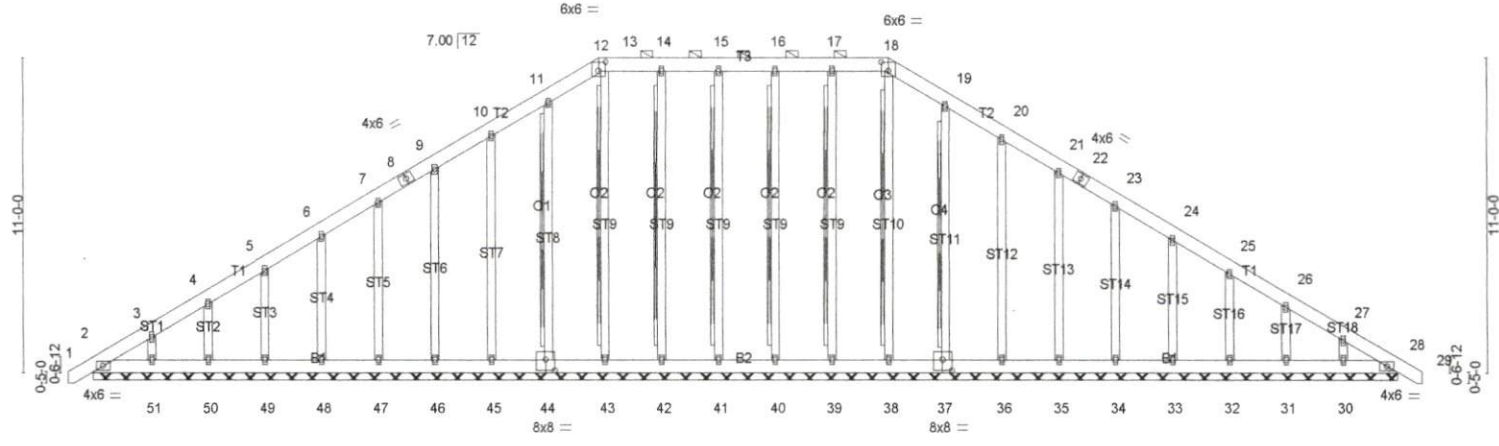

46-0-0
46-0-0

Plate Offsets (X,Y)-- [12:0-3-0,0-3-12], [18:0-3-0,0-3-12], [37:0-4-0,0-4-8], [44:0-4-0,0-4-8]

LOADING (psf)	SPACING-	2-0-0	CSI.	DEFL.		PLATES	GRIP
TCLL 20.0	Plate Grip DOL	1.15	TC 0.05	Vert(LL) 0.00	28 n/r 120	MT20	244/190
TCDL 10.0	Lumber DOL	1.15	BC 0.02	Vert(CT) 0.00	28 n/r 120		
BCLL 0.0 *	Rep Stress Incr	YES	WB 0.17	Horz(CT) 0.01	28 n/a n/a		
BCDL 10.0	Code IRC2015/TPI2014		Matrix-S				
						Weight: 441 lb	FT = 25%

<p>LUMBER- TOP CHORD 2x6 SP No.1 BOT CHORD 2x6 SP No.1 OTHERS 2x4 SP No.2</p>	<p>BRACING- TOP CHORD Structural wood sheathing directly applied or 6-0-0 oc purlins, except 2-0-0 oc purlins (6-0-0 max.): 12-18. BOT CHORD Rigid ceiling directly applied or 10-0-0 oc bracing. WEBS T-Brace: 2x4 SPF No.2 - 18-38, 17-39, 16-40, 15-41, 14-42, 13-43, 11-44, 19-37 Fasten (2X) T and I braces to narrow edge of web with 10d (0.131"x3") nails, 6in o.c., with 3in minimum end distance. Brace must cover 90% of web length.</p> <div style="border: 1px solid black; padding: 5px; margin-top: 5px;"> <p>MiTek recommends that Stabilizers and required cross bracing be installed during truss erection, in accordance with Stabilizer Installation guide.</p> </div>
---	--

REACTIONS. All bearings 46-0-0.
 (lb) - Max Horz 2=-328(LC 10)
 Max Uplift All uplift 100 lb or less at joint(s) 2, 39, 40, 41, 42, 43, 44, 45, 46, 47, 48, 49, 50, 51, 37, 36, 35, 34, 33, 32, 31, 30, 28
 Max Grav All reactions 250 lb or less at joint(s) 2, 38, 39, 40, 41, 42, 43, 44, 45, 46, 47, 48, 49, 50, 51, 37, 36, 35, 34, 33, 32, 31, 30, 28

FORCES. (lb) - Max. Comp./Max. Ten. - All forces 250 (lb) or less except when shown.
 TOP CHORD 2-3=-310/265, 9-10=-184/251, 10-11=-238/291, 11-12=-272/318, 12-13=-255/304, 13-14=-255/304, 14-15=-255/304, 15-16=-255/304, 16-17=-255/304, 17-18=-255/304, 18-19=-276/321, 19-20=-235/270

- NOTES-**
- 1) Unbalanced roof live loads have been considered for this design.
 - 2) Wind: ASCE 7-10; Vult=130mph Vasd=103mph; TCDL=6.0psf; BCDL=6.0psf; h=15ft; Cat. II; Exp C; Enclosed; MWFRS (envelope) gable end zone and C-C Corner(3) -0-9-5 to 4-1-4, Exterior(2) 4-1-4 to 17-10-12, Corner(3) 17-10-12 to 22-5-15, Exterior(2) 22-5-15 to 28-1-4, Corner(3) 28-1-4 to 32-8-8, Exterior(2) 32-8-8 to 46-9-5 zone; C-C for members and forces & MWFRS for reactions shown; Lumber DOL=1.60 plate grip DOL=1.60
 - 3) Truss designed for wind loads in the plane of the truss only. For studs exposed to wind (normal to the face), see Standard Industry Gable End Details as applicable, or consult qualified building designer as per ANSI/TPI 1.
 - 4) Provide adequate drainage to prevent water ponding.
 - 5) All plates are 2x4 MT20 unless otherwise indicated.
 - 6) Gable requires continuous bottom chord bearing.
 - 7) Gable studs spaced at 2-0-0 oc.
 - 8) This truss has been designed for a 10.0 psf bottom chord live load nonconcurrent with any other live loads.

Job J1124-6098	Truss A1GE	Truss Type PIGGYBACK BASE SUPP	Qty 1	Ply 1	Southern Concrete
--------------------------	----------------------	--	-----------------	-----------------	--------------------------

Comtech, Inc., Fayetteville, NC 28309, David Simonson

Run: 8.630 s Jul 12 2024 Print: 8.630 s Jul 12 2024 MiTek Industries, Inc. Mon Nov 11 10:59:01 2024 Page 2
ID:Rv_0MPgPYYr2mSaUtDo4oxyKIDO-mhXcsG?5jK02pP51Ft1jndTCdb8ELxxq30RgelyKHwu

Job Reference (optional)

NOTES-

- 9) * This truss has been designed for a live load of 30.0psf on the bottom chord in all areas where a rectangle 3-6-0 tall by 2-0-0 wide will fit between the bottom chord and any other members.
- 10) Provide mechanical connection (by others) of truss to bearing plate capable of withstanding 100 lb uplift at joint(s) 2, 39, 40, 41, 42, 43, 44, 45, 46, 47, 48, 49, 50, 51, 37, 36, 35, 34, 33, 32, 31, 30, 28.
- 11) This truss is designed in accordance with the 2015 International Residential Code sections R502.11.1 and R802.10.2 and referenced standard ANSI/TPI 1.
- 12) Graphical purlin representation does not depict the size or the orientation of the purlin along the top and/or bottom chord.
- 13) Warning: Additional permanent and stability bracing for truss system (not part of this component design) is always required.

LOAD CASE(S) Standard

Job J1124-6098	Truss A1SGE	Truss Type GABLE	Qty 1	Ply 1	Southern Concrete
--------------------------	-----------------------	----------------------------	-----------------	-----------------	--------------------------

Comtech, Inc., Fayetteville, NC 28309, David Simonson

Run: 8.630 s Jul 12 2024 Print: 8.630 s Jul 12 2024 MiTek Industries, Inc. Mon Nov 11 10:59:02 2024 Page 1
ID:Rv_0MPgPYr2mSaUtDo4oxyKIDO-Fu4_4c0Ue8vQZgDobZyKq0Jf?L54JKzIfBDBByKHwt

-0-10-8	9-3-12	17-10-12	23-0-0	28-1-4	36-8-4	46-0-0	46-10-8
0-10-8	9-3-12	8-7-0	5-1-4	5-1-4	8-7-0	9-3-12	0-10-8

Scale = 1:78.1

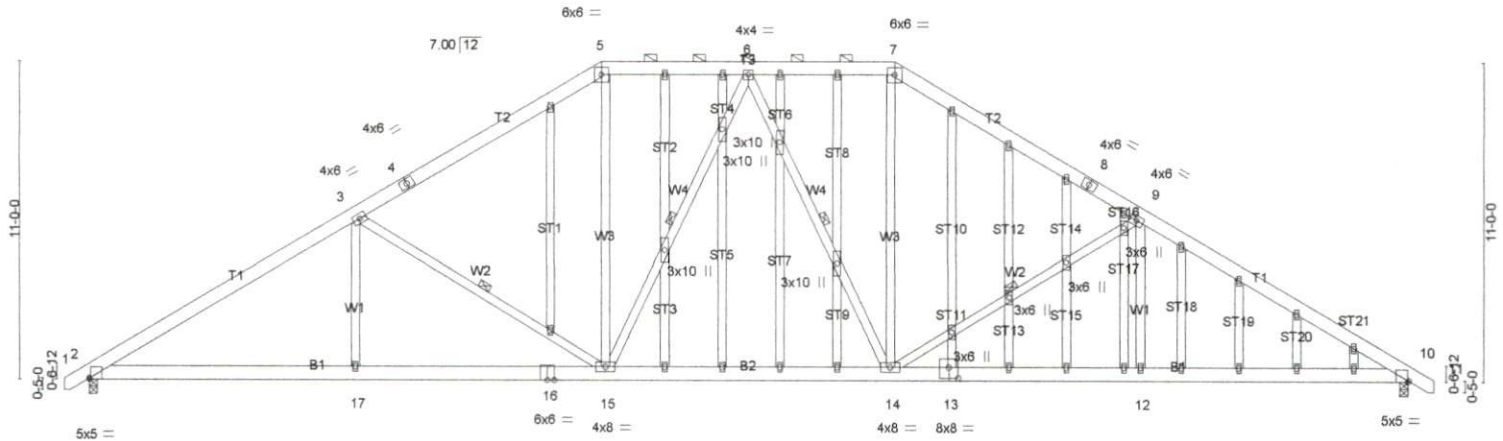

9-3-12	17-10-12	28-1-4	36-8-4	46-0-0
9-3-12	8-7-0	10-2-9	8-7-0	9-3-12

Plate Offsets (X,Y)-- [2:0-0-6,Edge], [10:0-0-6,Edge], [13:0-4-0,0-4-8]

LOADING (psf)	SPACING-	2-0-0	CSI.	DEFL.	in (lc)	l/defl	L/d	PLATES	GRIP
TCLL 20.0	Plate Grip DOL	1.15	TC 0.28	Vert(LL)	-0.24 14-15	>999	360	MT20	244/190
TCDL 10.0	Lumber DOL	1.15	BC 0.56	Vert(CT)	-0.36 14-15	>999	240		
BCLL 0.0 *	Rep Stress Incr	YES	WB 0.48	Horz(CT)	0.11 10	n/a	n/a		
BCDL 10.0	Code IRC2015/TPI2014		Matrix-AS	Wind(LL)	0.10 17-53	>999	240		
								Weight: 469 lb	FT = 25%

LUMBER-
TOP CHORD 2x6 SP No.1
BOT CHORD 2x6 SP No.1
WEBS 2x4 SP No.2
OTHERS 2x4 SP No.2

BRACING-
TOP CHORD Structural wood sheathing directly applied, except
2-0-0 oc purlins (5-3-6 max.): 5-7.
BOT CHORD Rigid ceiling directly applied.
WEBS 1 Row at midpt 3-15, 6-15, 6-14, 9-14

MiTek recommends that Stabilizers and required cross bracing be installed during truss erection, in accordance with Stabilizer Installation guide.

REACTIONS. (lb/size) 2=1887/0-3-8 (min. 0-2-6), 10=1887/0-3-8 (min. 0-2-6)
Max Horz 2=-327(LC 10)
Max Uplift 2=-349(LC 12), 10=-349(LC 13)
Max Grav 2=2012(LC 2), 10=2012(LC 2)

FORCES. (lb) - Max. Comp./Max. Ten. - All forces 250 (lb) or less except when shown.
TOP CHORD 2-57=-3370/640, 3-57=-3302/673, 3-4=-2600/594, 4-5=-2483/641, 5-58=-2153/632,
6-58=-2153/632, 6-59=-2153/632, 7-59=-2153/632, 7-8=-2483/641, 8-9=-2600/594,
9-60=-3302/673, 10-60=-3370/640
BOT CHORD 2-61=-512/2978, 17-61=-512/2978, 17-62=-512/2978, 16-62=-512/2978, 15-16=-512/2978,
15-63=-227/2197, 63-64=-227/2197, 14-64=-227/2197, 13-14=-448/2852, 13-65=-448/2852,
12-65=-448/2852, 12-66=-448/2852, 10-66=-448/2852
WEBS 3-17=0/418, 3-15=-1022/406, 5-15=-109/900, 6-15=-313/276, 6-14=-313/275,
7-14=-109/900, 9-14=-1023/407, 9-12=0/418

- NOTES-**
- 1) Unbalanced roof live loads have been considered for this design.
 - 2) Wind: ASCE 7-10; Vult=130mph Vasd=103mph; TCDL=6.0psf; BCDL=6.0psf; h=15ft; Cat. II; Exp C; Enclosed; MWFRS (envelope) gable end zone and C-C Exterior(2) -0-9-5 to 3-9-14, Interior(1) 3-9-14 to 17-10-12, Exterior(2) 17-10-12 to 24-4-13, Interior(1) 24-4-13 to 28-1-4, Exterior(2) 28-1-4 to 34-7-5, Interior(1) 34-7-5 to 46-9-5 zone; C-C for members and forces & MWFRS for reactions shown; Lumber DOL=1.60 plate grip DOL=1.60
 - 3) Truss designed for wind loads in the plane of the truss only. For studs exposed to wind (normal to the face), see Standard Industry Gable End Details as applicable, or consult qualified building designer as per ANSI/TPI 1.
 - 4) Provide adequate drainage to prevent water ponding.
 - 5) All plates are 2x4 MT20 unless otherwise indicated.
 - 6) Gable studs spaced at 2-0-0 oc.
 - 7) This truss has been designed for a 10.0 psf bottom chord live load nonconcurrent with any other live loads.
 - 8) * This truss has been designed for a live load of 30.0psf on the bottom chord in all areas where a rectangle 3-6-0 tall by 2-0-0 wide will fit between the bottom chord and any other members, with BCDL = 10.0psf.

Job J1124-6098	Truss A1SGE	Truss Type GABLE	Qty 1	Ply 1	Southern Concrete
--------------------------	-----------------------	----------------------------	-----------------	-----------------	--------------------------

Comtech, Inc., Fayetteville, NC 28309, David Simonson

Run: 8.630 s Jul 12 2024 Print: 8.630 s Jul 12 2024 MiTek Industries, Inc. Mon Nov 11 10:59:02 2024 Page 2
 ID:Rv_0MPgYYr2mSaUtDo4oxyKIDO-Fu4_4c0jUe8vQZgDobZyKq0Jf7L54JKzIFBDBByKHwt

Job Reference (optional)

NOTES-

- 9) Provide mechanical connection (by others) of truss to bearing plate capable of withstanding 100 lb uplift at joint(s) except (jt=lb) 2=349, 10=349.
- 10) This truss is designed in accordance with the 2015 International Residential Code sections R502.11.1 and R802.10.2 and referenced standard ANSI/TPI 1.
- 11) This truss design requires that a minimum of 7/16" structural wood sheathing be applied directly to the top chord and 1/2" gypsum sheetrock be applied directly to the bottom chord.
- 12) Graphical purlin representation does not depict the size or the orientation of the purlin along the top and/or bottom chord.

LOAD CASE(S) Standard

Job J1124-6098	Truss B1	Truss Type COMMON	Qty 1	Ply 1	Southern Concrete
Comtech, Inc., Fayetteville, NC 28309, David Simonson					Job Reference (optional)

Run: 8.630 s Jul 12 2024 Print: 8.630 s Jul 12 2024 MiTek Industries, Inc. Mon Nov 11 10:59:02 2024 Page 1
ID:Rv_0MPgPYr2mSaUtDo4oxyKIDO-Fu4_4c0Jue8vQZgDobZyKq0Kr?NZ4NFzifBDBByKHwt

-0-10-8	7-10-6	15-0-0	22-1-10	30-0-0	30-10-8
0-10-8	7-10-6	7-1-10	7-1-10	7-10-6	0-10-8

Scale = 1:50.6

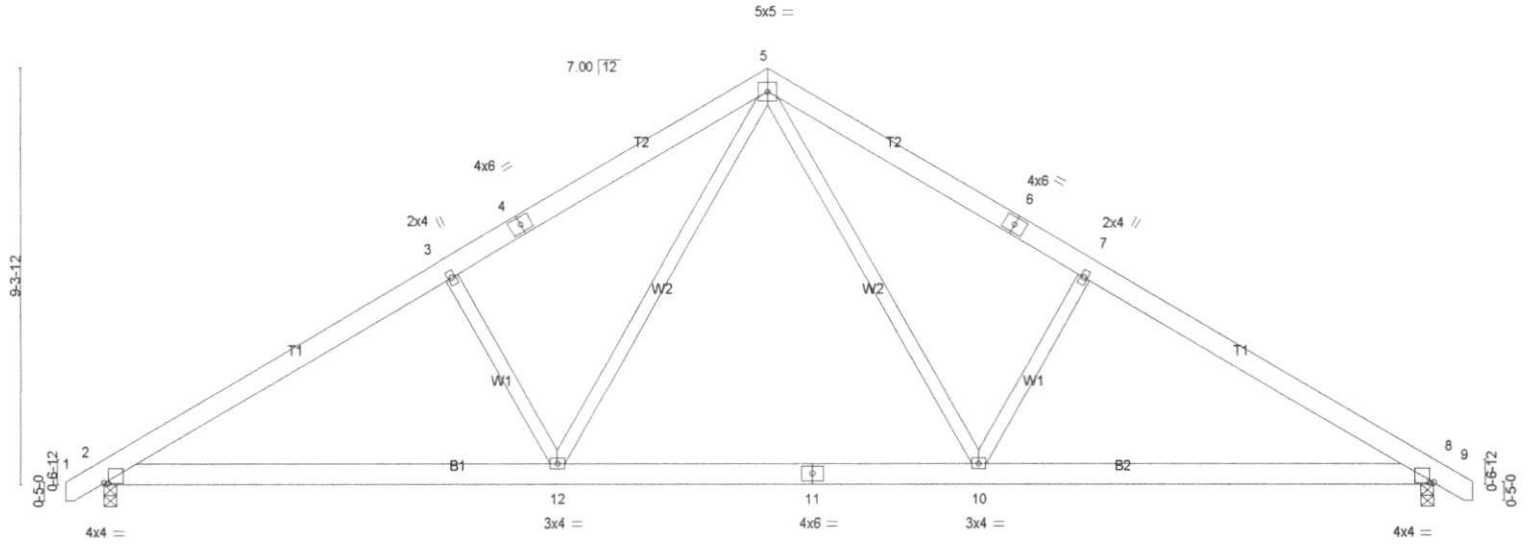

10-2-15	19-9-1	30-0-0
10-2-15	9-6-2	10-2-15
Plate Offsets (X,Y)-- [2:0-1-2,0-0-2], [8:0-1-2,0-0-2]		

LOADING (psf)	SPACING-	2-0-0	CSI.	DEFL.	in (loc)	l/defl	L/d	PLATES	GRIP
TCLL 20.0	Plate Grip DOL	1.15	TC 0.21	Vert(LL)	-0.15	10-12	>999	MT20	244/190
TCDL 10.0	Lumber DOL	1.15	BC 0.40	Vert(CT)	-0.21	10-12	>999		
BCLL 0.0 *	Rep Stress Incr	YES	WB 0.23	Horz(CT)	0.04	8	n/a		
BCDL 10.0	Code IRC2015/TPI2014		Matrix-AS	Wind(LL)	0.04	12-15	>999		
								Weight: 200 lb	FT = 25%

LUMBER-
TOP CHORD 2x6 SP No.1
BOT CHORD 2x6 SP No.1
WEBS 2x4 SP No.2

BRACING-
TOP CHORD Structural wood sheathing directly applied.
BOT CHORD Rigid ceiling directly applied.

MiTek recommends that Stabilizers and required cross bracing be installed during truss erection, in accordance with Stabilizer Installation guide.

REACTIONS. (lb/size) 2=1247/0-3-8 (min. 0-1-8), 8=1247/0-3-8 (min. 0-1-8)
Max Horz 2=-221(LC 10)
Max Uplift 2=-79(LC 12), 8=-79(LC 13)
Max Grav 2=1284(LC 19), 8=1284(LC 20)

FORCES. (lb) - Max. Comp./Max. Ten. - All forces 250 (lb) or less except when shown.
TOP CHORD 2-19=-1952/367, 3-19=-1897/392, 3-4=-1807/404, 4-20=-1735/417, 5-20=-1708/444,
5-21=-1708/444, 6-21=-1736/417, 6-7=-1807/404, 7-22=-1898/392, 8-22=-1953/367
BOT CHORD 2-12=-205/1779, 12-23=-25/1158, 11-23=-25/1158, 11-24=-25/1158, 10-24=-25/1158,
8-10=-213/1614
WEBS 5-10=-133/854, 7-10=-496/262, 5-12=-133/853, 3-12=-496/262

- NOTES-**
- Unbalanced roof live loads have been considered for this design.
 - Wind: ASCE 7-10; Vult=130mph Vasd=103mph; TCDL=6.0psf; BCDL=6.0psf; h=15ft; Cat. II; Exp C; Enclosed; MWFRS (envelope) and C-C Exterior(2) -0-9-5 to 3-7-8, Interior(1) 3-7-8 to 15-0-0, Exterior(2) 15-0-0 to 19-4-13, Interior(1) 19-4-13 to 30-9-5 zone; C-C for members and forces & MWFRS for reactions shown; Lumber DOL=1.60 plate grip DOL=1.60
 - This truss has been designed for a 10.0 psf bottom chord live load nonconcurrent with any other live loads.
 - * This truss has been designed for a live load of 30.0psf on the bottom chord in all areas where a rectangle 3-6-0 tall by 2-0-0 wide will fit between the bottom chord and any other members, with BCDL = 10.0psf.
 - Provide mechanical connection (by others) of truss to bearing plate capable of withstanding 100 lb uplift at joint(s) 2, 8.
 - This truss is designed in accordance with the 2015 International Residential Code sections R502.11.1 and R802.10.2 and referenced standard ANSI/TPI 1.
 - This truss design requires that a minimum of 7/16" structural wood sheathing be applied directly to the top chord and 1/2" gypsum sheetrock be applied directly to the bottom chord.

LOAD CASE(S) Standard

Job J1124-6098	Truss B1GE	Truss Type COMMON SUPPORTED GAB	Qty 1	Ply 1	Southern Concrete
--------------------------	----------------------	---	-----------------	-----------------	--------------------------

Comtech, Inc., Fayetteville, NC 28309, David Simonson

Run: 8.630 s Jul 12 2024 Print: 8.630 s Jul 12 2024 MiTek Industries, Inc. Mon Nov 11 10:59:03 2024 Page 1
ID:Rv_OMPgPYr2mSaUtDo4oxyKIDO-J4eNHy1LFxGm2jFQMI4Bs2YFFPpepr_7XJwnjeyKHws

-0-10-8	15-0-0	30-0-0	30-10-8
0-10-8	15-0-0	15-0-0	0-10-8

Scale = 1:50.7

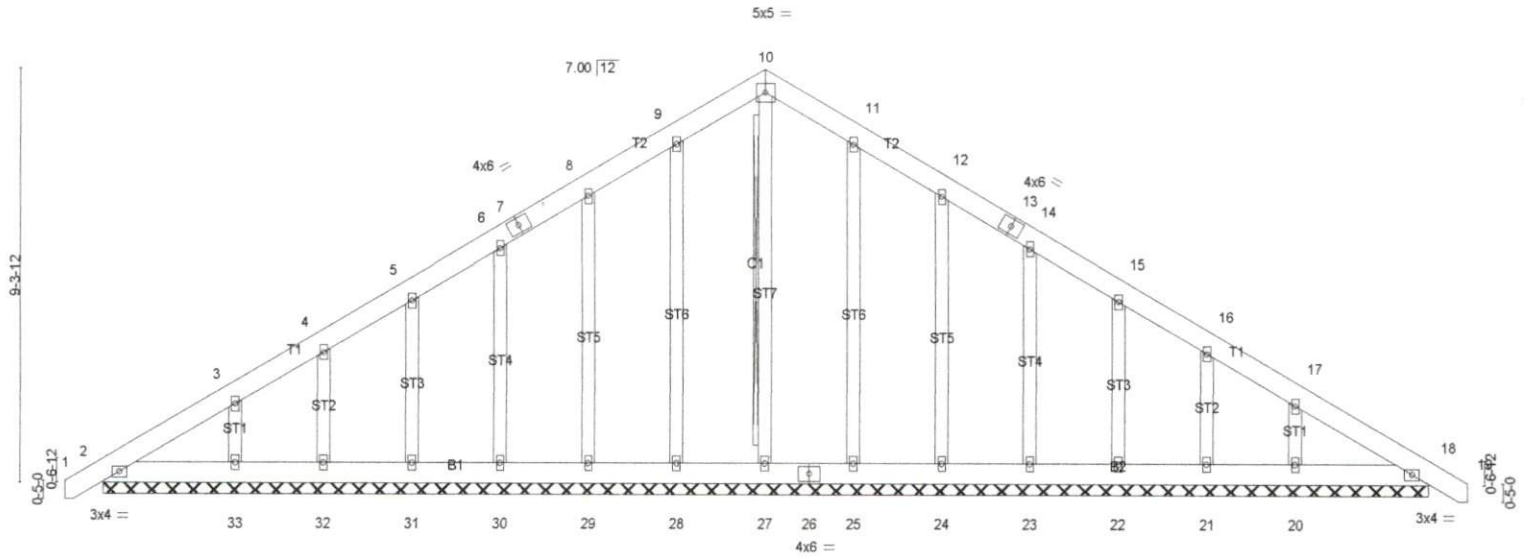

30-0-0
30-0-0

LOADING (psf)	SPACING- 2-0-0	CSI.	DEFL. in (loc) l/defl L/d	PLATES	GRIP
TCLL 20.0	Plate Grip DOL 1.15	TC 0.04	Vert(LL) 0.00 18 n/r 120	MT20	244/190
TCDL 10.0	Lumber DOL 1.15	BC 0.02	Vert(CT) 0.00 18 n/r 120		
BCLL 0.0 *	Rep Stress Incr YES	WB 0.14	Horz(CT) 0.01 18 n/a n/a		
BCDL 10.0	Code IRC2015/TPI2014	Matrix-S			
				Weight: 246 lb	FT = 25%

LUMBER-
TOP CHORD 2x6 SP No.1
BOT CHORD 2x6 SP No.1
OTHERS 2x4 SP No.2

BRACING-
TOP CHORD Structural wood sheathing directly applied or 6-0-0 oc purlins.
BOT CHORD Rigid ceiling directly applied or 10-0-0 oc bracing.
WEBS T-Brace: 2x4 SPF No.2 - 10-27
Fasten (2X) T and I braces to narrow edge of web with 10d (0.131"x3") nails, 6in o.c., with 3in minimum end distance.
Brace must cover 90% of web length.

MiTek recommends that Stabilizers and required cross bracing be installed during truss erection, in accordance with Stabilizer Installation guide.

REACTIONS. All bearings 30-0-0.
(lb) - Max Horz 2=276(LC 11)
Max Uplift All uplift 100 lb or less at joint(s) 2, 28, 29, 30, 31, 32, 25, 24, 23, 22, 21 except 33=-116(LC 12), 20=-115(LC 13)
Max Grav All reactions 250 lb or less at joint(s) 2, 27, 28, 29, 30, 31, 32, 25, 24, 23, 22, 21, 18 except 33=257(LC 19), 20=256(LC 20)

FORCES. (lb) - Max. Comp./Max. Ten. - All forces 250 (lb) or less except when shown.

- NOTES-**
- Unbalanced roof live loads have been considered for this design.
 - Wind: ASCE 7-10; Vult=130mph Vasd=103mph; TCCL=6.0psf; BCDL=6.0psf; h=15ft; Cat. II; Exp C; Enclosed; MWFRS (envelope) gable end zone and C-C Corner(3) -0-9-5 to 3-7-8, Exterior(2) 3-7-8 to 15-0-0, Corner(3) 15-0-0 to 19-4-13, Exterior(2) 19-4-13 to 30-9-5 zone; C-C for members and forces & MWFRS for reactions shown; Lumber DOL=1.60 plate grip DOL=1.60
 - Truss designed for wind loads in the plane of the truss only. For studs exposed to wind (normal to the face), see Standard Industry Gable End Details as applicable, or consult qualified building designer as per ANSI/TPI 1.
 - All plates are 2x4 MT20 unless otherwise indicated.
 - Gable requires continuous bottom chord bearing.
 - Gable studs spaced at 2-0-0 oc.
 - This truss has been designed for a 10.0 psf bottom chord live load nonconcurrent with any other live loads.
 - * This truss has been designed for a live load of 30.0psf on the bottom chord in all areas where a rectangle 3-6-0 tall by 2-0-0 wide will fit between the bottom chord and any other members.
 - Provide mechanical connection (by others) of truss to bearing plate capable of withstanding 100 lb uplift at joint(s) 2, 28, 29, 30, 31, 32, 25, 24, 23, 22, 21 except (jt=lb) 33=116, 20=115.
 - This truss is designed in accordance with the 2015 International Residential Code sections R502.11.1 and R802.10.2 and referenced standard ANSI/TPI 1.
 - Warning: Additional permanent and stability bracing for truss system (not part of this component design) is always required.

LOAD CASE(S) Standard

Job J1124-6098	Truss PBA	Truss Type Piggyback	Qty 29	Ply 1	Southern Concrete
--------------------------	---------------------	--------------------------------	------------------	-----------------	--------------------------

Comtech, Inc., Fayetteville, NC 28309, David Simonson Run: 8.630 s Jul 12 2024 Print: 8.630 s Jul 12 2024 MiTek Industries, Inc. Mon Nov 11 10:59:03 2024 Page 1 ID:Rv_OMPgPYr2mSaUtDo4oxyKIDO-j4eNHylLFxGm2FQMI4Bs2YV_Pnyptc7XJwnjeyKHws

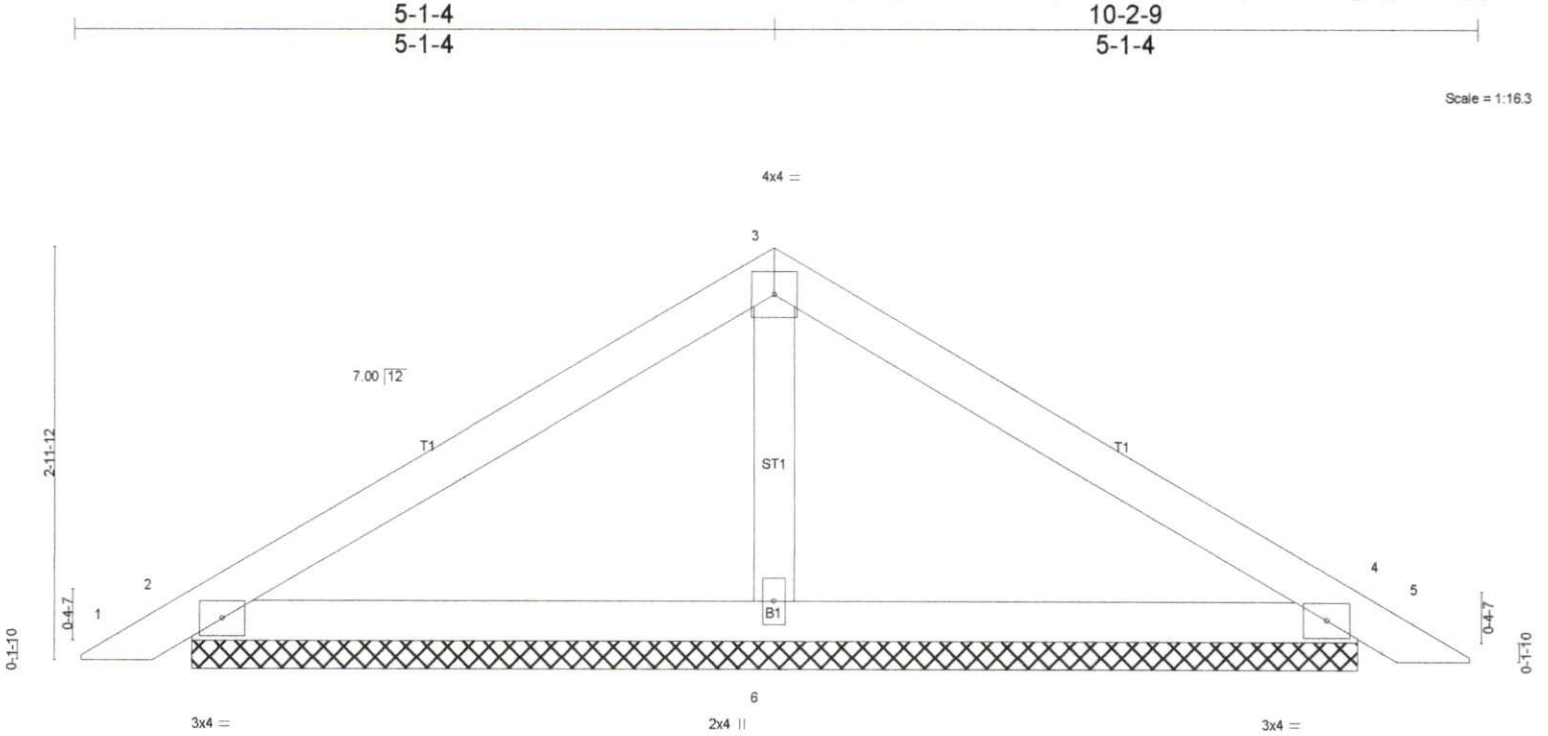

Scale = 1:16.3

LOADING (psf)		SPACING-		CSI.		DEFL.		PLATES		GRIP	
TCLL	20.0	2-0-0	Plate Grip DOL	1.15	TC	0.25	in (loc)	l/defl	L/d	MT20	244/190
TCDL	10.0	Lumber DOL	1.15	BC	0.13	Vert(LL)	0.01	5	n/r		
BCLL	0.0 *	Rep Stress Incr	YES	WB	0.03	Vert(CT)	0.02	5	n/r		
BCDL	10.0	Code IRC2015/TPI2014		Matrix-P		Horz(CT)	0.00	4	n/a		
										Weight: 33 lb	FT = 25%

LUMBER-	BRACING-
TOP CHORD 2x4 SP No.1	TOP CHORD Structural wood sheathing directly applied or 6-0-0 oc purlins.
BOT CHORD 2x4 SP No.1	BOT CHORD Rigid ceiling directly applied or 10-0-0 oc bracing.
OTHERS 2x4 SP No.2	

MiTek recommends that Stabilizers and required cross bracing be installed during truss erection, in accordance with Stabilizer Installation guide.

REACTIONS. (lb/size) 2=214/8-5-13 (min. 0-1-8), 4=214/8-5-13 (min. 0-1-8), 6=317/8-5-13 (min. 0-1-8)
 Max Horz 2=-67(LC 10)
 Max Uplift 2=-37(LC 12), 4=-44(LC 13)

FORCES. (lb) - Max. Comp./Max. Ten. - All forces 250 (lb) or less except when shown.

NOTES-

- Unbalanced roof live loads have been considered for this design.
- Wind: ASCE 7-10; Vult=130mph Vasd=103mph; TCDL=6.0psf; BCDL=6.0psf; h=15ft; Cat. II; Exp C; Enclosed; MWFRS (envelope) and C-C Exterior(2) 0-3-13 to 4-8-10, Interior(1) 4-8-10 to 5-1-4, Exterior(2) 5-1-4 to 9-4-3, Interior(1) 9-4-3 to 9-10-12 zone; C-C for members and forces & MWFRS for reactions shown; Lumber DOL=1.60 plate grip DOL=1.60
- Gable requires continuous bottom chord bearing.
- This truss has been designed for a 10.0 psf bottom chord live load nonconcurrent with any other live loads.
- * This truss has been designed for a live load of 30.0psf on the bottom chord in all areas where a rectangle 3-6-0 tall by 2-0-0 wide will fit between the bottom chord and any other members.
- Provide mechanical connection (by others) of truss to bearing plate capable of withstanding 100 lb uplift at joint(s) 2, 4.
- This truss is designed in accordance with the 2015 International Residential Code sections R502.11.1 and R802.10.2 and referenced standard ANSI/TPI 1.
- See Standard Industry Piggyback Truss Connection Detail for Connection to base truss as applicable, or consult qualified building designer.

LOAD CASE(S) Standard

Job J1124-6098	Truss PBASGE	Truss Type GABLE	Qty 2	Ply 1	Southern Concrete
--------------------------	------------------------	----------------------------	-----------------	-----------------	--------------------------

Comtech, Inc., Fayetteville, NC 28309, David Simonson

Run: 8.630 s Jul 12 2024 Print: 8.630 s Jul 12 2024 MiTek Industries, Inc. Mon Nov 11 10:59:04 2024 Page 1
ID:Rv_OMPgPYr2mSaUtDo4oxyKIDO-BGCIUI2z0FOdgtqcw0bRPF5gip9WYKLGzgf4yKHwr

Job Reference (optional)

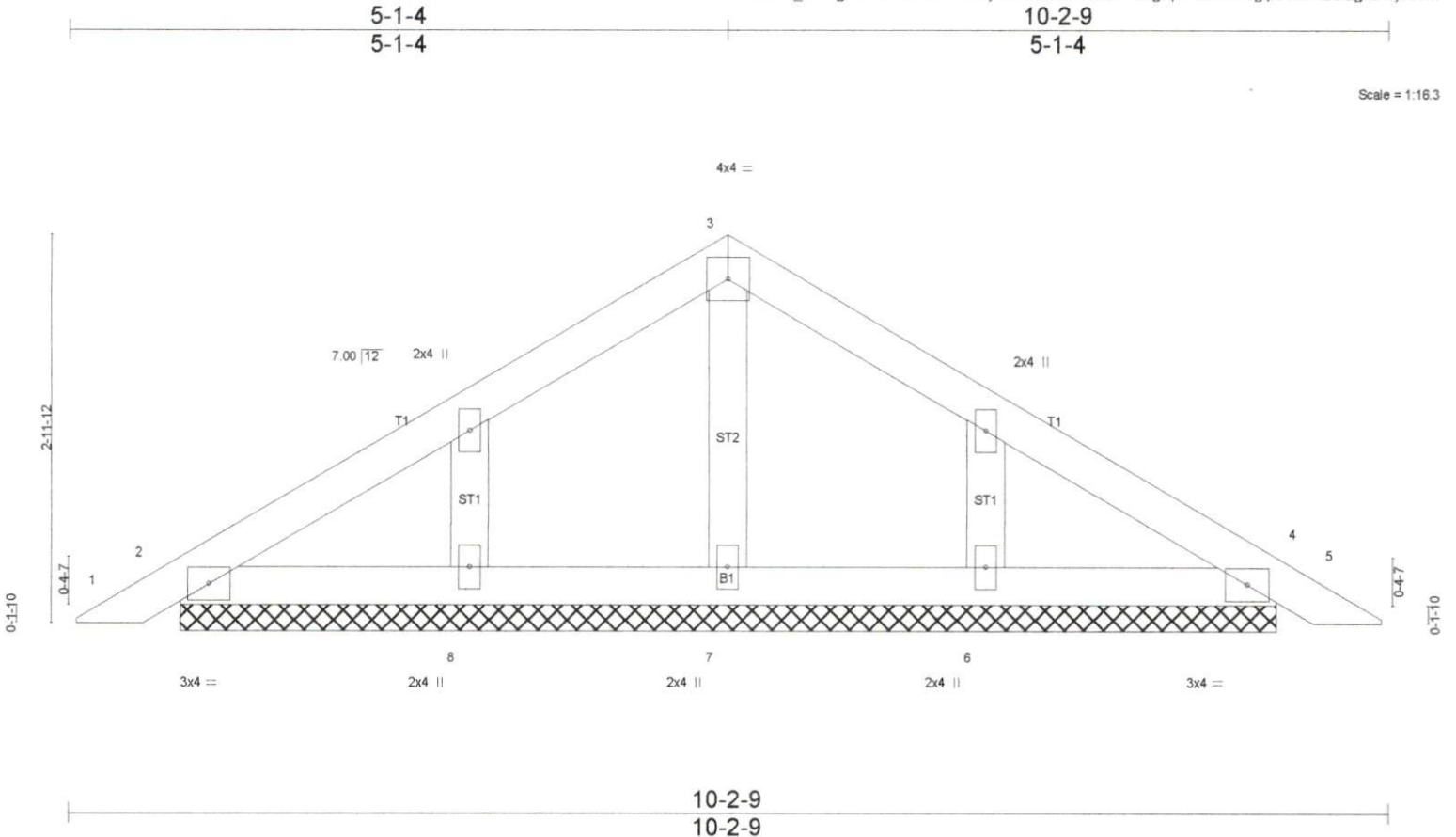

Scale = 1:16.3

LOADING (psf)	SPACING-	CSI.	DEFL.	PLATES	GRIP
TCLL 20.0	2-0-0	TC 0.25	in (loc) l/defl L/d	MT20	244/190
TCDL 10.0	Plate Grip DOL 1.15	BC 0.05	Vert(LL) 0.01 5 n/r 120		
BCLL 0.0 *	Lumber DOL 1.15	WB 0.00	Vert(CT) 0.02 5 n/r 120		
BCDL 10.0	Rep Stress Incr YES	Matrix-P	Horz(CT) 0.00 4 n/a n/a		
	Code IRC2015/TPI2014			Weight: 37 lb	FT = 25%

LUMBER-
TOP CHORD 2x4 SP No.1
BOT CHORD 2x4 SP No.1
OTHERS 2x4 SP No.2

BRACING-
TOP CHORD Structural wood sheathing directly applied or 6-0-0 oc purlins.
BOT CHORD Rigid ceiling directly applied or 10-0-0 oc bracing.

MiTek recommends that Stabilizers and required cross bracing be installed during truss erection, in accordance with Stabilizer Installation guide.

REACTIONS. All bearings 8-5-13.
(lb) - Max Horz 2=-84(LC 10)
Max Uplift All uplift 100 lb or less at joint(s) except 2=-124(LC 12), 4=-124(LC 13)
Max Grav All reactions 250 lb or less at joint(s) 7, 8, 6 except 2=305(LC 1), 4=305(LC 1)

FORCES. (lb) - Max. Comp./Max. Ten. - All forces 250 (lb) or less except when shown.
TOP CHORD 2-11=-298/159, 4-12=-298/159

NOTES-

- Unbalanced roof live loads have been considered for this design.
- Wind: ASCE 7-10; Vult=130mph Vasd=103mph; TCDL=6.0psf; BCDL=6.0psf; h=15ft; Cat. II; Exp C; Enclosed; MWFRS (envelope) gable end zone and C-C Exterior(2) 0-3-13 to 4-8-10, Interior(1) 4-8-10 to 5-1-4, Exterior(2) 5-1-4 to 9-4-3, Interior(1) 9-4-3 to 9-10-12 zone; C-C for members and forces & MWFRS for reactions shown; Lumber DOL=1.60 plate grip DOL=1.60
- Truss designed for wind loads in the plane of the truss only. For studs exposed to wind (normal to the face), see Standard Industry Gable End Details as applicable, or consult qualified building designer as per ANSI/TPI 1.
- Gable requires continuous bottom chord bearing.
- Gable studs spaced at 2-0-0 oc.
- This truss has been designed for a 10.0 psf bottom chord live load nonconcurrent with any other live loads.
- * This truss has been designed for a live load of 30.0psf on the bottom chord in all areas where a rectangle 3-6-0 tall by 2-0-0 wide will fit between the bottom chord and any other members.
- Provide mechanical connection (by others) of truss to bearing plate capable of withstanding 124 lb uplift at joint 2 and 124 lb uplift at joint 4.
- This truss is designed in accordance with the 2015 International Residential Code sections R502.11.1 and R802.10.2 and referenced standard ANSI/TPI 1.
- See Standard Industry Piggyback Truss Connection Detail for Connection to base truss as applicable, or consult qualified building designer.

LOAD CASE(S) Standard



**ROOF & FLOOR
TRUSSES & BEAMS**

Reilly Road Industrial Park
Fayetteville, N.C. 28309
Phone: (910) 864-8787
Fax: (910) 864-4444

Drawings reference this Plan or report to 1989F are shown for compliance with the manufacturer's Code requirements. The contractor shall refer to the attached Tables (extracted from the manufacturer's Code requirements) to determine the minimum foundation size and number of steel studs required to support reactions greater than 2000R but not greater than 1500R. A registered design professional shall be retained to design the support system for any reaction that exceeds those specified in the attached Tables. A registered design professional shall be retained to design the support system for all reactions that exceed 1500R.

Signature: *Bob Lewis*
Bob Lewis

LOAD CHART FOR JACK STUDS

(BASED ON TABLES 607 TO 610)
NUMBER OF JACK STUDS REQUIRED IS A FND OF 14.484/12000

TRUSS REACTION (KIP)	NO. OF JACKS PER TRUSS	TRUSS REACTION (KIP)	NO. OF JACKS PER TRUSS
1700	1	2550	1
3400	2	5100	2
5100	3	7650	3
6800	4	10200	4
8500	5	12750	5
10200	6	15300	6
11900	7		
13600	8		
15300	9		

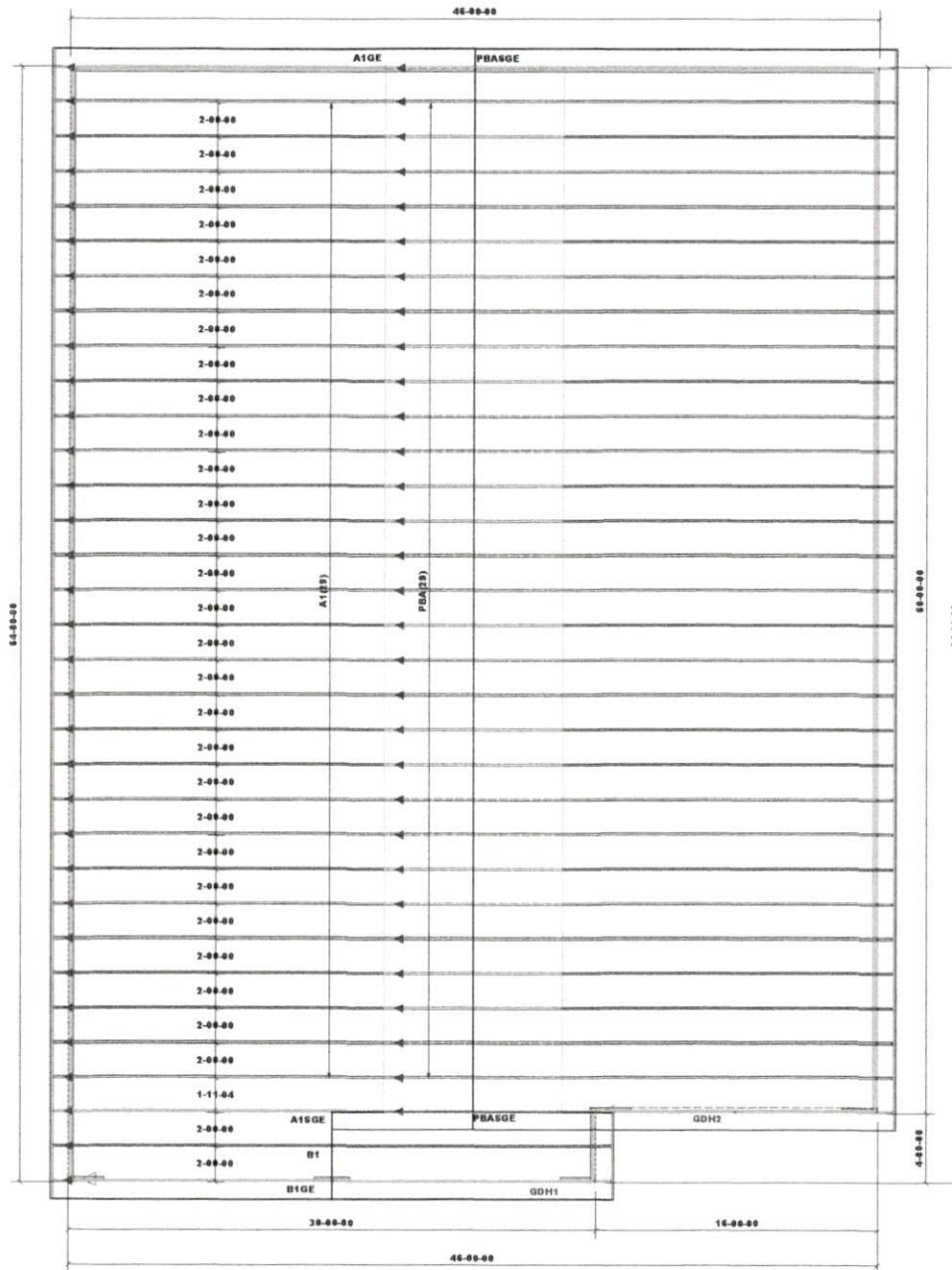

Roof Area = 3612.04 sq.ft.
Ridge Line = 67 ft.
Hip Line = 0 ft.
Horiz. OH = 133 ft.
Raked OH = 129.66 ft.
Decking = 124 sheets

LVL not Sized by Comtech

PlotID	Length	Product	Pieces	Net Qty	Fab Type
GDH1	30-00-00	1-3/4"x 11-7/8" LVL Kerto-5	2	2	FF
GDH2	17-00-00	1-3/4"x 11-7/8" LVL Kerto-5	2	2	FF

Truss Placement Plan
SCALE: NTS

▲ Indicates Left End of Truss
(Reference Engineered Truss Drawing)
Do NOT Erect Truss Backwards

BUILDER	CITY / CO.	Site Address - City / Hoike
Cash - Southern Concrete	ADDRESS	Site Address
JOB NAME	MODEL	Roof
PLAN	DATE REV.	11/11/24
SEAL DATE	DRAWN BY	Bob Lewis
QUOTE #	SALES REP.	Bob Lewis
JOB #		J1124-6098

THIS IS A TRUSS PLACEMENT DRAWING ONLY. These trusses are designed as individual building components to be incorporated into the building design of the specifier of the building design. The individual design shows the truss design identified on the placement drawing. The building designer is responsible for temporary and permanent bracing of the roof and floor system and for the overall structure. The design of the truss support structure including foundations, beams, walls, and columns is the responsibility of the building designer. For general guidance regarding bracing, consult ICC-ES and ECSI. It is provided with the truss delivery package or online @ site.trusstry.com