



7/9/2024

Tarheel Basement Systems
3333 Air Park Rd.,
Fuquay Varina, NC, 27526

RE: Foundation Repair for 101 North 12th St., Erwin, NC 28339

Existing structure is a wood framed building with a crawlspace foundation. Based on an assessment provided by Tarheel Basement Systems (TBS), the structure is experiencing settlement that is greater than what is expected for the age of the structure. TBS has recommended Intellijacks to stabilize the main support beam. Scapular Engineering has reviewed the data provided by TBS and has verified that the proposed products are adequate per the manufacturer’s requirements for the loads applied.

Attachment contents

Page 1..... Foundation Plan
Page 2-3..... Product Details
Page 4-7..... Product Specifications

This report and other work by Scapular Engineering Firm and Engineer of Record (“EOR”) were performed pursuant to a contract with TBS and are intended for its use only. This report, and related information if any, to you is not intended to create a relationship between the property owner and Scapular Engineering Firm or EOR, contractual or otherwise, and is not intended to create any duties, guarantees, or warranties (express or implied) to property owner by Scapular Engineering Firm or EOR. This report relies upon, and is dependent upon, the accuracy of information provided by TBS and the analysis in this report is limited to the information provided. This report is limited to the products themselves and only address the structural issue as diagnosed and presented by TBS. Scapular Engineering Firm did not diagnose the structure and is not responsible for a misdiagnose provided by TBS.

Jacob John Bullinger
PE: 056953
Scapular Engineering Firm
Licensee Number: P-2995
23576 State Route J
St. Mary, MO 63673
(573) 275-7647



7/9/2024

Foundation Plan

Intellijack Notes:

1. Intellijack shall be installed per manufacturer's specifications, reference attached details.
2. Spacing of Intellijack shall be as indicated on plan U.N.O.
3. Height of Intellijack shall not exceed 10 feet.
4. Intellijack and Intellibeam shall be used for supplemental supports only and only used for additional support to the current structure.
5. Existing post and/or beam shall not be removed or modified in any way. If Intellijack is used to lift, the existing posts shall be shimmed to ensure the beam bears fully on all existing posts/supports.
6. A. Option A: Intellijacks to be placed between existing posts that are unchanged to bear on a 2'x2'x2' thick concrete footing over a 12" thick minimum compacted aggregate base, or an 18"x18"x18" minimum compacted aggregate base with the 'IJ-IC' Precast Concrete Footing placed underneath the Intellijack, or the IJ-AB Aluminum Base.
B. Option B: Existing posts to be replaced with Intellijacks in the same location as existing posts to bear on existing footings or on a new concrete footing that matches existing concrete footing size and meets a minimum footing size of 2'x2'x2' thick concrete footing over a 12" thick minimum compacted aggregate base, or an 18"x18"x18" minimum compacted aggregate base with the 'IJ-IC' Precast Concrete Footing placed underneath the Intellijack, or the IJ-AB Aluminum Base.
7. Concrete shall have a minimum 28 day compressive strength of 3,000 PSI and rebar shall be #4 bars at 6" O.C., EW and grade 60.
8. If Intellijacks are supporting existing beams, contractor shall verify that the existing beam is of acceptable condition. If existing beam is damaged or shows signs of deterioration, beam shall be replaced with like-kind materials.

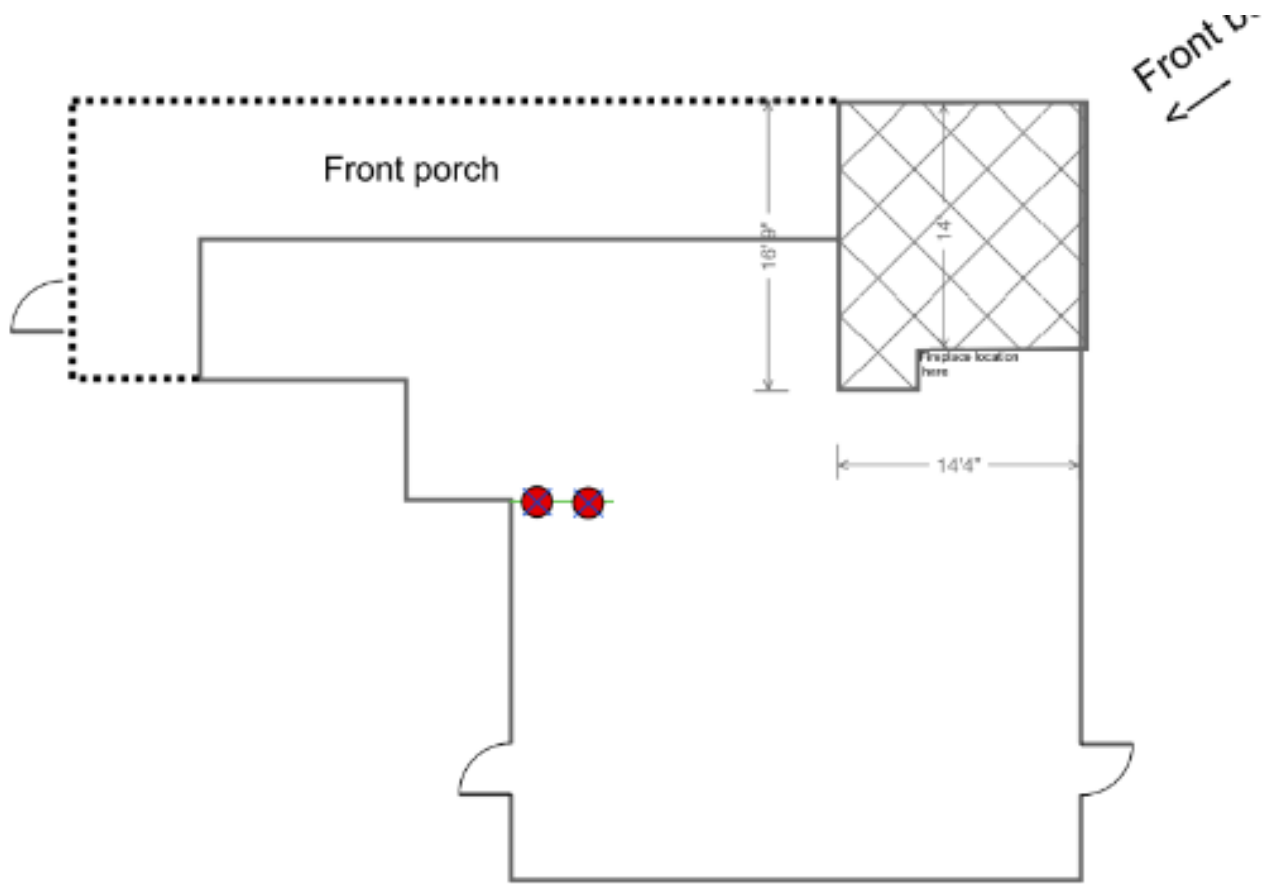

2 Intellijacks will be used.

Product Detail

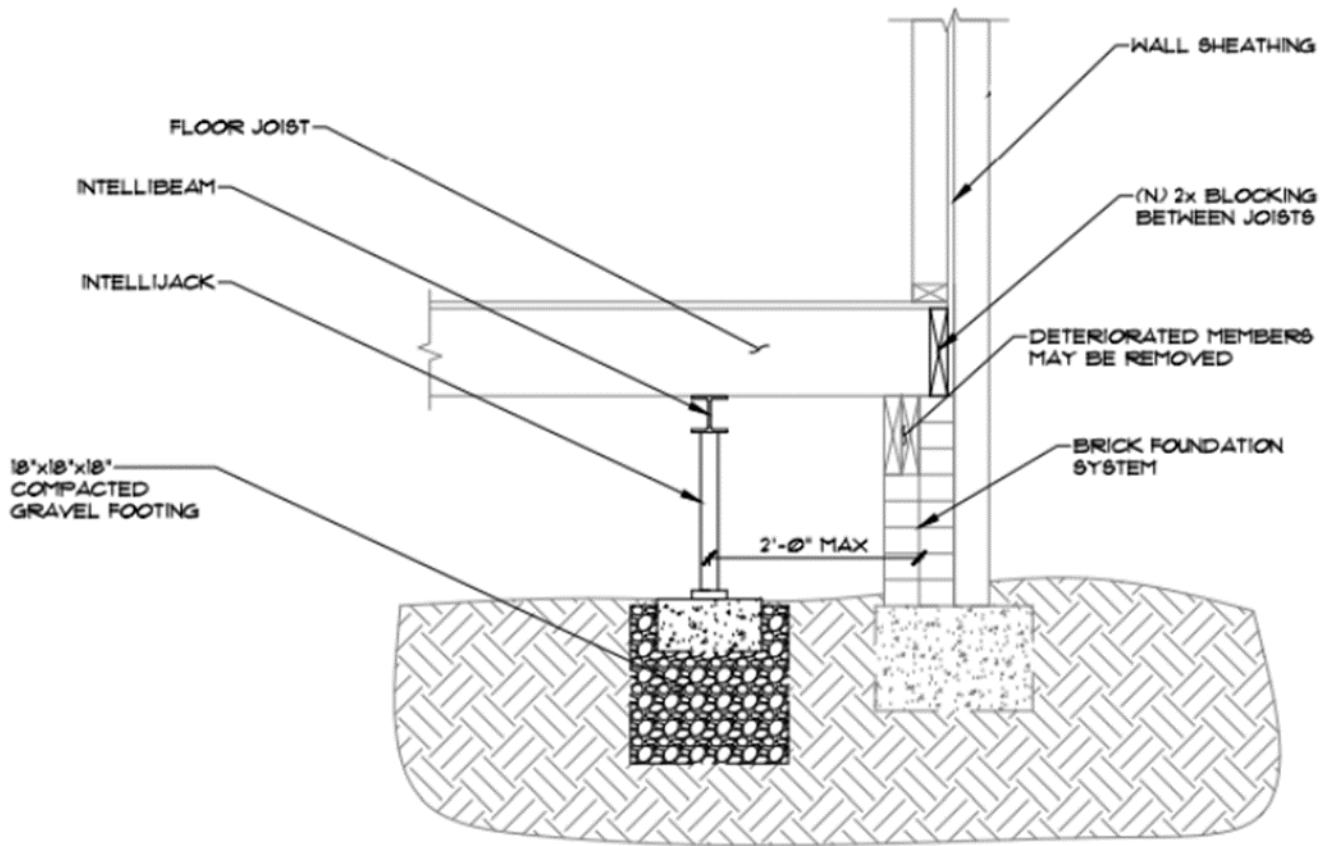

Crawl Space and Basement Detail

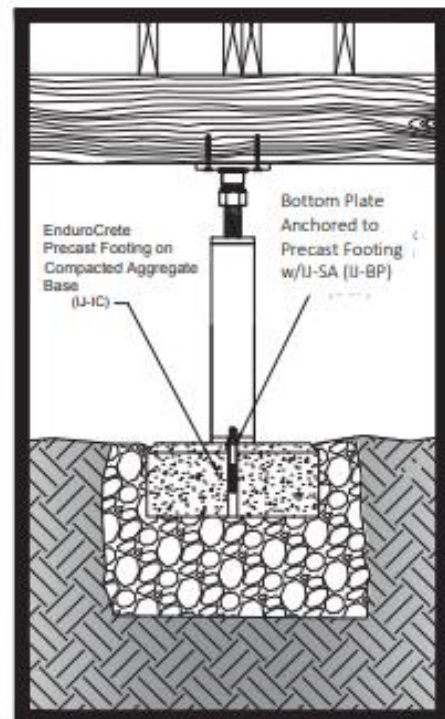
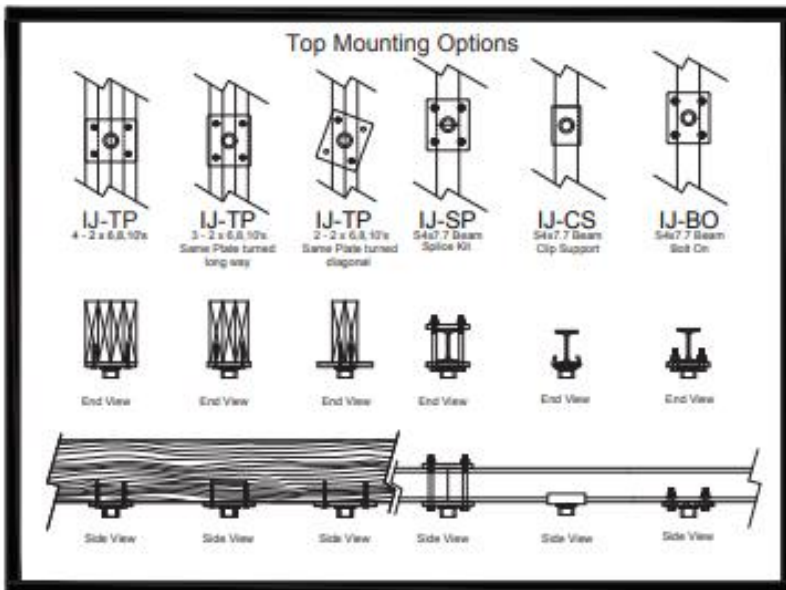
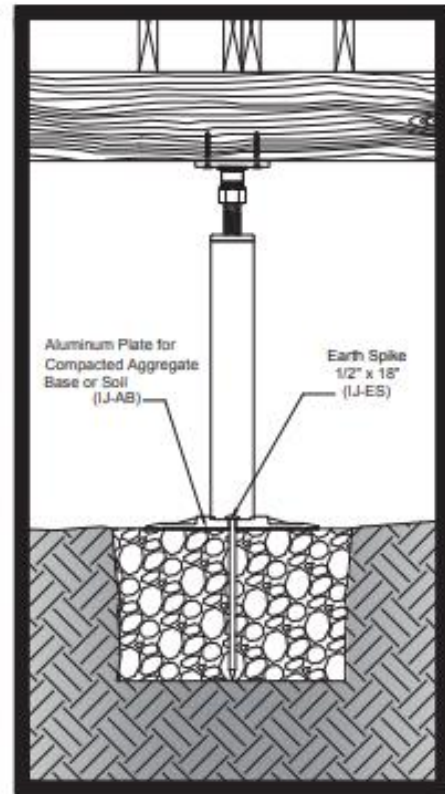
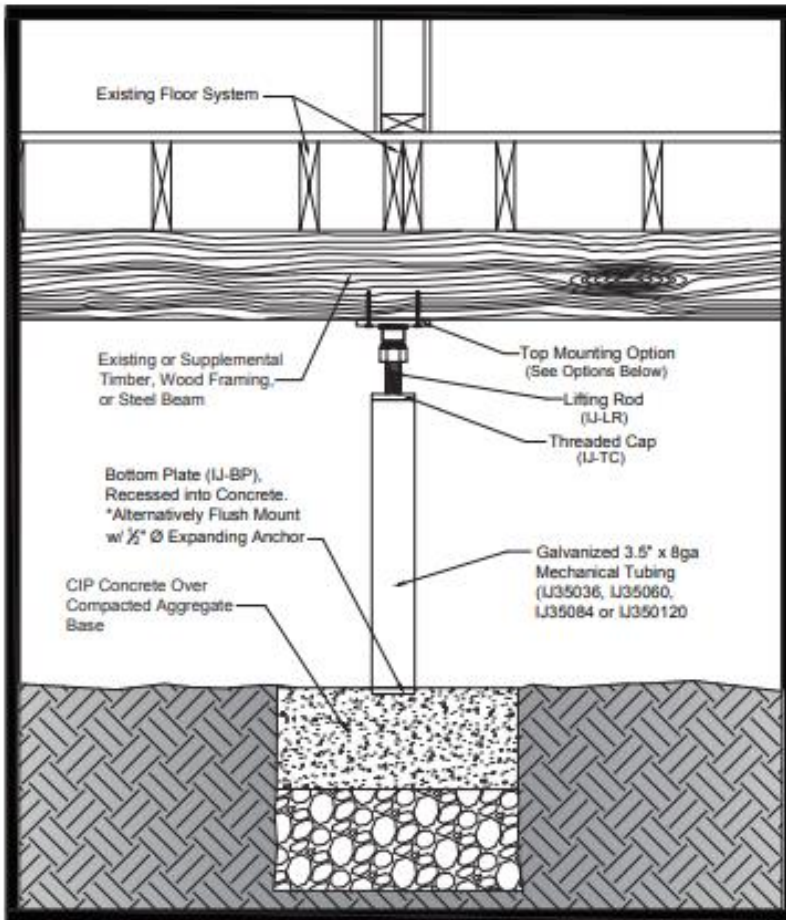

IntelliJack™

Product Specifications

IMG INDEPENDENCE
MATERIALS
GROUP

IntelliJack Load Capacity

The allowable load carrying capacity for the IntelliJack is shown the PEI Code Evaluation Report, PER-19250. Allowable downward compressive load varies with column height but is established at 20.7 kips at an assembled height of 10 feet. Refer to the Evaluation Report for higher load values allowed at shorter column lengths. Allowable capacity for the IntelliJack system is likely to be governed by the footing design and available allowable soil pressure.

Installation for Permanent Applications

For applications where the construction is to be permanent, the threads of the lifting rod (IJ-LR) shall be damaged with a cold chisel after adjustment to the desired length. One screw thread immediately above the threaded cap shall be damaged for at least half its depth, and for a length of 1.5 inches to prevent loosening of the rod. Upward adjustment will still be feasible.

IJ-TP (Top Plate)

1/2" THK x 5" x 6" long, ASTM A36 hrp&o plate with four 0.313" holes at corners and one 1.75" OD x 0.25" thick wall x 1.25" long retaining ring centered on plate with 0.25" external fillet weld, all around.

Clear Zinc Electroplated to ASTM B633 Type III

IJ-35036, IJ-35060, IJ-35084, IJ-350120 (Mechanical Tubing)

3.50" OD x 0.165" thick wall ASTM A500, Grade C mechanical tubing, available 36", 60", 84" and 120" long and may be field cut to desired length.

Yield strength = 46 ksi (min)

Tensile strength = 62 ksi (min)

Galvanized to ASTM A1057.

IJ-SP (Splice Plate)

Upper and lower 1/2" THK x 5" x 6" long ASTM A36 hrp&o plates with four 0.563" holes at corners with welded retaining ring on lower plate with same detail as IJ-TP. Plates are bolted with 4- 1/2" x 5.5" SAE Grade 5 bolts and nuts, sandwiching the S4x7.7 steel beam. Center of splices must align with center of support, below.

Clear Zinc Electroplated to ASTM B633 Type III

IJ-BO (Bolt On Beam Mount)

1- 1/2" THK x 5" x 6" long ASTM A36 hrp&o plate with four 0.563" holes at corners with welded retaining ring on lplate with same detail as IJ-TP. Plates bolted with 4- 1/2" x 5.5" SAE Grade 5 bolts and nuts, through the bottom flange of the S4x7.7 steel beam

Clear Zinc Electroplated to ASTM B633 Type III

IJ-BP (Bottom Plate)

1/2" THK x 3.5" x 3.5" long ASTM A36 hrp&o Plate with one 0.563" hole centered on plate, and one 3.13" OD x 0.188" thick wall x 1" long ASTM A513 ring, internally welded to plate.

Clear Zinc Electroplated to ASTM B633 Type III

IJ-PB (Precast Base)

Commercially available, precast concrete post base with 3,000 psi (min) compressive strength, and 12" x 12" base footprint.

IJ-ES (Earth Spike)

5/8" x 18" long ASTM A615 G40 pointed reinforcing rod stake with welded nut.

Yield strength = 40,000 psi(min)

Tensile strength = 60,000 PEI(min)

IJ-LR (Lifting Rod)

1.25" diameter x 10" long ASTM F1554-GR55 S1 threaded rod with tack welded heavy hex nut

Yield strength = 55 ksi (min)

Tensile strength = 75 ksi (min)

Clear Zinc Electroplated to ASTM B633 Type III

IJ-TC (Threaded Cap)

3.50" OD x 1.00" thick solid ASTM A108-13 (1018) disk CNC machined with 1.25"-7 threads and recessed shoulder to fit the inside diameter of the mechanical tubing.

Yield strength = 50 ksi (min)

Tensile strength = 68 ksi (min).

Clear Zinc Electroplated to ASTM B633 Type III

IJ-CS (Clip Support)

1/4" THK x 3.30" x 1.25" x 4.50" long, ASTM A36 hro&p plate with ends shaped to receive insertion of S4x7.7 beam flange, and 1.75" OD x 0.25" thick wall x 1.25" long retaining ring centered on plate with 0.25" external fillet weld, all around. Clear Zinc Electroplated to ASTM B633 Type III

S4x7.7 Supplemental Steel Beam

4.00" Tall X 2.63" wide, steel S shape (I-beam), ASTM A992, available 120" and 144" long, and may be field cut to desired length.

Yield Strength = 50 ksi (min)

Tensile strength = 65 ksi (min)

IJ-AB (Aluminum Base)

1" thick, at the hub, x 14.2" diameter AA 356.0-T5 cast aluminum base plate.

Yield strength = 20 ksi (min)

Tensile strength = 25 ksi (min)

IJ-IC (Precast Concrete Footing)

6" THK x 14" diameter, 5,000 psi (min), fiber reinforced, precast concrete footing with a 0.75" diameter hole at center, and ¼" chamfer at upper circumference.

PEI Evaluation Service® is an accredited ISO Standard 17065 Product Certifier, accredited by the IAS. This **Product Evaluation Report** represents a product that PEI ES has Evaluated. This product has a Product Evaluation Service Agreement & Follow-up Inspection Service Agreement. This **Product Evaluation Report** in no way implies warranty for this product or relieves Independence Materials Group, LLC of their liabilities for this product. This **PER** is an official document if it is within one year of the Initial or Re-Approval date.

Initial Approval
October, 2019

Re-Approved
October, 2020

See all PEI ES reports at: www.p-e-i.com

Report Owner

Independence Materials Group, LLC (IMG)
1741 Corporate Landing Parkway
Virginia Beach, VA 23454

Approved Manufacturing Location

Independence Materials Group (IMG)
634 Rosewood Drive, Door 7
Columbia, SC 29201

Product

IntelliJack Support Columns

Evaluation Report Information

www.independencematerialsgroup.com
IMG contact: Allen Gantt - (803) 807-8629

General Details

The following described support columns are evaluated for vertical compression load only. The support columns are intended for interior use in wood frame or light steel frame construction. These columns have a rust-inhibitive coating.

Product Description

The IntelliJack columns are a steel tube column with a loose bottom plate at one end and an adjustable screw at the other end. The columns are constructed of a Steel Tube, a Collar, Threaded Rod and two nuts. These columns have a 5" adjustability using the threaded rod with a damaged thread to limit travel.

Component Description

Steel Tube - 3-1/2" outside diameter by .165" thick made from ASTM A500 Steel, Grade B-C, $F_y \geq 50\text{ksi}$, $F_u \geq 55\text{ksi}$. and galvanized to ASTM A1057.

Collar (threaded cap) - The collar is placed in one end of the steel tube. A threaded hole is in the center of the collar for the threaded rod. The collar is made from ASTM A1018 steel and zinc electroplated to meet ASTM B633, Type III.

Threaded Rod - The threaded rod is 1.25"-7 x 10" long. The threaded rod is made from ASTM F1554 Grade 55 Steel and is zinc electroplated to meet ASTM B633, Type III.

Nut - 1.25"-7 Heavy Hex nut, ASTM A563 Grade A with a zinc coating. One nut is welded to the threaded rod and one is used as a jam nut against collar.

Bottom Plate - The bottom plate is an assembly made from a 3-1/2" x 3-1/2" x 1/2" thick plate made from ASTM A36 steel and a 3/4" long piece of 3" outside diameter tube welded to the plate and is clear zinc electroplated to meet ASTM B633, Type III.

Top Plate - The top plate is an assembly made from a 6" x 5" x 1/2" thick plate made from ASTM A36 steel, with a 1-1/4" long piece of 1-3/4" outside diameter tube welded to the plate and is clear zinc electroplated to meet ASTM B633, Type III.

Code Compliance

IntelliJack Support Columns	
2012 International Residential Code Section R407.2 and R407.3	2012 International Building Code Section 104.11 and 2205.1
2015 International Residential Code Section R407.2 and R407.3	2015 International Building Code Section 104.11, 2205.1 and 2205.2
2018 International Residential Code Section R407.2 and R407.3	2018 International Building Code Section 104.11, 2205.1 and 2205.2

Compliance with the following Standard

- AISC-360-10** - Specification for Structural Steel Buildings-Allowable Stress Design
- AISC-360-16** - Specification for Structural Steel Buildings-Allowable Stress Design
- ICC-ES AC335** - Acceptance Criteria for Adjustable Steel Columns

General Product Use

1. All columns shall be installed vertically plumb with either end up and bear on a footing capable of carrying the imposed load. The base and top of the column must be restrained to prevent lateral movement except where exempt by the Building Code.
2. These columns are intended for vertical compression load only. They have not been evaluated for any other load direction or type.
3. For applications where the construction is to be permanent, the threads of the lifting rod shall be damaged with a cold chisel after adjustment to the desired length. One screw thread immediately above the threaded cap shall be damaged for at least half its depth and for a length of 1-1/2" to prevent loosening of the rod.
4. The **IMG IntelliJack** nominal size is the support column at its shortest adjustment and must not be adjusted to a longer length by more than 5".
5. The bearing capacity of the top and bottom plates and their attachment to load carrying members are outside of the scope of this evaluation report.
6. If the basement slab is poured around the IntelliJack, a corrosive resistant coating must be applied to the parts of the IntelliJack that will be in contact with concrete.

Items Requiring Verification

The following items are related to the use of **IMG IntelliJack** support columns, but not within the scope of this evaluation specification. However these items are related to the determination of code compliance.

1. Design, calculations, and details for the building system verifying compliance with this report.
2. Connections of the columns to the footing and supported structure.
3. Footing design and calculations for supporting the columns and the imposed load.
4. The bearing capacity of the beam/member supported.

Table 1
Load Rating for IntelliJack Columns

Nominal Size	3-1/2" O.D.	
	Allowable Load for ASD (lbs.)	Design Strength for LRFD (lbs.)
12"	24,860	39,780
96"	24,860	39,780
108"	24,100	36,220
120"	20,700	31,110

Notes:

1. All steel tube to be ASTM A500 $F_y \geq 50\text{ksi}$, $F_u \geq 55\text{ksi}$
2. Nominal size is the column at it's shortest adjustment
3. Designed per AISC-360-16 - ASD
4. LRFD Design Strength must be compared to factored loads

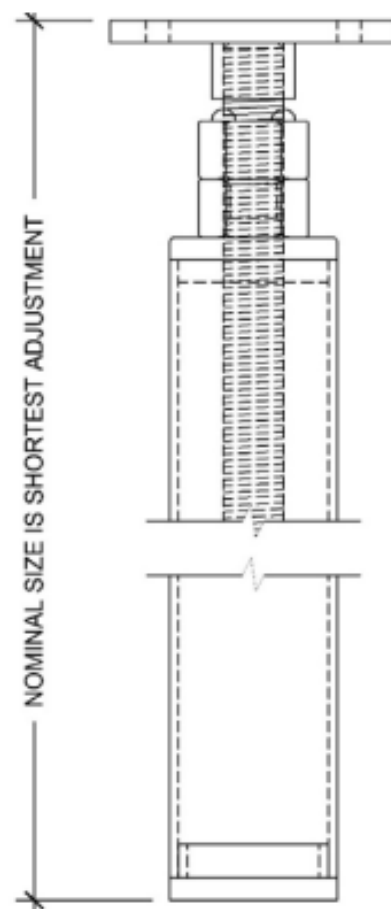

Figure 1 - IntelliJack Column

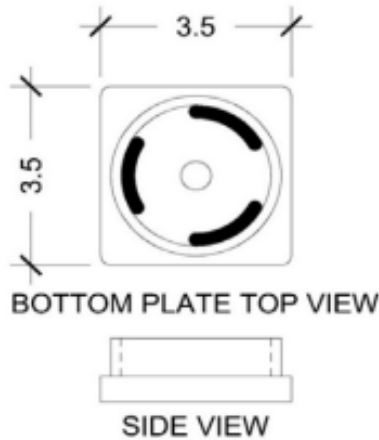

Figure 2 - Bottom Plate

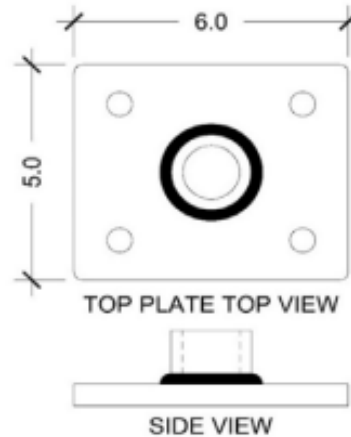

Figure 3 - Top Plate

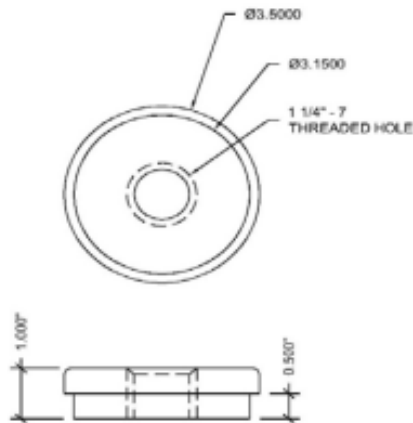

Figure 4 - Collar

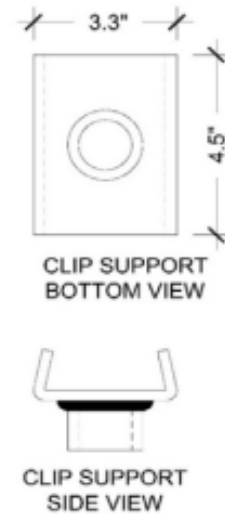

Figure 5 - Clip Support

Product Labeling

All columns manufactured by **Independence Materials Group** that are covered by this **PER** must have a label attached with at least the following information:

1. Manufacturer Name
2. Load Capacity of Column
3. This **PER** Number & **Pei ES** Logo
4. On Adjustable Column Labels, the Minimum and Maximum Column Length

Acceptable Evaluation Marks



Product Documentation

- A Product Evaluation Service Agreement between **Pei Evaluation Service®** and **Independence Materials Group, LLC**
- An Follow-up Inspection Service Agreement between **Progressive Engineering Inc.** and **Independence Materials Group, LLC**
- A **Independence Materials group, LLC** - IntelliJack support columns Quality Control Manual - Dated: 9/23/2020
- A **Independence Materials Group, LLC** - IntelliJack support columns Components Drawings - Dated: September, 2015
- Pei** Calculations No. 2019-3169 - IMG - Column Calculations - Dated: 6/18/2019 - stamped by a Professional Engineer
- Pei** Calculations No. 2019-3169 - IMG - Adjustment Screw Calculation - Dated: 11/1/2019 - stamped by a Professional Engineer
- Pei** Calculations No. 2020-0214 - IMG - IntelliJack Eccentric Loaded Axial Capacity - Dated: 1/23/2020 - stamped by a Professional Engineer
- Pei** Test Report 2019-6392 - Dated: 12/19/2019 - stamped by a Professional Engineer