



March 7, 2024

Mr. Shane Phelps
NC Dept. of Insurance
Manufactured Building Division
1202 Mail Service Center
Raleigh, NC 27699-1202
(919) 661 – 5880

Re: Nationwide Custom Homes
Model 196763-NC

Mr. Phelps:

Enclosed please find one (1) copy of each of the above-mentioned projects for your review. These projects have been reviewed by NTA and found to be in compliance with the North Carolina State requirements.

Should you have any questions or comments, please contact me at your earliest convenience.

Sincerely,

Kip Whitehead

Kip Whitehead
Account Manager
ICC-NTA LLC

DESIGN INFORMATION

USE GROUP	R-3
CONSTRUCTION	TYPE VB
FLOOR LOAD(S)	40/10 1st
ROOF LOAD	30/10
GROUND SNOW LOAD	20 (ATTIC LIVE LOAD: 20 LBS.)
WIND LOAD (FOR UNIT DESIGN)	150 mph Vult / 116 mph Vasd ⁽¹⁾⁽²⁾⁽³⁾⁽⁴⁾
SEISMIC DESIGN	C
EXPOSURE	C
CLIMATE ZONE	3a
MAXIMUM DESIGNED MEAN ROOF HEIGHT	18'-0"

<p>FOOTNOTES:</p> <ul style="list-style-type: none"> • IF 115Vult/89Vasd MPH STRUCTURE MUST BE LOCATED AT AN ELEVATION OF LESS THAN 2,700 FEET IN MOUNTAIN REGIONS. • IF 120Vult/93Vasd MPH STRUCTURE MUST BE LOCATED AT AN ELEVATION OF 2,700 TO LESS THAN 3,000 FEET IN MOUNTAIN REGIONS. • IF 130Vult/101Vasd MPH STRUCTURE MUST BE LOCATED AT AN ELEVATION OF 3,000 TO LESS THAN 3,500 FEET IN MOUNTAIN REGIONS. • IF 140Vult/108Vasd MPH STRUCTURE MUST BE LOCATED AT AN ELEVATION OF 3,500 TO LESS THAN 4,500 FEET IN MOUNTAIN REGIONS. • 150Vult/116Vasd MPH STRUCTURE MUST BE LOCATED AT AN ELEVATION OF 4,500 FEET OR GREATER IN MOUNTAIN REGIONS. 	<p>NOTICE:</p> <p>IT IS THE RESPONSIBILITY OF THE PURCHASER TO INSURE THAT THE ATTACHED PLANS CONFORM TO LOCAL ORDINANCES IN RESPECT TO BUILDING SIZE, HEIGHT, SETBACKS, OR AESTHETICS WHICH ARE ENFORCED BY THE LOCAL JURISDICTION</p>
---	--

WIND BORNE DEBRIS AREA'S: HURRICANE SHUTTERS (IF REQUIRED) SHALL BE SUPPLIED AND SITE INSTALLED BY THE PURCHASER.

NOTICE:
PLANS ARE EXTRACTED FROM APPROVED SYSTEMS DOCUMENTATION AND CAN NOT BE MODIFIED OUTSIDE THE PARAMETERS SET FORTH. ANY CHANGES TO PLANS MUST BE APPROVED BY NATIONWIDE HOMES ENGINEERING DEPARTMENT. ANY MINOR CHANGES OR MODIFICATIONS ARE SUBJECT TO THIRD PARTY INSPECTION.

**** PHYSICAL ADDRESS: CLARA "C" MODEL HOME ****

CODE CONFORMANCE

NORTH CAROLINA

- NC RESIDENTIAL CODE, 2018 EDITION
- NC ENERGY CODE, 2018 EDITION
- 2017 NC ELECTRICAL CODE

ATTENTION LOCAL INSPECTION DEPARTMENT

IF THIS STRUCTURE IS IN A THERMAL ZONE THAT IS MORE STRINGENT THAN THAT LISTED ON THESE PLANS, IS SET ON PILINGS, OR IS INSTALLED AT A MOUNTAIN REGION OR COASTAL HIGH HAZARD SITE SUCH THAT WIND OR OTHER DESIGN PARAMETERS ARE INCREASED, THE DESIGN MUST BE DETERMINED TO BE ADEQUATE FOR THE ACTUAL SITE CONDITIONS. ALTERATIONS MAY THEN BE REQUIRED TO BRING THE HOME INTO COMPLIANCE WITH THE MORE STRINGENT CONDITIONS.

ATTENTION THIS NOTE APPLIED IF UPPER LEVEL IS COMPLETELY FINISHED

* BEFORE A CERTIFICATE OF OCCUPANCY CAN BE ISSUED FOR CAPE MODEL DESIGNS, THE UPPER LEVEL MUST BE FINISHED AND ALL COMPLETION OF THE UPPER LEVEL IS SUBJECT TO SITE INSPECTION WITH APPROVAL BY THE LOCAL JURISDICTION.
* (EXCEPTION: UPPER LEVELS LABELED AS UNFINISHED AND/OR STORAGE ONLY)
*
*
*

- PLANS MAY BE MASTERED
- PLANS MAY BE REVERSED

SEE QC MANUAL PAGE 3.79
FOR CRANE LIFTING POINTS

CERTIFICATION INFORMATION

<p>REFER TO "NOTE-1" ON FLOOR PLAN: CERTIFICATION INFORMATION LOCATED UNDER THE KITCHEN SINK: A) DATA PLATE B) 3rd PARTY INSPECTION LABEL C) STATE LABEL D) INSULATION CERTIFICATION (NC)</p>	<p>REFER TO "NOTE-2" ON FLOOR PLAN: CERTIFICATION INFORMATION LOCATED IN ADJACENT SECTIONS ON CLOSET WALL A) 3rd PARTY INSPECTION LABEL</p>
---	---

TYPICAL FOUNDATION NOTES

FOOTING NOTES:

1. FOOTINGS BASED ON 2,000psf SOIL BEARING CAPACITY. IF SOIL BEARING CAPACITY IS LOWER, FOOTINGS MUST BE REVISED AS DETERMINED BY REQUIREMENTS OF AUTHORITY HAVING JURISDICTION.
2. BOTTOM OF ALL FOOTINGS TO BE BELOW FROST LINE AS DETERMINED BY LOCAL BUILDING CODES
3. CONCRETE TO DEVELOP A MINIMUM 28 DAY COMPRESSIVE STRENGTH OF 3000 PSI

TYPICAL TERRACE NOTES:

1. EXTERIOR CONCRETE TO BE AIR ENTRAINED WITH A MIN. 28 DAY COMPRESSIVE STRENGTH OF 3000 PSI (OR LOCAL REQUIREMENT)
2. 4" CONC. OVER 6"x6" #8 WIRE MESH.
3. OFFSET CAP TO CARRY SLAB.
4. INSTALL METAL FLASHING BETWEEN CONC. & WOOD MEMBERS.
5. TERRACES TO BE CONSTRUCTED AFTER HOUSE IS SET ON FOUNDATION.
6. PURCHASER RESPONSIBLE FOR ACCESSIBILITY INTO LIVING UNIT PER STATE & LOCAL CODE.

OPTIONAL BASEMENT NOTES:

1. ALL BASEMENT DOORS & WINDOWS ARE SUPPLIED & INSTALLED BY PURCHASER.
2. DOOR & WINDOW SIZE & LOCATION SUBJECT TO CHANGE ACCORDING TO SITE CONDITIONS.
3. BACKFILL TO BE IN & TAMPED PRIOR TO ARRIVAL OF HOUSE.
4. FOUNDATION DRAINAGE & DAMP-PROOFING TO CONFORM TO CURRENT BUILDING CODE.
5. ALL ELECTRICAL, PLUMBING & MECHANICAL INSTALLATION WITHIN THE BASEMENT ARE THE RESPONSIBILITY OF THE PURCHASER & SUBJECT TO APPROVAL & INSPECTION BY THE LOCAL JURISDICTION.

UNIT FASTENING REQUIREMENTS:

AREAS W/ WIND ZONE 150 mph Vult / 116 mph Vasd (3-SEC. GUST):

1. PURCHASER RESPONSIBLE TO SUPPLY & INSTALL ALL FOUNDATION TO UNIT, PILING TO UNIT & UNIT TO UNIT WITH TIE DOWN STRAPS.
2. COMPLETION OF ROOF COMPONENT TIE DOWN PER "HIGH WIND CONST." DETAILS IS THE RESPONSIBILITY OF THE PURCHASER.
3. PURCHASER RESPONSIBLE FOR ALL PILING TYPE FOUNDATION CONST. DESIGN & ENGINEERING & SUBJECT TO APPROVAL & INSPECTION BY LOCAL JURISDICTION.



GENERAL FOUNDATION NOTES:

1. PURCHASER TO USE MORTAR TYPE "S" OR "M" FOR FOUNDATION CONSTRUCTION AS REQUIRED BY STATE & LOCAL CODES.
2. GROUND SURFACE WITHIN CRAWLSPACE AREAS TO BE COVERED WITH APPROVED VAPOR BARRIER TO ALLOW 1/1500 VENT REDUCTION AS CALCULATED. VENTS MUST BE LOCATED WITHIN 3'-0" OF EACH CORNER.
3. ALL FOUNDATION PLANS ARE SUGGESTIVE ONLY & MUST BE CONST. IN ACCORDANCE WITH STATE & LOCAL CODE REQUIREMENTS.
4. FOUNDATION DESIGNED FOR PROJECT SPECIFIC WIND ZONE. (3-SEC. GUST) (SEE FLOOR PLAN FOR EXACT WIND SPEED)

BRICK CASED DIMENSION NOTES: (IMPORTANT)

1. AN ALLOWANCE OF 5" MUST BE INCORPORATED TO EACH SIDE OF THE FOUNDATION DIMENSIONS IF BRICK CASED EXTERIOR IS SELECTED. NOTE THAT LIVING UNIT SIZES ARE NOT ADJUSTED. VERIFY DIMENSIONS W/ NATIONWIDE ENGINEERING DEPARTMENT OF CLARIFICATION OF DIMENSIONS ARE NEEDED PRIOR TO CONSTRUCTION.

TYPICAL PLUMBING NOTES

- ALL SUPPLY, DRAIN, WASTE & VENT LINES TO BE SUPPORTED AT 4'-0" O.C.
- PURCHASER TO SUPPLY & INSTALL ALL DWV & SUPPLY LINE MATERIALS FOR SITE COMPLETION OF PLUMBING CONNECTIONS UNDER FLOOR & BETWEEN TWO STORY STACK-ON SECTIONS. CONNECTIONS TO BE MADE AT WALL ACCESS ON TWO STORIES AS NOTED ON THE FLOOR PLAN WITH ALL CONNECTIONS SUBJECT TO INSPECTION BY LOCAL JURISDICTION.
- ALL VENTS SHALL TERMINATE MINIMUM 12" ABOVE THE ROOF.
- ALL FITTINGS, DRAIN WASTE, & VENT PIPES SHALL BE PVC/DWV PIPE W/ SOLVENT WELDED JOINTS PER THE MANUFACTURER INSTALLATION INSTRUCTIONS.
- ALL PLUMBING (ON 1ST LEVEL) WILL BE FACTORY INSTALLED TO BOTTOM OF FLOOR JOISTS. PURCHASER RESPONSIBLE FOR PLUMBING COMPLETION TO CONFORM TO CURRENT PLUMBING CODE.
- ALL CLEAN OUTS BY PURCHASER PER CURRENT PLUMBING CODE.
- ALL PVC/DWV TO CONFORM TO CURRENT PLUMBING CODE.
- ANTI-SCALD FAUCETS INSTALLED ON ALL SHOWER FAUCETS.
- PURCHASER RESPONSIBLE FOR FIRE-STOPPING ALL FLOOR CUTOUTS AT TUB TRAPS.
- HEATED WATER TO BATHTUBS/WHIRLPOOL TUBS LIMITED TO 120 DEGREES F. BY WATER TEMPERATURE LIMITING DEVICE CONFORMING TO CURRENT BUILDING CODE.
- SHOWER AND TUB/SHOWER COMBINATION VALVES SHALL BE EQUIPPED WITH CONTROL VALVES OF THE PRESSURE-BALANCE, THERMOSTATIC-MIXING OR COMBINATION PRESSURE-BALANCE/THERMOSTATIC-MIXING VALVE TYPES WITH A HIGH LIMIT STOP IN ACCORDANCE WITH ASSE 1016/ASME A112.1016/CSA B125.16. THE HIGH LIMIT STOP SHALL BE SET TO LIMIT THE WATER TEMPERATURE TO NOT GREATER THAN 120F.
- TEMPERATURE-ACTUATED MIXING VALVES, WHICH ARE INSTALLED TO REDUCE WATER TEMPERATURES TO DEFINED LIMITS, SHALL COMPLY WITH ASSE 1017. SUCH VALVES SHALL BE INSTALLED AT THE HOT WATER SOURCE.
- TEMPERATURE-ACTUATED, FLOW-REDUCTION DEVICES, WHERE INSTALLED FOR INDIVIDUAL FIXTURE FITTINGS, SHALL CONFORM TO ASSE 1062. SUCH VALVES SHALL NOT BE USED AS A SUBSTITUTE FOR THE BALANCED PRESSURE, THERMOSTATIC OR COMBINATION SHOWER VALVES REQUIRED FOR SHOWERS IN SECTION P2708.4.
- NOTES FOR WATER HAMMER ARRESTORS - "WATER HAMMER ARRESTORS CONFORMING TO ASSE 1010 AND INSTALLED PER MANUFACTURERS INSTRUCTIONS" AND "NOT REQUIRED FOR PLASTIC WATER DISTRIBUTION PIPE"
- A MEANS FOR CONTROLLING INCREASED PRESSURE CAUSED BY THERMAL EXPANSION SHALL BE INSTALLED WHERE REQUIRED IN ACCORDANCE WITH THE FOLLOWING:
- FOR WATER SERVICE SYSTEM SIZES UP TO AND INCLUDING 2 INCHES (51 MM), A DEVICE FOR CONTROLLING PRESSURE SHALL BE INSTALLED WHERE, BECAUSE OF THERMAL EXPANSION, THE PRESSURE ON THE DOWNSTREAM SIDE OF A PRESSURE-REDUCING VALVE EXCEEDS THE PRESSURE-REDUCING VALVE SETTING.
- WHERE A BACKFLOW PREVENTION DEVICE, CHECK VALVE OR OTHER DEVICE IS INSTALLED ON A WATER SUPPLY SYSTEM USING STORAGE WATER HEATING EQUIPMENT SUCH THAT THERMAL EXPANSION CAUSES AN INCREASE IN PRESSURE, A DEVICE FOR CONTROLLING PRESSURE SHALL BE INSTALLED.

1100 RIVES ROAD, MARTINSVILLE, VA 24112
(276) 632-7100
WWW.NATIONWIDECUSTOMHOMES.COM

© COPYRIGHT 2024 NATIONWIDE HOMES
ALL RIGHTS RESERVED



HOME PLANS AND GENERAL NOTES

1. THIS UNIT MUST BE CONNECTED TO A PUBLIC WATER SUPPLY & SEWER SYSTEM IF AVAILABLE
2. ONLY ONE HOUSE MAY BE BUILT UTILIZING THE PLANS DESIGNED FOR THIS CONTRACT JOB.

ATTENTION LOCAL INSPECTION DEPARTMENT

SET-UP INSTRUCTIONS FOR THIS MODULAR UNIT ARE INCLUDED WITHIN THESE PLANS.

- THE FOLLOWING ITEMS HAVE NOT BEEN COMPLETED BY NATIONWIDE HOMES, HAVE NOT BEEN INSPECTED BY NTA Inc. CODE COMPLIANCE MUST BE DETERMINED AT THE LOCAL LEVEL;
- FOUNDATION (INCLUDING FOOTING, WALLS, PIERS, COLUMNS, DRAINAGE)
 - INSTALLATION AND CONNECTION OF WELL AND PUMP OR CONNECTION TO PUBLIC WATER SYSTEM
 - INSTALLATION AND CONNECTION OF SEPTIC SYSTEM OR CONNECTION TO PUBLIC SEWER SYSTEM
 - INSTALLATION AND CONNECTION OF ELECTRICAL METER AND METER BASE WITH CONNECTION OF ELECTRICAL POWER FROM PUBLIC UTILITIES.
 - CONSTRUCTION OF STOOPS, PORCHES, STEPS, WALKS, DRIVEWAYS AND ALL SITE BUILT ATTACHMENTS.
 - COMPLETE FINAL GRADE AND LANDSCAPING, INCLUDING PLANTING & SEEDING.
 - CARPET SHIPPED PRE-WRAPPED, LABELED BY ROOM FOR BUILDING INSTALLATION.
 - HEATING/COOLING SYSTEM SUPPLIED AND SITE INSTALLED BY PURCHASER.
 - BASED ON STYLE OF HOUSE, ON-SITE CONNECTIONS AND/OR COMPLETING AS PRESCRIBED BY THE BUILDER OPERATIONS MANUAL.
 - IF WATER HEATER IS SHIPPED OR OMITTED, PURCHASER IS RESPONSIBLE FOR INSTALLATION TO FACTORY INSTALLED SUPPLY LINES & SITE CONNECTION TO ELECTRICAL SUPPLY.
 - IF AN OPTIONAL GAS FIREPLACE IS FACTORY INSTALLED IN MODULAR UNITS, CONNECTION OF A GAS SUPPLY LINE TO THE INSTALLED FIREPLACE
 - DRYER VENTED TO OUTSIDE AIR BY PURCHASER PER SECTION M1502 OF N.C.R.C.
 - IF BASEMENT FOUNDATION, BASEMENT STAIRS SUPPLIED & SITE CONST. BY PURCHASER.
 - 10-kVA ASSUMED FOR THE HVAC SYSTEM FOR SERVICE PANEL SIZING.
 - IT SHALL BE THE RESPONSIBILITY OF THE PURCHASER TO INSURE ANY SITE COMPLETION OF AN UNFINISHED AREA TO MEET LIGHT/VENTILATION, EGRESS, PLUMBING AND ELECTRICAL REQUIREMENTS AND SUBJECT TO INSPECTION BY LOCAL AND/OR STATE JURISDICTION.
 - ANY UNUSED CONDUITS OR PIPING ARE TO BE SEALED AT EACH END ON SITE BY OTHERS AND IS THE RESPONSIBILITY OF THE PURCHASER, AND IS SUBJECT TO INSPECTION AND APPROVAL BY THE LOCAL JURISDICTION.
 - WATER HEATER DRAIN PAN DRAIN SHALL EXTEND TO THE EXTERIOR OF THE BUILDING AND TERMINATE NOT LESS THAN 6" AND NOT MORE THAN 24" ABOVE ADJACENT GROUND SURFACE PER SECTION P2801.6.2 OF THE 2018 NCR
 - COMMUNICATIONS OUTLET SUPPLIED & INSTALLED BY PURCHASER AS REQUIRED BY CURRENT NEC, CHAPTER 8
 - ANY FACT. INST. SYSTEMS THAT ARE COMPLETED ON-SITE SHALL BE TESTED AS A WHOLE IN ACCORDANCE WITH 2018 NCR

RODENT PROOFING

- OPENINGS AND/OR PENETRATIONS AROUND ALL DRAIN PIPES, WATER SUPPLY LINES, AND ELECTRICAL WIRES AND CONDUITS, SHALL BE SEALED IN FACTORY WITH AN APPROVED METAL COLLAR OR OTHER APPROVED MATERIALS THAT ADHERE TO THE ADJOINING STRUCTURE.
- AT ALL TUB AND SHOWER P-TRAP CUTOUTS OR ACCESSSES, IT SHALL BE THE RESPONSIBILITY OF THE PURCHASER TO INSURE THAT THE OPENING/ACCESS IS SEALED ON SITE BY A FABRICATED WOOD PANEL, SECURED TO BLOCKING, AND SEALED TO INSURE NO RODENT PENETRATION CAN OCCUR INTO THE HOME.

REQUIREMENT FOR INTERIOR FINISHES		FLOOR, WALL, & ROOF SHEATHING		VAPOR BARRIER																																												
<p style="text-align: center;">FLAME SPREAD</p> <ul style="list-style-type: none"> - MAXIMUM FLAME SPREAD RATING FOR WALL AND CEILING FINISHES SHALL NOT EXCEED 200 - MAXIMUM FLAME SPREAD RATING FOR INSULATION SHALL NOT EXCEED 25 		<p style="text-align: center;">TYPE</p> <p style="text-align: center;">SPAN RATING</p> <table border="1" style="width: 100%; border-collapse: collapse;"> <tr> <th>LOCATION</th> <th>TYPE</th> <th>SPAN RATING</th> </tr> <tr> <td rowspan="2">FLOOR</td> <td>- 19/32" T&G OSB</td> <td>40/20</td> </tr> <tr> <td>- 23/32" T&G OSB</td> <td>48/24</td> </tr> <tr> <td rowspan="3">WALL</td> <td>- 7/16" SE OSB</td> <td>24/16</td> </tr> <tr> <td>- 19/32" SE OSB</td> <td>40/20</td> </tr> <tr> <td>- 7/16" ZIP PANEL</td> <td>24/16</td> </tr> <tr> <td>ROOF</td> <td>- 7/16" SE OSB</td> <td>24/16</td> </tr> <tr> <td></td> <td>- 7/16" SE OSB (EACH SHEET MINIMUM DIMENSION)</td> <td>24/16</td> </tr> </table>		LOCATION	TYPE	SPAN RATING	FLOOR	- 19/32" T&G OSB	40/20	- 23/32" T&G OSB	48/24	WALL	- 7/16" SE OSB	24/16	- 19/32" SE OSB	40/20	- 7/16" ZIP PANEL	24/16	ROOF	- 7/16" SE OSB	24/16		- 7/16" SE OSB (EACH SHEET MINIMUM DIMENSION)	24/16	<table border="1" style="width: 100%; border-collapse: collapse;"> <tr> <th>LOCATION</th> <th>R-VALUE</th> <th>PAPER</th> </tr> <tr> <td rowspan="2">FLOOR</td> <td>R-30</td> <td>IDENT-FACED</td> </tr> <tr> <td>R-30</td> <td>IDENT-FACED</td> </tr> <tr> <td rowspan="4">WALL</td> <td>R-13</td> <td>IDENT-FACED</td> </tr> <tr> <td>R-15</td> <td>IDENT-FACED</td> </tr> <tr> <td>R-19</td> <td>IDENT-FACED</td> </tr> <tr> <td>R-21</td> <td>IDENT-FACED</td> </tr> <tr> <td rowspan="2">ROOF</td> <td>R-30</td> <td>IDENT-FACED</td> </tr> <tr> <td>R-38</td> <td>IDENT-FACED</td> </tr> </table>		LOCATION	R-VALUE	PAPER	FLOOR	R-30	IDENT-FACED	R-30	IDENT-FACED	WALL	R-13	IDENT-FACED	R-15	IDENT-FACED	R-19	IDENT-FACED	R-21	IDENT-FACED	ROOF	R-30	IDENT-FACED	R-38	IDENT-FACED
LOCATION	TYPE	SPAN RATING																																														
FLOOR	- 19/32" T&G OSB	40/20																																														
	- 23/32" T&G OSB	48/24																																														
WALL	- 7/16" SE OSB	24/16																																														
	- 19/32" SE OSB	40/20																																														
	- 7/16" ZIP PANEL	24/16																																														
ROOF	- 7/16" SE OSB	24/16																																														
	- 7/16" SE OSB (EACH SHEET MINIMUM DIMENSION)	24/16																																														
LOCATION	R-VALUE	PAPER																																														
FLOOR	R-30	IDENT-FACED																																														
	R-30	IDENT-FACED																																														
WALL	R-13	IDENT-FACED																																														
	R-15	IDENT-FACED																																														
	R-19	IDENT-FACED																																														
	R-21	IDENT-FACED																																														
ROOF	R-30	IDENT-FACED																																														
	R-38	IDENT-FACED																																														
<p style="text-align: center;">SMOKE DEVELOPMENT</p> <ul style="list-style-type: none"> - MAXIMUM SMOKE DEVELOPED INDEX FOR WALL AND CEILING FINISHES SHALL NOT EXCEED 450 - MAXIMUM SMOKE DEVELOPED RATING FOR INSULATION SHALL NOT EXCEED 450 PER ASTM E 84 OR UL 723 																																																

TYPICAL ELECTRICAL NOTES

1. ALL BRANCH CIRCUITS SUPPLYING 15 & 20 AMPERE OUTLETS IN KITCHENS, FAMILY ROOMS, DINING ROOMS, LIVING ROOMS, PARLORS, LIBRARIES, DENS, BEDROOMS, SUNROOMS, RECREATION ROOMS, CLOSETS, HALLWAYS, LAUNDRY AREAS, OR ANY SIMILAR ROOMS OR AREAS, SHALL BE PROTECTED BY AN ARC-FAULT CIRCUIT INTERRUPTER PER SECTION 210.12 OF THE 2017 NEC (NATIONAL ELECTRICAL CODE).
2. BASEMENT PLANS: SMOKE DETECTOR WIRE COILED UNDER FLOOR FOR SITE INSTALLATION OF SMOKE DETECTOR BY THE PURCHASER IN THE BASEMENT AREA. SMOKE DETECTORS WIRED FOR SIMULTANEOUS OPERATION.
3. ALL 125-VOLT, AND 250-VOLT 15-AMPERE & 20-AMPERE RECEPTACLES SHALL BE LISTED TAMPER-RESISTANT RECEPTACLES
4. COMMUNICATIONS OUTLET SUPPLIED & INSTALLED BY PURCHASER AS REQUIRED BY CURRENT NEC, CHAPTER 8

NOTE:
SOFFIT MATERIALS FOR THIS UNIT ASSUMES THAT THE BUILDING FACE WILL BE 10 FT. OR GREATER FROM THE FIRE SEPARATION DISTANCE WHEN INSTALLED ON SITE. WHERE THE BUILDING FACE IS LESS THAN 10 FT. FROM THE FIRE SEPARATION DISTANCE, THE UNDERLAYMENT MATERIALS AND VENTILATION IN ACCORDANCE WITH SECTION R302.1.1 OF THE NC RESIDENTIAL CODE, MUST BE PROVIDED & INSTALLED AT THE SITE WITH INSPECTION AND APPROVAL BY THE LOCAL JURISDICTION.

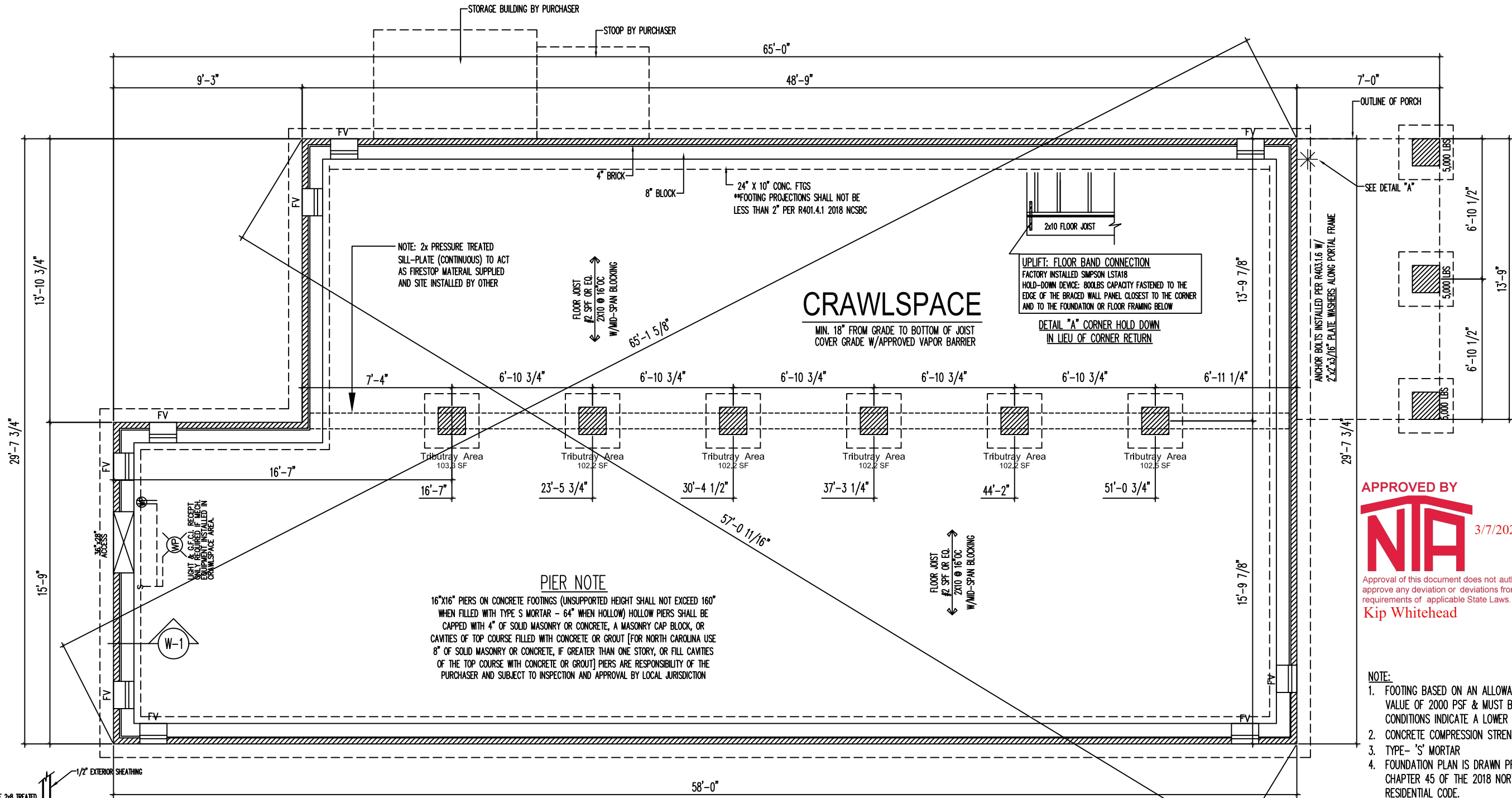

APPROVED BY
NIA 3/7/2024

Approval of this document does not authorize or approve any deviation or deviations from the requirements of applicable State Laws.
Kip Whitehead

- NOTE:**
- FOOTING BASED ON AN ALLOWABLE SOIL BEARING VALUE OF 2000 PSF & MUST BE REVISED IF SITE CONDITIONS INDICATE A LOWER VALUE.
 - CONCRETE COMPRESSION STRENGTH-3000 PSI (MIN)
 - TYPE- 'S' MORTAR
 - FOUNDATION PLAN IS DRAWN PRESCRIPTIVE PER CHAPTER 45 OF THE 2018 NORTH CAROLINA RESIDENTIAL CODE.

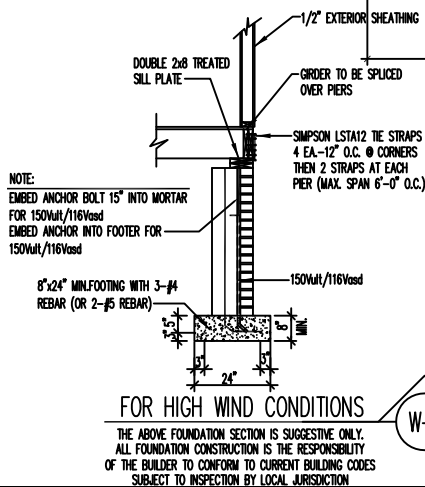

IF FACTORY INSTALLED EXTERIOR RECEPTACLES DO NOT MEET MINIMUM REQUIREMENTS OF THE CURRENT BUILDING CODE, BUILDER MUST SITE INSTALL A FRONT AND REAR RECEPTACLE PER CURRENT BUILDING CODE SUBJECT TO INSPECTION BY LOCAL JURISDICTION

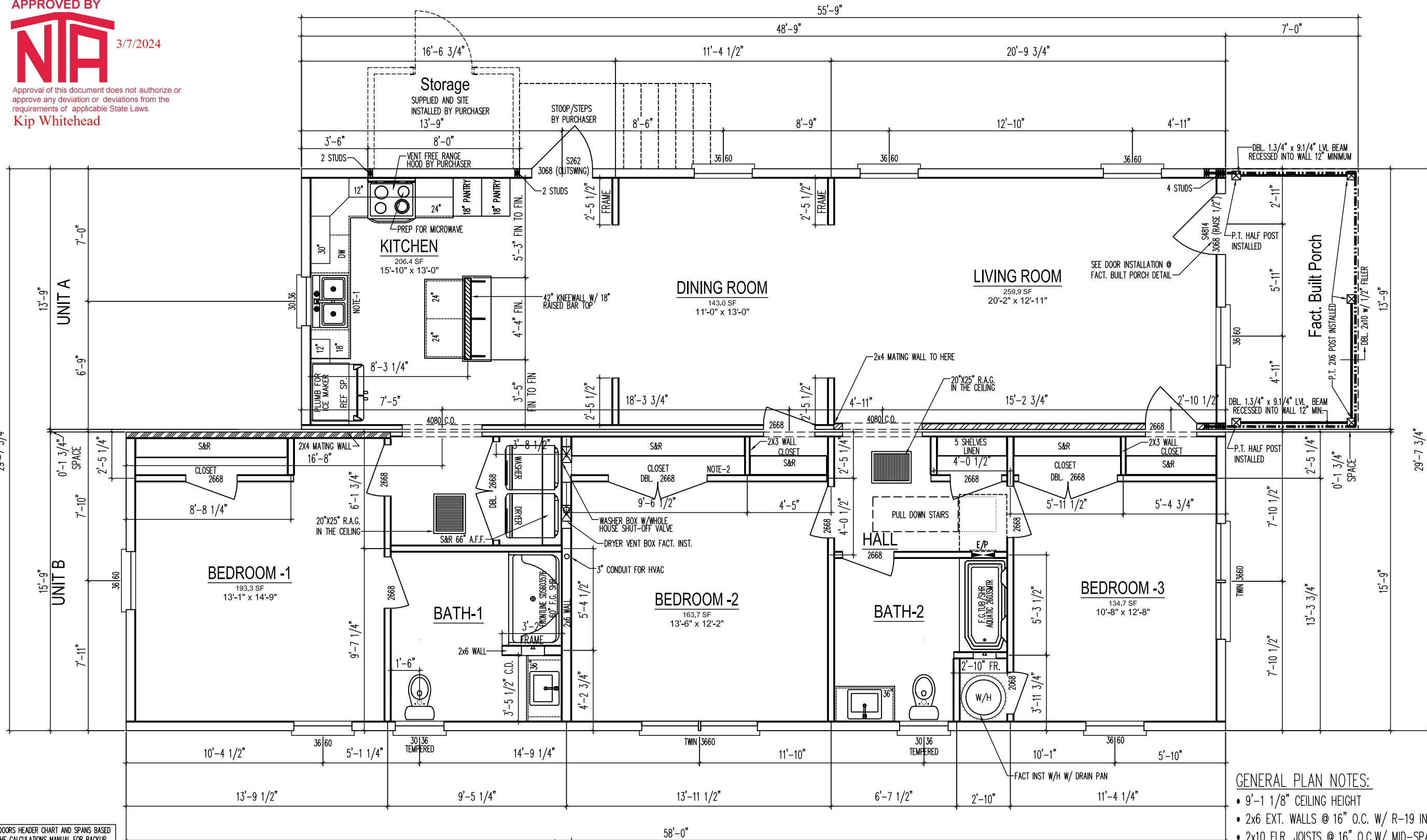

EXTERIOR WINDOWS & DOORS HEADER CHART AND SPANS BASED ON SECTION-36 OF THE CALCULATIONS MANUAL FOR BACKUP

CONDITION	HEADER SIZE	SPAN
1 STORY	(1) 2x10 #2 SYP	10'-3"
1 STORY	(2) 2x10 #2 SYP	14'-6"
1 STORY	(2) 2x12 #2 SYP	16'-0"
2 STORY	(1) 2x10 #2 SYP	4'-11"
2 STORY	(2) 2x10 #2 SYP	6'-11"
2 STORY	(2) 2x12 #2 SYP	8'-0"
2 1/2 STORY or 3 STORY	(2) 2x10 #2 SYP	6'-1"
2 1/2 STORY or 3 STORY	(2) 2x12 #2 SYP	7'-0"

SEE SECTION-36 OF THE CALCULATION MANUAL FOR BACKUP

NC DESIGN PRESSURES FOR DOORS & WINDOWS PER TABLE R4502 (a) OF 2018 N.C.R.C. POSITIVE AND NEGATIVE IN psf

VELOCITY (mph)	MEAN ROOF HEIGHT (ft)		
	15	25	35
130Wht/101Vasd	25	29	32
140Wht/108Vasd	31	35	39
150Wht/116Vasd	37	43	47

NOTE: IF WINDOW OR DOOR IS MORE THAN 4'-0" FROM A CORNER, THE PRESSURE FROM THE TABLE SHALL BE PERMITTED TO BE MULTIPLIED BY 0.87 (THIS ADJUSTMENT DOES NOT APPLY TO GARAGE DOORS)

NOTE: WHERE THE OPENING OF AN OPERABLE WINDOW IS LOCATED MORE THAN 72" ABOVE FINISH GRADE OR SURFACE BELOW, THE LOWEST PART OF THE CLEAR OPENING OF THE WINDOW SHALL BE A MINIMUM OF 24" ABOVE FINISH FLOOR. OPENINGS SHALL BE PROVIDED W/WINDOW GUARDS THAT COMPLY W/ASTM F2090 - SUPPLIED & SITE INSTALLED BY THE PURCHASER PER SECTION 312.2 OF 2018 NORTH CAROLINA RESIDENTIAL CODE.

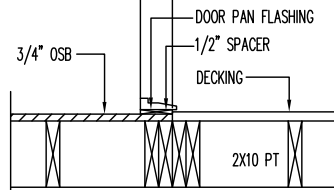

DOOR INSTALLATION @ FACT BUILT PORCH

CERTIFICATION INFORMATION

NOTE-1

- DATA PLATE
- 3rd PARTY INSPECTION LABEL
- STATE LABEL
- INSULATION (NC ONLY)

NOTE-2

- 3rd PARTY INSPECTION LABEL

SQUARE FOOTAGE

TOTAL AVAILABLE SQUARE FOOTAGE	1,615
--------------------------------	-------

GENERAL PLAN NOTES:

- 9'-1 1/8" CEILING HEIGHT
- 2x6 EXT. WALLS @ 16" O.C. W/ R-19 INSULATION
- 2x10 FLR. JOISTS @ 16" O.C. W/ MID-SPAN BLOCKING (MIN R-19 FLOOR INSULATION BY PURCH)
- KINRO SGL. HUNG 4/1 WDWS.
- INTERIOR WALLS @ 16" O.C.
- R-38 ATTIC INSULATION
- 150 Vult / 116 Vasd MPH CONSTRUCTION

FIRST LEVEL FLOOR PLAN

SCALE: 3/16" = 1'-0"

150 Vult / 116 Vasd MPH PRESCRIPTIVE BRACED WALL PANEL DETAIL SHEET (PER 2018 N.C.R.C) CIRCUMSCRIBED METHOD



3/7/2024

APPROVED BY
Approval of this document does not authorize or approve any deviation or deviations from the requirements of applicable State Laws.
Kip Whitehead

1100 RIVES ROAD, WARTONVILLE, VA 24112
(276) 632-7100
WWW.NATIONWIDECUSTOMHOMES.COM

NOTE: ONLY ONE HOUSE MAY BE BUILT UTILIZING THE PLANS THAT ARE DESIGNATED FOR THIS CONTRACT JOB

PURCHASER: Rescue Construction (Jenkins)
JOB NO.: MS-2-24
CONTRACT NO.: 196763

BLACKLINE DATE & BY: 10/17/23 OR
PLAN REVISION DATE: 3.5.2024
BXK01

PLAN NAME: CLARA C
COLLECTION/SERIES: MAINSTREET
© COPYRIGHT 2024 NATIONWIDE HOMES
ALL RIGHTS RESERVED

PAGE NO.

4 of 52

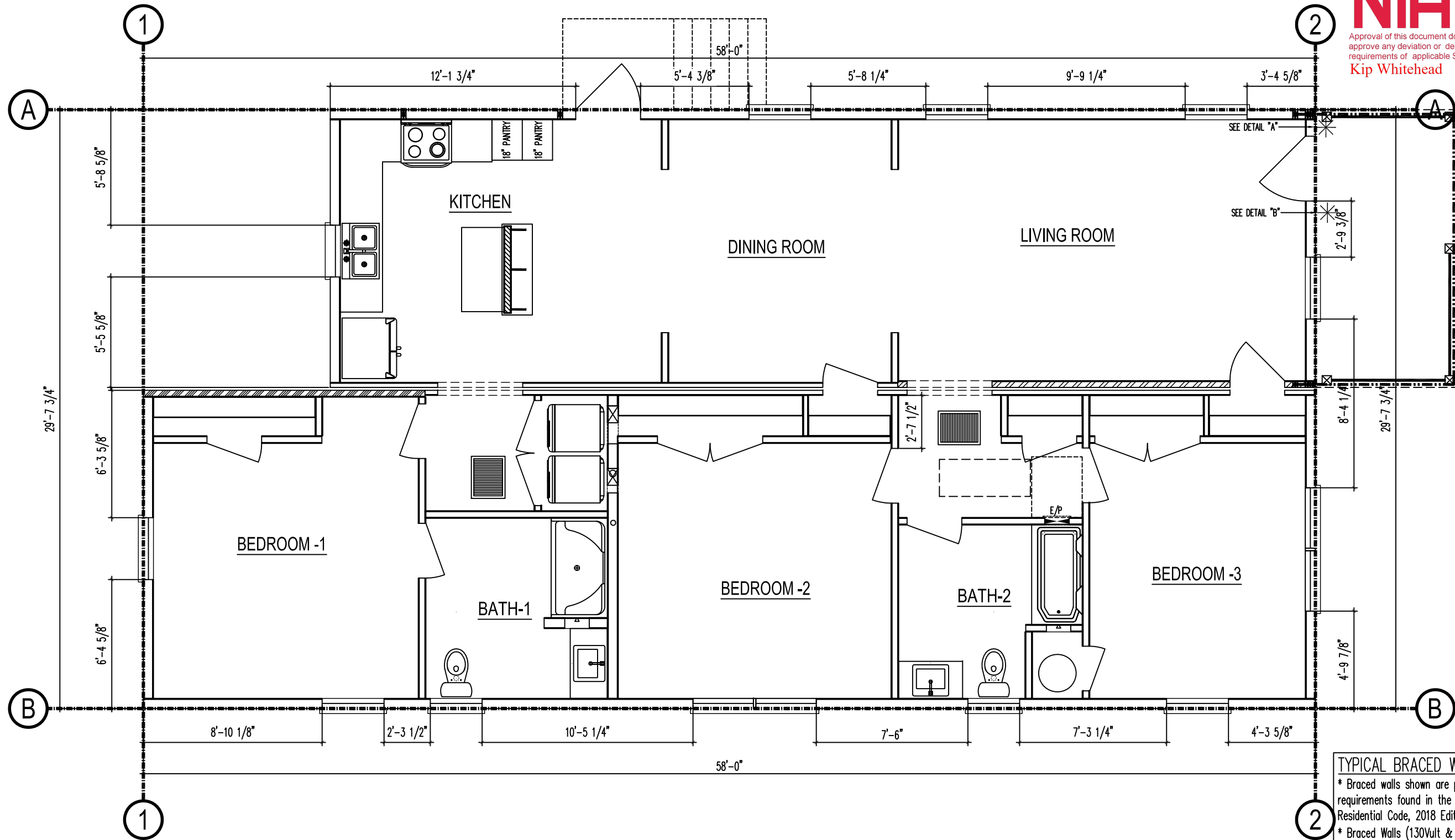

TYPICAL BRACED WALL NOTES:
 * Braced walls shown are per the prescriptive braced wall requirements found in the International North Carolina Residential Code, 2018 Edition.
 * Braced Walls (130Vult & Greater): All exterior walls are to be covered with 7/16" OSB sheathing and classified as braced walls. OSB sheathing is to be fastened to studs with 8d nails 6" on-center at the edge and 12" on center at the field. If less than 50% but more than 25% of the wall is sheathed, then fasten the OSB sheathing with 8d nails 3" on-center at the edge and 6" on center at the field. If less than 25% of the wall is sheathed, then specific braced wall calculations must be designed per an approved engineering practice in lieu of using the prescriptive method.

EXPOSURE CATEGORY-C
 EXTERIOR WALLS 16" O.C. W/ 7/16" SHEATHING
 9'-10" EAVE TO RIDGE HEIGHT
 CEILING HEIGHT = 9'-1 1/8"
 BRACED WALL METHOD = CS-WSP

WALL	BRACED WALL LENGTH	SHEATHED	SHTG COVERAGE	BLOCKED	SHEATHING FASTENING
A	58'-0"	36'-4 1/4"	>50%	YES	8d NAILS 3" EDGE / 6" FIELD
B	58'-0"	40'-7 3/4"	>50%	YES	8d NAILS 3" EDGE / 6" FIELD
1	29'-7 3/4"	23'-10 1/2"	>50%	YES	8d NAILS 3" EDGE / 6" FIELD
2	29'-7 3/4"	15'-11 1/2"	>50%	YES	8d NAILS 3" EDGE / 6" FIELD

APPROVED BY
NIA 3/7/2024
Approval of this document does not authorize or
approve any deviation or deviations from the
requirements of applicable State Laws.
Kip Whitehead

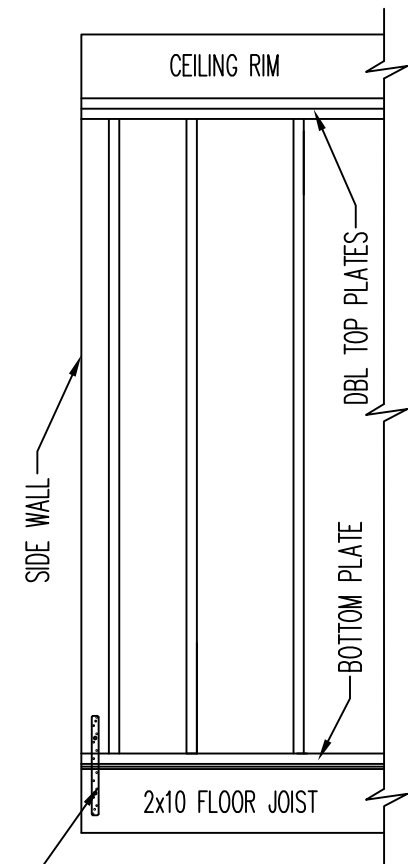

UPLIFT: FLOOR BAND CONNECTION
FACTORY INSTALLED SIMPSON LSTA18
HOLD-DOWN DEVICE: 800LBS CAPACITY FASTENED TO THE
EDGE OF THE BRACED WALL PANEL CLOSEST TO THE CORNER
AND TO THE FOUNDATION OR FLOOR FRAMING BELOW

DETAIL "A" CORNER HOLD DOWN
IN LIEU OF CORNER RETURN

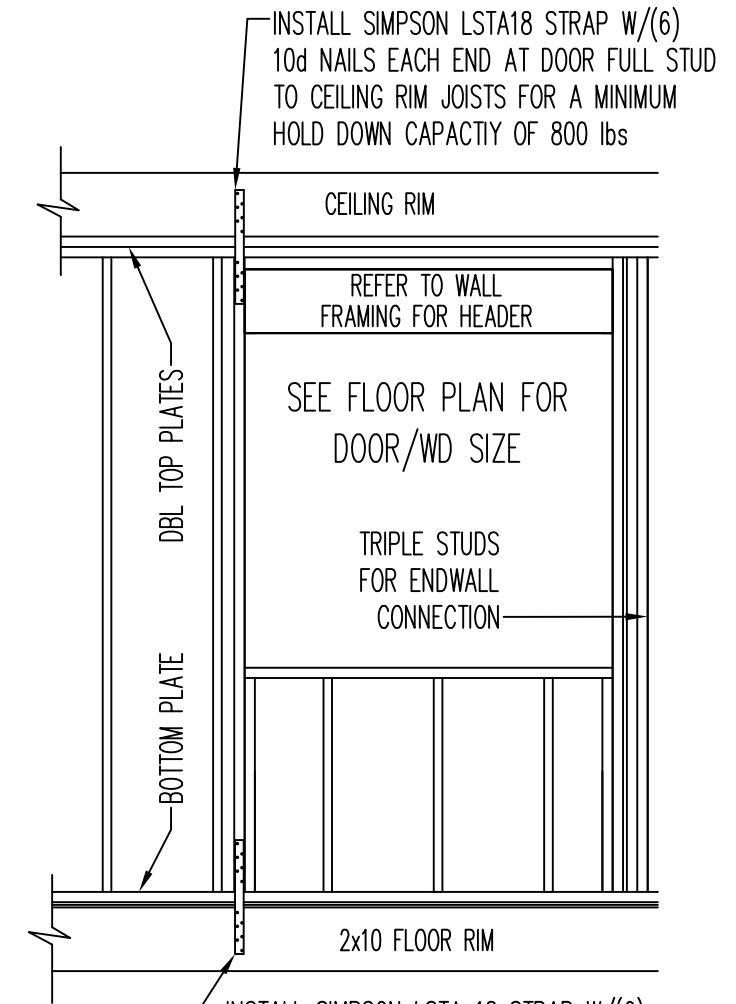

INSTALL SIMPSON LSTA 18 STRAP W/(6)
10d NALS EACH END AT DOOR FULL STUD
TO FLOOR RIM JOIST FOR A MINIMUM
HOLD DOWN CAPACITY OF 800 lbs

DETAIL "B" CORNER HOLD DOWN
IN LIEU OF CORNER RETURN

150 Vult / 116 Vasd MPH PRESCRIPTIVE BRACED WALL PANEL DETAIL SHEET (PER 2018 N.C.R.C) CIRCUMSCRIBED METHOD

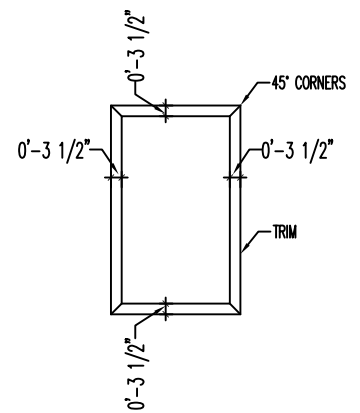
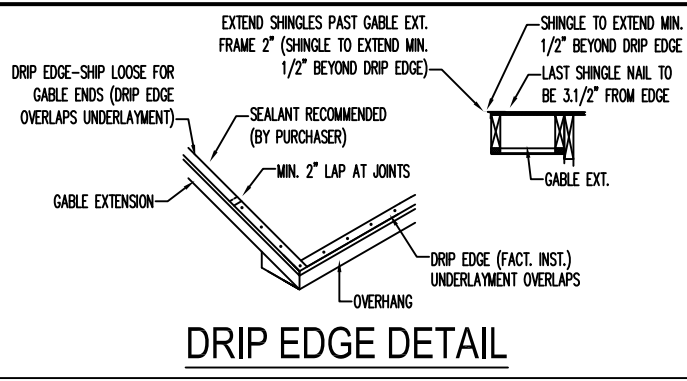

CERTAINEED LANDMARK / TAMCO HERITAGE SHINGLES
 FIRE RESISTANCE:
 •UL 790 CLASS A FIRE RESISTANCE
 •UL CERTIFIED TO MEET ASTM E108 TYPE 1

SIDING CHART

CRANE TRIPLE 6 & DOUBLE 7 SOLID CORE SIDING	BOTTOM ROW OF SIDING SHIPPED
D4, D4.5 & D5 VINYL SIDING	BOTTOM 2 ROWS OF SIDING SHIPPED

VENTILATION CALCULATIONS

RIDGE VENT: 0.139 NET FREE AIR PER SQ.FT.
46.75 LF = 6.50 SQFT. NET FREE AIR
VENTILATED SOFFIT: 0.041 NET FREE AIR PER SQ.FT.
114 LF = 4.67 SQFT. NET FREE AIR

EXTERIOR PORTFOLIO VINYL SIDING & SOFFIT
 FLAME SPREAD-PVC: <25 (ASTM E84) PER SECTION R302.1.2 OF THE 2018 NORTH CAROLINA RESIDENTIAL CODE
 SMOKE DENSITY-PVC: <450 (ASTM E84)

NOTE:
 SOFFIT MATERIALS FOR THIS UNIT ASSUMES THAT THE BUILDING FACE WILL BE 10 FT. OR GREATER FROM THE PROPERTY LINE WHEN INSTALLED ON SITE. WHERE THE BUILDING FACE IS LESS THAN 10 FT. FROM THE PROPERTY LINE, THE UNDERLAYMENT MATERIALS AND VENTILATION IN ACCORDANCE WITH SECTION R302.1.1 OF THE NORTH CAROLINA RESIDENTIAL CODE, MUST BE PROVIDED & INSTALLED AT THE SITE WITH INSPECTION AND APPROVAL BY THE LOCAL JURISDICTION.

APPROVED BY

 3/7/2024
 Approval of this document does not authorize or approve any deviation or deviations from the requirements of applicable State Laws.
Kip Whitehead

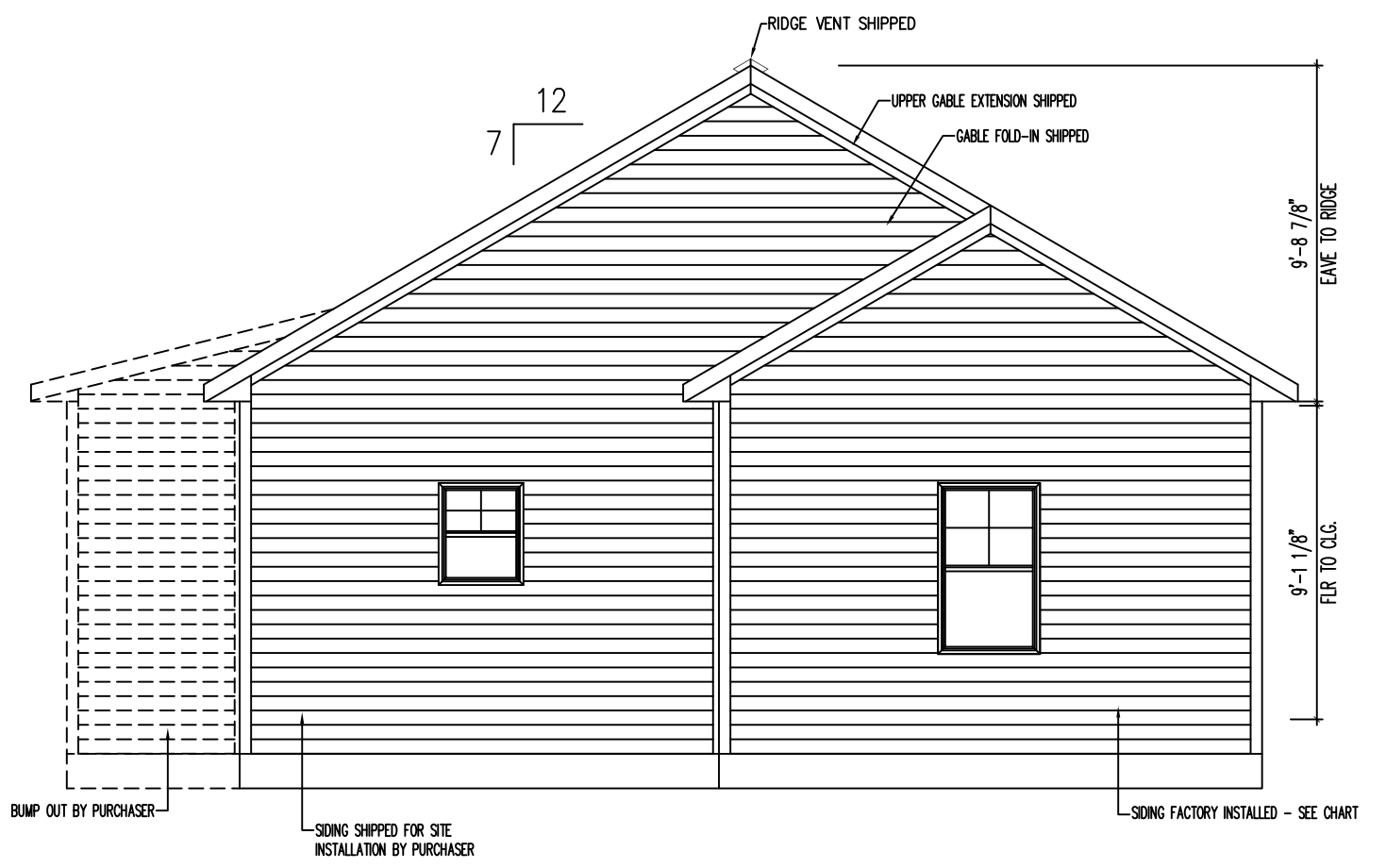
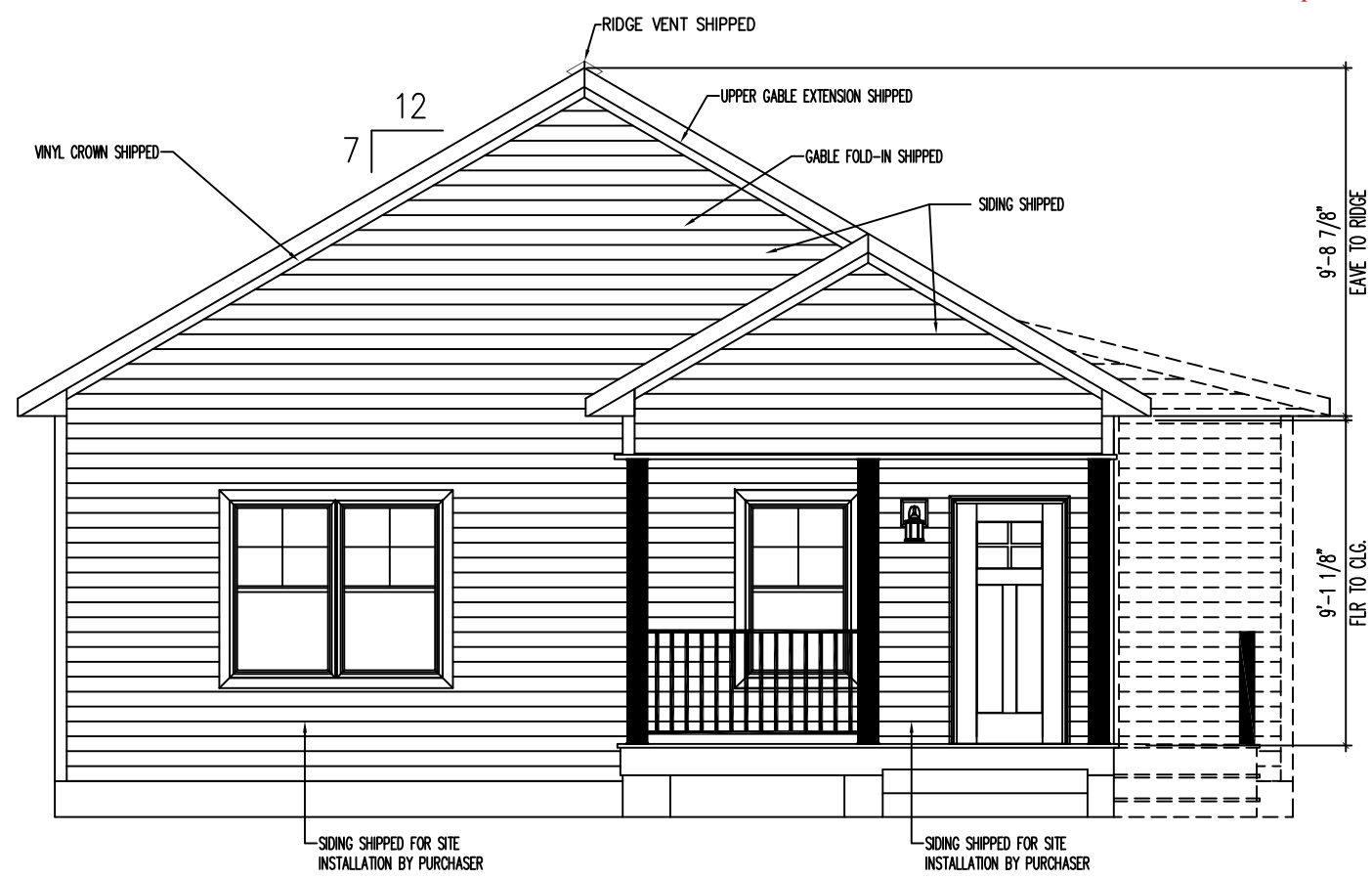

APPROVED BY
NIA 3/7/2024
 Approval of this document does not authorize or approve any deviation or deviations from the requirements of applicable State Laws.
 Kip Whitehead

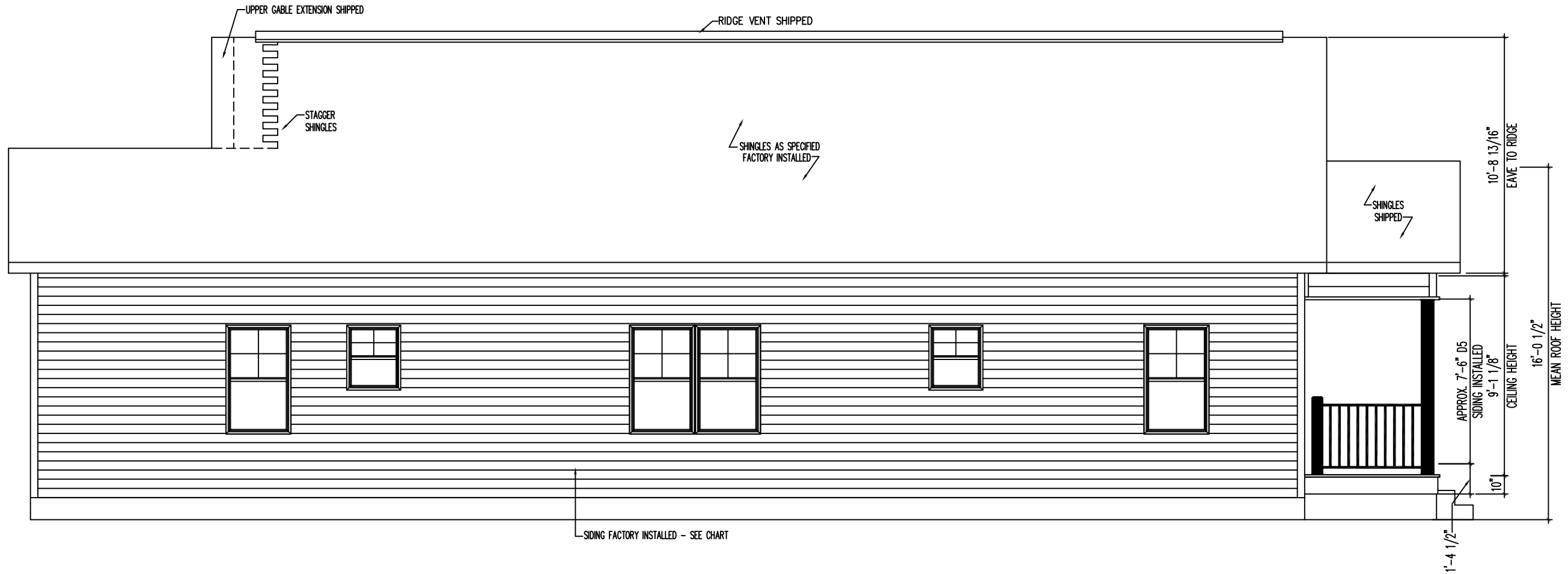

LEFT ELEVATION
 SCALE : 3/16" = 1'-0"

1100 RIVES ROAD, MARTINSVILLE, VA 24112
 (276) 632-7100
 WWW.NATIONWIDECUSTOMHOMES.COM

NOTE: ONLY ONE HOUSE
 MAY BE BUILT UTILIZING
 THE PLANS THAT ARE
 DESIGNATED FOR THIS
 CONTRACT JOB

PURCHASER: Rescue Construction (Jenkins)
 JOB NO.: MS-2-24 CONTRACT NO.: 196763
 BLACKLINE DATE & BY: 10/17/23 OR
 PLAN REVISION DATE: 3.5.2024 BY: 01
 PLOTTED: 3/6/2024 3:14 PM

PLAN NAME: CLARA C
 COLLECTION/SERIES: MAINSTREET
 © COPYRIGHT 2024 NATIONWIDE HOMES
 ALL RIGHTS RESERVED

APPROVED BY
NIA 3/7/2024
 Approval of this document does not authorize or approve any deviation or deviations from the requirements of applicable State Laws.
 Kip Whitehead

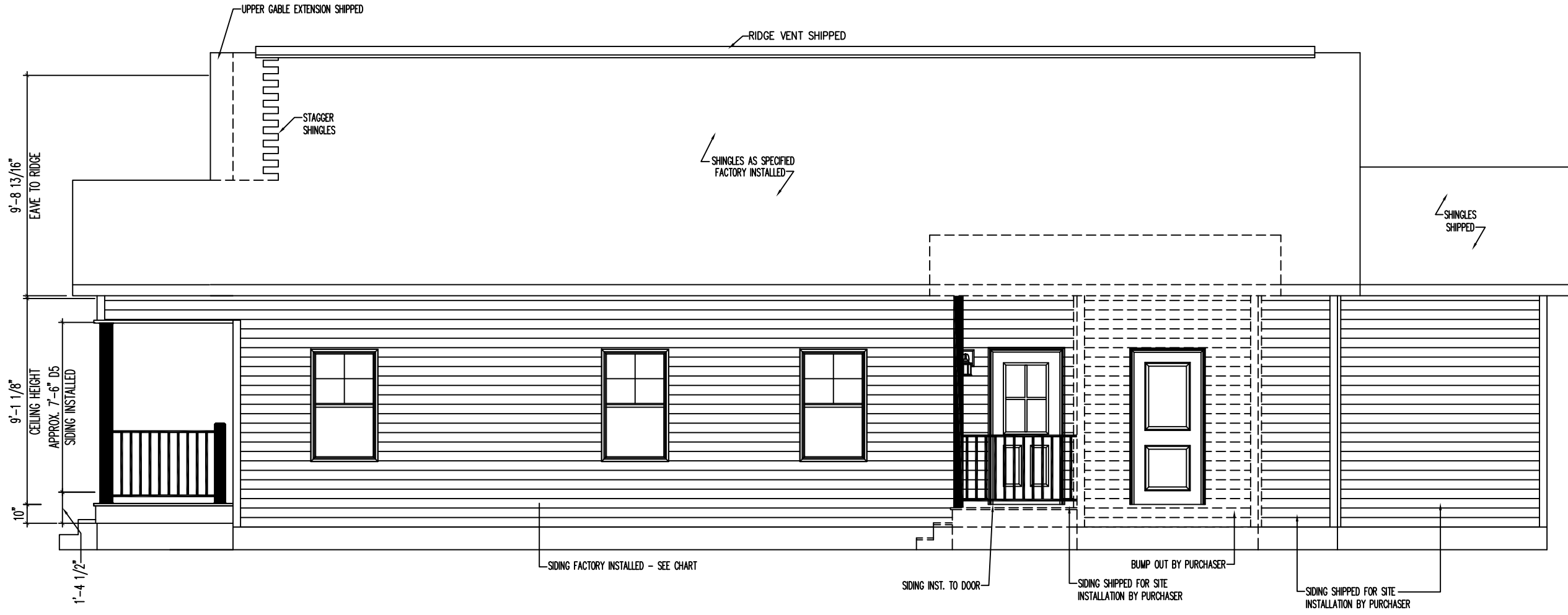

RIGHT ELEVATION
 SCALE : 3/16" = 1'-0"

1100 RIVES ROAD, MARTINSVILLE, VA 24112
 (276) 632-7100
 WWW.NATIONWIDECUSTOMHOMES.COM

NOTE: ONLY ONE HOUSE
 MAY BE BUILT UTILIZING
 THE PLANS THAT ARE
 DESIGNATED FOR THIS
 CONTRACT JOB

PURCHASER: Rescue Construction (Jenkins)
 JOB NO.: MS-2-24 CONTRACT NO.: 196763
 BLACKLINE DATE & BY: 10/17/23 OR
 PLAN REVISION DATE: 3.5.2024 BY: 01/17/24 1:15 PM

PLAN NAME: CLARA C
 COLLECTION/SERIES: MAINSTREET
 © COPYRIGHT 2024 NATIONWIDE HOMES
 ALL RIGHTS RESERVED

PAGE NO.
8 of 52

- Purchaser responsible for all service entry connections to dwelling unit main service panel.
- Purchaser responsible for performing complete circuit testing prior to service connection for all site wiring.
- Exterior weatherproof recepts and light fixtures shipped for site installation by purchaser.
- All gas pipe lines for gas appliances by purchaser.
- All heating / cooling systems supplied and installed by purchaser per state and local codes. When washer/dryer are located in basement, all installation/connections shall be by Purchaser to meet current Bldg./Elec. codes.
- All wiring to be per National Electric Code (Current Edition).
- Unless other wise specified, mount recept. 14" from subfloor to bottom of boxes, switches 48.1/2", Thermostat 60"
- AC/DC smoke detectors wired for simultaneous operation.

- G.F.C.I. recepts wired with feed thru for ground fault protection to all (Load side) branch circuit recept.
- Range hoods are ventless unless otherwise specified.
- All exhaust fans in baths and at dryer shall be vented to the outside air by the purchaser unless otherwise specified.
- Lock-Out clip on water heater & dishwasher.
- Switches & Recept. in bathrooms and dressing rooms over lavinettes to be 46" up.
- Switches and recepts. over counter to be 46" up unless otherwise specified.
- All electrical boxes on exterior walls to be sealed with foam to eliminate air infiltration.
- Batt insulation glued to attic access cover.
- Insulation shipped for site installation by Purchaser. to be installed in gaps at mating wall seams, and at floor & ceiling areas.

- Ceiling angles to be caulked behind crown mould (if crown mould is purchased).
- All exterior wall horizontal sheathing joints to be sealed.
- Interior walls around the perimeter of basement openings to be insulated with R-15.
- Wiring for phone and TV outlets are the responsibility of the purchaser. Nationwide to provide the outlet jack and 2X4 box with 3/4" conduit below subfloor.
- Tamper Resistant Receptacles

FOR NORTH CAROLINA ONLY: REFER TO NATIONWIDE HOMES
 2018 NC Q.A. MANUAL, CHAPTER-12, FOR ELECTRICAL FIXTURES

Duplex Receptacle	Single pole switch	Carbon Monoxide Det.
Weatherproof duplex	Three-way switch	Carb.Mon./Sm.Det. Combo
240v Receptacle	Four-way switch	Wire & Brace (Fan optional)
Quad Receptacle	Television outlet	Exterior Light
Overhead light	Telephone outlet	Push button for chime
LED Recessed / Weatherproof light	Wall Light / Sconce	Flood Light
Fluorescent light	Thermostat	Wireless Door Chime
Light/Clg. Exh. fan (50 CFM Min)	Heat/Fan/Light	4 x 10 Registers
Clg. Exh. fan (50 CFM Min)	Smoke Detector	Toe-Kick Registers

APPROVED BY

 3/7/2024
 Approval of this document does not authorize or approve any deviation or deviations from the requirements of applicable State Laws.
 Kip Whitehead

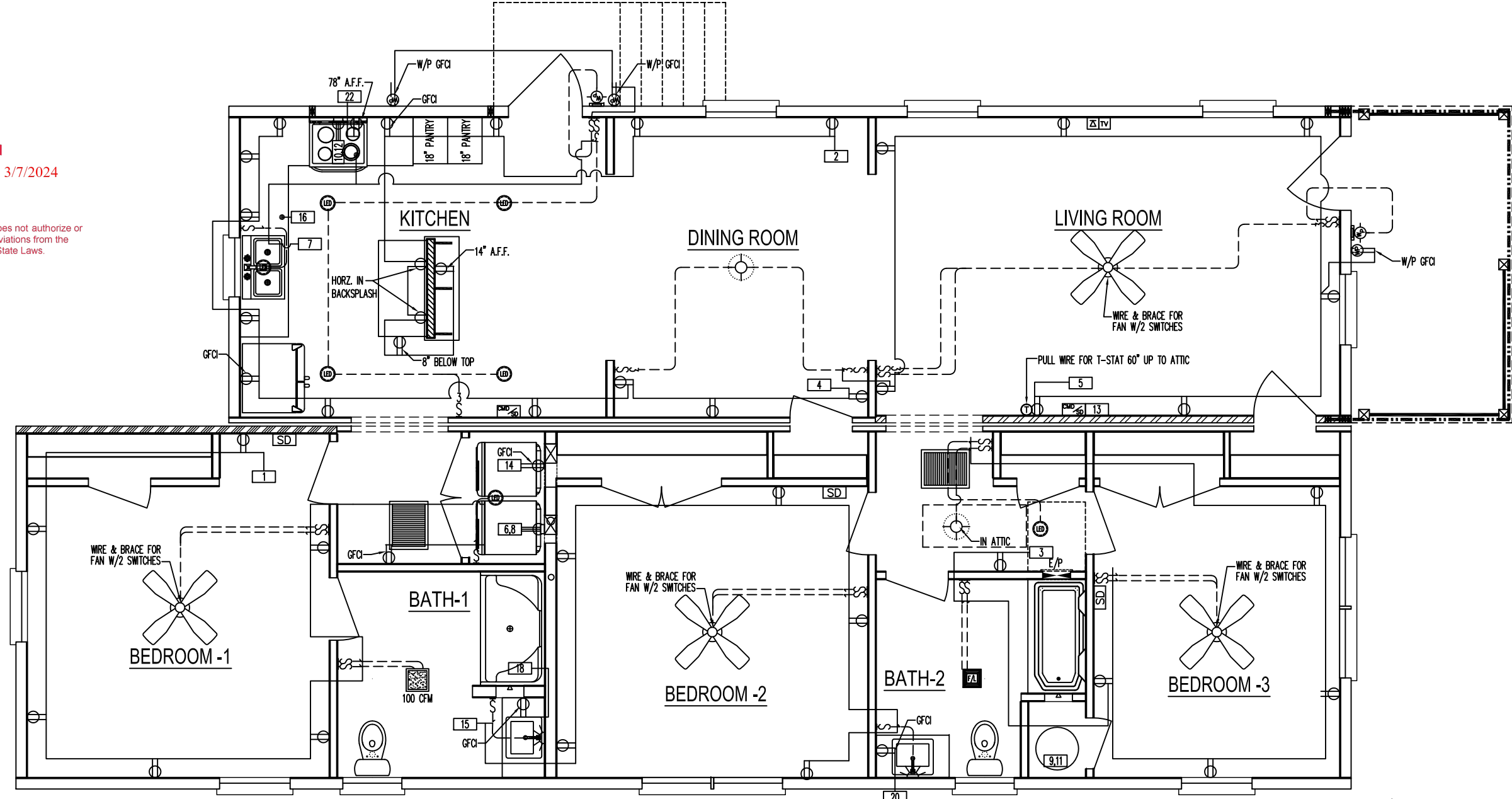

*ELECTRICAL DEVICES HAVE BEEN LOCATED PER PURCHASER REQUEST

NOTE: ALL WIRES IN ATTIC INST. BESIDE OR THRU JOISTS OR PROTECTED BY GUARD STRAPS

HVAC SYSTEM DESIGNED, ENGINEERED, AND SITE INSTALLED BY HVAC CONTRACTOR. ALL DUCTWORK, AIR HANDLER, A-COIL, FLOOR OR CEILING REGISTERS SUPPLIED & SITE INSTALLED BY THE HVAC CONTRACTOR ON SITE SUBJECT TO INSPECTION AND APPROVAL BY LOCAL JURISDICTION

MECHANICAL VENTILATION PER TABLE M1507.3.3(1)			
CODE REQUIRED VENTILATION IN CFM FAN CFM (BASED ON # OF BEDROOMS)	HOUR FRACTION	VENTILATION SETTINGS IN MINUTES/HOUR	
60	100	0.6000	36.00

WHOLE HOUSE VENTILATION REQUIRED PER SECTION M1507 OF NC RESIDENTIAL CODE 2018 TO BE PROVIDED BY WAY OF A 100 CFM EXHAUST FAN LOCATED IN THE MASTER BATHROOM

NOTE: ALL BRANCH CIRCUITS THAT ARE SUPPLYING 15 & 20 AMP OUTLETS IN ALL BEDROOMS, KITCHENS, DINING ROOM, BREAKFAST ROOM, PARLORS, LIBRARIES, DENS FAMILY ROOM, SUNROOMS, RECREATION ROOMS, CLOSETS, HALLWAYS, LAUNDRY AREAS OR SIMILAR AREAS, TO BE PROTECTED BY ARC-FAULT CIRCUIT INTERRUPTER IN PERSECTION 210.12, 2017 NEC ELECTRICAL CODE.

IF FACTORY INSTALLED EXTERIOR RECEPTACLES DO NOT MEET MINIMUM REQUIREMENTS OF THE CURRENT BUILDING CODE, BUILDER MUST SITE INSTALL A FRONT AND REAR RECEPTACLE PER CURRENT BUILDING CODE SUBJECT TO INSPECTION BY LOCAL JURISDICTION

EXTERIOR RECEPTACLE OUTLET BOX HOODS THAT ARE A PART OF THE WEATHERPROOF ENCLOSURE TO BE LISTED AND IDENTIFIED AS "EXTRA DUTY" DURABILITY TO RETAIN A DEGREE OF PROTECTION FOR THE RECEPTACLES.

FIRST LEVEL ELECTRICAL PLAN

SCALE: 3/16" = 1'-0"

FOR NORTH CAROLINA ONLY: REFER TO NATIONWIDE HOMES 2018 NC Q.A. MANUAL, CHAPTER-10, FOR ALL APPLIANCES

1. CABINET CONFIGURATION MAY VARY TO CABINET STYLE SELECTED
2. MIN. 30" CLARENCE BETWEEN RANGE AND COMBUSTIBLE SURFACE ABOVE
3. MIN. 1" CLARENCE FROM RANGE EXHAUST VENT TO COMBUSTIBLE MATERIAL
4. VENTLESS RANGE HOOD UNLESS OTHERWISE NOTED.

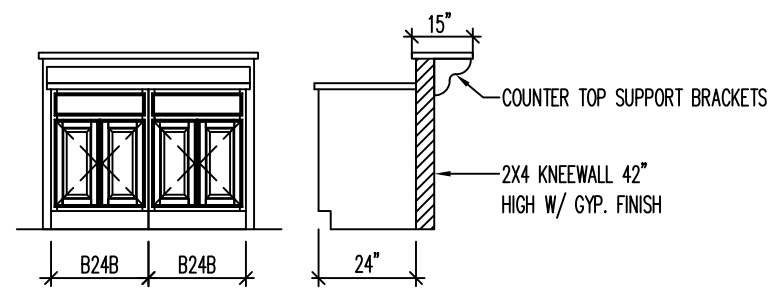
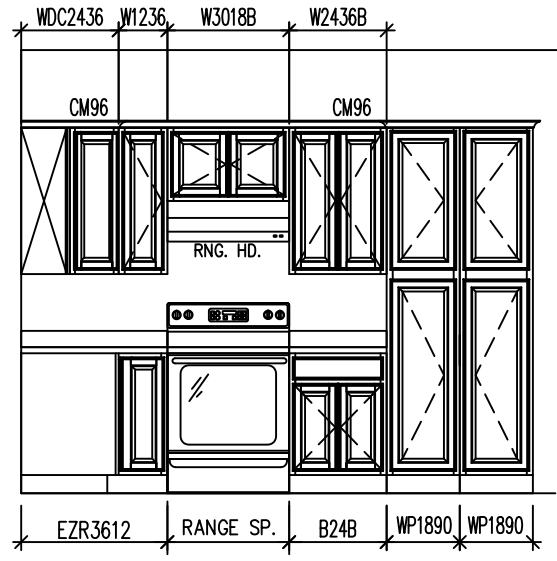
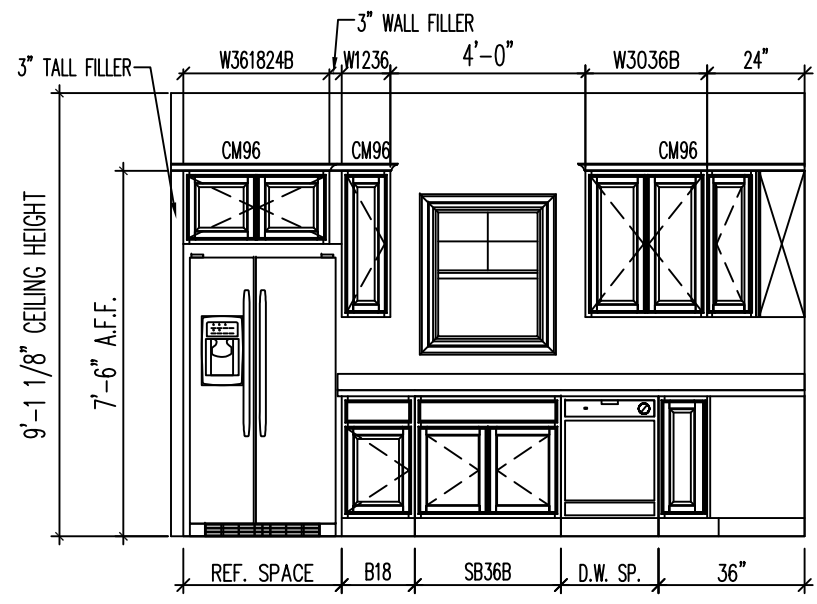

KITCHEN CABINET LAYOUT

MATCHING TOE KICK COVERS

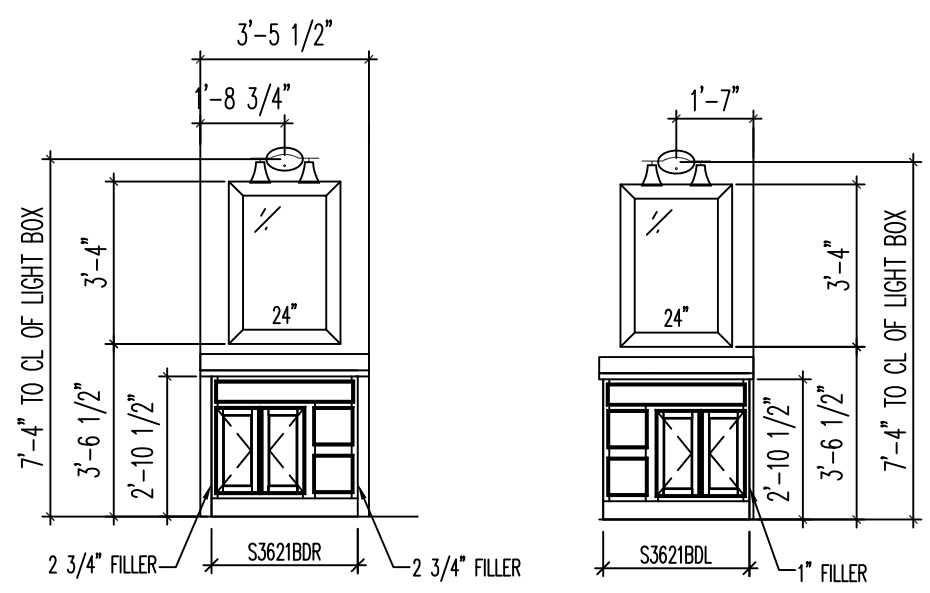

BATHROOM CABINETS

MATCHING TOE KICK COVERS

APPROVED BY
NIA 3/7/2024
Approval of this document does not authorize or approve any deviation or deviations from the requirements of applicable State Laws.
Kip Whitehead

TRAP SIZE	FALL PER FOOT	DISTANCE TO VENT FROM TRAP	ALL FACTORY INSTALLED PLUMBING TO CONFORM TO: CURRENT PLUMBING CODE (SEE COVER SHEET)
1 1/4"	1/4"	3 Ft. 6 In.	REFER TO PLUMBING NOTES ON COVER SHEET FOR ADDITIONAL INFORMATION
1 1/2"	1/4"	5 Ft. 0 In.	
2"	1/4"	6 Ft. 0 In.	
3"	1/4"	10 Ft. 0 In.	
4"	1/8"	12 Ft. 0 In.	

NOTE: APPROVED ENGINEERED MECHANICAL WATER HAMMER ARRESTERS FOR QUICK CLOSING VALVES FACT. INST. AT ICEMAKER, DISHWASHER & WASHING MACHINE AS REQUIRED BY CURRENT STATE PLUMBING CODES.

FOR NORTH CAROLINA ONLY: REFER TO NATIONWIDE HOMES 2018 NC Q.A. MANUAL, CHAPTER-11, FOR ALL PLUMBING FIXTURES

- * PEX PLUMBING FOR SUPPLY LINES
- * GLUE P-TRAPS AT ALL TUBS AND SHOWERS
- * PEX SUPPLY LINES SHALL HAVE A MAXIMUM SUPPORT SPACING OF 32 INCHES.
- * PROTECTION FROM FREEZING SHALL COMPLY WITH SECTION P2603.5 OF THE 2018 NCRC

APPROVED BY
NIA 3/7/2024
Approval of this document does not authorize or approve any deviation or deviations from the requirements of applicable State Laws.
Kip Whitehead

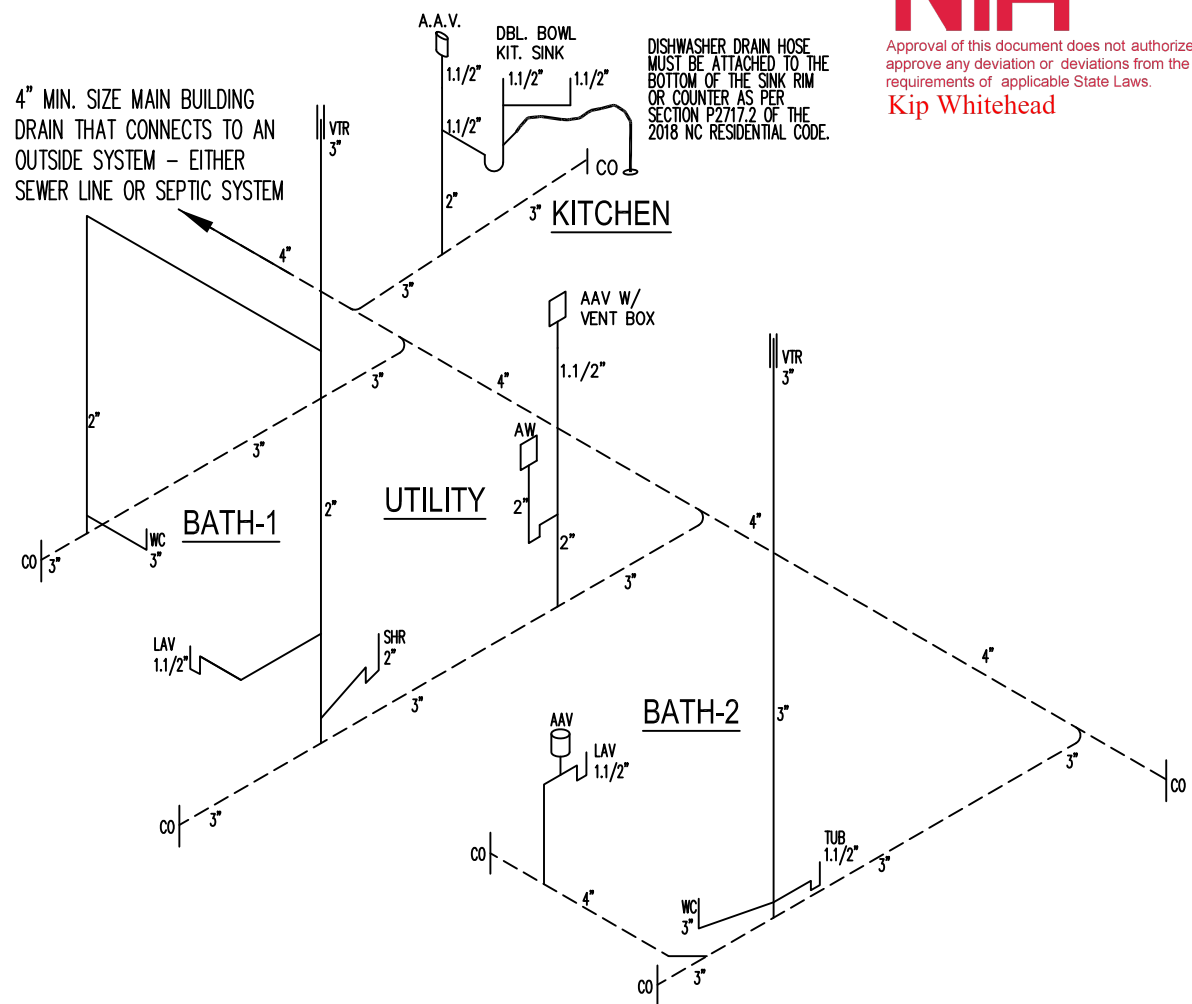

PLUMBING SCHEMATIC

PANEL SCHEDULE

* LOCKOUT BREAKER INSTALLED ON WATER HEATER & DISHWASHER

AMP	WIRE SIZE	200 AMP PANEL				WIRE SIZE	AMP		
20	12/2	AFCI	GENERAL WIRING	1	2	SMALL APPLIANCE	AFCI	12/2	20
20	12/2	AFCI	GENERAL WIRING	3	4	SMALL APPLIANCE	AFCI	12/2	20
20	12/2	AFCI	GENERAL WIRING	5	6	DRYER	240V	10/3 WG	30
20	12/2	AFCI	GENERAL WIRING	7	8	DRYER		10/3 WG	30
25	10/2	240V	* WATER HEATER	9	10	RANGE	240V	8/3 CU	40
25	10/2		WATER HEATER	11	12	RANGE		8/3 CU	40
15	14/3	AFCI	SMOKE DETECTOR/CMD	13	14	WASHER	AFCI	12/2	20
20	12/2	AFCI	GENERAL WIRING	15	16	* DISHWASHER	AFCI/GFCI	12/2	20
				17	18	BATH-1 RECEPT		12/2	20
				19	20	BATH-2 RECEPT		12/2	20
				21	22	MICROWAVE	AFCI	12/2	20
				23	24				
				25	26				
				27	28				
				29	30				
				31	32				
				33	34				
				35	36				
				37	38				
				39	40				

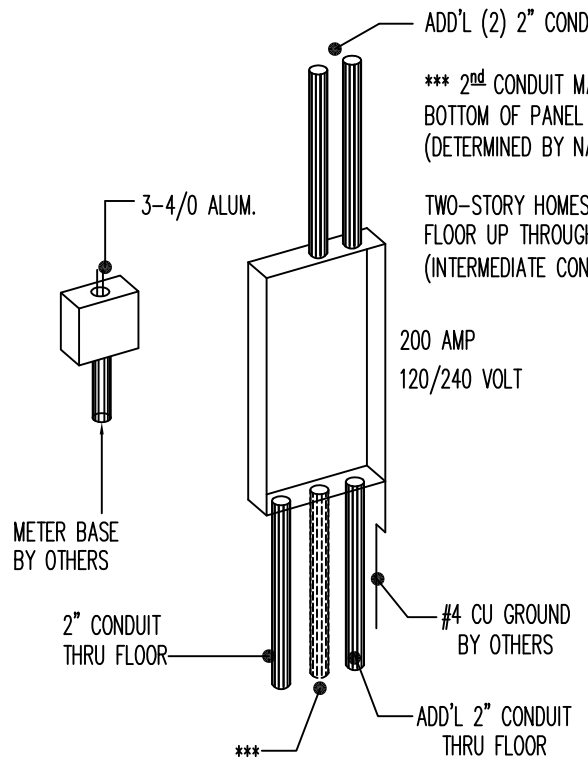

TYP. SERVICE ENTRY INSTALLATION

1. CONNECTION TO SERVICE BY OTHERS
2. 2 EA. 2" CONDUIT DROPPED THRU FLOOR FOR SITE ELECTRICAL INSTALLATION BY OTHERS.
3. METER BASE BY OTHERS TO BE LOCATED WITHIN 30" OF ELEC. PANEL STUB-OUT.
4. CHECK LOCAL CODE & POWER CO. REQUIREMENTS FOR ANY ADDITIONAL SITE RELATED INSTALLATION.
5. CIRCUIT BREAKERS SUPPLIED AND SITE INSTALLED BY THE PURCHASER AT UNFINISHED AREA'S.
6. PURCHASER / SITE CONTRACTOR IS RESPONSIBLE TO PROPERLY DRAFT-STOP CONDUITS UPON COMPLETION OF WORK

1100 RIES ROAD, WARTNSVILLE, VA 24112
(776) 632-7100
WWW.NATIONWIDECUSTOMHOMES.COM

NOTE: ONLY ONE HOUSE MAY BE BUILT UTILIZING THE PLANS THAT ARE DESIGNATED FOR THIS CONTRACT JOB

PURCHASER: Rescue Construction (Jenkins)
JOB NO.: MS-2-24
CONTRACT NO.: 196763
BLACKLINE DATE & BY: 10/17/23 OR
PLAN REVISION DATE: 3/5/2024
BWK01

PLAN NAME: CLARA C
COLLECTION/SERIES: MAINSTREET
© COPYRIGHT 2024 NATIONWIDE HOMES
ALL RIGHTS RESERVED

TYPICAL PLUMBING NOTES

1. WATER DISTRIBUTION SYSTEM PIPE SHALL BE PEX PIPE (STD) SUPPORTED AT 32" INTERVALS.
2. FITTINGS & CONNECTIONS SHALL BE PEX WITH COMPRESSION RINGS INSTALLED PER MANUFACTURER'S INSTALLATION INSTRUCTIONS. FIXTURES VALVES SHALL HAVE COMPRESSION CONNECTION FITTINGS INSTALLED PER MANUFACTURER'S INSTALLATION INSTRUCTIONS.
3. COPPER SUPPLY LINES TO BE INSTALLED A MINIMUM 18" FROM WATER HEATER OUTLET BEFORE CONNECTION TO "PEX" PIPING.
4. BUILDER TO INSTALL BACKFLOW PREVENTERS ON EXTERIOR AND/OR OTHER FAUCETS WHERE REQ'D BY PUMING CODE.
5. BUILDING TO SUPPLY & INSTALL COPPER T & P RELIEF LINE AND EXTEND TO BUILDING EXTERIOR.
6. OVER AREA SUBJECT TO WATER DAMAGE, BUILDER SHALL INSTALL A 24 GAUGE GALVANIZED METAL DRAIN PAN w/ MIN. 1" DRAIN EXTENDED TO BLDG. BELOW WATER HEATERS.
7. AS DICTATED BY THE SERVICE AVAILABLE, THE BUILDER SHALL INSTALL WATER HAMMER ARRESTORS (AIR CHAMBERS, PRESSURE REDUCING VALVES, ETC.) ON THE WATER DISTRIBUTION SYSTEM TO REGULATE THE VELOCITY OF THE FLOW & LESSEN THE HYDRAULIC SHOCK OF QUICK-CLOSING VALVES & FAUCETS.
8. WATER HEATER EQUIPPED W/DIP TUBE TO PREVENT SIPHONING OF WATER FROM TANK BACK INTO WATER SUPPLY LINES.
9. ALL WATER HEATER TANKS SHALL BE EQUIPPED WITH DRAIN COCKS AT BASE OF TANK FOR EMPTYING.
10. ALL SUPPLY LINES RAN IN LOOP FASHION PER MODULE TO CONNECTION POINT AT MATELINE. PURCHASER TO MAKE CONNECTION FROM MODULE TO MODULE ON SITE.
11. MAXIMUM LENGTH OF INDIVIDUAL DISTRIBUTION LINES SHALL NOT EXCEED 60 FT.

NOTE: APPROVED ENGINEERED MECHANICAL WATER HAMMER ARRESTERS FOR QUICK CLOSING VALVES FACTORY INSTALLED WHERE REQUIRED BY CODE

NOTE: PEX PLUMBING PIPE TO BE SUPPORTED AT 32" INTERVALS AND PROTECTED FROM FREEZING

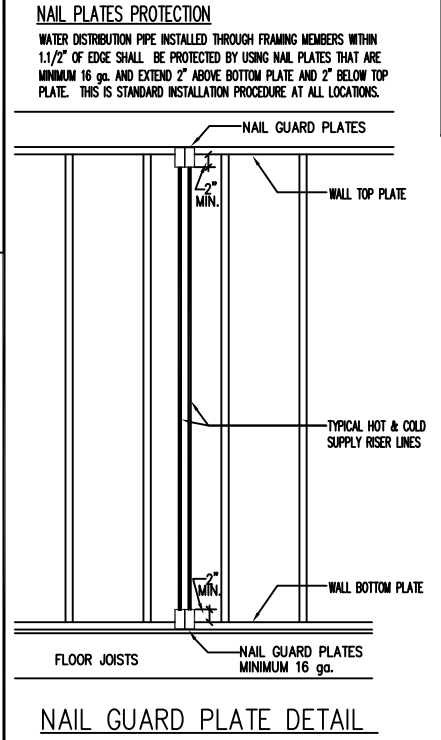
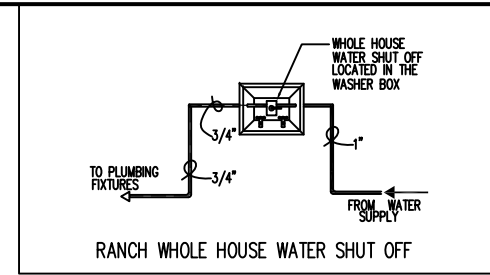

1100 RIES ROAD, MARTINSVILLE, VA 24112
(276) 632-7100
WWW.NATIONWIDECUSTOMHOMES.COM

NOTE: ONLY ONE HOUSE MAY BE BUILT UTILIZING THE PLANS THAT ARE DESIGNATED FOR THIS CONTRACT JOB

PURCHASER: Rescue Construction (Jenkins)
JOB NO.: MS-2-24
CONTRACT NO.: 196763
BLACKLINE DATE & BY: 10/17/23 OR
PLAN REVISION DATE: 3.5.2024
BANK01

PLAN NAME: CLARA C
COLLECTION/SERIES: MAINSTREET
© COPYRIGHT 2024 NATIONWIDE HOMES
ALL RIGHTS RESERVED

SUPPLY RISER SCHEMATIC - COLD

"PEX" (HIGH DENSITY CROSS LINKED POLYETHYLENE)

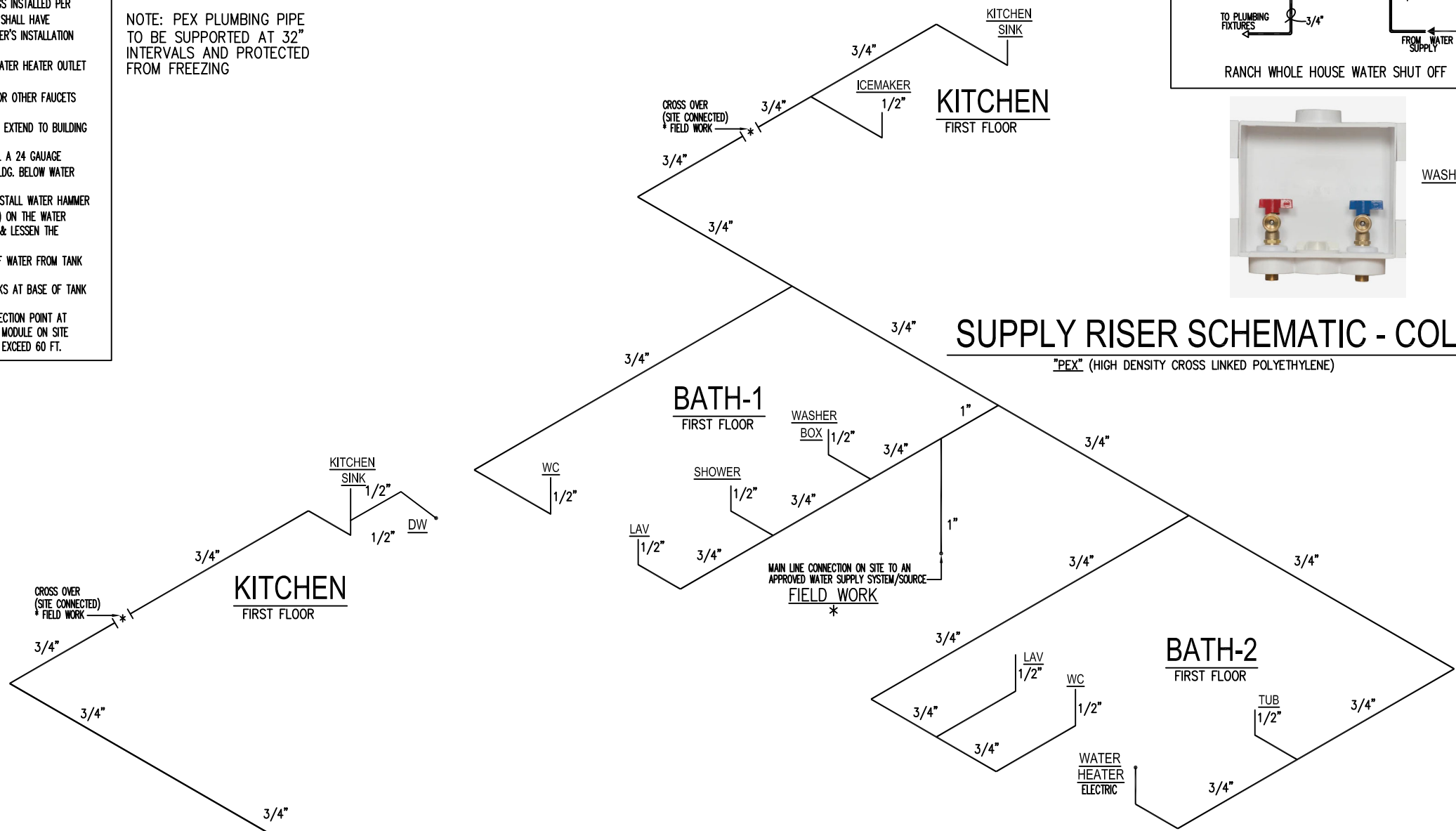

SUPPLY RISER SCHEMATIC - HOT

"PEX" (HIGH DENSITY CROSS LINKED POLYETHYLENE)

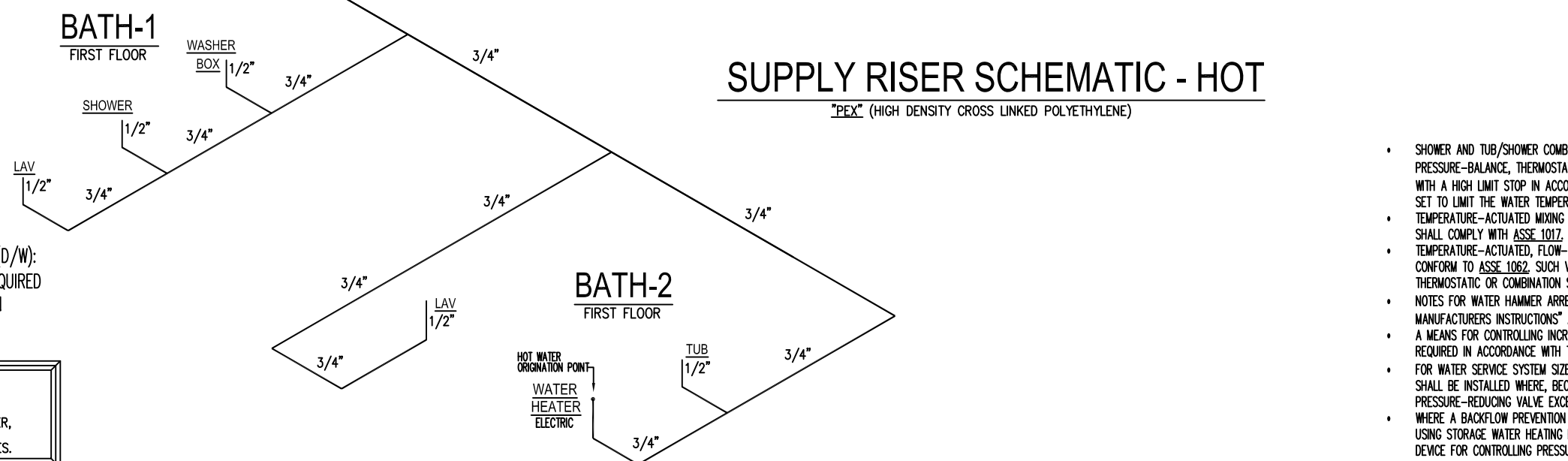

APPROVED BY
NIA
3/7/2024
Approval of this document does not authorize or approve any deviation or deviations from the requirements of applicable State Laws.
Kip Whitehead

GENERAL NOTE REGARDING DISHWASHER (D/W):
DISCONNECTING MEANS FOR D/W NOT REQUIRED PER 2017 NEC ELECTRICAL CODE SECTION 422.34 UNIT SWITCH (ES)

NOTE:
APPROVED ENGINEERED MECHANICAL WATER HAMMER ARRESTORS, FOR ALL QUICK CLOSING VALVES, ARE FACTORY INSTALLED AT ICEMAKER, DISHWASHER, AND WASHING MACHINE AS REQUIRED BY CURRENT STATE PLUMBING CODES.

- SHOWER AND TUB/SHOWER COMBINATION VALVES SHALL BE EQUIPPED WITH CONTROL VALVES OF THE PRESSURE-BALANCE, THERMOSTATIC-MIXING OR COMBINATION PRESSURE-BALANCE/THERMOSTATIC-MIXING VALVE TYPES WITH A HIGH LIMIT STOP IN ACCORDANCE WITH ASSE 1016/ASME A112.1016/CSA B125.16. THE HIGH LIMIT STOP SHALL BE SET TO LIMIT THE WATER TEMPERATURE TO NOT GREATER THAN 120°F.
- TEMPERATURE-ACTUATED MIXING VALVES, WHICH ARE INSTALLED TO REDUCE WATER TEMPERATURES TO DEFINED LIMITS, SHALL COMPLY WITH ASSE 1017. SUCH VALVES SHALL BE INSTALLED AT THE HOT WATER SOURCE.
- TEMPERATURE-ACTUATED, FLOW-REDUCTION DEVICES, WHERE INSTALLED FOR INDIVIDUAL FIXTURE FITTINGS, SHALL CONFORM TO ASSE 1062. SUCH VALVES SHALL NOT BE USED AS A SUBSTITUTE FOR THE BALANCED PRESSURE, THERMOSTATIC OR COMBINATION SHOWER VALVES REQUIRED FOR SHOWERS IN SECTION P2708.4.
- NOTES FOR WATER HAMMER ARRESTORS - "WATER HAMMER ARRESTORS CONFORMING TO ASSE 1010 AND INSTALLED PER MANUFACTURERS INSTRUCTIONS" AND "NOT REQUIRED FOR PLASTIC WATER DISTRIBUTION PIPE"
- A MEANS FOR CONTROLLING INCREASED PRESSURE CAUSED BY THERMAL EXPANSION SHALL BE INSTALLED WHERE REQUIRED IN ACCORDANCE WITH THE FOLLOWING:
- FOR WATER SERVICE SYSTEM SIZES UP TO AND INCLUDING 2 INCHES (51 MM), A DEVICE FOR CONTROLLING PRESSURE SHALL BE INSTALLED WHERE, BECAUSE OF THERMAL EXPANSION, THE PRESSURE ON THE DOWNSTREAM SIDE OF A PRESSURE-REDUCING VALVE EXCEEDS THE PRESSURE-REDUCING VALVE SETTING.
- WHERE A BACKFLOW PREVENTION DEVICE, CHECK VALVE OR OTHER DEVICE IS INSTALLED ON A WATER SUPPLY SYSTEM USING STORAGE WATER HEATING EQUIPMENT SUCH THAT THERMAL EXPANSION CAUSES AN INCREASE IN PRESSURE, A DEVICE FOR CONTROLLING PRESSURE SHALL BE INSTALLED.

WHERE A SINGLE STORY MODULE JOINS A MULTI-STORY FOLLOW THESE GUIDELINES:

BATT INSULATION SHIPPED FOR SITE INSTALLATION AFTER SET

ATTIC SPACE

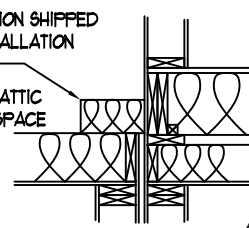

FOAM SEAL LIGHTS, BATH FANS, SPEAKERS, ETC. TO CEILING DRYWALL. USE AIR TIGHT IC-RATED RECESSED CANS AND COVER W/ INSULATION

INSULATE AND INSTALL GYPSUM WALL BOARD BEHIND BATHTUB AND SHOWERS ON EXTERIOR WALLS AND ATTIC WALLS. ALSO, SEAL BATHTUB AND SHOWER DRAIN PENETRATIONS. CUT-OUTS FOR TUB AND SHOWER DRAIN PENETRATIONS ARE TO BE MINIMAL.

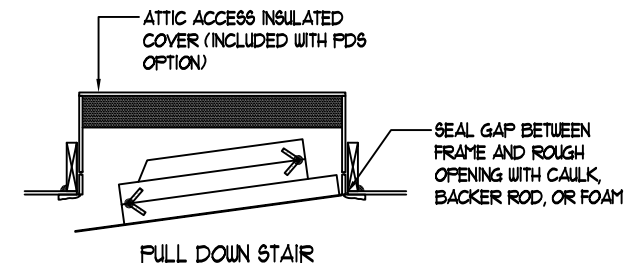
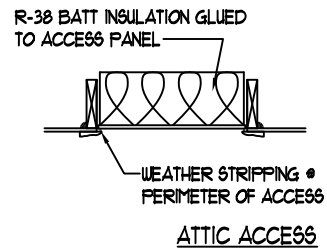

KNEEWALL ACCESS - BUILDER TO WEATHER STRIP DOOR OPENING & THRESHOLD AND APPLY RIGID INSULATION TO ACCESS DOOR (MINIMUM R-3)

APPROVED BY
NIA 3/7/2024
Approval of this document does not authorize or approve any deviation or deviations from the requirements of applicable State Laws.
Kip Whitehead

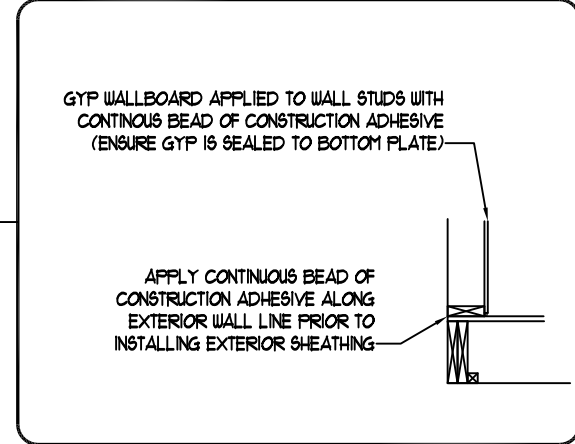
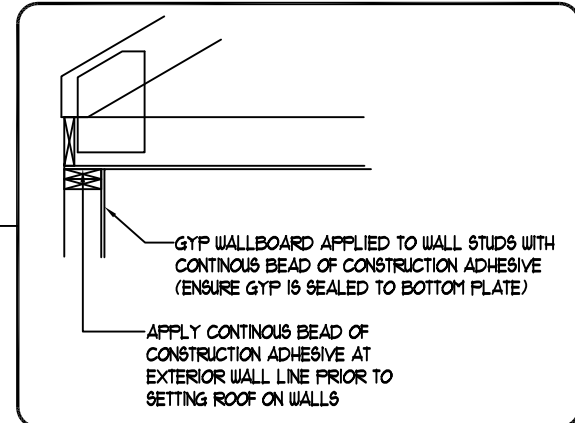
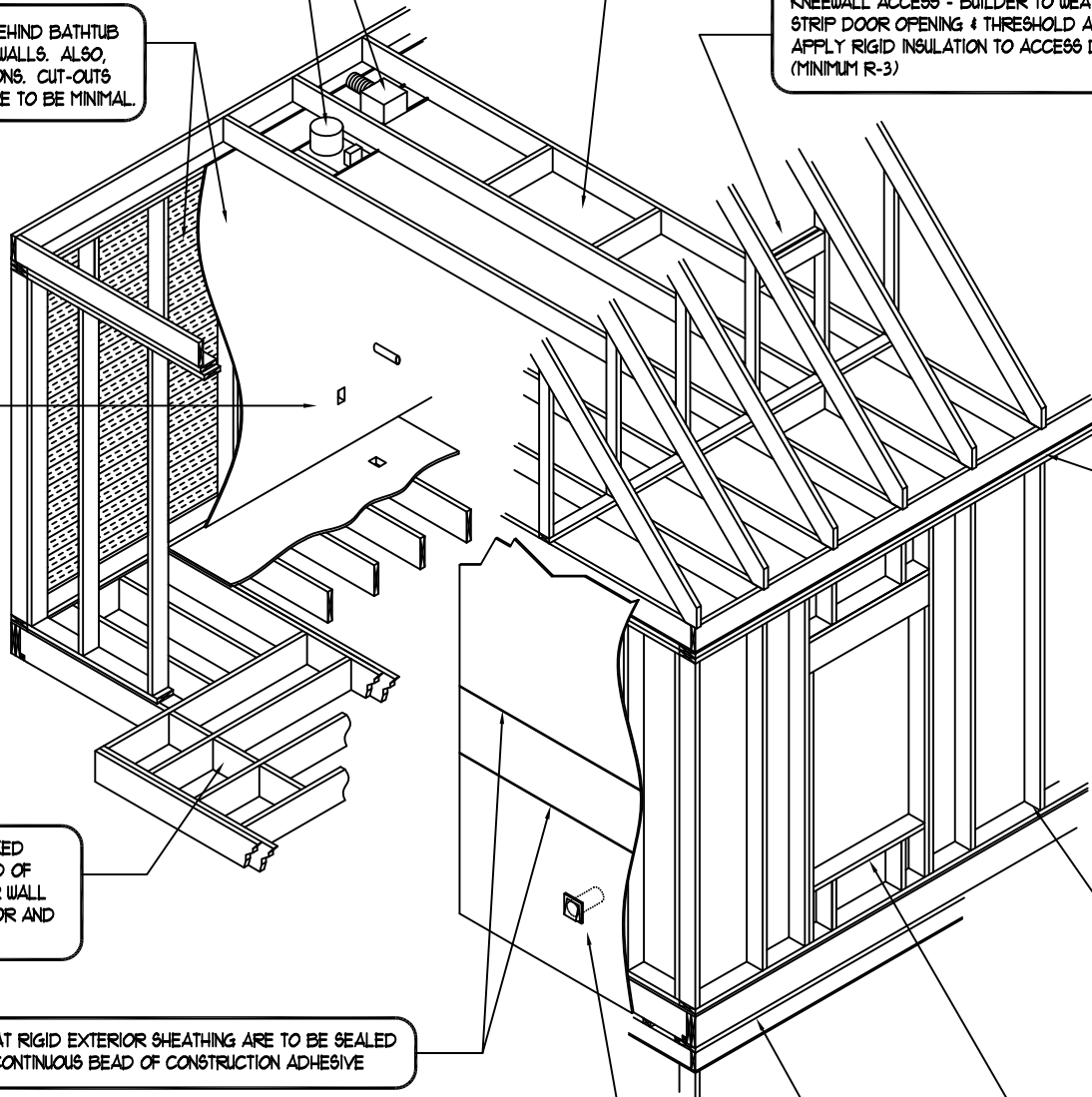
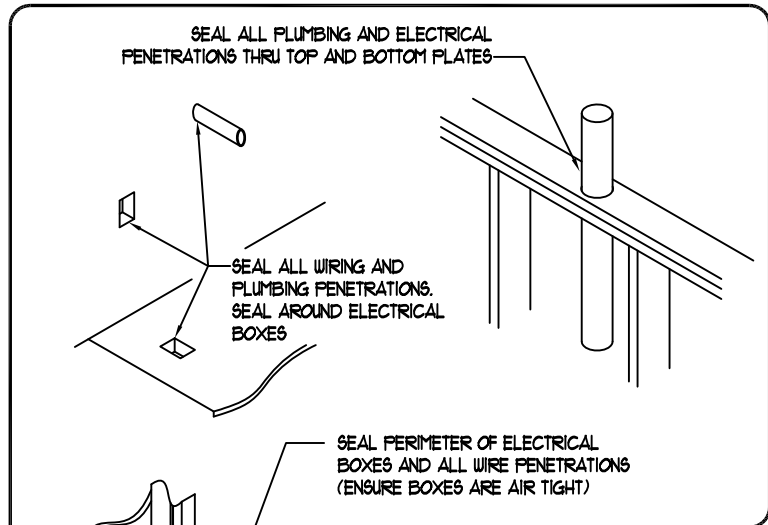

CANTILEVER AREAS ARE TO BE BLOCKED AND SEALED. APPLY CONTINUOUS BEAD OF CONSTRUCTION ADHESIVE AT EXTERIOR WALL LINE PRIOR TO SETTING WALLS ON FLOOR AND ROOF ON WALLS

SEAMS AT RIGID EXTERIOR SHEATHING ARE TO BE SEALED WITH A CONTINUOUS BEAD OF CONSTRUCTION ADHESIVE

EXTERIOR WALL EXHAUST/VENT TERMINATIONS ARE TO BE SEALED

IT IS THE RESPONSIBILITY OF THE PURCHASER TO INSTALL LOOSE FILL INSULATION (MIN. 2" THICK) OR SPRAY FOAM AT MATING WALL GAPS.

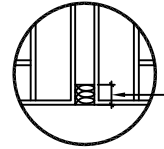

SEAL ALL CRANE CABLE NOTCHES WITH FOAM

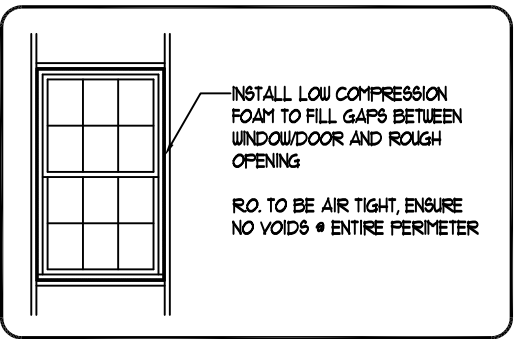
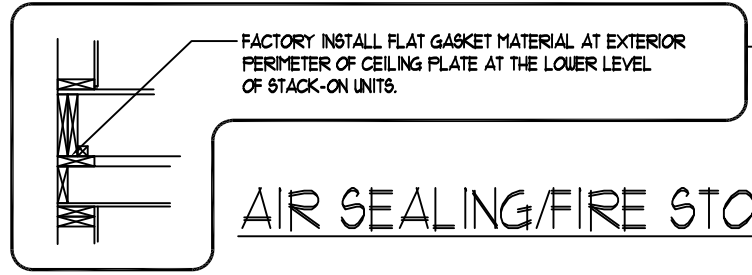

AIR SEALING/FIRE STOP DETAIL SHEET

N.T.S.

PURCHASER: JOB NO.:	CONTRACT NO.:	CHK. BY:	CHK. BY:	FLORIDA REG. NO. 242019 JXM14	FLORIDA REG. DATE 10/28/21
PLAN NAME:	COLLECTION SERIES:	DESIGN DATE:	REV. DATE:	REV. DATE:	REV. DATE:
1000 RIVES ROAD, MARTINSVILLE, VA 24112	(716) 632-1000	FAX (716) 632-1001	WWW.NATIONWIDECUSTOMHOMES.COM	NATIONWIDE Custom Made Easy © COPYRIGHT 2018 NATIONWIDE HOMES ALL RIGHTS RESERVED	
NOTE: ONLY ONE HOUSE MAY BE BUILT UTILIZING THE PLANS THAT ARE DESIGNATED FOR THIS CONTRACT JOB					
PAGE NO.:	13 of 52				

APPROVED BY

 3/7/2024
 Approval of this document does not authorize or approve any deviation or deviations from the requirements of applicable State Laws.
 Kip Whitehead

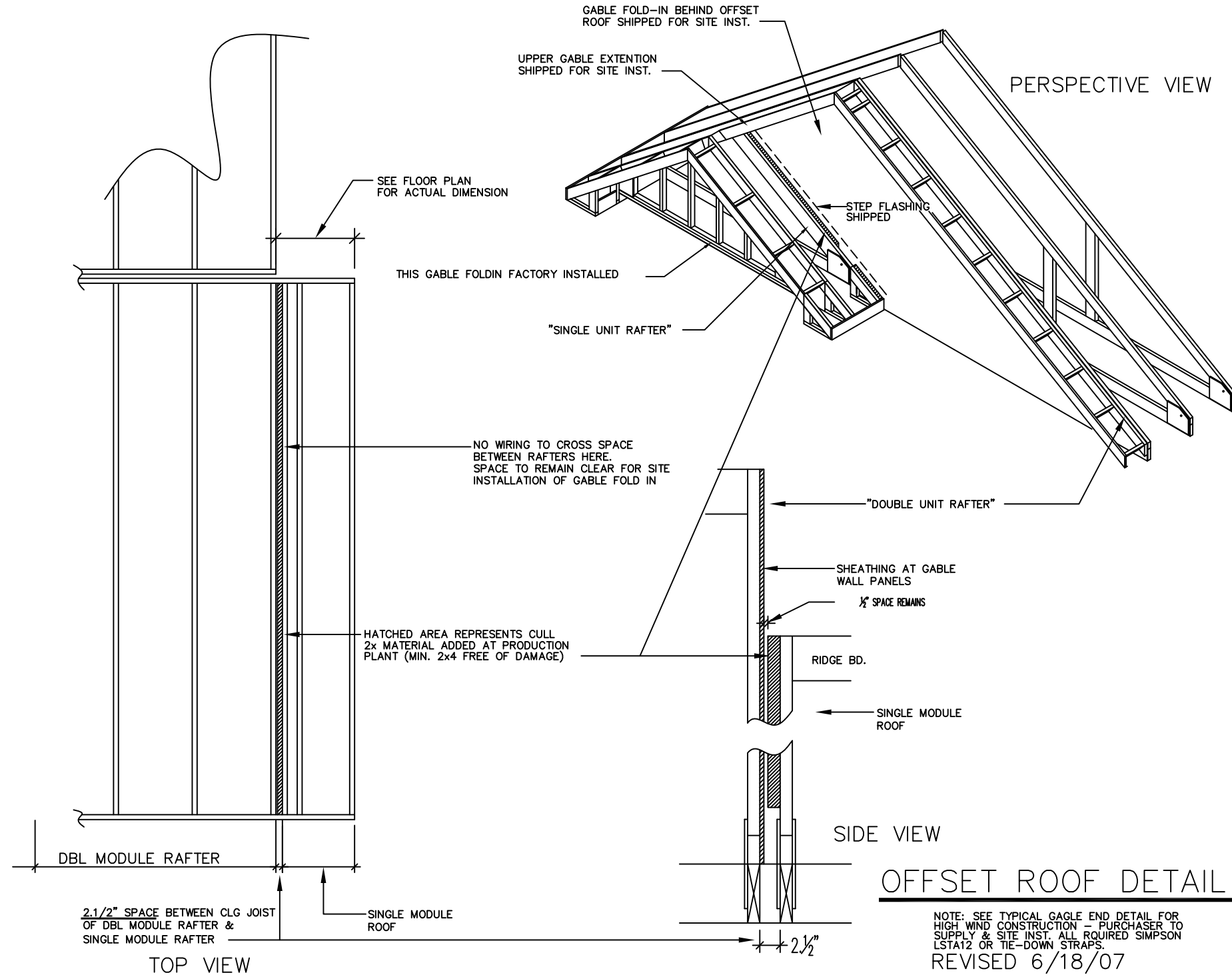

PURCHASER:		CONTRACT NO.:	
JOB NO.:	PROCESS DATE:	DWG. BY:	CHK. BY:
PLAN REVISION DATE: 3.5.2024 BK01	PRODUCTION DATE:	REV. BY:	PLOTTED: 3/5/2024 11:05 AM
PLAN NAME:	COLLECTION/SERIES:	DWG. BY:	CHK. BY:
DESIGN DATE:	REV. DATE:	REV. BY:	REV. BY:
MAGGIE HOUSE FARM (BUICE) 1100 RIVES ROAD, WASHINGTON, VA 24112 (773) 687-1100 FAX (773) 632-1181 WWW.PALMTRUCK.COM © COPYRIGHT 2023 PALM TRUCK HOMES ALL RIGHTS RESERVED			
NOTE: ONLY ONE HOUSE MAY BE BUILT UTILIZING THE PLANS THAT ARE DESIGNATED FOR THIS CONTRACT JOB			
DRAWING NO.:		PAGE NO.:	
14 of 52		52	

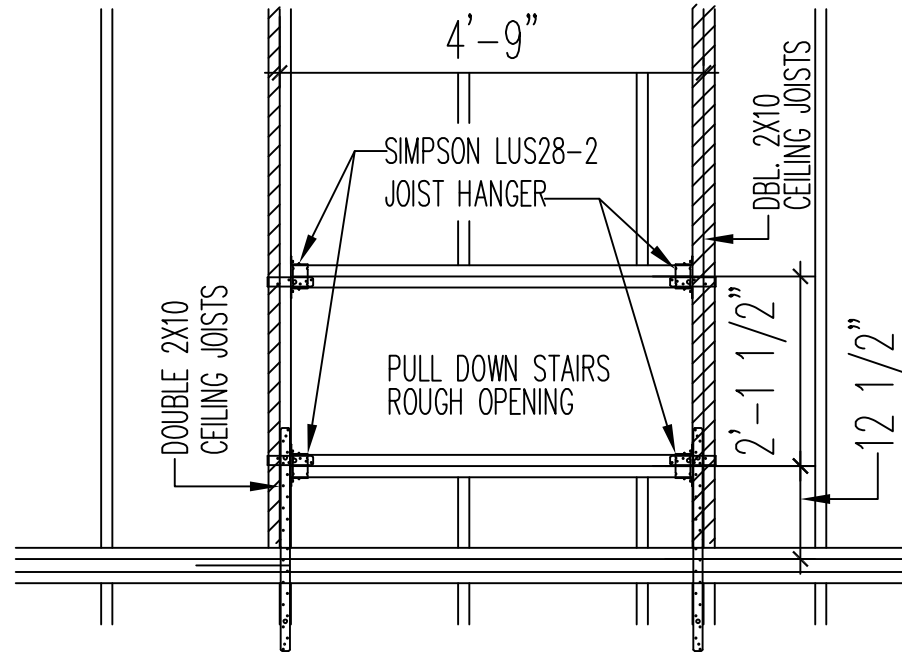

SIMPSON LUS28-2FACE MOUNTED HANGER FASTENING:

HEADER: (6) 16d NAILS

JOISTS: (4) 16d NAILS

DOUBLE 2X10 CEILING JOISTS NAILED W/(2) ROWS OF 16d NAILS AT 16" O/C

DOUBLE 2X10 HEADER NAILED W/(2) ROWS OF 16d NAILS AT 16" O/C

APPROVED BY
NIA 3/7/2024
Approval of this document does not authorize or approve any deviation or deviations from the requirements of applicable State Laws.
Kip Whitehead

BOTTOM CHORD TO STAIR BEAM:

USE (7) 16d NAILS THRU BEAM INTO CHORD ENDGRAIN

TENSION CONNECTION:

USE (15) 16d NAILS THRU SHEATHING INTO CUT BOTTOM CHORD

USE (2) ROWS OF 16d NAILS THRU SHEATHING INTO STAIR BEAM AT 3" O/C

USE (1) SIMPSON LSTA30 ATTACHED TO EACH NARROW FACE OF BOTTOM WRAPPED AROUND STAIR BEAM

STAIR BEAM AT ENDS:

UPLIFT CONNECTION: SIMPSON LUS28-2

TENSION CONNECTION:

USE (18) 16d NAILS THRU SHEATHING INTO BOTTOM CHORD SCAB

PLUS

USE (1) SIMPSON MSTA30 ATTACHED TO SCAB ACROSS MATING LINE

BOTTOM CHORD TO MATING WALL BEAM:

USE (13) 16d NAILS THRU BEAM INTO CHORD ENDGRAIN

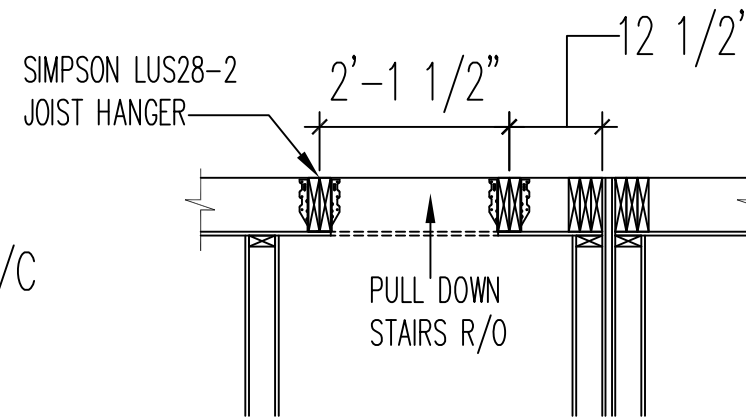

SIDE VIEW

PULL DOWN STAIRS ROUGH OPENING
PERPENDICULAR TO CEILING JOIST DETAIL

PORCH BEAM SPECIFICATIONS:
SEE FLOOR PLAN FOR BEAM SIZE

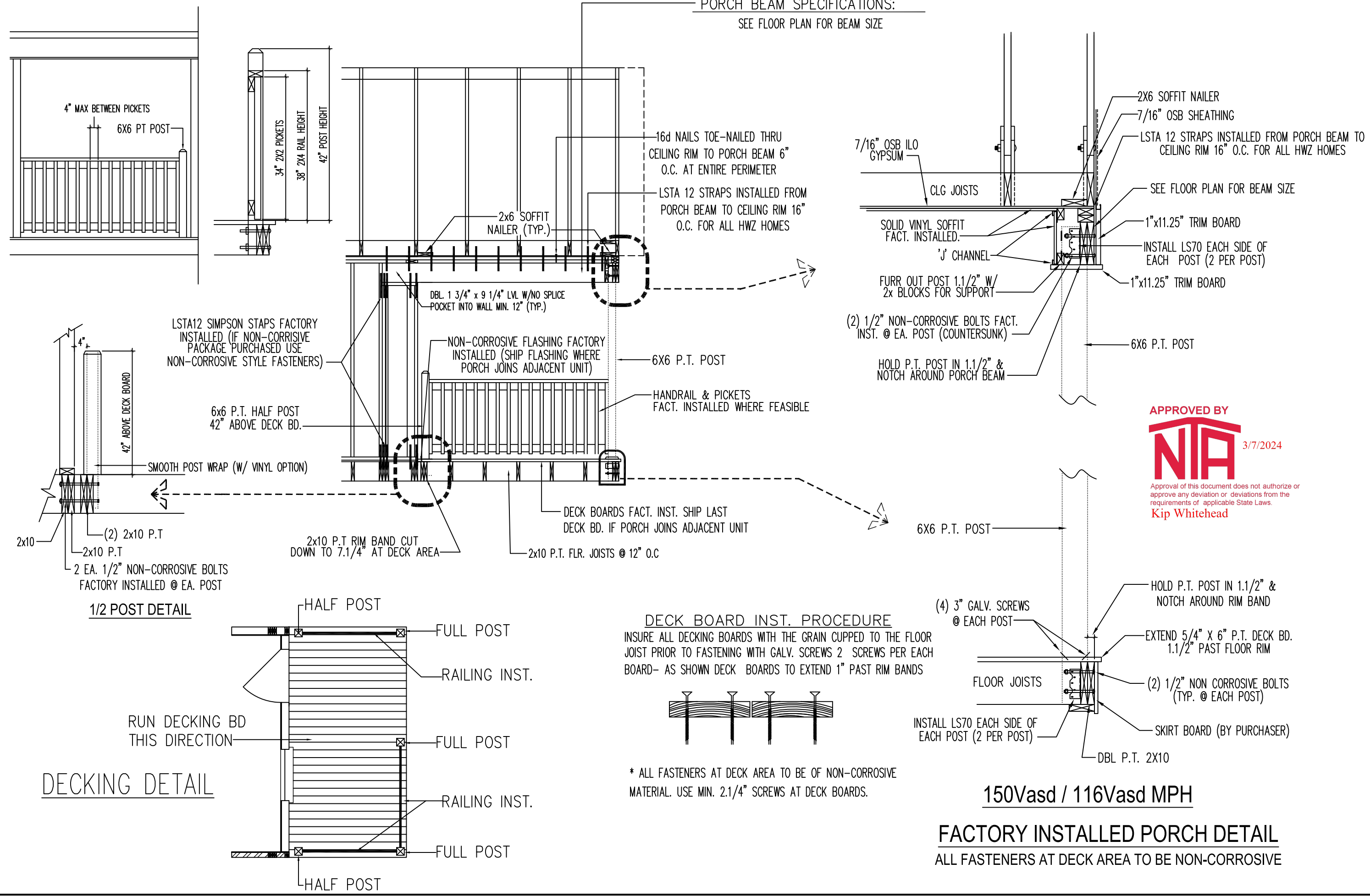

APPROVED BY
NIA 3/7/2024
Approval of this document does not authorize or approve any deviation or deviations from the requirements of applicable State Laws.
Kip Whitehead

150Vasd / 116Vasd MPH
FACTORY INSTALLED PORCH DETAIL
ALL FASTENERS AT DECK AREA TO BE NON-CORROSIVE

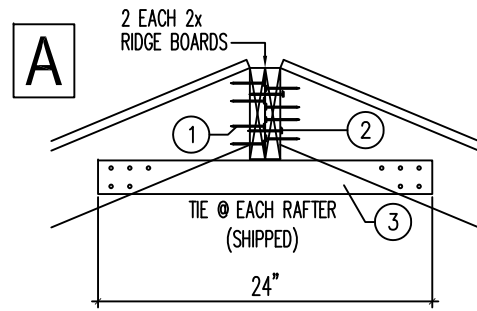

RIDGE BEAM

- (FACT. INST.) TOP CHORD TO RIDGE (V): (4) 16d NAILS INTO END GRAIN OF EACH RAFTER
- (SITE) RIDGE TO RIDGE (V): USE 16d NAILS AT 12" O/C
- (SITE) TOP CHORD AT RIDGE: (TENSION): (5) 10d NAILS THRU EACH END OF A 7/16" x 5.1/2" x 24" OSB TIE (ALT. MEMBERS: 1x4 LUMBER / 2x4 LUMBER)

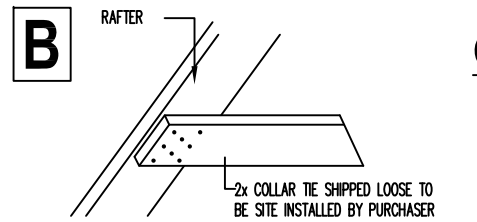

COLLAR TIES TO RAFTER

COLLAR TIE: USE MIN. (14) 16d NAILS EACH END TO CONNECT COLLAR TIE TO RAFTER (SITE INSTALLATION)

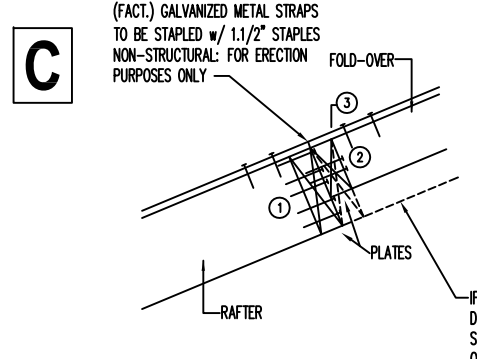

(FACT.) GALVANIZED METAL STRAPS TO BE STAPLED w/ 1.1/2" STAPLES NON-STRUCTURAL: FOR ERECTION PURPOSES ONLY

TOP VIEW

IF FOLD-OVER MEMBER IS THE SAME DEPTH AS THE RAFTER, THEN THE SIMPSON STRAP CAN BE INSTALLED ON THE ATTIC SIDE OF THE FRAMING

RAFTER TO FOLD-OVER & FOLD-OVER TO FOLD-OVER

115Vult - 130Vult:

- FLIP TO TOP CHORD: (SHEAR) - (FACTORY INSTALLED) (6) 16d NAILS THRU PLATES INTO TOP CHORDS

PLUS

- PLATE TO PLATE: (SITE) 16d NAILS @ 6" O.C. THRU PLATES
- TOP CHORD TO PLATE: (TENSION) - (SITE INST.) USE (3) 10d NAILS EA. SIDE OF FLIP

PLUS

USE SIMPSON LSTA18 STRAP WITH (14) 10d NAILS TOTAL TO ATTACH STRAP TO ROOF

(7) 10d NAILS EACH END OF STRAP

SHIPPED FOR SITE INSTALLATION

150 Vult:

- FLIP TO TOP CHORD: (SHEAR) (7) 16d NAILS THRU PLATES INTO TOP CHORDS (FACTORY INSTALLED)

PLUS

- PLATE TO PLATE: 16d NAILS @ 6" O/C THRU PLATES (SITE INSTALLED)
- TOP CHORD TO PLATE: (TENSION) USE (3) 10d NAILS EA. SIDE OF FLIP (SITE INSTALLED)

PLUS

USE SIMPSON LSTA30 STRAP WITH (22) 10d NAILS TOTAL TO ATTACH STRAP TO ROOF (11) 10d NAILS EACH END OF STRAP *** (SHIPPED FOR SITE INSTALLATION) ***

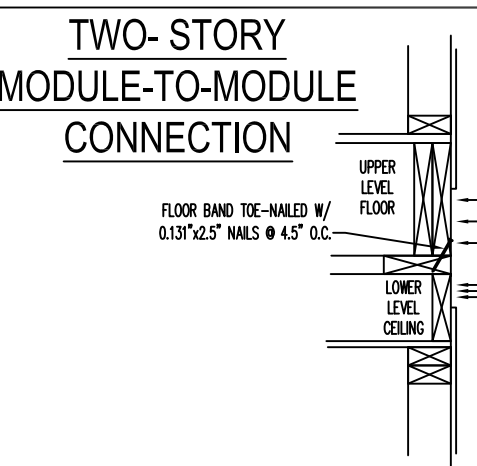

TWO-STORY MODULE-TO-MODULE CONNECTION

FLOOR BAND TOE-NAILED W/ 0.131"x2.5" NAILS @ 4.5" O.C.

FASTEN SITE OSB STRIP PER THE FOLLOWING QTY. & SPACING INTO U.L. FLOOR BAND & L.L. CLG. BAND:

- TRUSSES @ 24" O.C.:
 - 115Vult/89Vasd MPH OR LESS= 3 EA 8d 12" O.C.
 - 150Vult/116 Vasd MPH= 7 EA 8d 4" O.C.
- TRUSSES @ 19.2" O.C.:
 - 115VULT/89VASD MPH OR LESS= 3 EA 8D 9" O.C.
 - 150VULT/116 VASD MPH= 7 EA 8D 3" O.C.
- TRUSSES @ 16" O.C.:
 - 115VULT/89VASD MPH OR LESS= 3 EA 8D 8" O.C.
 - 150VULT/116 VASD MPH= 7 EA 8D 2" O.C.

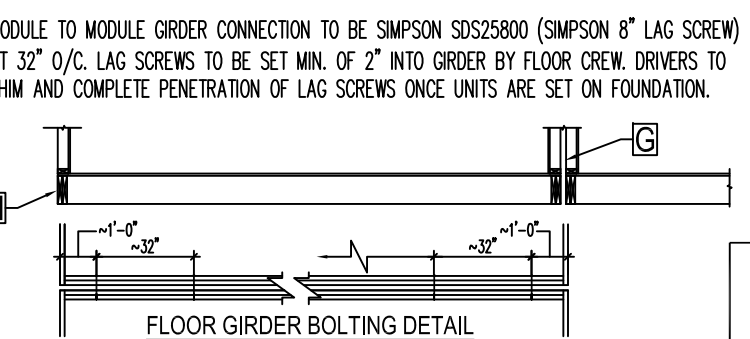
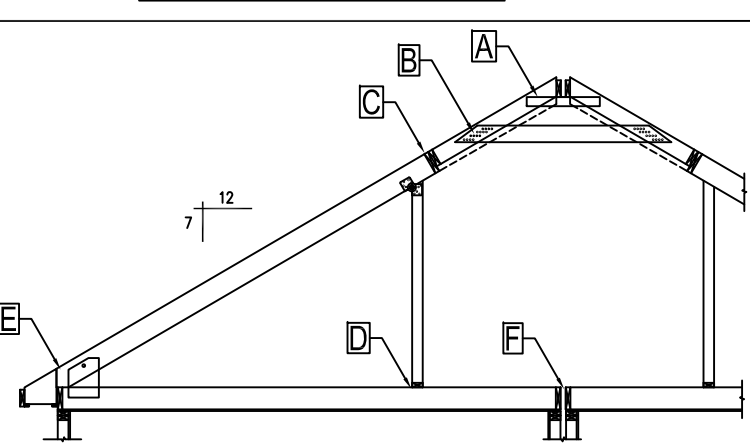
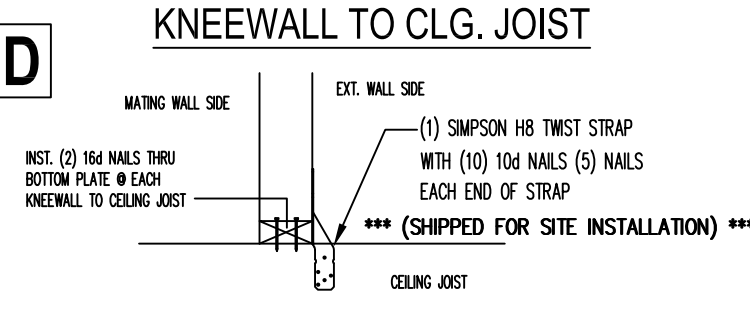

KNEEWALL TO CLG. JOIST

MATING WALL SIDE EXT. WALL SIDE

INST. (2) 16d NAILS THRU BOTTOM PLATE @ EACH KNEEWALL TO CEILING JOIST

(1) SIMPSON H8 TWIST STRAP WITH (10) 10d NAILS (5) NAILS EACH END OF STRAP

*** (SHIPPED FOR SITE INSTALLATION) ***

CEILING JOIST

MODULE TO MODULE GIRDER CONNECTION TO BE SIMPSON SDS25800 (SIMPSON 8" LAG SCREW) AT 32" O/C. LAG SCREWS TO BE SET MIN. OF 1-1/2" INTO CLG. RIM BY ROOF CREW. DRIVERS TO SHIM AND COMPLETE PENETRATION OF LAG SCREWS ONCE UNITS ARE SET ON FOUNDATION.

MODULE TO MODULE GIRDER CONNECTION TO BE SIMPSON SDS25800 (SIMPSON 8" LAG SCREW) AT 32" O/C. LAG SCREWS TO BE SET MIN. OF 2" INTO GIRDER BY FLOOR CREW. DRIVERS TO SHIM AND COMPLETE PENETRATION OF LAG SCREWS ONCE UNITS ARE SET ON FOUNDATION.

FLOOR GIRDER BOLTING DETAIL

APPROVED BY

3/7/2024

Approval of this document does not authorize or approve any deviation or deviations from the requirements of applicable State Laws.

Kip Whitehead

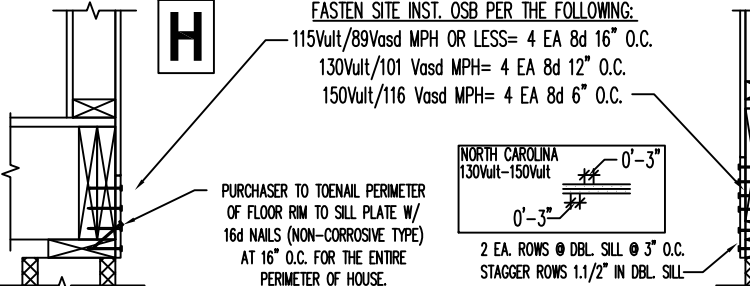

FASTEN SITE INST. OSB PER THE FOLLOWING:

- 115Vult/89Vasd MPH OR LESS= 4 EA 8d 16" O.C.
- 130Vult/101 Vasd MPH= 4 EA 8d 12" O.C.
- 150Vult/116 Vasd MPH= 4 EA 8d 6" O.C.

PURCHASER TO TOENAIL PERIMETER OF FLOOR RIM TO SILL PLATE W/ 16d NAILS (NON-CORROSIVE TYPE) AT 16" O.C. FOR THE ENTIRE PERIMETER OF HOUSE.

NORTH CAROLINA 130Vult-150Vult

2 EA. ROWS @ DBL. SILL @ 3" O.C. STAGGER ROWS 1.1/2" IN DBL. SILL

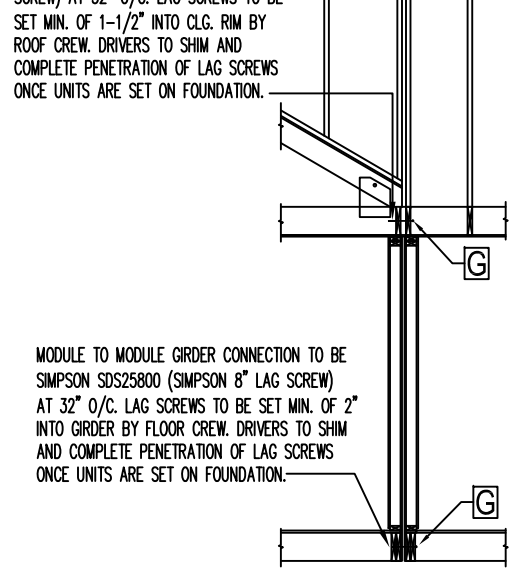

OVERHANG SECUREMENT

WIND SPEED	REQUIRED SPACING FOR STRAPS
115 & 120	EACH END & 8'-0" O.C.
130 & 150	EACH END & 48" O.C.

2x4x10" BLOCK NAILED TO SIDE OF OVERHANG BLOCKS w/4 EA. 10d NAILS

SIMPSON LSTA12 STRAP (1.1/2"x12"x20 ga.) w/ 10 EA. 10d NAILS, 5 EACH END & FACTORY INSTALLED SEE CHART FOR SPACING

PURCHASER TO EXTEND FACTORY INSTALLED STRAP DOWN FOR NAILING INTO CEILING RIM BAND & DBL. TOP PLATES w/5 EA. 10d NAILS

NOTE: ABOVE 2x4 SCAB BLOCK REQUIRED FOR STRAP NAILING THAT IS NOT ALLOWED TO BE NAILED INTO THE END GRAIN AT OVERHANG BLOCKS. IF END GRAIN IS NOT FACING INWARD TOWARD EXTERIOR WALL, THEN THE STRAP CAN BE NAILED DIRECTLY TO OVERHANG BLOCK.

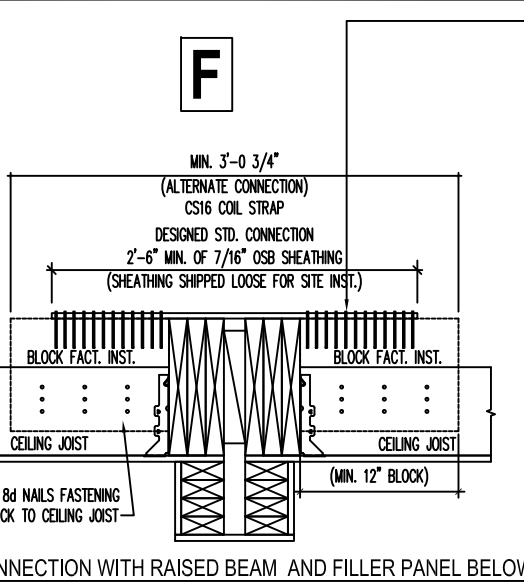

MATING WALL TENSION CONNECTION

MIN. 3'-0 3/4" (ALTERNATE CONNECTION) CS16 COIL STRAP DESIGNED STD. CONNECTION 2'-6" MIN. OF 7/16" OSB SHEATHING (SHEATHING SHIPPED LOOSE FOR SITE INST.)

CEILING JOIST

(9) 8d NAILS FASTENING BLOCK TO CEILING JOIST

CONNECTION WITH RAISED BEAM AND FILLER PANEL BELOW

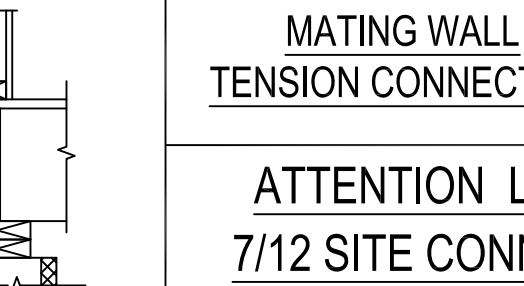

7/16" OSB SHEATHING SHIPPED FOR SITE INSTALLATION BY PURCHASER ACROSS MATING WALLS w (12) 10d (0.148" x 3") NAILS PER SIDE

STD. MATING WALLS w/ CEILING JOIST SECUREMENT IN ATTIC

OR

STRAP FLUSH CEILING WITH RAISED BEAM

REQUIRED FOR DRAFTSTOPPING

TYPICAL RAISED BEAM

CEILING JOIST

BOLT BEAM IF SPAN 10FT AND OVER (TYP.)

SIMPSON LSTA-30 STRAP (SHIPPED) & SITE INSTALLED BY PURCHASER AT BOTTOM OF CLG. JOISTS w/ 22 EA. 10d NAILS, 11 EA. END

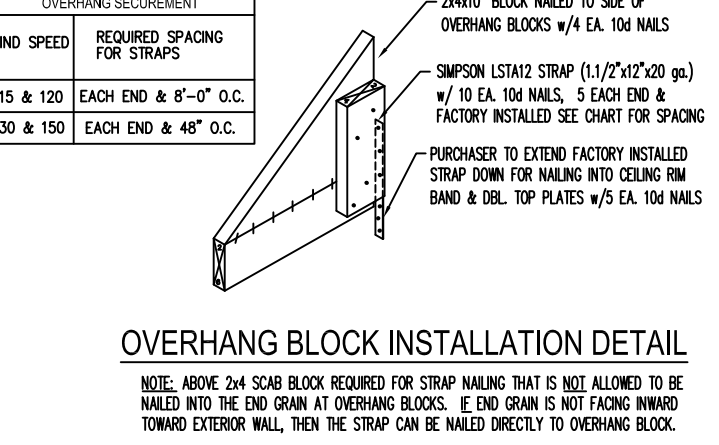

ATTENTION LOCAL INSPECTION DEPARTMENT

7/12 SITE CONNECTIONS - SET UP INSTRUCTIONS

7/12 SITE CONNECTIONS - SET UP INSTRUCTIONS

FASTENING SCHEDULE: (115-120 Vult) *** FACTORY INSTALLED ***
(A) ROOF SHEATHING TO GABLE END RAFTER: 16ga. STAPLES 1.3/4" LONG 3" EDGE / 6" FIELD
(B) ROOF SHEATHING TO O/S GABLE EXTENSION: 16ga. STAPLES 1.3/4" LONG AT 3" O.C.
(C) 2X6 O/S GABLE EXTENSION TO 2X6 LADDER BLOCK: MIN. (2) 16d NAILS EACH END
(D) 2X6 I/S GABLE EXTENSION TO GABLE END RAFTER: MIN. (2) 16d NAILS AT 12" O.C.

FASTENING SCHEDULE: (130 Vult AND GREATER) *** FACTORY INSTALLED ***
(A) ROOF SHEATHING TO GABLE END RAFTER: 8d NAILS AT 4" O.C.
(B) ROOF SHEATHING TO O/S GABLE EXTENSION: 8d NAILS AT 6" O.C.
(C) 2X6 O/S GABLE EXTENSION TO 2X6 LADDER BLOCK: MIN. (2) 16d NAILS EACH END
(D) 2X6 I/S GABLE EXTENSION TO GABLE END RAFTER: MIN. (2) 16d NAILS AT 12" O.C.

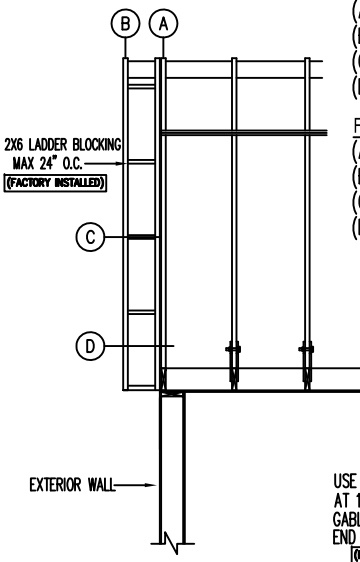

GABLE EXTENSION CONNECTION
ALL WIND ZONES

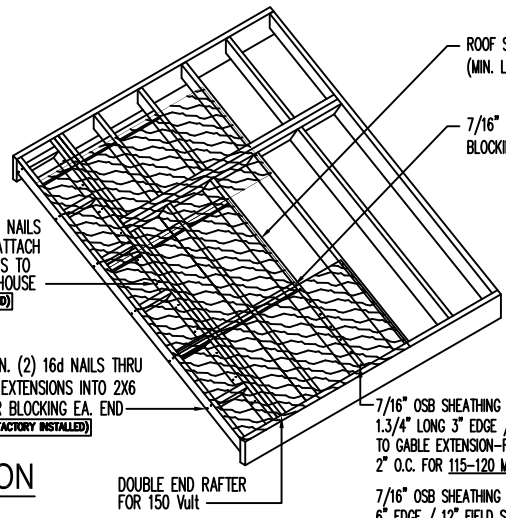

FACTORY CONNECTIONS

USE MIN. (2) 16d NAILS AT 12" O.C. TO ATTACH GABLE EXTENSIONS TO END RAFTER OF HOUSE (FACTORY INSTALLED)

USE MIN. (2) 16d NAILS THRU GABLE EXTENSIONS INTO 2X6 LADDER BLOCKING EA. END (FACTORY INSTALLED)

ROOF SHEATHING JOINTS NOT LESS THAN 24" FROM GABLE END WALL (MIN. LENGTH OF PANEL: 48" | 60" W/ GABLE END EXTENSION)

7/16" OSB PANEL EDGES FASTENED TO BLOCKING W/ 8d NAILS @ 6" O.C. (TYPICAL)

7/16" OSB SHEATHING FASTEN TO RAFTERS WITH 16ga. STAPLES 1.3/4" LONG 3" EDGE / 6" FIELD SPACING EXCEPT FOR END RAFTER TO GABLE EXTENSION-FASTEN WITH 16ga. STAPLES 1.3/4" LONG AT 2" O.C. FOR 115-120 MPH *** FACTORY INSTALLED ***

7/16" OSB SHEATHING FASTEN TO RAFTERS WITH 8d NAILS 6" EDGE / 12" FIELD SPACING EXCEPT FOR END RAFTER TO GABLE EXTENSION-FASTEN WITH 8d NAILS AT 4" O.C. FOR 130-150Vult *** FACTORY INSTALLED ***

2x4 BLOCKING MIN. 2 BAYS/CAVITIES (FACTORY INST.)

USE MIN. (2) 16d NAILS THRU GABLE EXTENSIONS INTO 2X6 LADDER BLOCKING EA. END (FACTORY INSTALLED)

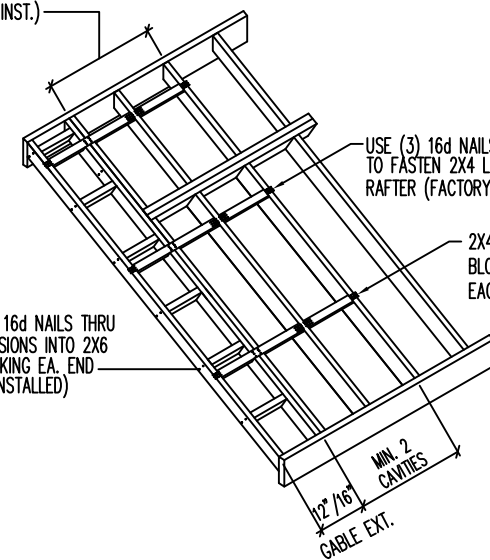

FACTORY CONNECTIONS

(2) 0.137"x3" NAILS @ 12" O.C.

24" O.C. MAX

12" OR 16" GABLE EXTENSION CONNECTION DETAIL

** 140 Vult AND GREATER **

NON-CORROSIVE FASTENERS & STRAPS TO BE USED AS REQUIRED BY LOCAL BUILDING JURISDICTION. PURCHASER RESPONSIBLE FOR STRAPS NOT NOTED AS INSTALLED BY NATIONWIDE HOMES

ATTENTION LOCAL INSPECTION DEPARTMENT

*** (ALTERNATIVE CONNECTION ONLY) ***

THIS CONNECTION WOULD BE IN LIEU OF THE GABLE EXTENSION CONNECTIONS ABOVE

2x6 COLLAR TIE (SHOWN DASHED) IS SHIPPED FOR SITE INSTALLATION AT EACH RAFTER BY THE PURCHASER SEE SITE CONNECTION DETAILS FOR FASTENING REQUIREMENTS

2x6x12' HORIZONTAL CROSS BRACE SHIPPED FOR EA. GABLE END (SITE INSTALLED @ INSIDE OF GABLE FOLD-IN WALL)

(4) 2x4x10' ANGLE BRACES SHIPPED FOR SITE INSTALLATION (REFER TO CROSS SECTION OF GABLE BRACING) BUILDER TO CUT ANGLE ON EACH END OF BRACE ON SITE (THIS MATERIAL WILL BE ADDED TO PACKING LIST)

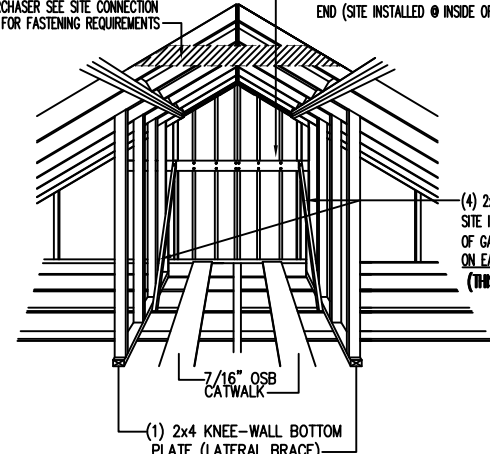

INTERIOR GABLE FOLD-IN BRACING

FOR 4/12, 5/12, 6/12, 7/12, 8/12 ROOF PITCHES AND 9/12 DECORATIVE ROOF PITCH

*** 140 Vult AND GREATER ***

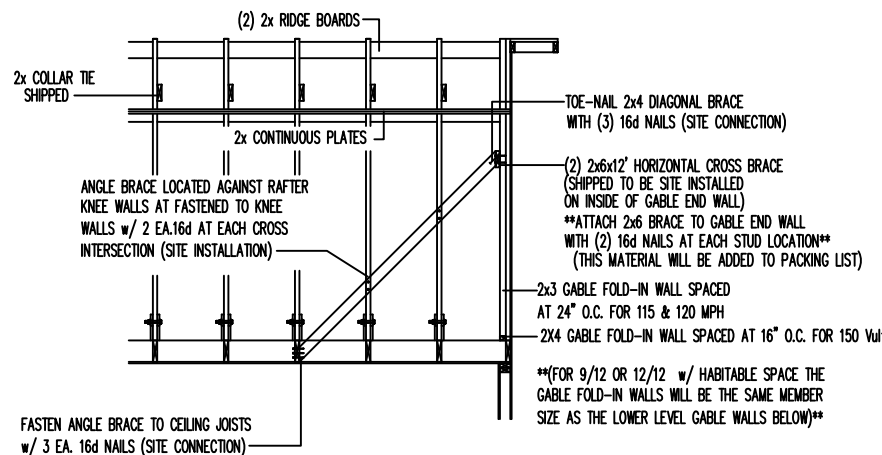

CROSS SECTION OF GABLE BRACING

FOR 4/12, 5/12, 6/12, 7/12, 8/12 ROOF PITCHES AND 9/12 DECORATIVE ROOF PITCH

ALL CONSTRUCTION AND FASTENING OF GABLE FOLD-IN BRACING IS PRESCRIPTIVE PER THE 2018 NORTH CAROLINA RESIDENTIAL CODE - CHAPTER 45.

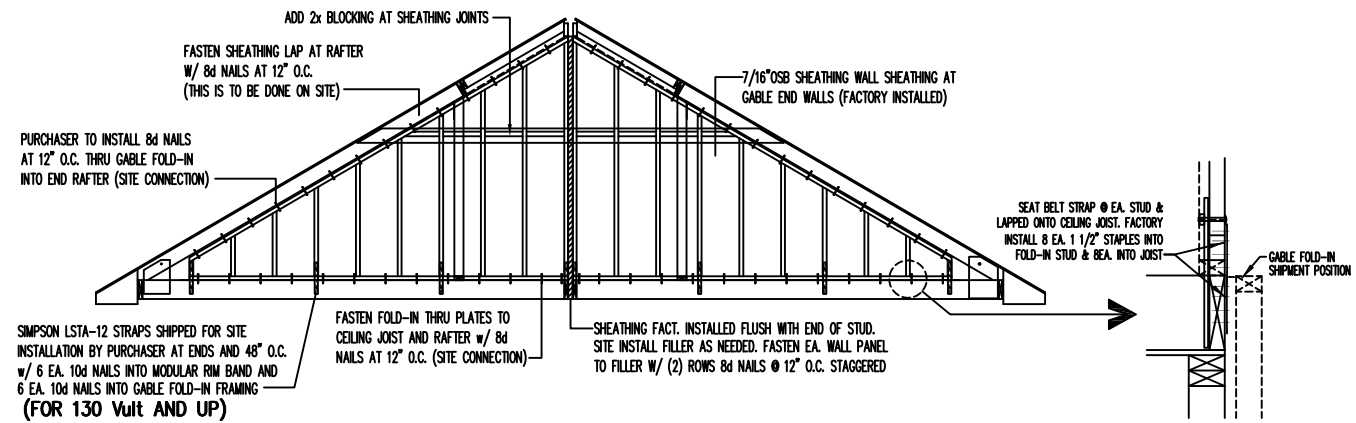

UP TO 120 Vult WIND ZONES:

PURCHASER TO FASTEN GABLE FOLD-IN PANEL AS FOLLOWS:

1. FASTEN SHEATHING LAP @ RAFTER WITH 8d NAILS SPACED AT 6" EDGE / 12" FIELD (IF APPLICABLE)
2. FASTEN GABLE FOLD-IN THRU PLATES TO CLG. JOIST AND RAFTER W/ 8d NAILS @ 12" O.C.
3. SHEATHING INSTALLED TO END STUD. BUILDER TO SITE INST. 2x FILLERS AS NEEDED.
4. FASTENING FOR 7/16" OSB SHEATHING: 8d NAILS SPACED AT 6" EDGE / 12" FIELD
5. GABLE FOLD-IN WALL SPACING PER CONSTRUCTION DETAIL ** (FOR 12/12 ROOFS W/ LIVING SPACE GABLE FOLD-IN WALL WILL BE THE SAME AS THE LOWER LEVEL GABLE WALL)**

130 Vult, AND GREATER, WIND ZONES:

PURCHASER TO FASTEN GABLE FOLD-IN PANEL AS FOLLOWS:

- ** (BLOCKING INSTALLED AT SHEATHING JOINTS)**
1. FASTEN SHEATHING LAP @ RAFTER W/ 8d NAILS @ 12" O.C. (IF APPLICABLE)
 2. FASTEN GABLE FOLD-IN THRU PLATES TO CLG. JOIST AND RAFTER W/ 16d NAILS @ 12" O.C.
 3. SHEATHING INSTALLED TO END STUD. BUILDER TO SITE INST. 2x FILLERS AS NEEDED.
 4. FASTENING FOR 7/16" OSB SHEATHING: 8d NAILS SPACED AT 3" O.C. EDGE / 6" O.C. FIELD
 5. GABLE FOLD-IN WALL SPACING: 2x4 AT 16" O.C.
5.1. (FOR 12/12 ROOFS W/ LIVING SPACE GABLE FOLD-IN WALL WILL BE THE SAME AS THE LOWER LEVEL GABLE WALL)

GABLE END WALL CONNECTION DETAIL

115 - 150 Vult HOUSES

ATTENTION LOCAL INSPECTION DEPARTMENT

7/12 SITE CONNECTIONS - SET UP INSTRUCTIONS

WINDOW HEADER UPLIFT CONNECTIONS

FASTENING OPTIONS (EACH SIDE OF OPENING LINE):

- **STANDARD WIND:**
 - UP TO 36.5" OPENING
 - (4) 16ga.
 - ALTERNATE CONNECTION: (1) LSTA12
 - UP TO 75.5" OPENING
 - (8) 16ga.
 - ALTERNATE CONNECTION: (1) LSTA12

- **HIGH WIND ZONE:**
 - UP TO 36.5" OPENING
 - (9) 8d NAILS EACH SIDE OF OPENING LINE
 - ALTERNATE CONNECTION: (2) LSTA12
 - UP TO 75.5" OPENING
 - (19) 8d NAILS EACH SIDE OF OPENING LINE
 - ALTERNATE CONNECTION: (3) LSTA12

= CONNECTION ZONES

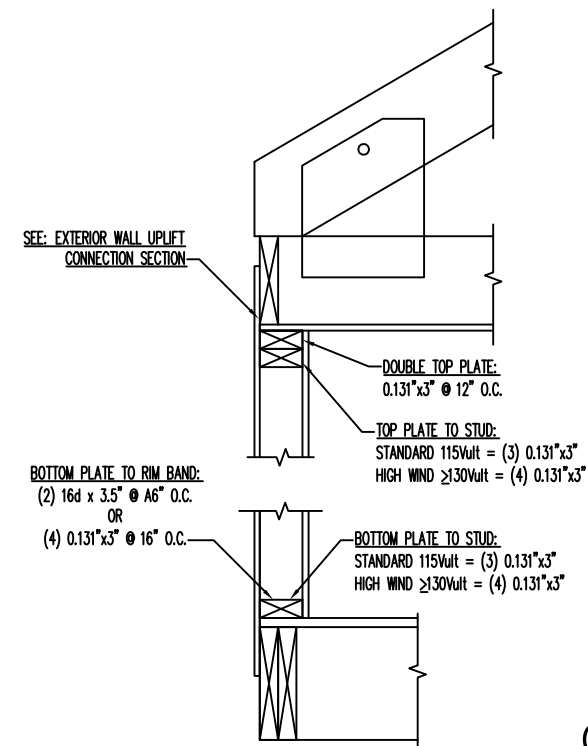
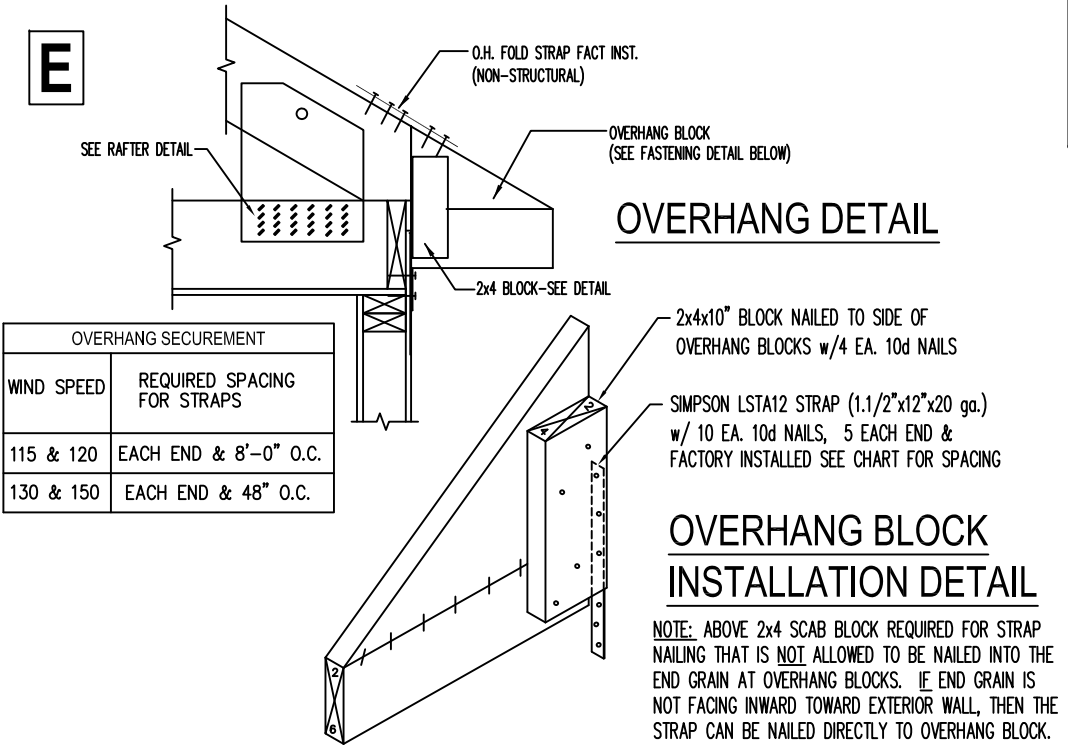
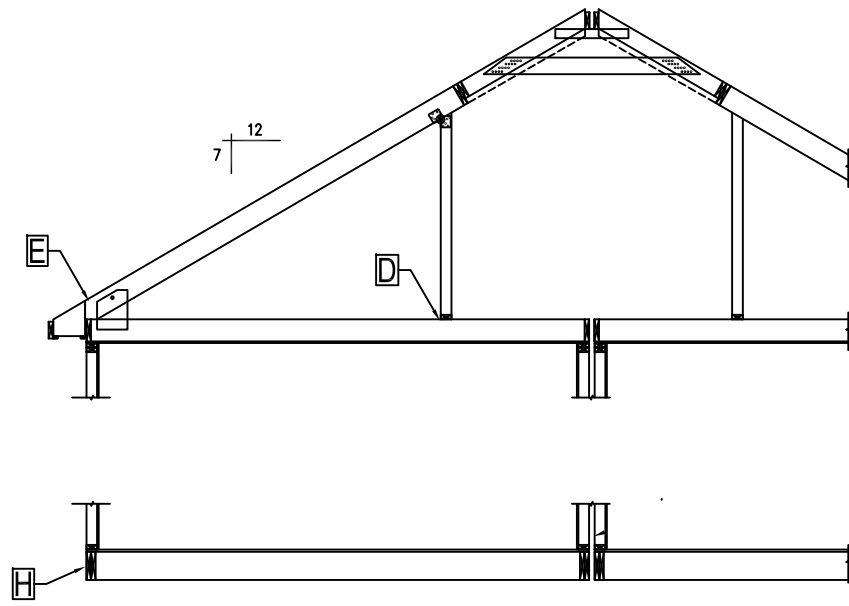
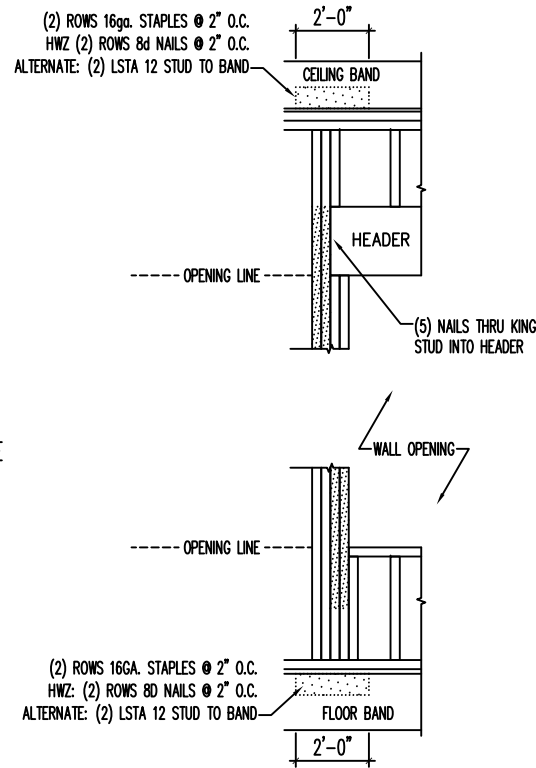

EXTERIOR WALL STUD CONNECTIONS

APPROVED BY

 3/7/2024
 Approval of this document does not authorize or approve any deviation or deviations from the requirements of applicable State Laws.
 Kip Whitehead

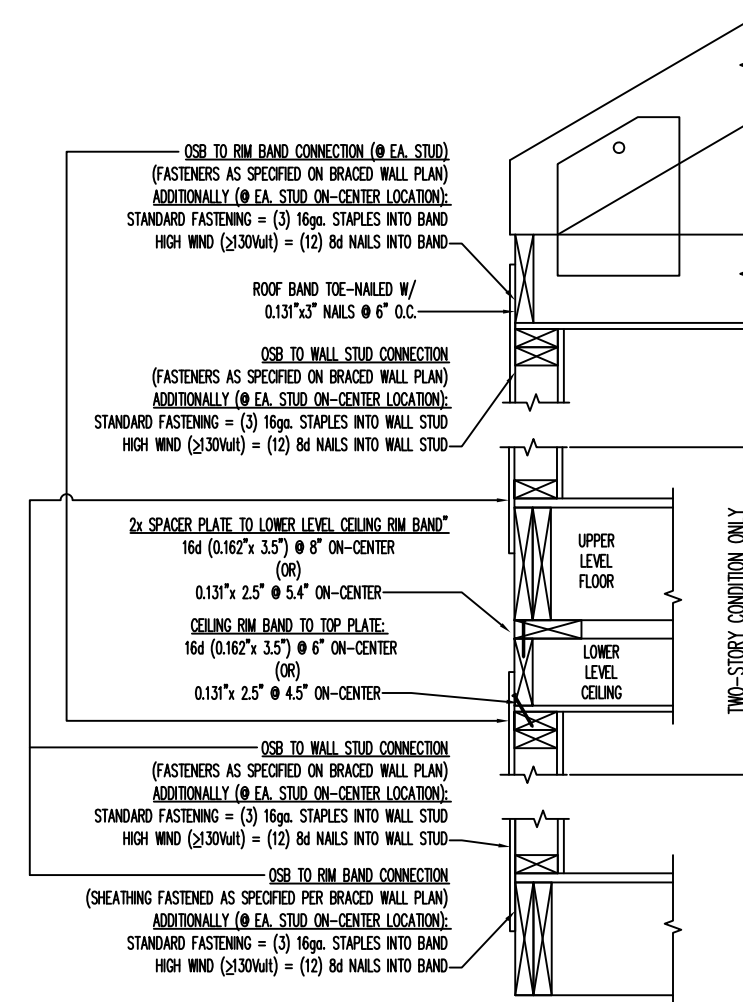
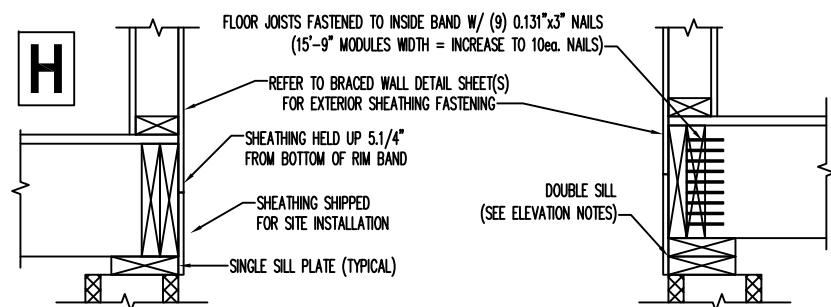

EXTERIOR WALL UPLIFT

FACTORY INSTALLED COMPONENTS/FASTENERS

7/12 CONNECTIONS



1100 RIES ROAD, MARTINSVILLE, VA 24112
 (276) 632-7100
 WWW.NATIONWIDECUSTOMHOMES.COM

NOTE: ONLY ONE HOUSE MAY BE BUILT UTILIZING THE PLANS THAT ARE DESIGNATED FOR THIS CONTRACT JOB

PURCHASER:
 JOB NO.:
 BLACKLINE DATE & BY:
 PLAN REVISION DATE: 1/19/2024 BXK01

CONTRACT NO.:
 PROCESS DATE & BY:
 PLOTTED: 1/26/2024 1:35 PM

PLAN NAME: 7/28 SITE CONNECTIONS

COLLECTION/SERIES:
 © COPYRIGHT 2024 NATIONWIDE HOMES
 ALL RIGHTS RESERVED

PAGE NO.

19 of 52

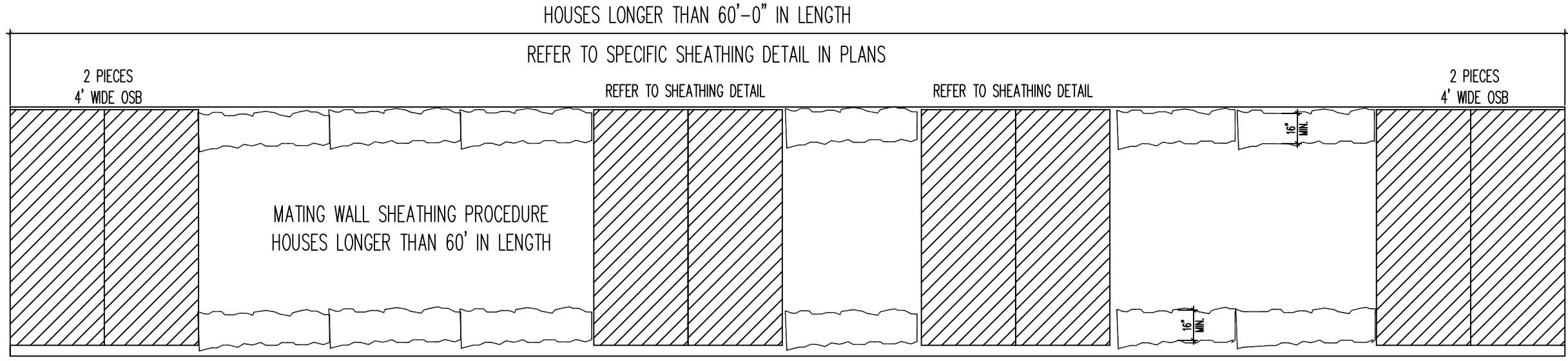
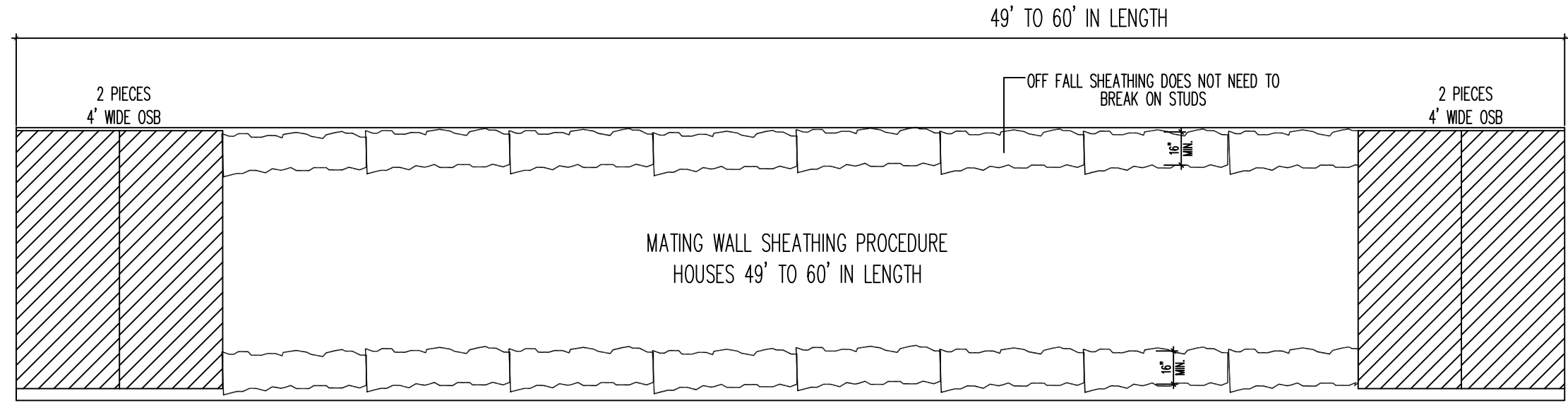
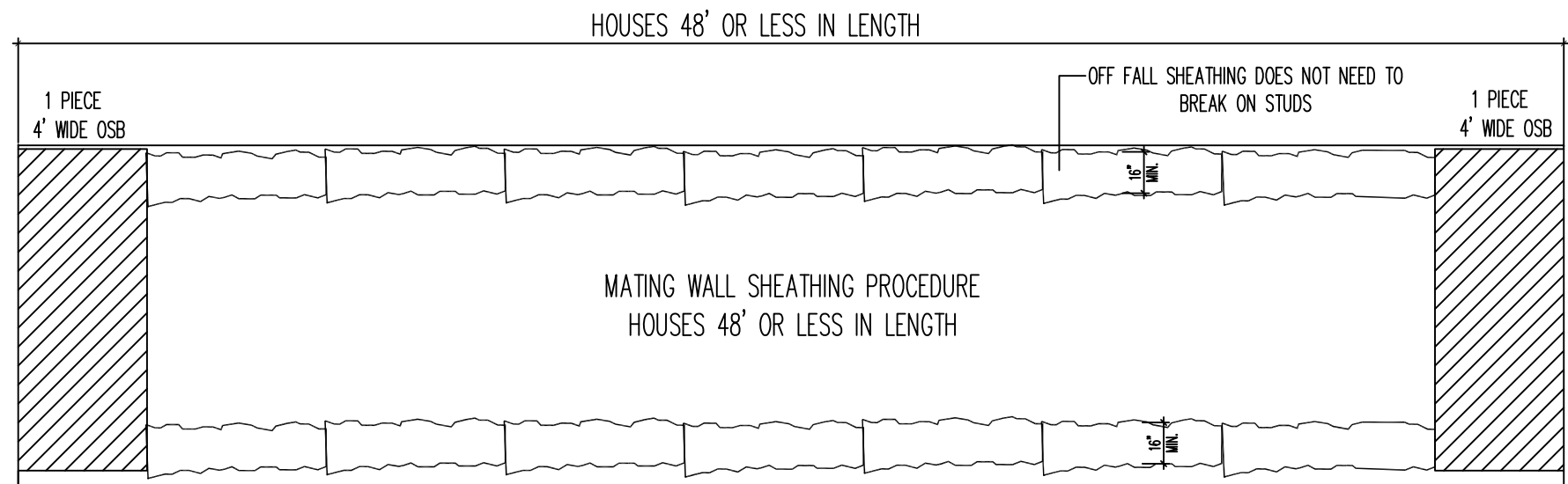
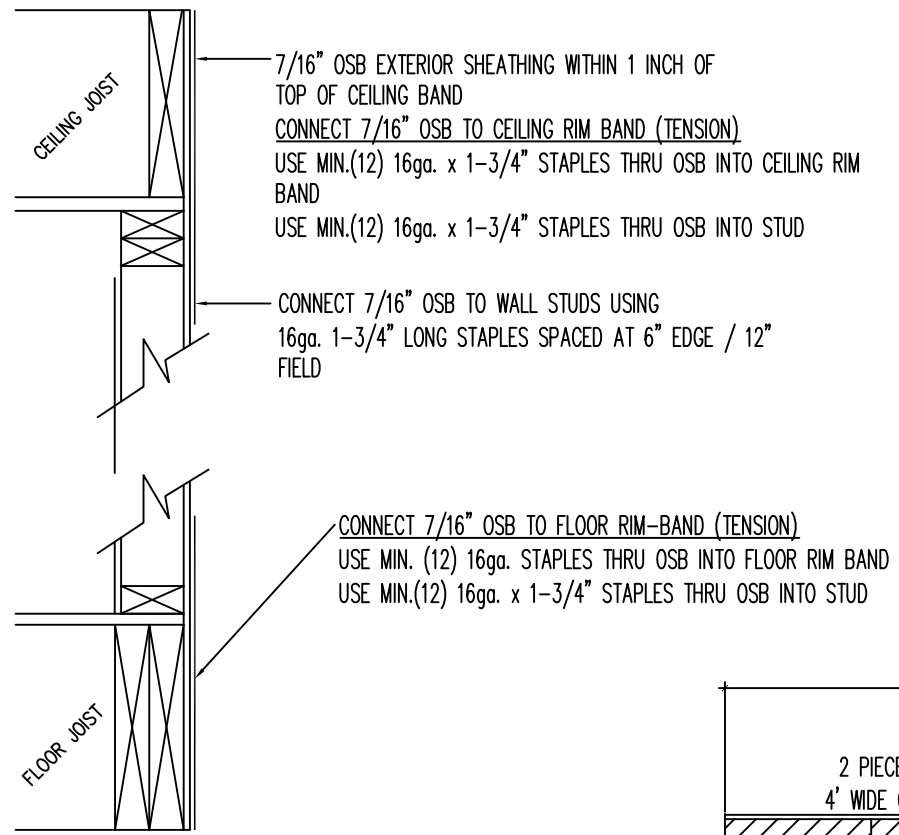

MATING WALL TO CEILING/ FLOOR JOIST SHEATHING APPLICATION/CONNECTION DETAIL

APPROVED BY

 3/7/2024
 Approval of this document does not authorize or approve any deviation or deviations from the requirements of applicable State Laws.
 Kip Whitehead

NO.	DESCRIPTION
ALL WIND SPEEDS SHOWN BELOW IN MPH ARE 3-SECOND GUST	
1	DBL. 2x6 RIDGE BOARDS (#2 SPF OR EQUAL)
2	SHINGLES (SITE INSTALLED AT O.H. & U.I. FOLD-OVER)
3	2x FOLD-OVER RAFTERS (#2 SPF OR EQ.) (115WULT/150WULT) REFER TO ROOF FRAMING FOR SPACING
4	SYNTHETIC UNDERLAYMENT
5	2x COLLAR TIE (SITE-INSTALLED) #2 SYP OR EQUAL (REFER TO ROOF FRAMING FOR SPACING)
6	2x RAFTERS #2 SYP OR EQ. (115WULT / 150WULT) (REFER TO ROOF FRAMING FOR SPACING)
7	ROOF SHEATHING (115WULT / 150WULT) 7/16" OSB SHEATHING
8	2x4 KNEEWALL (#2 SPF OR EQ.) (115WULT / 150WULT) (REFER TO ROOF FRAMING FOR SPACING)
9	KNEEWALL HINGE
10	2x8 CEILING JOISTS (#2 SYP OR EQUAL) (REFER TO ROOF FRAMING FOR SPACING)
11	OSB GUSSETS AT EACH SIDE
12	BOLT ASSEMBLY
13	CONTINUOUS PERIMETER BAND (#2 SYP OR EQUAL)
14	FASCIA BOARD
15	VINYL CONTINUOUS VENTED SOFFIT
16	7/16" OSB STRUCTURAL SHEATHING (115WULT / 150WULT)
17	VINYL EXTERIOR SIDING
18	DOUBLE PERIMETER BAND 2x10 (#2 SYP OR EQUAL)
19	MIN. 2x6 PRESSURE TREATED SILL PLATE W/ANCHOR BOLTS
20	FOUNDATION WALL AND CONCRETE FOOTER
21	1/2" GYPSUM WALL BOARD
22	R-15 WALL INSULATION (R-19 or R-21 W/ 2x6 OPTION)
23	EXT. WALL STUDS: 2x4 AT 16" O/C (2x6 OPTION) #2 SPF OR EQUAL
24	3/4" OSB T&G FLOOR SHEATHING
25	MATING WALL STUDS: 2x3 AT 16" O/C (#2 SPF OR EQUAL) 115WULT / 150WULT
26	MATING WALL SHEATHING: 7/16" OSB STRUCTURAL SHEATHING
27	R-19 FLR INSULATION SITE INSTALLED BY PURCHASER (OPT. R-30 FACT. INSTALLED)
28	BASEMOULD
29	SIMPSON SDS25800 (SIMPSON 8" LAG SCREW) AT 32" O.C
30	CONCRETE PIERS
31	CONCRETE FOOTER
32	STRUCTURAL SUPPORT COLUMN
33	CONCRETE SLAB FLOOR
34	GRAVEL AND VAPOR BARRIER
35	EARTH
36	EXPANSION JOINT
37	FOUNDATION WALL
38	DRAIN TILE WITH GRAVEL SURROUND
39	SOLID CAPE (IF REQUIRED)
40	TERMITE SHIELD
41	DAMP PROOFING
42	INSULATION BAFFLE- SITE INSTALLED BY PURCHASER
43	CONTINUOUS DOUBLE 2x AT FOLD-OVER (#2 SPF OR EQUAL)
44	DOUBLE 2x4 TOP PLATE (SPF STUD GRADE OR EQUAL)
45	2x10 FLOOR JOISTS AT 16" O.C (#2 SYP OR EQUAL)
46	1/2" CEILING GYPSUM
47	DOUBLE 2x10 GIRDER EACH SIDE (#2 SYP OR EQUAL)
48	R-38 CLG. INSULATION FACTORY INSTALLED
49	WEATHER RESISTIVE BARRIER
50	7/16" OSB COMPRESSION STRIP (ENTIRE LENGTH OF LOAD BEARING WALL)
51	2x FIRESTOP INSTALLED BY PURCHASER (#2 SYP OR EQUAL)

GENERAL NOTES:

- ALL CONSTRUCTION BELOW BOTTOM OF FLOOR JOIST RESPONSIBILITY OF SITE CONTRACTOR. ALL INFORMATION SHOWN BELOW BOTTOM OF FLOOR JOIST IS SUGGESTIVE ONLY. REFER TO STATE AND LOCAL CODES FOR ACTUAL CONSTRUCTION METHOD REQUIRED.
- REFER TO FOUNDATION WALL SECTION ON FOUNDATION PLAN FOR UNITS BEING CONSTRUCTED IN AREAS GREATER THAN 115 mph WULT WIND ZONE.
- REFER TO FOUNDATION PLAN FOR LOCATION OF PIERS/COLUMNS.
- CONSTRUCTION OF BASEMENT STAIRS BY PURCHASER.
- MIN. 18" FROM GRADE FOR WOOD JOISTS AND 12" MIN. FOR WOOD GIRDERS.
- MIN. 6" FROM GRADE TO EXTERIOR SIDING.
- PURCHASER TO REFER TO BUILDER RESPONSIBILITY BULLETIN INSTRUCTIONS FOR ERECTION COMPLETION REQUIREMENTS.
- FOUNDATION SECTION IS SUGGESTIVE ONLY. ALL FOUNDATION CONSTRUCTION IS THE RESPONSIBILITY OF THE BUILDER. CONSTRUCTION SHALL CONFORM TO CURRENT STATE BUILDING CODES, SUBJECT TO INSPECTION BY LOCAL JURISDICTION.
- PURCHASER RESPONSIBLE FOR SECURING MODULAR UNITS TO FOUNDATION AND MODULAR TO MODULAR UNITS. FOR HIGH WIND AREAS: CONNECTION MATERIAL AND ENGINEERING IS THE RESPONSIBILITY OF THE PURCHASER.
- ALL PILING FOUNDATIONS SHALL BE ENGINEERED BY PURCHASER.
- SEE FOUNDATION PLAN AND "SUPERIOR WALL" DETAILS WHEN A "SUPERIOR WALL" FOUNDATION SYSTEM IS USED.
- ALL MATERIALS LISTED ABOVE REPRESENTS NATIONWIDE HOMES STANDARD CONSTRUCTION. ALTERNATE MATERIALS FOR CONSTRUCTION MAY BE REQUESTED BY THE CUSTOMER AS SUBSTITUTION FOR STANDARD MATERIALS. THESE ITEMS WILL BE NOTED ON THE PRODUCTION ORDER AND/OR PLANS, AND NOT ON THIS CROSS SECTION.
- FOR WIND ZONES 150 mph WULT AND ABOVE: HORIZONTAL MID SPAN BLOCKING AT EXTERIOR WALLS AT SHEATHING JOINTS (IF HORIZONTAL INSTALLATION)
- REFER TO COVER SHEET FOR WIND ZONE SPEED.

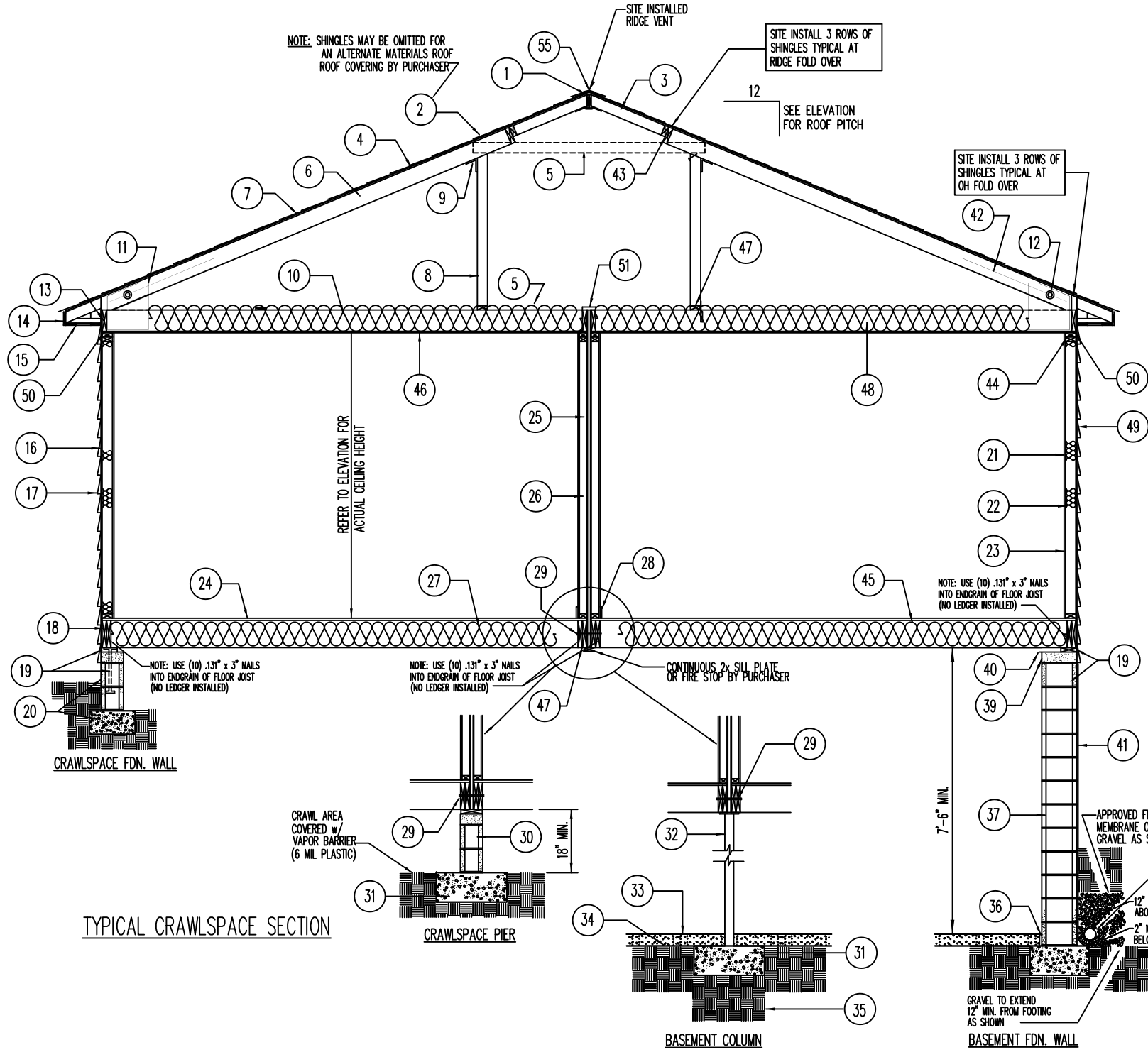

TYPICAL CRAWLSPACE SECTION

TYPICAL BASEMENT SECTION

RANCH CROSS SECTION

APPROVED BY

 3/7/2024
 Approval of this document does not authorize or approve any deviation or deviations from the requirements of applicable State Laws.
Kip Whitehead

FOR ROOF TRUSS REFERENCE - 7/12 (13'-9") SEE NATIONWIDE HOMES CALCULATIONS MANUAL, SECTION #8, PAGES 15, 22, 23 & 24

FOR ROOF TRUSS REFERENCE - 7/12 (15'-9") SEE NATIONWIDE HOMES CALCULATIONS MANUAL, SECTION #8, PAGES 29, 32, 33 & 42

FOR ROOF TRUSS REFERENCE - 7/12 (29'-8") SEE NATIONWIDE HOMES CALCULATIONS MANUAL, SECTION #8, PAGES 85, 92, 93 & 98

FOR PORCH CONNECTION REFERENCE - 7/12 (13'-9") SEE NATIONWIDE HOMES CALCULATIONS MANUAL, SECTION #8, PAGES 27 & 28

FOR FLOOR JOISTS FASTENING REFERENCE SEE NATIONWIDE HOMES CALCULATIONS MANUAL, SECTION #48, PAGES #3-8

EXTERIOR HEADER SIZED PER - 7/12 RAFTER COMP. LOAD SUMMARY
 **SECTION 36/page.37 (PAGE 2024 OF MANUAL) BASED ON L/360
 (FOR THE FOLLOWING WINDOWS AND EXTERIOR DOORS: 3660 WINDOWS, TWIN 3060 WINDOW, 3036 WINDOW, 3068 FRONT DOOR, AND 3068 SIDE DOOR IN DINING ROOM

KINRO (SERIES 9750) LOW-E

SHGC=0.29		U FACTOR = 0.34						
ACTUAL SIZE		ROUGH OPENING		8% LIGHT (SQ.FT.)		4% VENT. (SQ.FT.)		
PLAN CODE	WIDTH	HEIGHT	WIDTH	HEIGHT	GL. AREA	FLR. AREA	OPEN AREA	FLR. AREA
3036	29 1/2	35 1/2	30 3/4	37	5.55	69.38	2.64	66.00
3036 Tw	60 1/2	35 1/2	61 3/4	37	6.55	81.87	3.64	91.00
3660 "	35 1/2	59 1/2	36 3/4	61	12.21	152.63	5.99	149.75
3660 Tw	72 1/2	59 1/2	73 1/4	61	24.42	305.25	11.98	299.50
3660 Tr	108 3/4	59 1/2	109 1/2	61	25.42	317.75	12.98	324.50
***4646	45 1/2	45 1/2	46 3/4	47	13.03	162.88	-	-

* MIN EGRESS WINDOW @ GRADE LEVEL ***U FACTOR = 0.32 & SHGC = 0.35
** EGRESS WINDOW

EXTERIOR DOORS (SIZES)

PLAN CODE	SIZE		ROUGH OPENING		DESCRIPTION
	WIDTH	HEIGHT	WIDTH	HEIGHT	
3068	3'-0"	6'-8"	38 1/2"	82 1/2"	PRE-HUNG EXTERIOR
3068	3'-0"	6'-8"	51 1/2"	82 1/2"	PRE-HUNG W/ SINGLE SIDELITE
3068	3'-0"	6'-8"	64 1/2"	82 1/2"	PRE-HUNG W/ DOUBLE SIDELITE
6068	6'-0"	6'-8"	75 1/2"	82 1/2"	CENTER HINGED PATIO DOOR
6068	6'-0"	6'-8"	72 1/4"	80"	SLIDING GLASS DOOR - VINYL
3068	3'-0"	6'-8"	38 1/2"	93"	PRE-HUNG W/ TRANSOM
3068	3'-0"	6'-8"	51 1/2"	93"	PRE-HUNG SGL. SIDELITE W/ TRANS.
3068	3'-0"	6'-8"	64 1/2"	93"	PRE-HUNG DBL. SIDELITE W/ TRANS.
6068	6'-0"	6'-8"	75 1/2"	82 1/2"	PRE-HUNG CENTER HINGED PATIO
6068	6'-0"	6'-8"	75 1/2"	82 1/2"	DOUBLE DOORS (BOTH PANELS OPERABLE)

OUTSWING UNITS: REDUCE R.O. HEIGHT 3/4"

KINRO TRANSOMS (LOW-E & ARGON) (SQUARE & ELLIPTICAL)

SHGC=0.35		U FACTOR = 0.28		DP35 STD / DP 50 HWZ		
ACTUAL SIZE		ROUGH OPENING		8% LIGHT (SQ.FT.)		
PLAN CODE	WIDTH	HEIGHT	SINGLE		GL. AREA	FLR. AREA
			W.	H.		
2812	27 1/2	12	28 1/4	12 3/4	5.07	63.39
2828	28 1/2	28 1/2	29 1/4	29 1/4	12.50	156.21
3612	35 1/2	12	36 1/4	12 3/4	6.60	82.44
4812	47 1/2	12	48 1/4	12 3/4	8.88	111.01
6012	59 1/2	12	60 1/4	12 3/4	11.17	139.58
7212	71 1/2	12	72 1/4	12 3/4	13.45	168.15
3036 w/ELIP	29 1/2	48 1/2	30 1/4	49	22.04	275.46

THERMA TRU EXTERIOR DOORS (LIGHT/VENT & THERMAL VALUES)

DOOR NUMBER	GLASS AREA	FLOOR AREA	U-VALUE	SHGC	VENT	FLOOR AREA	DESCRIPTION
S220	-	-	0.20	0.01	19.810	495.25	2 PANEL
S206	5.06	63.25	0.22	0.09	19.810	495.25	1/2 LITE (NO MUNTINS)
S80	6.68	83.50	0.23	0.11	19.810	495.25	2/3 LITE (NO MUNTINS)
S118	9.15	114.38	0.29	0.16	19.810	495.25	FULL-LITE (NO MUNTINS)
S4814	2.33	29.13	0.23	0.09	19.810	495.25	CRAFTSMAN (4-LITE MUTINS)
S262	5.06	63.25	0.22	0.08	19.810	495.25	1/2 LITE 2 PANEL (4-LITE MUNTINS)
S2106	6.68	83.50	0.23	0.10	19.810	495.25	2/3 LITE 2 PANEL (4-LITE MUNTINS)
S1209	9.15	114.38	0.29	0.14	19.810	495.25	FULL-LITE (4-LITE MUNTINS)
214	40.00	500.00	0.31	0.20	19.810	495.25	SLIDING GLASS DOOR
215	40.00	500.00	0.31	0.18	19.810	495.25	SLIDING GLASS DOOR (INT. MUNTINS)
SIDELITES							
S210SL	2.21	27.63	0.18	0.05	-	-	HALF-LITE (NO MUNTINS)
S751SL	2.21	27.60	0.18	0.05	-	-	2/3 LITE (NO MUNTINS)
S100SL	2.59	32.38	0.19	0.05	-	-	FULL-LITE (NO MUNTINS)
S4812SL	.74	9.25	0.22	0.06	-	-	CRAFTSMAN (2-LITE MUNTINS)
S212SL	2.21	27.63	0.18	0.04	-	-	HALF-LITE (2-LITE MUNTINS)
S1089SL	2.45	30.63	0.19	0.04	-	-	2/3 LITE (2-LITE MUNTINS)
S1209SL	2.59	32.38	0.18	0.04	-	-	FULL-LITE (2-LITE MUNTINS)

INTERIOR DOORS

PLAN CODE	SIZE		ROUGH OPENING		DESCRIPTION
	WIDTH	HEIGHT	WIDTH	HEIGHT	
1668	1'-6"	6'-8"	20 1/2"	82 1/2"	PRE-HUNG INTERIOR
2068	2'-0"	6'-8"	26 1/2"	82 1/2"	PRE-HUNG INTERIOR
2468	2'-4"	6'-8"	30 1/2"	82 1/2"	PRE-HUNG INTERIOR
2668	2'-6"	6'-8"	32 1/2"	82 1/2"	PRE-HUNG INTERIOR
2868	2'-8"	6'-8"	34 1/2"	82 1/2"	PRE-HUNG INTERIOR
3068	3'-0"	6'-8"	38 1/2"	82 1/2"	PRE-HUNG INTERIOR
2068	2'-0"	6'-8"	26 1/2"	94 1/2"	PRE-HUNG INTERIOR W/ TRANSOM
2468	2'-4"	6'-8"	30 1/2"	94 1/2"	PRE-HUNG INTERIOR W/ TRANSOM
2668	2'-6"	6'-8"	32 1/2"	94 1/2"	PRE-HUNG INTERIOR W/ TRANSOM
2868	2'-8"	6'-8"	34 1/2"	94 1/2"	PRE-HUNG INTERIOR W/ TRANSOM
3068	3'-0"	6'-8"	38 1/2"	94 1/2"	PRE-HUNG INTERIOR W/ TRANSOM
4068	4'-0"	6'-8"	50 1/2"	94 1/2"	PRE-HUNG INTERIOR W/ TRANSOM
5068	5'-0"	6'-8"	62 1/2"	94 1/2"	PRE-HUNG INTERIOR W/ TRANSOM
6068	6'-0"	6'-8"	74 1/2"	94 1/2"	PRE-HUNG INTERIOR W/ TRANSOM
2068	2'-0"	6'-8"	26 1/2"	82 1/2"	PRE-HUNG INTERIOR BIFOLD
2668	2'-6"	6'-8"	32 1/2"	82 1/2"	PRE-HUNG INTERIOR BIFOLD
3068	3'-0"	6'-8"	38 1/2"	82 1/2"	PRE-HUNG INTERIOR BIFOLD
4068	4'-0"	6'-8"	50 1/2"	82 1/2"	PRE-HUNG INTERIOR BIFOLD
5068	5'-0"	6'-8"	62 1/2"	82 1/2"	PRE-HUNG INTERIOR BIFOLD
1680	1'-6"	8'-0"	20 1/2"	98 1/2"	PRE-HUNG INTERIOR
2080	2'-0"	8'-0"	26 1/2"	98 1/2"	PRE-HUNG INTERIOR
2480	2'-4"	8'-0"	30 1/2"	98 1/2"	PRE-HUNG INTERIOR
2680	2'-6"	8'-0"	32 1/2"	98 1/2"	PRE-HUNG INTERIOR
2880	2'-8"	8'-0"	34 1/2"	98 1/2"	PRE-HUNG INTERIOR
3080	3'-0"	8'-0"	38 1/2"	98 1/2"	PRE-HUNG INTERIOR

TRANSOMS

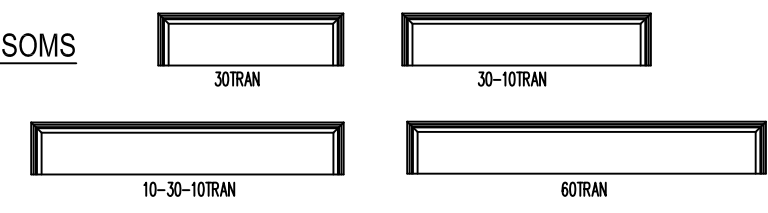

SIDELITES

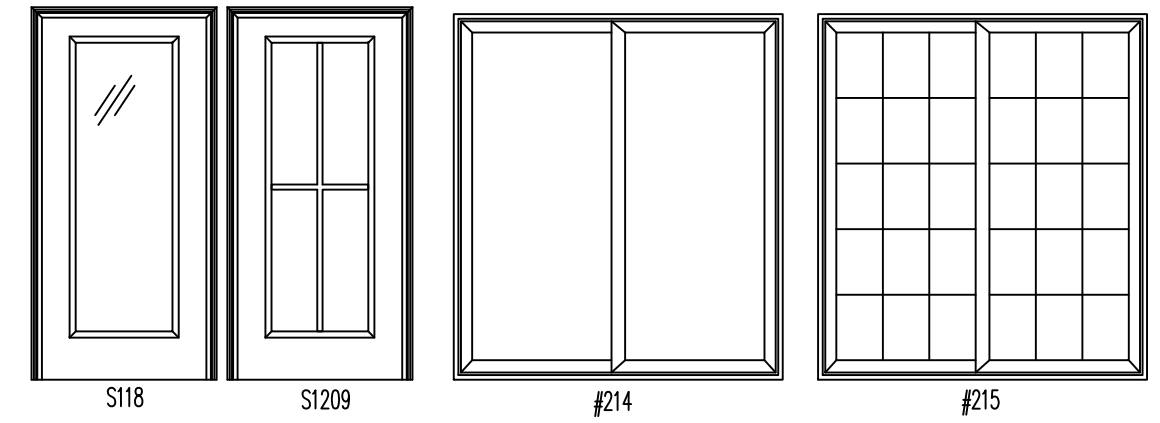
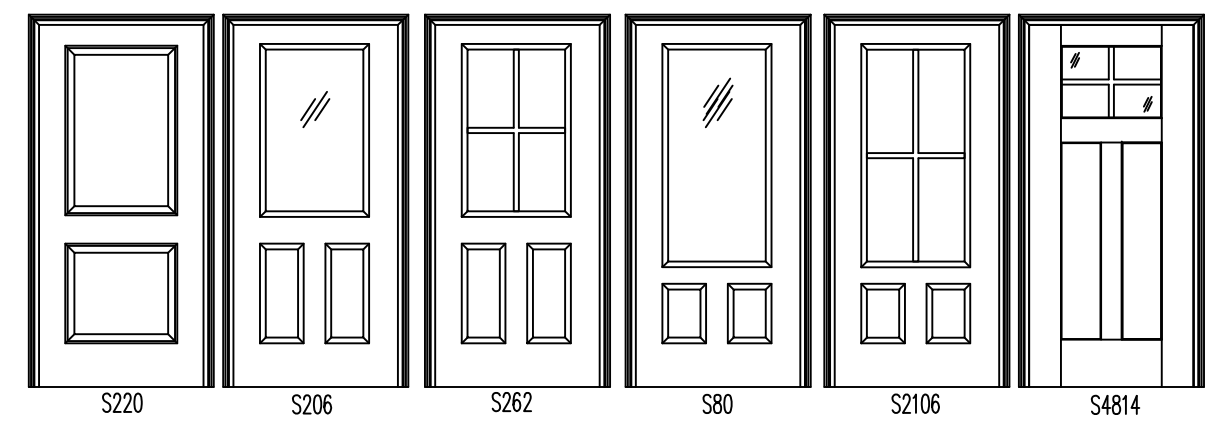
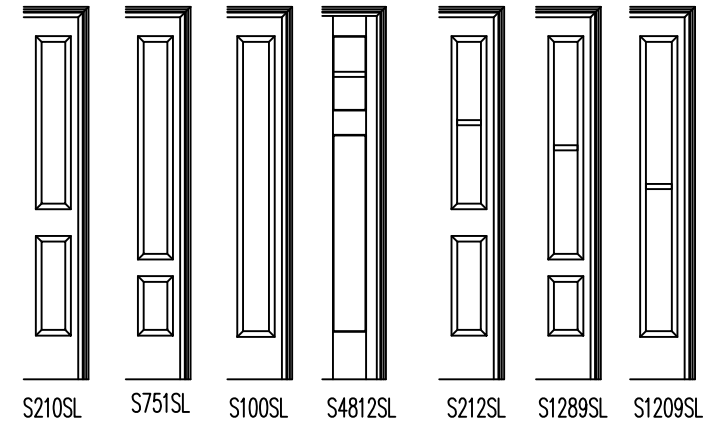

APPROVED BY
NIA 3/7/2024
Approval of this document does not authorize or approve any deviation or deviations from the requirements of applicable State Laws.
Kip Whitehead

EXTERIOR DOORS
* GLASS PATTERNS SHOWN ARE REPRESENTATIVE & MAY VARY BY DESIGN BETWEEN DOOR MANUFACTURERS AND/OR DESIGN PRESSURES

Nationwide Custom Homes Inc.

1100 RIVES ROAD
MARTINSVILLE, VA. 24112
(276) 632-7100

Model Name and Contract No.: #196763 Rescue Construction Clara "C" Model Home / Lot Model

Electrical Load Calculations:

General Lighting Load:	1,615 Sq. Ft. @ 3 volts-amperes/ft2	=	4,845 watts
Small Appliance Load: (3 circuits)		=	4,500 watts
Laundry:		=	1,500 watts

Net Load: 10,845 watts

Range :		=	8,640 watts
Microwave :		=	1,000 watts
Dryer Load:		=	5,600 watts
Dishwasher :		=	1,032 watts
Water Heater: (4500 / 240 * 125%)		=	5,625 watts

Net Load: 32,742 watts

10000 watts @ 100%		=	10,000 watts
32,742	22,742 @ 40%	=	9,097 watts

Net Load: 19,097 watts

Heat Pump - 1st floor (2-1/2 ton) :		=	8,820 watts
		=	

Total Load: 27,917 watts

Calculated Load for Service: 27,917 = 116 Amperes

General Notes:

1. Any site installed circuits (i.e. basement, heating/cooling, etc.) not to exceed service panel rating of 200 AMP. If additional loads exceed the main panel rating, the purchaser is responsible for site intallation of additional panel and/or adequate service entry. All installation to meet **2017 NEC**, subject to inspection by local jurisdiction.

APPROVED BY
NIA 3/7/2024

Approval of this document does not authorize or approve any deviation or deviations from the requirements of applicable State Laws.

Kip Whitehead

Engineering Department



The design also meets the 2018 IBC and 2018 NDS editions.



BOTTOM CHORD CUT FOR STAIRS

BARLOW NO. 190206
CUT BOTTOM CHORD
Apr. 15, 2019 15:54

Design Check Calculation Sheet
WoodWorks Sizer 11.1

Loads:

Load	Type	Distribution	Pat-tern	Location [ft]		Magnitude		Unit
				Start	End	Start	End	
BC LL	Dead	Full UDL				13.3		plf
KW DL	Dead	Point		10.25		155		lbs
BC LL 1	Live	Partial UDL		0.02	10.25	13.3	13.3	plf
BC LL 2	Live	Partial UDL		10.25	10.98	26.7	26.7	plf
KW LL	Live	Point		10.25		291		lbs
Self-weight	Dead	Full UDL				2.8		plf

Maximum Reactions (lbs), Bearing Capacities (lbs) and Bearing Lengths (in) :

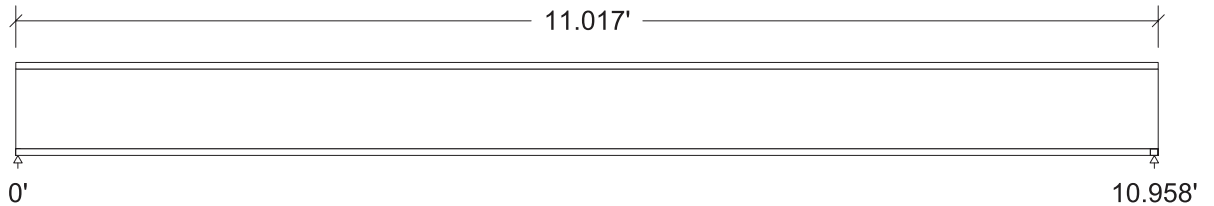

Unfactored:								
Dead	99							233
Live	93							354
Factored:								
Total	192							587
Bearing:								
Capacity								
Beam	319							587
Des ratio								
Beam	0.60							1.00
Load comb	#2							#2
Length	0.50*							0.92
Min req'd	0.50*							0.92
Cb	1.00							1.00
Cb min	1.00							1.00

*Minimum bearing length setting used: 1/2" for end supports

Lumber n-ply, S-P-F, No.1/No.2, 2x10, 1-ply (1-1/2"x9-1/4")

Supports: All - Non-wood

Total length: 11.02'; Clear span: 10.899'; volume = 1.1 cu.ft.

Lateral support: top= full, bottom= full;

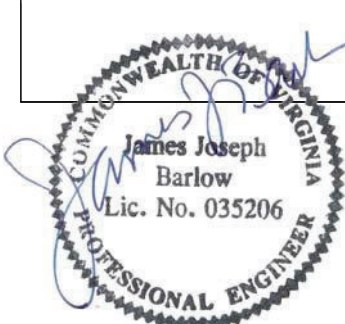

03/24/21



03/12/21

Analysis vs. Allowable Stress and Deflection using NDS 2015 :

Criterion	Analysis Value	Design Value	Unit	Analysis/Design
Shear	fv* = 55	Fv' = 135	psi	fv*/Fv' = 0.41
Bending(+)	fb = 349	Fb' = 962	psi	fb/Fb' = 0.36
Live Defl'n	0.05 = <L/999	0.55 = L/240	in	0.09
Total Defl'n	0.12 = <L/999	0.55 = L/240	in	0.23

*The effect of point loads within a distance d of the support has been included as per NDS 3.4.3.1

Additional Data:

FACTORS:	F/E (psi)	CD	CM	Ct	CL	CF	Cfu	Cr	Cf _{rt}	Ci	Cn	LC#
Fv'	135	1.00	1.00	1.00	-	-	-	-	1.00	1.00	1.00	2
Fb'+	875	1.00	1.00	1.00	1.000	1.100	1.00	1.00	1.00	1.00	-	2
F _{cp} '	425	-	1.00	1.00	-	-	-	-	1.00	1.00	-	-
E'	1.4 million	-	1.00	1.00	-	-	-	-	1.00	1.00	-	2
E _{min} '	0.51 million	-	1.00	1.00	-	-	-	-	1.00	1.00	-	2

CRITICAL LOAD COMBINATIONS:

Shear : LC #2 = D+L, V max = 587, V design* = 513 lbs

Bending(+): LC #2 = D+L, M = 623 lbs-ft

Deflection: LC #2 = D+L (live)

LC #2 = D+L (total)

D=dead L=live S=snow W=wind I=impact Lr=roof live Lc=concentrated E=earthquake

All LC's are listed in the Analysis output

Load combinations: ICC-IBC

CALCULATIONS:

Deflection: EI = 139e06 lb-in²

"Live" deflection = Deflection from all non-dead loads (live, wind, snow...)

Total Deflection = 1.50(Dead Load Deflection) + Live Load Deflection.

Design Notes:

1. WoodWorks analysis and design are in accordance with the ICC International Building Code (IBC 2015), the National Design Specification (NDS 2015), and NDS Design Supplement.
2. Please verify that the default deflection limits are appropriate for your application.
3. Sawn lumber bending members shall be laterally supported according to the provisions of NDS Clause 4.4.1.



04/18/23

03/12/21



04/16/19



03/24/21

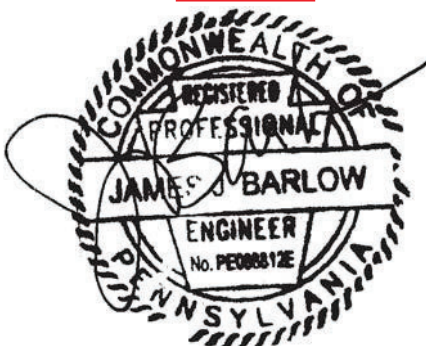

APPROVED BY



3/7/2024

Approval of this document does not authorize or approve any deviation or deviations from the requirements of applicable State Laws.

Kip Whitehead



FULL BOTTOM CHORD w/ BEAM

BARLOW NO. 190206
CUT BOTTOM CHORD UPLIFT
Apr. 15, 2019 16:06

The design also meets the 2018 IBC and 2018 NDS editions.

Design Check Calculation Sheet
WoodWorks Sizer 11.1

Loads:

Load	Type	Distribution	Pat-tern	Location [ft]		Magnitude		Unit
				Start	End	Start	End	
BC DL	Dead	Full UDL				8.0		plf
KW UP	Wind	Point		10.27		-59		lbs
Self-weight	Dead	Full UDL				5.6		plf

Maximum Reactions (lbs), Bearing Capacities (lbs) and Bearing Lengths (in) :

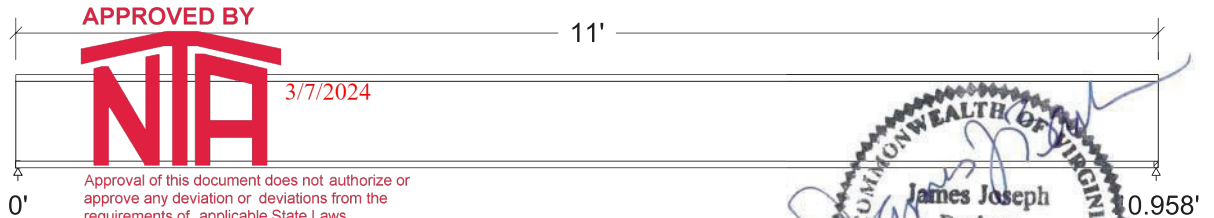

Unfactored:								
Dead	75							75
Wind	-4							-55
Factored:								
Uplift								-10
Total	75							75
Bearing:								
Capacity								
Beam	637							637
Des ratio								
Beam	0.12							0.12
Load comb	#1							#1
Length	0.50*							0.50*
Min req'd	0.50*							0.50*
Cb	1.00							1.00
Cb min	1.00							1.00

*Minimum bearing length setting used: 1/2" for end supports

Lumber n-ply, S-P-F, No.1/No.2, 2x10, 2-ply (3"x9-1/4")

Supports: All - Non-wood
Total length: 11.0'; Clear span: 10.916'; volume = 2.1 cu.ft.
Lateral support: top= full, bottom= full;

Analysis vs. Allowable Stress and Deflection using NDS 2015 :

Criterion	Analysis Value	Design Value	Unit	Analysis/Design
Shear	fv = 3	Fv' = 121	psi	fv/Fv' = 0.03
Bending (+)	fb = 57	Fb' = 866	psi	fb/Fb' = 0.07
Live Defl'n	-0.00 = <L/999	0.55 = L/240	in	0.00
Total Defl'n	0.02 = <L/999	0.55 = L/240	in	0.04

Additional Data:

FACTORS:	F/E (psi)	CD	CM	Ct	CL	CF	Cfu	Cr	Cf _{rt}	Ci	Cn	LC#
F _v '	135	0.90	1.00	1.00	-	-	-	-	1.00	1.00	1.00	1
F _b ' ⁺	875	0.90	1.00	1.00	1.000	1.100	1.00	1.00	1.00	1.00	-	1
F _{cp} '	425	-	1.00	1.00	-	-	-	-	1.00	1.00	-	-
E'	1.4 million	-	1.00	1.00	-	-	-	-	1.00	1.00	-	1
E _{min} '	0.51 million	-	1.00	1.00	-	-	-	-	1.00	1.00	-	1

CRITICAL LOAD COMBINATIONS:

Shear : LC #1 = D only, V max = 75, V design = 64 lbs

Bending(+): LC #1 = D only, M = 204 lbs-ft

Deflection: LC #2 = .6D+W (live)

LC #1 = D only (total)

D=dead L=live S=snow W=wind I=impact Lr=roof live Lc=concentrated E=earthquake

All LC's are listed in the Analysis output

Load combinations: ICC-IBC

CALCULATIONS:

Deflection: EI = 139e06 lb-in²/ply

"Live" deflection = Deflection from all non-dead loads (live, wind, snow...)

Total Deflection = 1.50(Dead Load Deflection) + Live Load Deflection.

Design Notes:

1. WoodWorks analysis and design are in accordance with the ICC International Building Code (IBC 2015), the National Design Specification (NDS 2015), and NDS Design Supplement.
2. Please verify that the default deflection limits are appropriate for your application.
3. Sawn lumber bending members shall be laterally supported according to the provisions of NDS Clause 4.4.1.
4. BUILT-UP BEAMS: it is assumed that each ply is a single continuous member (that is, no butt joints are present) and that each ply is equally top-loaded. Where beams are side-loaded, special fastening details may be required.

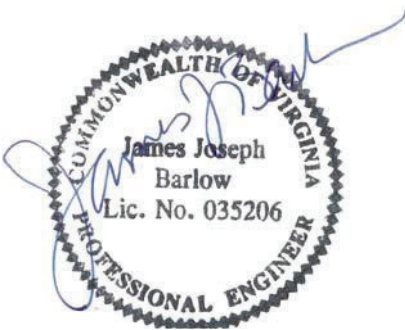

03/24/21



03/12/21

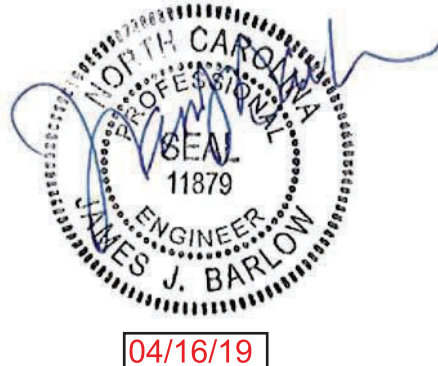

04/16/19

04/18/23

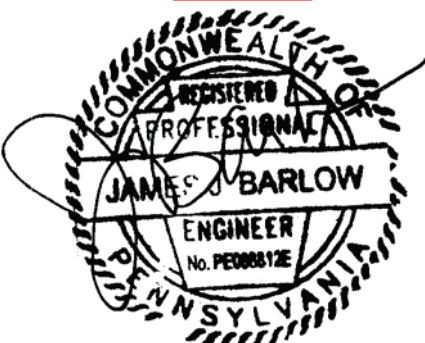

APPROVED BY



3/7/2024

Approval of this document does not authorize or approve any deviation or deviations from the requirements of applicable State Laws.

Kip Whitehead



BOTTOM CHORD STAIR BEAM

BARLOW NO. 190207
STAIR BEAM
Apr. 15, 2019

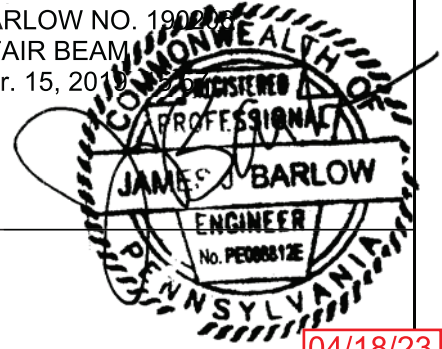

The design also meets the 2018 IBC and 2018 NDS editions.

Design Check Calculation Sheet
WoodWorks Sizer 11.1

Loads:

Load	Type	Distribution	Pat-tern	Location [ft]		Magnitude		Unit
				Start	End	Start	End	
Load1	Dead	Full UDL				117.0		plf
Load2	Live	Full UDL				177.0		plf
Self-weight	Dead	Full UDL				2.8		plf

04/18/23

Maximum Reactions (lbs), Bearing Capacities (lbs) and Bearing Lengths (in) :



Approval of this document does not authorize or approve any deviation or deviations from the requirements of applicable State Laws.
Kip Whitehead

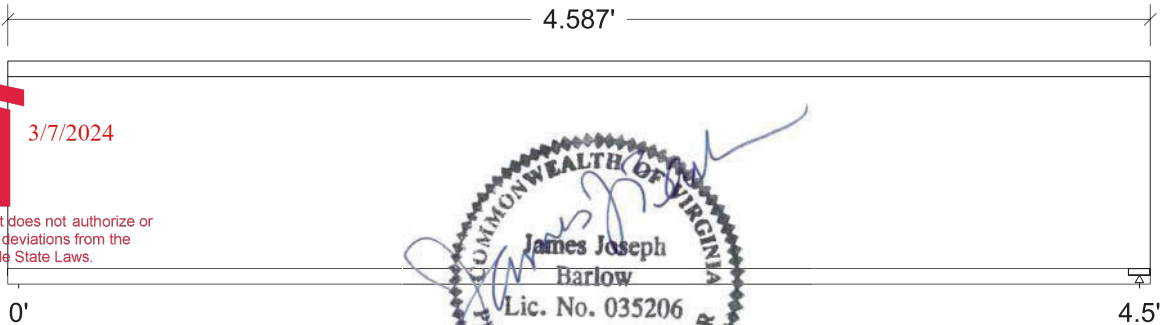

Unfactored:							
Dead	270						270
Live	398						398
Factored:							
Total	668						668
Bearing:							
Capacity							
Beam	668						668
Des ratio							
Beam	1.00						1.00
Load comb	#2						#2
Length	1.05						1.05
Min req'd	1.05						1.05
Cb	1.00						1.00
Cb min	1.00						1.00



03/12/21

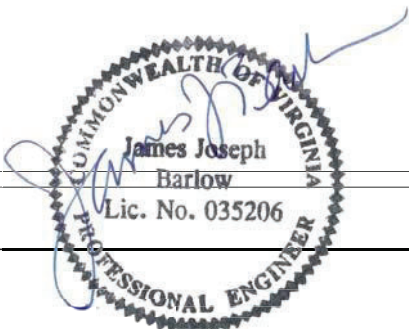

03/24/21

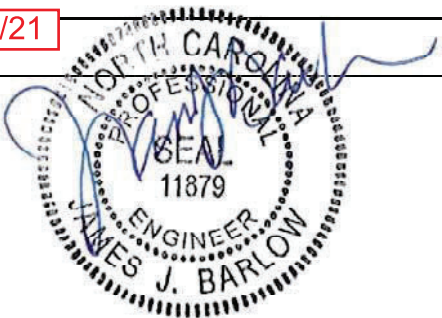

04/16/19

Lumber n-ply, S-P-F, No.1/No.2, 2x10, 1-ply (1-1/2"x9-1/4")

Supports: All - Non-wood

Total length: 4.59'; Clear span: 4.413'; volume = 0.4 cu.ft.

Lateral support: top= full, bottom= full;

Analysis vs. Allowable Stress and Deflection using NDS 2015 :

Criterion	Analysis Value	Design Value	Unit	Analysis/Design
Shear	$f_v = 46$	$F_v' = 135$	psi	$f_v/F_v' = 0.34$
Bending (+)	$f_b = 421$	$F_b' = 962$	psi	$f_b/F_b' = 0.44$
Live Defl'n	$0.01 = <L/999$	$0.23 = L/240$	in	0.05
Total Defl'n	$0.02 = <L/999$	$0.23 = L/240$	in	0.11

Additional Data:

FACTORS:	F/E (psi)	CD	CM	Ct	CL	CF	Cfu	Cr	Cfirt	Ci	Cn	LC#
Fv'	135	1.00	1.00	1.00	-	-	-	-	1.00	1.00	1.00	2
Fb'+	875	1.00	1.00	1.00	1.000	1.100	1.00	1.00	1.00	1.00	-	2
Fcp'	425	-	1.00	1.00	-	-	-	-	1.00	1.00	-	-
E'	1.4 million	-	1.00	1.00	-	-	-	-	1.00	1.00	-	2
Emin'	0.51 million	-	1.00	1.00	-	-	-	-	1.00	1.00	-	2

CRITICAL LOAD COMBINATIONS:

Shear : LC #2 = D+L, V max = 668, V design = 426 lbs

Bending (+): LC #2 = D+L, M = 751 lbs-ft

Deflection: LC #2 = D+L (live)

LC #2 = D+L (total)

D=dead L=live S=snow W=wind I=impact Lr=roof live Lc=concentrated E=earthquake

All LC's are listed in the Analysis output

Load combinations: ICC-IBC

CALCULATIONS:

Deflection: EI = 139e06 lb-in²

"Live" deflection = Deflection from all non-dead loads (live, wind, snow...)

Total Deflection = 1.50(Dead Load Deflection) + Live Load Deflection.

Design Notes:

1. WoodWorks analysis and design are in accordance with the ICC International Building Code (IBC 2015), the National Design Specification (NDS 2015), and NDS Design Supplement.
2. Please verify that the default deflection limits are appropriate for your application.
3. Sawn lumber bending members shall be laterally supported according to the provisions of NDS Clause 4.4.1.

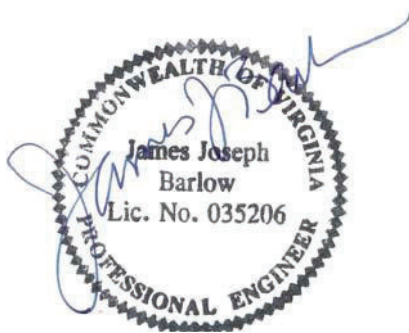

03/24/21



03/12/21



04/16/19

04/18/23

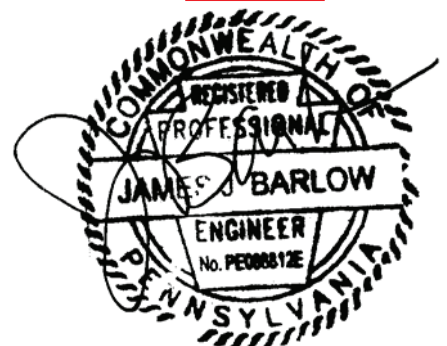

APPROVED BY



3/7/2024

Approval of this document does not authorize or approve any deviation or deviations from the requirements of applicable State Laws.

Kip Whitehead



The design also meets the 2018 IBC and 2018 NDS editions.



BOTTOM CHORD STAIR BEAM
150 mph UPLIFT
BARLOW NO. 190206
STAIR BEAM UPLIFT
Apr. 15, 2019 15:58

Design Check Calculation Sheet
WoodWorks Sizer 11.1

Loads:

Load	Type	Distribution	Pat-tern	Location [ft]		Magnitude		Unit
				Start	End	Start	End	
Load2	Wind	Full UDL				-28.0		plf
Self-weight	Dead	Full UDL				2.8		plf

Maximum Reactions (lbs), Bearing Capacities (lbs) and Bearing Lengths (in) :

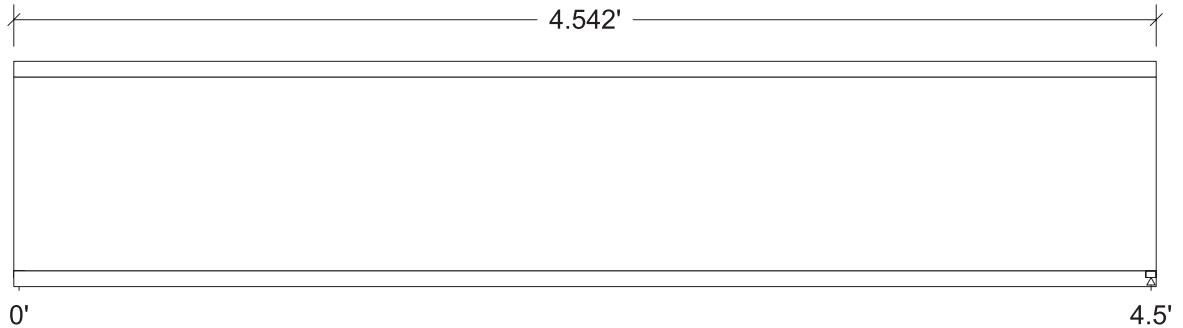

Unfactored:				
Dead	6			6
Wind	-63			-63
Factored:				
Uplift	-59			-59
Total	6			6
Bearing:				
Capacity				
Beam	319			319
Des ratio				
Beam	0.02			0.02
Load comb	#1			#1
Length	0.50*			0.50*
Min req'd	0.50*			0.50*
Cb	1.00			1.00
Cb min	1.00			1.00



03/12/21



04/16/19

*Minimum bearing length setting used: 1/2" for end supports

Lumber n-ply, S-P-F, No.1/No.2, 2x10, 1-ply (1-1/2"x9-1/4")

04/18/23

Supports: All - Non-wood
Total length: 4.54'; Clear span: 4.458'; volume = 0.4 cu.ft.
Lateral support: top= full, bottom= full;

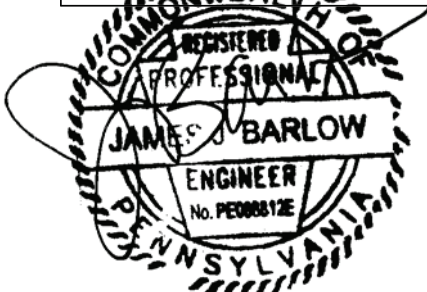

APPROVED BY



3/7/2024

Approval of this document does not authorize or approve any deviation or deviations from the requirements of applicable State Laws.
Kip Whitehead

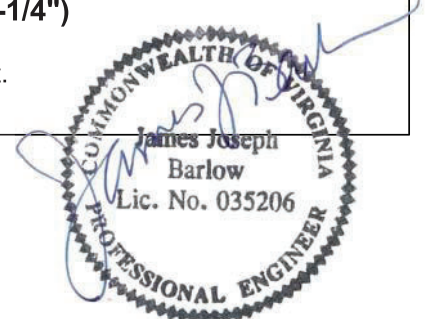

03/24/21

Analysis vs. Allowable Stress and Deflection using NDS 2015 :

Criterion	Analysis Value	Design Value	Unit	Analysis/Design
Shear	fv = 6	Fv' = 216	psi	fv/Fv' = 0.03
Bending (+)	fb = 4	Fb' = 866	psi	fb/Fb' = 0.00
Bending (-)	fb = 36	Fb' = 1540	psi	fb/Fb' = 0.02
Live Defl'n	-0.00 = <L/999	0.23 = L/240	in	0.01
Total Defl'n	-0.00 = <L/999	0.23 = L/240	in	0.01

Additional Data:

FACTORS:	F/E (psi)	CD	CM	Ct	CL	CF	Cfu	Cr	Cf _{rt}	Ci	C _n	LC#
Fv'	135	1.60	1.00	1.00	-	-	-	-	1.00	1.00	1.00	2
Fb'+	875	0.90	1.00	1.00	1.000	1.100	1.00	1.00	1.00	1.00	-	1
Fb'-	875	1.60	1.00	1.00	1.000	1.100	1.00	1.00	1.00	1.00	-	2
F _{cp} '	425	-	1.00	1.00	-	-	-	-	1.00	1.00	-	-
E'	1.4 million	1.00	1.00	1.00	-	-	-	-	1.00	1.00	-	2
E _{min} '	0.51 million	1.00	1.00	1.00	-	-	-	-	1.00	1.00	-	2

CRITICAL LOAD COMBINATIONS:

Shear : LC #2 = .6D+W, V max = 57, V design = 57 lbs
 Bending (+): LC #1 = D only, M = 7 lbs-ft
 Bending (-): LC #2 = .6D+W, M = 64 lbs-ft
 Deflection: LC #2 = .6D+W (live)
 LC #2 = .6D+W (total)

D=dead L=live S=snow W=wind I=impact Lr=roof live Lc=concentrated E=earthquake
 All LC's are listed in the Analysis output
 Load combinations: ICC-IBC

CALCULATIONS:

Deflection: EI = 139e06 lb-in²
 "Live" deflection = Deflection from all non-dead loads (live, wind, snow...)
 Total Deflection = 1.50(Dead Load Deflection) + Live Load Deflection.

Design Notes:

1. WoodWorks analysis and design are in accordance with the ICC International Building Code (IBC 2015), the National Design Specification (NDS 2015), and NDS Design Supplement.
2. Please verify that the default deflection limits are appropriate for your application.
3. Sawn lumber bending members shall be laterally supported according to the provisions of NDS Clause 4.4.1.

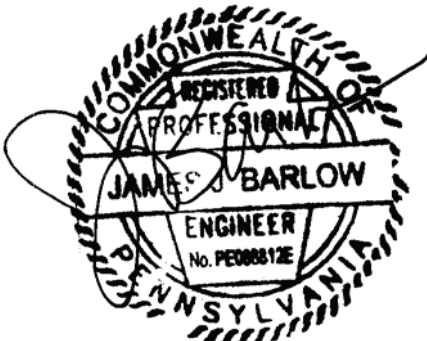
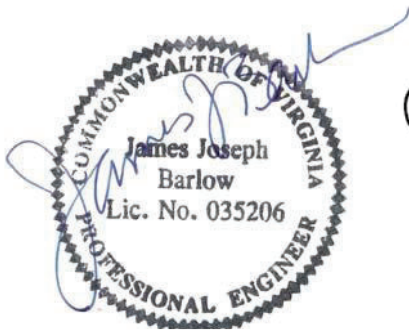



The design also meets the 2018 IBC and 2018 NDS editions.



FULL BOTTOM CHORD w/ BEAM

04/18/23

BARLOW NO. 190206

FULL BOTTOM CHORD

Apr. 15, 2019

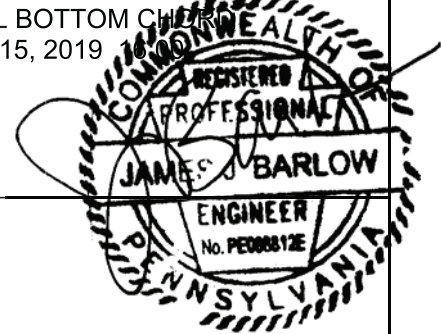

Design Check Calculation Sheet
WoodWorks Sizer 11.1

Loads:

Load	Type	Distribution	Pat-tern	Location [ft]		Magnitude		Unit
				Start	End	Start	End	
BC LL	Dead	Full UDL				13.3		plf
KW DL	Dead	Point		10.27		155		lbs
BC LL 1	Live	Partial UDL		0.02	10.27	13.3	13.3	plf
BC LL 2	Live	Partial UDL		10.27	13.77	26.7	26.7	plf
KW LL	Live	Point		10.27		291		lbs
BEAM DL	Dead	Point		10.98		270		lbs
BEAM LL	Live	Point		10.98		398		lbs
Self-weight	Dead	Full UDL				5.6		plf

Maximum Reactions (lbs), Bearing Capacities (lbs) and Bearing Lengths (in) :

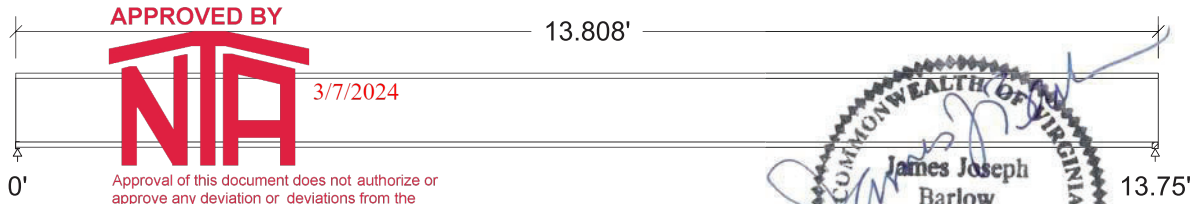

Unfactored:							
Dead	224						461
Live	252						667
Factored:							
Total	477						1128
Bearing:							
Capacity							
Beam	637						1128
Des ratio							
Beam	0.75						1.00
Load comb	#2						#2
Length	0.50*						0.88
Min req'd	0.50*						0.88
Cb	1.00						1.00
Cb min	1.00						1.00

Kip Whitehead

Approval of this document does not authorize or approve any deviation or deviations from the requirements of applicable State Laws.

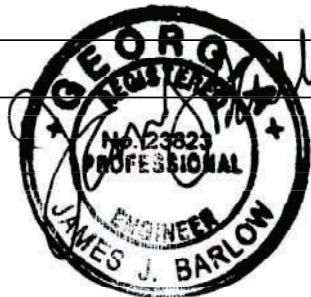

03/12/21

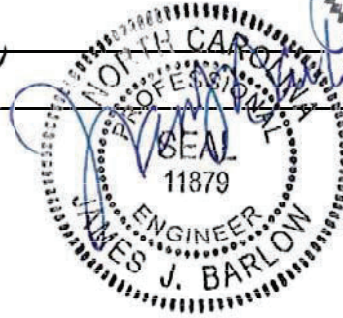

04/16/19

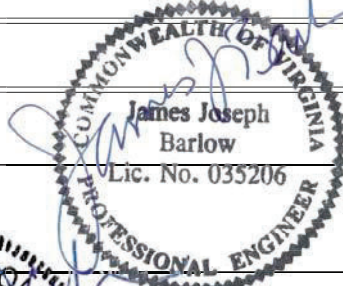

03/24/21

*Minimum bearing length setting used: 1/2" for end supports

Lumber n-ply, S-P-F, No.1/No.2, 2x10, 2-ply (3"x9-1/4")

Supports: All - Non-wood

Total length: 13.81'; Clear span: 13.692'; volume = 2.7 cu.ft.

Lateral support: top= full, bottom= full;

Analysis vs. Allowable Stress and Deflection using NDS 2015 :

Criterion	Analysis Value	Design Value	Unit	Analysis/Design
Shear	$f_v = 59$	$F_v' = 135$	psi	$f_v/F_v' = 0.44$
Bending (+)	$f_b = 896$	$F_b' = 962$	psi	$f_b/F_b' = 0.93$
Live Defl'n	$0.19 = L/857$	$0.69 = L/240$	in	0.28
Total Defl'n	$0.41 = L/402$	$0.69 = L/240$	in	0.60

Additional Data:

FACTORS:	F/E (psi)	CD	CM	Ct	CL	CF	Cfu	Cr	Cfrt	Ci	Cn	LC#
Fv'	135	1.00	1.00	1.00	-	-	-	-	1.00	1.00	1.00	2
Fb'+	875	1.00	1.00	1.00	1.000	1.100	1.00	1.00	1.00	1.00	-	2
Fcp'	425	-	1.00	1.00	-	-	-	-	1.00	1.00	-	-
E'	1.4 million	-	1.00	1.00	-	-	-	-	1.00	1.00	-	2
Emin'	0.51 million	-	1.00	1.00	-	-	-	-	1.00	1.00	-	2

CRITICAL LOAD COMBINATIONS:

Shear : LC #2 = D+L, V max = 1128, V design = 1091 lbs

Bending(+): LC #2 = D+L, M = 3193 lbs-ft

Deflection: LC #2 = D+L (live)

LC #2 = D+L (total)

D=dead L=live S=snow W=wind I=impact Lr=roof live Lc=concentrated E=earthquake

All LC's are listed in the Analysis output

Load combinations: ICC-IBC

CALCULATIONS:

Deflection: EI = 139e06 lb-in²/ply

"Live" deflection = Deflection from all non-dead loads (live, wind, snow...)

Total Deflection = 1.50(Dead Load Deflection) + Live Load Deflection.

Design Notes:

1. WoodWorks analysis and design are in accordance with the ICC International Building Code (IBC 2015), the National Design Specification (NDS 2015), and NDS Design Supplement.
2. Please verify that the default deflection limits are appropriate for your application.
3. Sawn lumber bending members shall be laterally supported according to the provisions of NDS Clause 4.4.1.
4. BUILT-UP BEAMS: it is assumed that each ply is a single continuous member (that is, no butt joints are present) and that each ply is equally top-loaded. Where beams are side-loaded, special fastening details may be required.

APPROVED BY



Approval of this document does not authorize or approve any deviation or deviations from the requirements of applicable State Laws.

Kip Whitehead

04/18/23

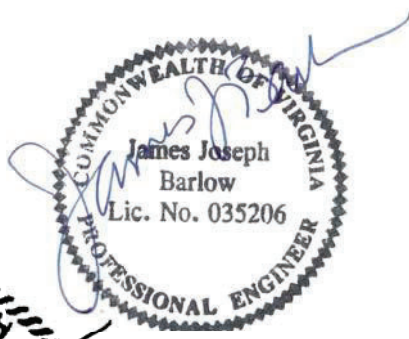

03/24/21



03/12/21

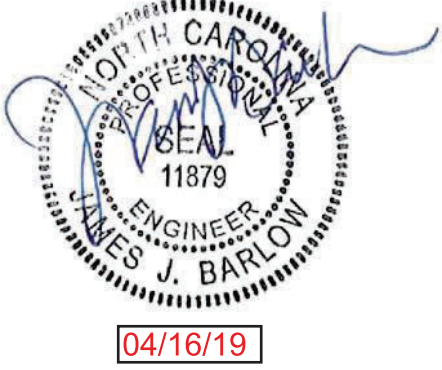

04/16/19

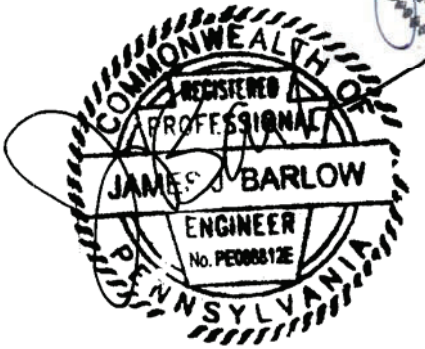



The design also meets the 2018 IBC and 2018 NDS editions.



FULL BOTTOM CHORD w/ BEAM
150 mph UPLIFT
BARLOW NO. 190206
FULL BOTTOM CHORD UPLIFT
Apr. 15, 2019 16:08

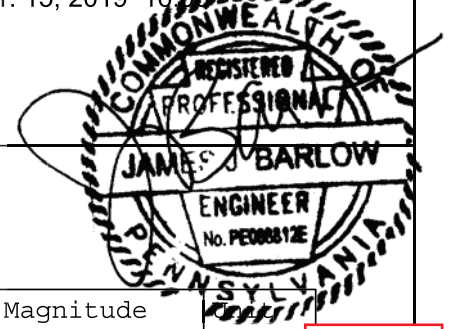

Design Check Calculation Sheet
WoodWorks Sizer 11.1

Loads:

Load	Type	Distribution	Pat-tern	Location [ft]		Magnitude		
				Start	End	Start	End	
BC DL	Dead	Full UDL				8.0		plf
KW UP	Wind	Point		10.27		-59		lbs
BEAM UP	Wind	Point		10.98		-63		lbs
Self-weight	Dead	Full UDL				5.6		plf

04/18/23

Maximum Reactions (lbs), Bearing Capacities (lbs) and Bearing Lengths (in)

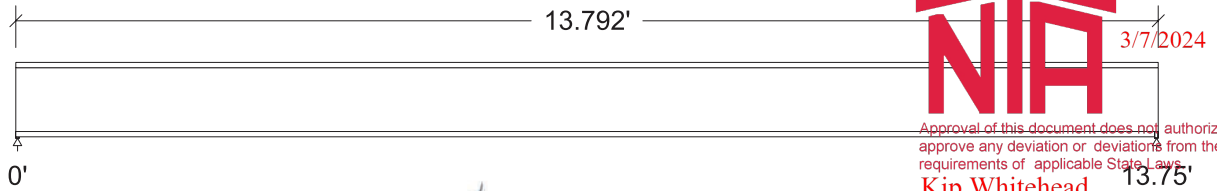

APPROVED BY
NIA
3/7/2024
Approval of this document does not authorize or approve any deviation or deviations from the requirements of applicable State Laws.
Kip Whitehead

Unfactored:				
Dead	94			94
Wind	-28			-94
Factored:				
Uplift				-38
Total	94			94
Bearing:				
Capacity				
Beam	637			637
Des ratio				
Beam	0.15			0.15
Load comb	#1			#1
Length	0.50*			0.50*
Min req'd	0.50*			0.50*
Cb	1.00			1.00
Cb min	1.00			1.00

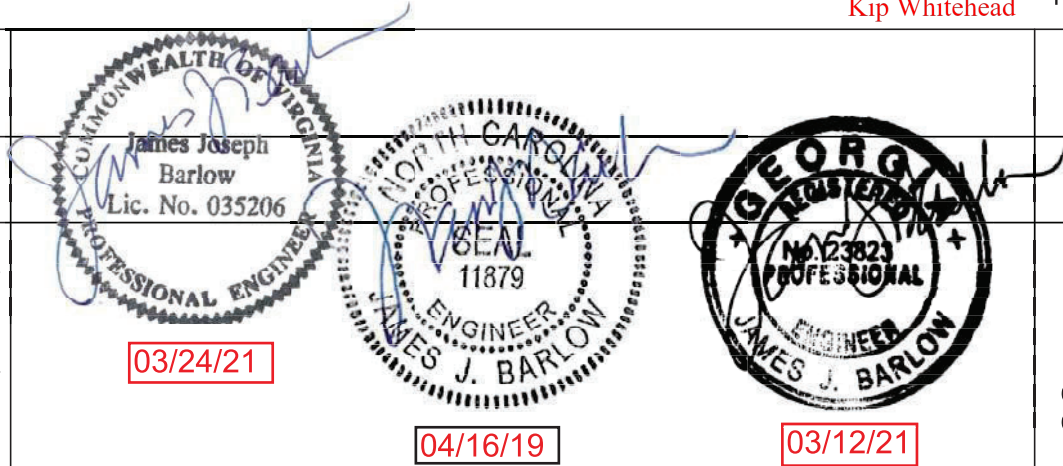

03/24/21

04/16/19

03/12/21

*Minimum bearing length setting used: 1/2" for end supports

Lumber n-ply, S-P-F, No.1/No.2, 2x10, 2-ply (3"x9-1/4")

Supports: All - Non-wood
Total length: 13.79'; Clear span: 13.708'; volume = 2.7 cu.ft.
Lateral support: top= full, bottom= full;

Analysis vs. Allowable Stress and Deflection using NDS 2015 :

Criterion	Analysis Value	Design Value	Unit	Analysis/Design
Shear	$f_v = 4$	$F_v' = 121$	psi	$f_v/F_v' = 0.04$
Bending (+)	$f_b = 90$	$F_b' = 866$	psi	$f_b/F_b' = 0.10$
Bending (-)	$f_b = 19$	$F_b' = 1540$	psi	$f_b/F_b' = 0.01$
Live Defl'n	$-0.03 = <L/999$	$0.69 = L/240$	in	0.04
Total Defl'n	$0.06 = <L/999$	$0.69 = L/240$	in	0.09

Additional Data:

FACTORS:	F/E (psi)	CD	CM	Ct	CL	CF	Cfu	Cr	Cfirt	Ci	Cn	LC#
Fv'	135	0.90	1.00	1.00	-	-	-	-	1.00	1.00	1.00	1
Fb'+	875	0.90	1.00	1.00	1.000	1.100	1.00	1.00	1.00	1.00	-	1
Fb'-	875	1.60	1.00	1.00	1.000	1.100	1.00	1.00	1.00	1.00	-	2
Fcp'	425	-	1.00	1.00	-	-	-	-	1.00	1.00	-	-
E'	1.4 million		1.00	1.00	-	-	-	-	1.00	1.00	-	1
Emin'	0.51 million		1.00	1.00	-	-	-	-	1.00	1.00	-	1

CRITICAL LOAD COMBINATIONS:

Shear : LC #1 = D only, V max = 94, V design = 83 lbs
 Bending(+): LC #1 = D only, M = 322 lbs-ft
 Bending(-): LC #2 = .6D+W, M = 68 lbs-ft
 Deflection: LC #2 = .6D+W (live)
 LC #1 = D only (total)

D=dead L=live S=snow W=wind I=impact Lr=roof live Lc=concentrated E=earthquake
 All LC's are listed in the Analysis output
 Load combinations: ICC-IBC

CALCULATIONS:

Deflection: EI = 139e06 lb-in²/ply
 "Live" deflection = Deflection from all non-dead loads (live, wind, snow...)
 Total Deflection = 1.50(Dead Load Deflection) + Live Load Deflection.

Design Notes:

1. WoodWorks analysis and design are in accordance with the ICC International Building Code (IBC 2015), the National Design Specification (NDS 2015), and NDS Design Supplement.
2. Please verify that the default deflection limits are appropriate for your application.
3. Sawn lumber bending members shall be laterally supported according to the provisions of NDS Clause 4.4.1.
4. BUILT-UP BEAMS: it is assumed that each ply is a single continuous member (that is, no butt joints are present) and that each ply is equally top-loaded. Where beams are side-loaded, special fastening details may be required.

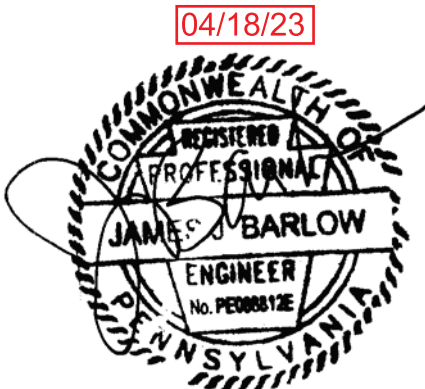

**CONNECTIONS
STAIR OPENING FRAMING**

The design also meets
the 2018 IBC and 2018
NDS editions.

NATIONWIDE CUSTOM HOMES

SEE ADDITIONAL CALCULATIONS FOR MEMBERS AND LOADINGS



BOTTOM CHORD TO STAIR BEAM

GRAVITY REACTION = 587 lbs

GRAVITY CONNECTION:

CHECK FASTENERS: 16d NAIL Z = 92.2 lbs (CD = 1.15, ENDGRAIN)

$$\frac{587 \text{ lbs}}{92.2 \text{ lbs/FASTENER}} = 6.4 \text{ FASTENERS}$$

USE (7) 16d NAIL(S) THROUGH BEAM INTO CHORD ENDGRAIN

ALTERNATE:

SIMPSON LUS28-2 FLOOR = 1315 lbs

$$1315 \text{ lbs} > 587 \text{ lbs}$$

OK

TENSION = 1437 lbs

TENSION CONNECTION:

CHECK FASTENERS: 16d NAIL Z = 98.1 lbs (CD = 1.15, 7/16" SIDE MEMBER)

$$\frac{1437 \text{ lbs}}{98.1 \text{ lbs/FASTENER}} = 14.6 \text{ FASTENERS}$$

USE (15) 16d NAIL(S) THROUGH SHEATHING INTO CUT BOTTOM CHORDS

1437 lbs x 12 / 24 in O.C. = 719 plf

CHECK FASTENERS: 16d NAIL Z = 98.1 lbs (CD = 1.15, 7/16" SIDE MEMBER)

$$\frac{719 \text{ plf}}{98.1 \text{ lbs/FASTENER}} = 7.3 \text{ FASTENERS/ft}$$

USE (2) ROWS OF 16d NAIL(S) THROUGH SHEATHING INTO STAIR BEAM AT 3 in O.C.

ALTERNATE:

SIMPSON LSTA30 TENSION = 1640 lbs

$$1640 \text{ lbs} < 718.5 \text{ lbs}$$

OK

USE (1) SIMPSON LSTA30 ATTACHED TO EACH NARROW FACE OF BOTTOM WRAPPED AROUND STAIR BEAM



03/12/21

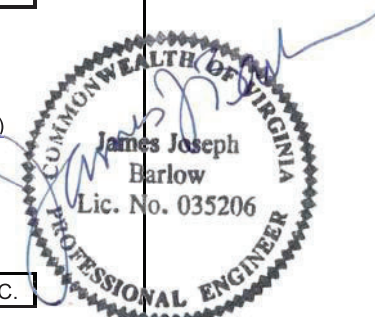

03/24/21

04/18/23

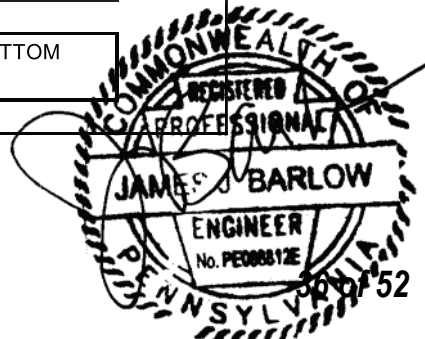

3/7/2024

Approval of this document does not authorize or approve any deviation or deviations from the requirements of applicable State Laws.
Kip Whitehead

**CONNECTIONS
STAIR OPENING FRAMING**



NATIONWIDE CUSTOM HOMES



STAIR BEAM

AT ENDS GRAVITY REACTION = 668 lbs

UPLIFT CONNECTION:

SIMPSON LUS28-2 FLOOR = 1315 lbs

1315 lbs	>	668 lbs
OK		

TENSION LOAD = 719 plf x 4.75 ft / 2 = 1708 lbs

TENSION REACTION = 1708 lbs

TENSION CONNECTION:

CHECK FASTENERS: 16d NAIL Z = 98.1 lbs (CD = 1.15, 7/16" SIDE MEMBER)

<u>1708 lbs</u>	=	17.4 FASTENERS
98.1 lbs/FASTENER		

USE (18) 16d NAIL(S) THROUGH SHEATHING INTO BOTTOM CHORD SCAB

PLUS:

SIMPSON MSTA30 TENSION = 1820 lbs

1820 lbs	>	1708 lbs
OK		

USE (1) SIMPSON MSTA30 ATTACHED TO SCAB ACROSS MATING LINE

BOTTOM CHORD TO MATING WALL BEAM

GRAVITY REACTION = 1128 lbs

GRAVITY CONNECTION:

CHECK FASTENERS: 16d NAIL Z = 92.2 lbs (CD = 1.15, ENDGRAIN)

<u>1128 lbs</u>	=	12.2 FASTENERS
92.2 lbs/FASTENER		

USE (13) 16d NAIL(S) THROUGH BEAM INTO CHORD ENDGRAIN

ALTERNATE: 04/18/23

SIMPSON LUS28-2 FLOOR = 1315 lbs

1315 lbs	>	1128 lbs
OK		

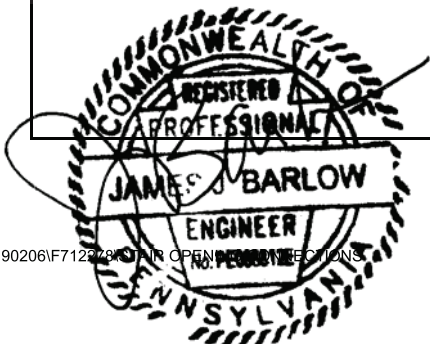
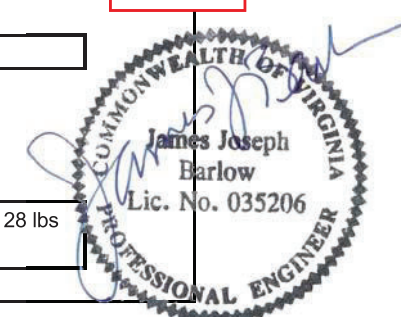

SmartExhaust™

Bath Fan/Light Switch with Ventilation Control & Delay Timer

The SmartExhaust™ Bath Fan/Light Switch is a simple and efficient solution for achieving adequate bathroom ventilation and meeting exhaust ventilation requirements. The SmartExhaust™ is designed to replace the bathroom fan and light switches with one smart controller and features programmable settings for running the exhaust fan as much or as little as you want, automatically.



Toggle (Part # SE1-W)

Rocker (Part # SED-S)

Features & Benefits

- Earn LEED and ENERGY STAR points for enhanced exhaust ventilation*
- Makes standard bath fans ASHRAE 62.2 compliant*
- Smart microprocessor provides precise, user-controlled ventilation
- Works with most incandescent, CFL, and LED lights**
- Optional light and fan timeout after 60 mins (Rocker style only)
- Available in toggle and rocker models in a variety of colors

*When used with ASHRAE 62.2 compliant fans

**Rocker style not compatible with all LED bulbs. Dimmable LED bulb recommended

Product Details

The SmartExhaust™ is a bath fan and light switch* that also serves as a ventilation controller and fan delay timer. This product provides whole house exhaust ventilation. (*Wiring the SmartExhaust™ to operate a light is optional)

With other fan and light switches, the time that someone is occupying the bathroom does not always provide sufficient run time for the fan to eliminate bathroom humidity or contaminants. Using the SmartExhaust™ **Ventilation** and **Delay** settings, the fan can be set to run on a timer so that adequate ventilation can be met even after someone exits the bathroom.

Using the **Ventilation** setting, the user is able to set the number of minutes per hour that the bathroom exhaust fan should run to achieve desired/required ventilation. Using the **Delay** setting, the user is able to set the number of minutes the fan should run after the SmartExhaust™ switch has been turned off. When the switch is turned off, the fan continues to run for the set delay time.

By combining the fan switch with the light switch, the SmartExhaust™ also becomes an occupancy sensor.

Specifications

Light: 450 Watts @ 120 VAC (Blue Wire)

Fan: 150 Watts @ 120 VAC (Red Wire)

Operation: 120 VAC 60hz ± 10% (Red Wire)

2.5" Minimum wall box recommended

Cover plate not included, use any standard switch plate

APPROVED BY



3/7/2024

Approval of this document does not authorize or approve any deviation or deviations from the requirements of applicable State Laws.

Kip Whitehead



www.AirCycler.com | info@aircycler.com

Configuring Ventilation Time

To properly set the VENTILATION time on your SmartExhaust™ you will need to know the code required CFM (Cubic Feet Per Minute) for your home and the Fan CFM. Follow this simple equation to calculate the VENTILATION min/hr.

$$\frac{\text{Code Required Ventilation in CFM}}{\text{Fan CFM}} = \text{Hour Fraction}$$

$$\text{Hour Fraction} \times 60 \text{ Minutes} = \text{Ventilation Settings in minutes}$$

CFM = Cubic Feet Per Minute



3/7/2024

Approval of this document does not authorize or approve any deviation or deviations from the requirements of applicable State Laws.
Kip Whitehead

Example

A Normal Hour of Operation with No Occupancy

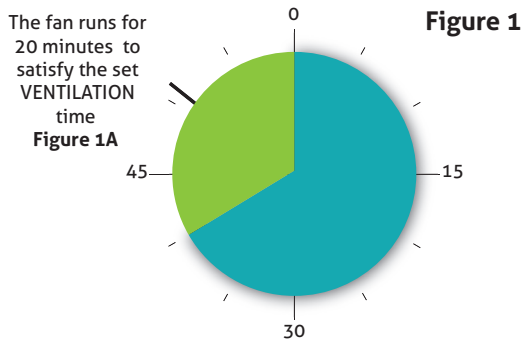

The user wants to VENTILATE the bathroom for 20 minutes every hour with a 10 minute fan DELAY

Figure 1

- The VENTILATION dial is set to 20 min/hr.
- The SmartExhaust™'s microprocessor performs the following equation to determine when to run the fan to meet the VENTILATION setting, based on 1 hour (60 mins).
60 MINS - VENTILATION SETTING = START VENT TIME
60 MINS - 20 MINS = 40 MINS
- The SmartExhaust™ will turn on 40 minutes into the hour and run for 20 minutes. (Figure 1A)

A Normal Hour of Operation with 5 Minutes of Occupancy and 10 Minute Fan Delay (Total Ventilation Set to 20 Min.)

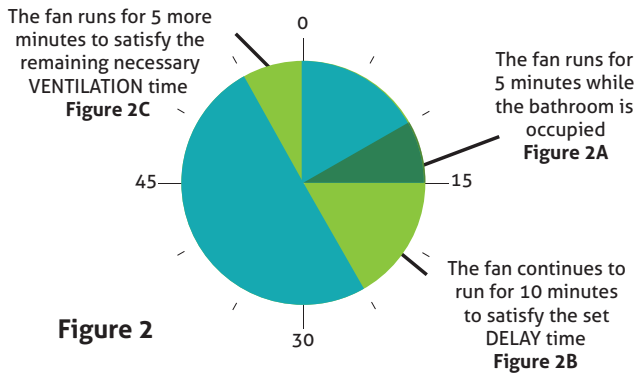
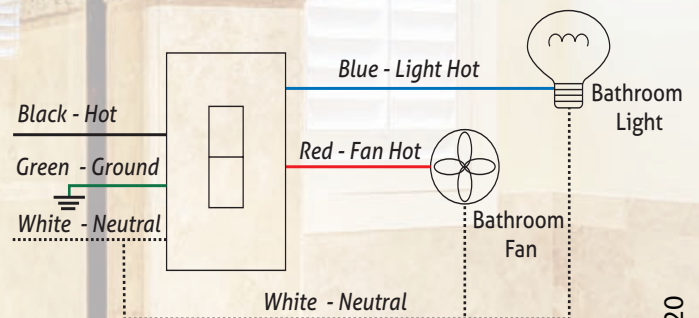

Figure 2

- The DELAY dial is set to 10 min/hour
- Someone uses the bathroom for 5 minutes and manually turns the SmartExhaust™ on. The microprocessor logs this 5 minutes of use. (Figure 2A)
- The occupant exits the bathroom, turning the switch off, and the SmartExhaust™ continues to run the fan for the 10 minutes of DELAY run time. (Figure 2B)
5 MINS OF MANUAL USE + 10 MINS OF DELAY TIME = 15 MINUTES OF VENTILATION
- 15 minutes will be subtracted from the total required 20 minutes of VENTILATION time. 55 minutes into the hour, the fan will turn on and run for the 5 additional minutes needed to complete the required ventilation. (Figure 2C)

Part No:	Description:
SE1-W	SmartExhaust™ Toggle - White
SE1-A	SmartExhaust™ Toggle - Almond
SED-S	SmartExhaust™ Rocker (Includes White Rocker)
SEDR-A	Almond Rocker Replacement
SEDR-BL	Black Rocker Replacement
SEDR-BR	Brown Rocker Replacement
SEDR-I	Ivory Rocker Replacement

Wiring Diagram



This product may be covered by one or more of the following patents and patents pending: 8,185,244



Approval of this document does not authorize or approve any deviation or deviations from the requirements of applicable State Laws.
Kip Whitehead

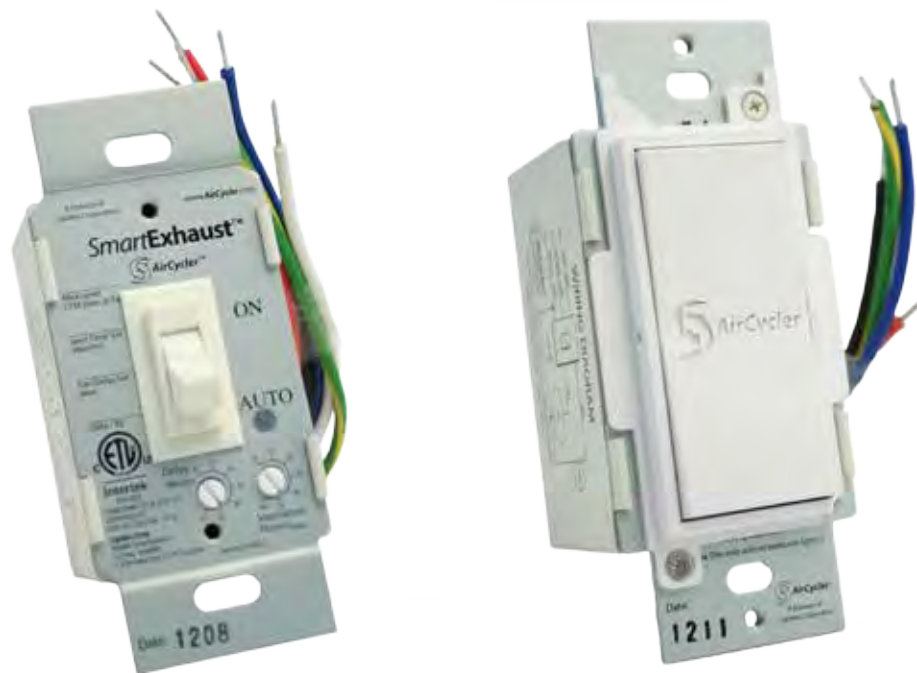

SmartExhaust[™]

Installation & User's Guide

VENTILATION MADE BREEZY![™]
a breeze to install • a breeze to use

INTRODUCTION

The SmartExhaust™ is designed to replace bathroom fan and light switches and provide both functions with one easy operation. By using a microprocessor to monitor and control operation, the SmartExhaust™ delivers a precise amount of ventilation.

BENEFITS

- Earn LEED and ENERGY STAR points for enhanced exhaust ventilation*
- Make standard bath fans ASHRAE 62.2 compliant*
- Replaces both fan and light switches for one easy operation
- Microprocessor technology provides precise ventilation times
- Programmable DELAY and VENTILATION settings
- Excess manual and/or delay operation is subtracted from the next hour's programmed ventilation time
- Works with most incandescent, CFL, fluorescent and LED lights
- Optional light and fan time out after 60 minutes (Rocker version only)

*When used with ASHRAE 62.2 compliant fans

SAFETY CONSIDERATIONS

Read and follow manufacturer's instructions carefully. Follow all local electrical codes during installation. All wiring must conform to local and national electrical codes. Improper wiring or installation may result in personal injury or product and property damage.

INSTALLATION

1. Do not connect this device to aluminum wire.
2. Use with copper or copper clad wire only.
3. TURN POWER OFF at circuit breaker or fuse panel.
4. Remove cover plate and existing switch from wall box if there is one already installed.
5. Connect the wires in the wall box using the supplied wire nuts.
Wires must have $\frac{3}{4}$ inch of bare copper exposed. Twist wires together tightly with supplied wire nuts. Make sure no bare copper is exposed. Secure connections with electrical tape. If a light is not connected, be sure to attach a wire nut to unused blue wire and secure with electrical tape.
6. Mount SmartExhaust™ switch in to wall box with supplied mounting screws.
7. Set desired DELAY time by turning dial to desired minutes.
8. Set desired VENTILATION time by turning dial to desired minutes per hour.
9. Record settings on face plate with an indelable marker and snap rocker assembly onto face plate.
10. Turn on power at circuit breaker or fuse box.

Note: To fully comply with ASHRAE 62.2 - Attach clear ASHRAE sticker to face of switch plate.



Approval of this document does not authorize or approve any deviation or deviations from the requirements of applicable State Laws.

Kip Whitehead

WIRING DIAGRAM

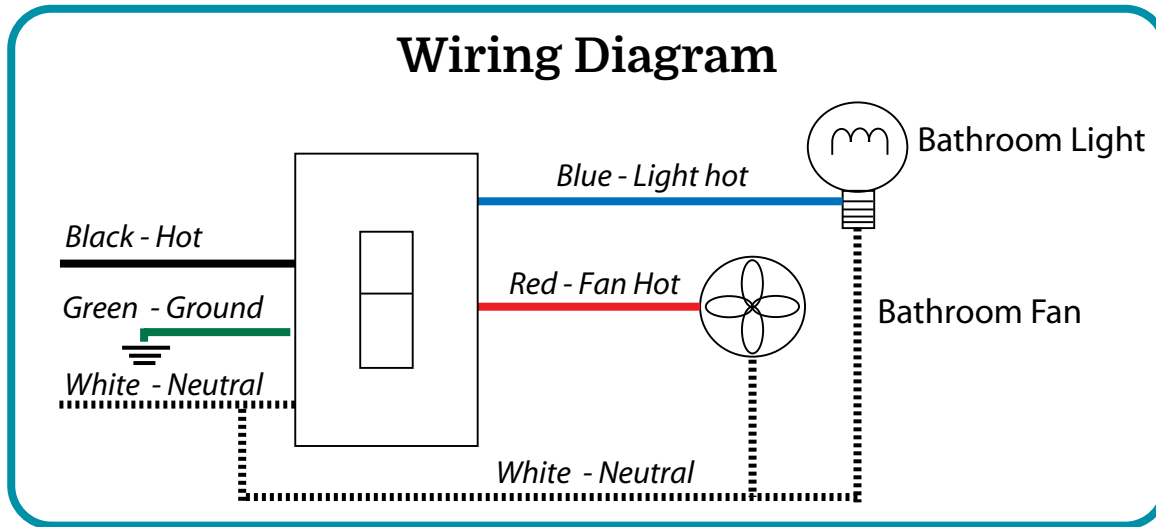

OPERATING INSTRUCTIONS

- Move switch up to turn on the fan and light
- Move switch down to turn off the light. The fan will continue to run for a pre-set DELAY time (unless manually canceled)
- To cancel DELAY time for the toggle version, turn the switch off and back on again within three seconds. Within another three seconds, turn the switch off and the fan will shut off canceling the DELAY for that use. For the Rocker version, simply turn the switch off again after use.
- DELAY will not activate until the light/fan has been on for at least 10 seconds
- The fan will automatically come on once per hour for the pre-set VENTILATION time.

OPERATION

The SmartExhaust™ has a microprocessor in it that reads the two settings dials. If for example the VENTILATION dial is set to 20 minutes/hour, the micro-processor subtracts 20 minutes from 60 minutes and determines it needs to come on 40 minutes into the hour and run for the remaining 20 minutes of that hour.

Now if the DELAY dial is set to 10 minutes and someone uses the bathroom for 5 minutes, the microprocessor will keep track of the 5 minutes of use. Then when the person leaves after 4 minutes and turns the light switch off, the microprocessor will keep the fan on for 10 more minutes of the DELAY setting. This will add up to 14 minutes of total fan run time for that hour. The microprocessor will now subtract the 14 minutes of manual and delay time from the required 20 minutes of VENTILATION time and come up with 6 minutes needed to run at the end of the hour. Now 54 minutes into the hour the fan will come on and run for 6 more minutes. Resulting in 20 minutes of total run time that hour.

APPROVED BY

NIA

3/7/2024

Approval of this document does not authorize or approve any deviation or deviations from the requirements of applicable State Laws.

Kip Whitehead

Additional SmartExhaust™ Rocker Model Features

Adjustable Dim up/Dim down rates:

The dimmer function of this switch is designed for use only with permanently installed incandescent lighting fixtures. Do not use dim rates on fluorescent lighting, transformer supplied lighting/appliances, motorized appliances or receptacles. The incandescent lighting controlled by this dimmer switch must not exceed a total of 400 watts.

The time required to reach full brightness when turned on or full off when turned off, can be set from 0-6 seconds. Use the DELAY dial to set the dim up rate and VENTILATION dial to set the dim down rate. For example if you want it to take 5 seconds to reach full brightness and 3 seconds to reach full off, set DELAY to 5 and VENTILATION to 3. Then pull the small power button on the lower right corner of the switch to the off position. Now using the setting tool molded into the rocker, hold down both push buttons in the center of the switch and at the same time push in the power cut off button while continuing to hold in the push buttons. In 5 seconds the light will dim up to full brightness and then back off using the settings you just set. Last, return the DELAY and VENTILATION dials to the required DELAY and VENTILATION time.

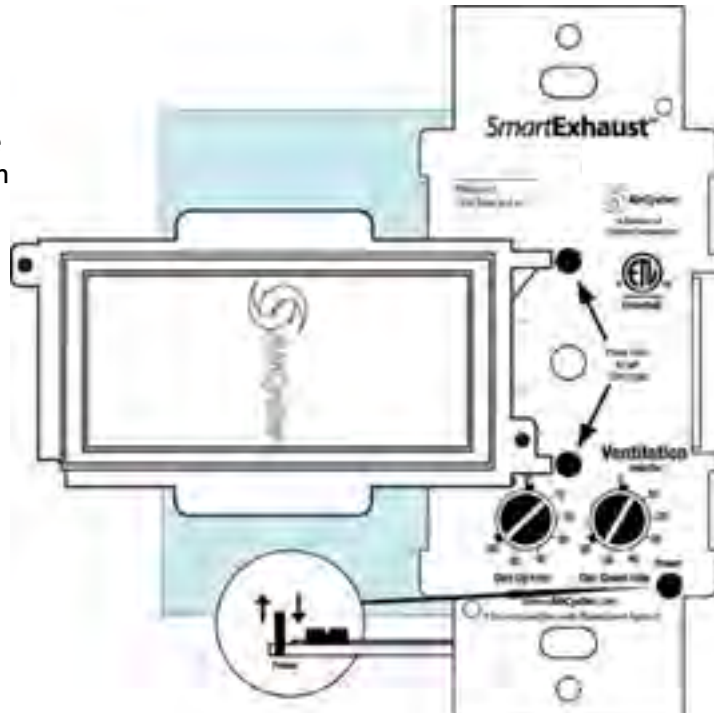

Night light function: (incandescent lights only)

If you have set a dim up rate, anytime you press the on button again after the initial push, the light will stop at that brightness level. This is great for late at night visits to the bathroom when you don't want or need full brightness of the light(s). A quick double tap will turn on the light at a low brightness and stop it there.

Double tap delay cancel:

If after leaving the bathroom you don't want the fan to run for its set DELAY time, simply tap the bottom of the rocker again and the delay time will be canceled.

*Double tap - Fan may remain on if doing vent time.

Note: When changing light bulbs, pull power switch up to disable power to light sockets.

Auto off:

This default setting will automatically turn the fan and light off if the light has been left on for more than 60 minutes.

To disable this feature: Pull the power button out, then using the setting tool on the rocker frame, press the BOTTOM button while pushing the power button back down. The blue LED should come on. Hold the BOTTOM button for 5 seconds. The bathroom light will flash once to indicate this feature is now disabled.

To re-enable this feature: Pull the power button out. Using the setting tool, hold down the TOP button while pushing the power button back down. Hold the UP button for 5 seconds until the light flashes twice, indicating AUTO OFF is enabled.

TROUBLESHOOTING & FREQUENTLY ASKED QUESTIONS

What if you're only in the bathroom for a few seconds?

You have to have the switch on for 10 full seconds before the microprocessor will start counting time and enable the DELAY function. If you turn the switch back off within 10 seconds, the fan shuts off and no time is counted.

What if you don't want the DELAY time to run after you use the bathroom?

To cancel DELAY time for the toggle version, turn the switch off and back on again within three seconds. Within another three seconds, turn the switch off and the fan will shut off canceling the DELAY for that use. For the rocker version, simply turn the switch off again after use.

What if manual and DELAY time exceeds VENTILATION time?

The microprocessor will calculate the excess ventilation time and subtract it from the total VENTILATION time for the next hour.

If you're SmartExhaust™ is not operating correctly check:

Does the device have power?

Turn the VENTILATION dial to 60 minutes. The fan will come on within 20 seconds if the device is powered. If you have the rocker version, tap the top of the rocker to turn on both the light and the fan. If you have the toggle version, you must hear the fan turn on to verify the microprocessor is running.

Is the device wired correctly?

The SmartExhaust™ will not operate correctly if it is not wired correctly.

Technical Support:

info@aircycler.com

APPROVED BY

NIA

3/7/2024

INSTALLATION AND OPERATING INSTRUCTIONS

VENTILATION FAN / DIMMABLE LED LIGHT

READ AND SAVE THESE INSTRUCTIONS

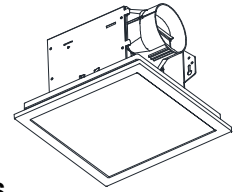

General Safety Information

1. Make sure that the electric service supply voltage is AC 120V, 60Hz.
2. Follow all local electrical and safety codes, as well as the National Electrical Code (NEC) and the Occupational Safety and Healthy Act (OSHAAct).
3. Always disconnect the power source before working on or near the ventilating fan, motor or junction box.
4. Protect the power cord from sharp edges, oil, grease, hot surfaces, chemicals or other objects.
5. Do not kink the power cord.
6. Do not install the unit where ducts are configured as shown in Fig. A.
7. Provide suction parts with proper ventilation.
8. This unit is UL listed for use over a bathtub or shower when installed in a GFCI protected branch circuit.

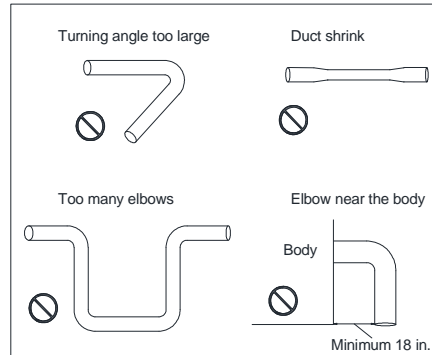

Fig. A

CAUTION

1. For General Ventilating Use Only. Do Not Use To Exhaust Hazardous Or Explosive Materials And Vapors.
2. Not for use in cooking area. (Fig. B)
3. This product must properly connect to the grounding conductor of the supply circuit.
4. To reduce the risk of injury to persons, install the fan at least 8.2 feet (2.5m) above the floor.

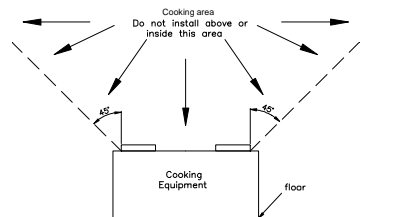

Fig. B

WARNING

TO REDUCE THE RISK OF FIRE, ELECTRIC SHOCK, OR INJURY TO PERSONS, OBSERVE THE FOLLOWING:

1. Use this unit only in the manner intended by the manufacturer. If you have any questions, contact the manufacturer.
2. Before servicing or cleaning the unit, switch power off at service panel and lock the service disconnecting means to prevent power from being switched on accidentally. When the service disconnecting means cannot be locked, securely fasten a prominent warning device, such as a tag, to the service panel.
3. Installation work and electrical wiring must be done by qualified person(s) in accordance with all applicable codes and standards, including fire-rated construction.
4. Sufficient air is needed for proper combustion and exhausting of gases through the flue (chimney) of fuel burning equipment to prevent back drafting. Follow the heating equipment manufacturer's guideline and safety standards such as those published by the National Fire Protection Association (NFPA), and the American Society for Heating, Refrigeration and Air Conditioning Engineers (ASHRAE), and the local code authorities.
5. When cutting or drilling into ceiling, do not damage electrical wiring and other hidden utilities.
6. Ducted fans must always be vented to the outdoors.
7. If this unit is to be installed over a tub or shower, it must be marked as appropriate for the application and be connected to a GFCI (Ground Fault Circuit Interrupter) – protected branch circuit.
8. Do not use this unit with any other solid-state control device. Solid-state controls devices may cause harmonic distortion, which can cause a motor humming noise.
9. **NEVER** place a switch where it can be reached from a tub or shower.
10. Not to be installed in a ceiling thermally insulated to a value greater than R40. (This is required for installation in Canada only).

INSTALLATIONS

Proper insulation around the fan to minimize building heat loss and gain. 4" circular duct is recommended for installation. The ducting from this fan to the outside of building has a strong effect on the air flow, noise and energy use of the fan. Use the shortest, straightest duct routing possible for best performance, and avoid installing the fan with smaller ducts than recommended. Insulation around the ducts can reduce energy loss and inhibit mold growth. Fans installed with existing ducts may not achieve their rated air flow.

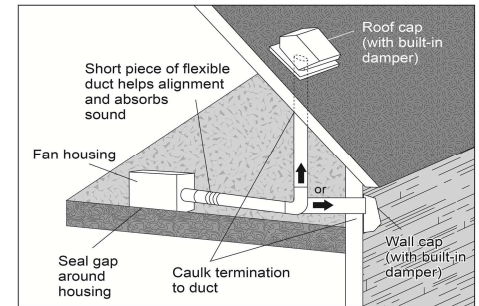

Install with wood frame

Model No.	ITG100LED
Install Dim. (Inch)	7-1/2 x 7-1/4

1. Remove motor plate from housing by removing three screws. (Fig. C-1)
2. Remove wiring cover from housing by pulling straight out. Choose a hole and use a slotted screwdriver to remove it. (Fig. D)
3. Follow all local electrical and safety codes. **NEVER** place a switch where it can be reached from a tub or shower. Connect wires as shown in wiring diagrams. (Fig. E)
4. Using wire nuts (not provided) connect house power cable to ventilating fan wires. 14 AWG (2.1 mm²) is the smallest conductor that shall be used for branch-circuit wiring. (Fig. F)
5. Insert the duct into the duct connector and tape all ductworks connection to make them secure and airtight. Install the duct with a gradient 1°-2° to the outside. (Fig. G)
6. **New installation prior to finishing the ceiling:** Insert the fan between joists. Make sure the fan body is level and perpendicular with the joist. (Fig. H)
7. **Replacement installation:** After making electrical and ductwork connections (see steps 2-5), nail housing in place. Drive nails through the housing where indicated by arrows. (Fig. I)
8. **New installation in an existing ceiling:** Bend tabs outward 90° (Use a screw driver if desired) and position housing so that tabs rest against bottom edge of joists (or front of stud). Nail housing to joist or stud using four nails to ensure a solid, quiet installation. Ceiling installations: Tabs on opposite side of housing can be bent outward to rest on top of 1/2" ceiling material and provide extra stability. (Fig. J)
9. Insert the motor plug connector and locking the fan body back by using three screws. (Fig. C-2)
10. Insert the LED lighting plug connector into the housing. Squeeze grille springs together and insert the mounting springs into the slots of the housing and mount the grille to the fan body.

SUPPLIED ACCESSORIES

Part name	Appearance	Quantity
Grille		1
Fan & Housing		1
4" Duct		1
Screw (M4x12)		3



Push grille up against ceiling. When the power on, check for abnormal vibration or sound. (Fig. K)

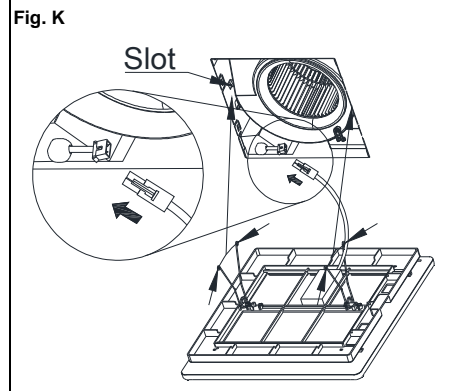
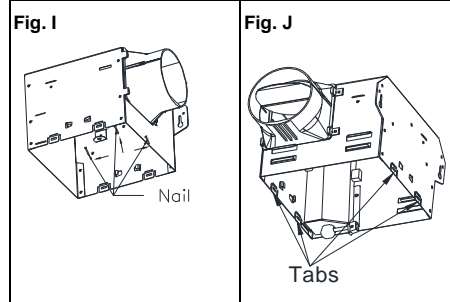
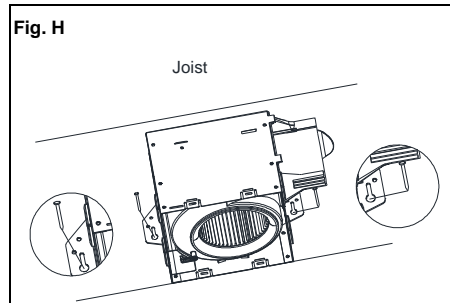
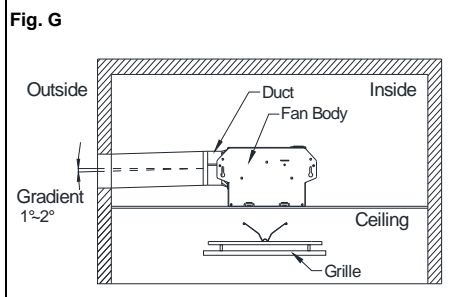
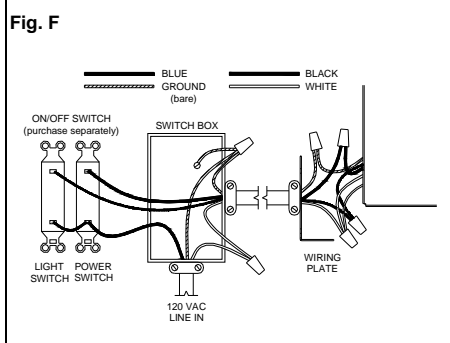
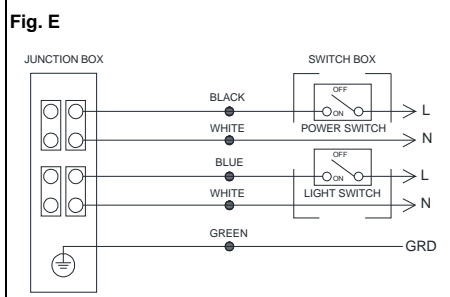
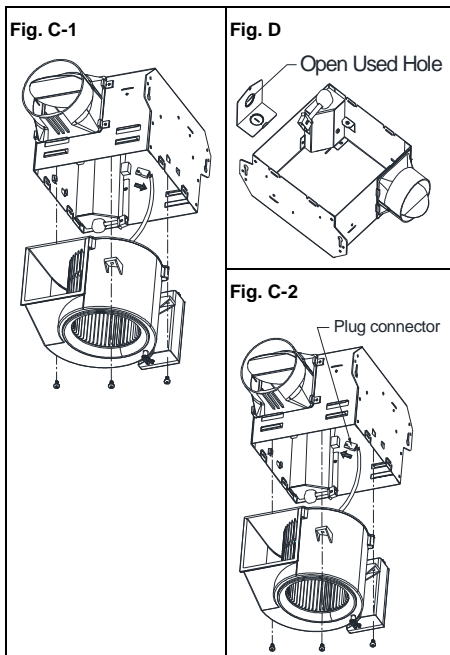

DIMENSIONS

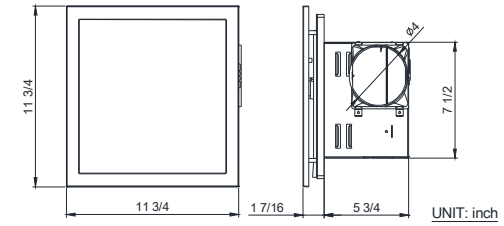

WARRANTY

DELTA ELECTRONICS THREE YEAR LIMITED WARRANTY

Delta Electronics Inc. ("Delta Electronics") warrants to the original consumer purchaser in the USA that the Breez ventilation fan products will be free from defects in material or workmanship. This warranty is limited to three (3) years from the original date of purchase.

Limitations and Exclusions

1. During the warranty period, a replacement for any defective product will be supplied free of charge for installation by the consumer. The warranty provided herein does not cover charges for labor or other costs incurred in the troubleshooting, repair, removal, and installation service.
2. All returns of defective parts or products must include the product model number, and must be made through an authorized Delta Electronics distributor. Authorized returns must be shipped prepaid. Repaired or replacement products will be shipped by Delta Electronics F.O.B. shipping point.
3. Delta Electronics shall not be liable for any indirect, incidental, consequential, punitive, or special damages arising out of or in connection with products use or performance, regardless of the form of action whether in contract, tort (including negligence), strict product liability or otherwise.
4. This warranty does not extend to fluorescent lamp starters and tubes.
5. The warranty does not cover if user does not comply with manufacture's installation manual.
6. To qualify for warranty service, you must notify Delta Electronics at the address or telephone number below.
7. Delta Electronics shall have no liability to the original owner-user with respect to any defect caused by abuse, misuse, neglect, improper transportation or storage, improper testing, improper installation, improper operation, improper use, improper maintenance, improper repair, improper alteration, improper modification, tampering or accident of products or parts thereof, or unusual deterioration or degradation of products or parts thereof due to a physical environment beyond the requirements of products' specifications.

Address: 46101 Fremont Boulevard, Fremont, CA 94538
US Toll Free Number: 1-888-979-9889

OPERATION

Turn the power switch ON/OFF to operate the fan/LED light.

MAINTENANCE:

Disconnect the power source before working on the unit. Routine maintenance must be done every year.

CAUTION:

1. Never use gasoline, benzene, thinner or any other such chemicals for cleaning the ventilating fan.
2. Do not allow water to enter the motor.
3. Do not soak resin parts in water over 140 °F (60°C).

CLEANING:

1. Pull down the spring to remove the grille.
2. Wash and clean the grille. (Use non-abrasive kitchen detergent and wipe dry with a new cloth.)
3. Remove dust and dirt from the ventilating fan using a vacuum cleaner.
4. Using a cloth dampened with kitchen detergent, remove any dirt from the ventilating fan. Wipe dry with a new cloth.
5. Replace the grille.

SPECIFICATIONS

Model No.	Volt/Hz	Air Flow @0.1"SP (CFM)	Power @0.1"SP (W)	Max Current (Amps)	Weight (lb.)	LED Light Spec
ITG100ELED	120/60	100	17.0	0.47	8.2	13Watts 1000Lumens 3000K

Note: Design and specifications are subject to change without notice.

APPROVED BY



3/7/2024

Approval of this document does not authorize or approve any deviation or deviations from the requirements of applicable State Laws.

Kip Whitehead



FOUNDATION VENTS

Air Vent offers a complete line of foundation vents, from powered foundation vents to heavy-duty and replacement automatics. For all of your foundation ventilation needs call Customer Service: 1-800-247-8368.

Automatic Foundation Vents



**HEAVY-DUTY
MODEL: ST**

- Heavy-duty construction
- Premium bi-metal coil
- Honeycomb grill
- 5-year limited warranty
- NFA 50"
- Colors: black, brown, gray



**REPLACEMENT AUTOMATIC
MODEL: RA**

- Easy to install, includes hardware
- 3-year limited warranty
- NFA 50"
- Colors: black, brown, gray

Powered Foundation Vents



**HIGH POWER
MODEL: STP**

- For problem and hard to vent foundations
- Suctions air out of foundation
- .8 amp motor, 3000 rpm
- Colors: black, brown, gray

**QUIET MODEL
MODEL: STQ**

- .5 amp motor, 1550 rpm
- Colors: black, brown, gray

Accessories



**THERMOSTAT; HUMIDISTATS
HUMIDISTAT MODELS: HUB & HUC**

- Thermostat turns fan on when temperature exceeds setting
- HUB humidistat shuts the fan off in damp weather
- HUC humidistat turns on when humidity is above setting



Approval of this document does not authorize or approve any deviation or deviations from the requirements of applicable State Laws.
Kip Whitehead

Manual Foundation Vents – Plastic

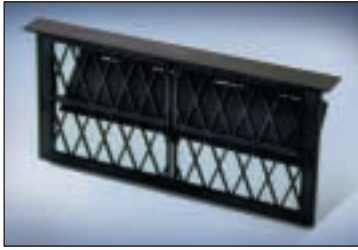

ACCORDION DAMPER
MODEL: 101

- Folding, accordion style damper
- NFA 68"
- Colors: black, brown, gray

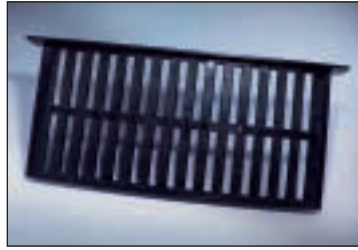

HEAVY-DUTY SLIDER
MODEL: 303

- Heavy-duty solid plastic construction
- Aluminum screen
- NFA 42"
- Colors: black, brown, gray



SLIDER - MODEL: PLSL
DAMPER - MODEL: PLDP

- Our best selling slider & damper
- Slider NFA 45"
- Damper NFA 64"
- Colors: black, brown, gray (Damper PLDP: black, gray)

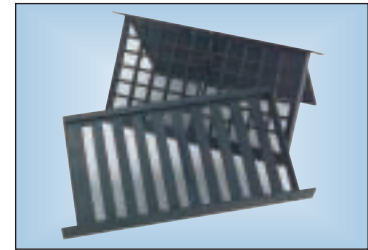

JUMBO VENTS
SLIDER - MODEL: JMSLBL
DAMPER - MODEL: JBDPBL

- Slider or Damper
- For 9¹/₄" x 16" opening
- NFA: slider 60"; damper 78"
- Courses out with oversized bricks
- Color: black

MULTI-PURPOSE VENT
MODEL: MP
(Not Shown)

- 7" x 12" vent for 6" x 11" opening
- NFA 23"
- Colors: black, brown, gray

Foundation ventilation helps protect against conditions that can lead to:

- Wood decay
- Mold and mildew
- Termite and insect infiltration

Significant damage can occur to a home without proper foundation ventilation:

Dark, damp environments attract wood attacking termites and other insects

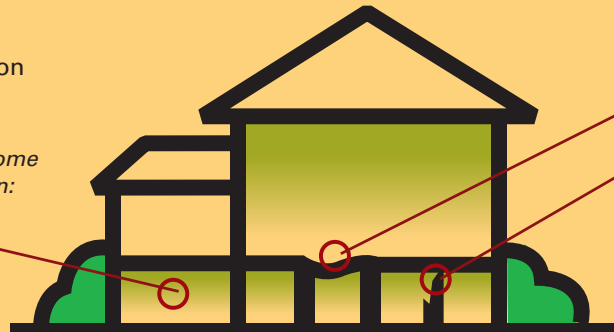

Floors can warp

Wood can decay causing structural damage

Manual Replacement



MANUAL REPLACEMENT
MODEL: RM

- Same housing as automatic
- Manual lever instead of automatic coil
- NFA 50"
- Colors: black, brown, gray

Manual Foundation Vents – Metal

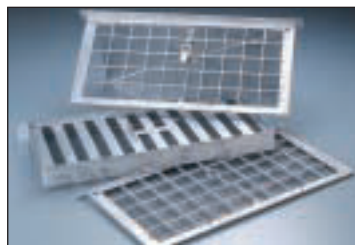

ALUMINUM FIXED VENTS
LINTEL - MODEL: FC3L
NO LINTEL - MODEL: FC3

- No damper or slider
- 16" x 8"
- Color: mill



STAMPED ALUMINUM
MODEL: FA109

- Aluminum screen
- Adjustable sliding damper
- Also available for wood
- NFA 36"

ALUMINUM SLIDER
MODEL: ALSL

- With lintel
- Color: mill
- NFA 45"

ALUMINUM DAMPERS
NO LINTEL - MODEL: FC
LINTEL - MODEL: ALDP

- Color: mill
- NFA 63"



3000 West Commerce
Dallas, TX 75212
1-800-AIRVENT
www.airvent.com

APPROVED BY



3/7/2024

Approval of this document does not authorize or approve any deviation or deviations from the requirements of applicable State Laws.

Kip Whitehead



©2004 Air Vent, Inc.
RAV065-6/04

AUTOMATIC VENT INSTALLATION INSTRUCTIONS

SERIES-5 2-PIECE VENT
WITH REMOVABLE FRAME

1. Remove the old vent with hammer and chisel, crow bar, etc., and clean protruding and loose mortar from opening with chisel. Vent MUST slide in easily. If it doesn't, use chisel to enlarge opening.

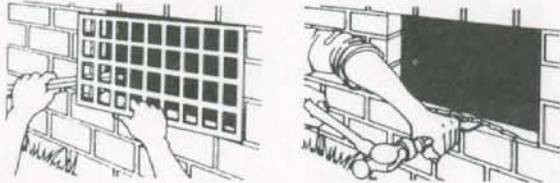

2. Remove frame from vent by pulling up or by inserting blade between frame and vent on outside and twisting. Be careful not to damage screen.

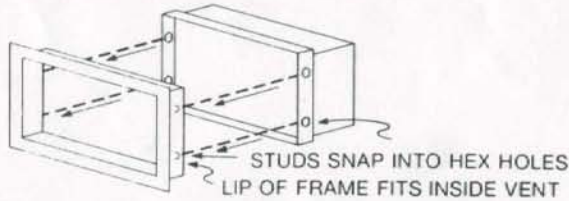

3. Attach a retaining spring to 2 opposite sides of the vent—either left and right or top and bottom depending on which produces the tighter fit in the foundation wall. Slide the barbed ends of the springs into the slots to attach.

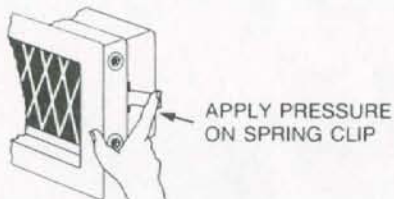
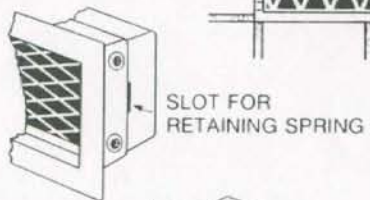
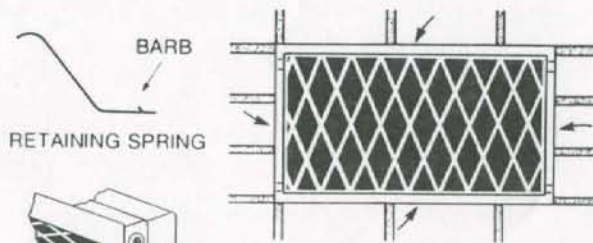

4. Insert vent into foundation opening either from the outside of the crawl space or from the inside. Be sure it fits easily. DO NOT USE FORCE. Hold TIGHTLY against the wall after adjusting for alignment. Using a 1/4" masonry carbide tipped bit, drill through the vent into a mortar joint on each side. It is best to drill high on one side and low on the other for increased stability. Be sure to line up with a mortar joint and angle the drill slightly inward toward the crawl space.

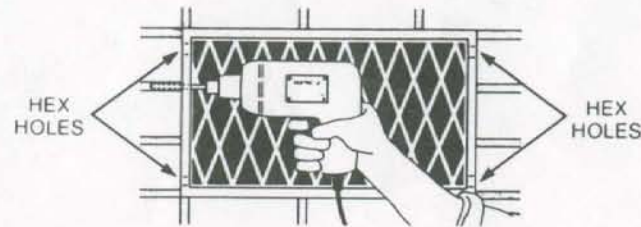

NOTE:

The most important part of the installation is to hold the vent TIGHTLY against the wall while the two holes are drilled. The vent must not be moved between drilling the first and second holes. Some installers insert a screw in the first hole to hold the vent steady while drilling the second.

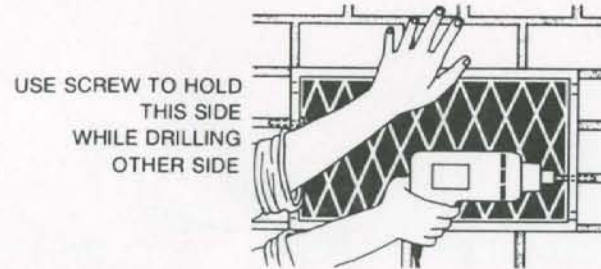

Be sure to drill the hole in the mortar joint deep enough the first time. Redrilling may make the hole too big for the anchor.

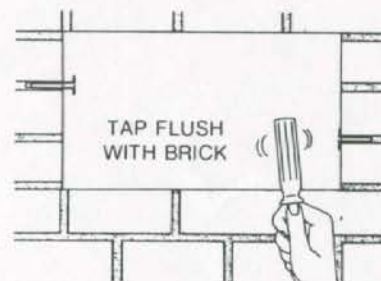

5. Remove the vent from the wall temporarily. Blow loose material out of the holes and insert the screw anchors. Tap the anchors all the way flush with the brick using a screw driver handle.

6. Mount vent using screws supplied. Turn screw until head is just flush with frame. Do not use excess pressure. To start the screw in the anchor it is helpful to bend the vent slightly away from the wall to see the tip of the screw enter the anchor. While turning the screw, if the vent begins to come away from the wall it means the screw is not in the anchor.

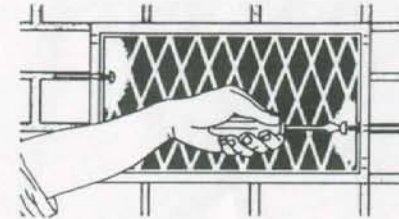

7. Before fully tightening the screws, adjust the vent left to right to insure that it is centered in the foundation opening.

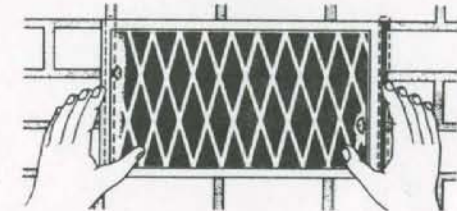

8. Replace the frame.

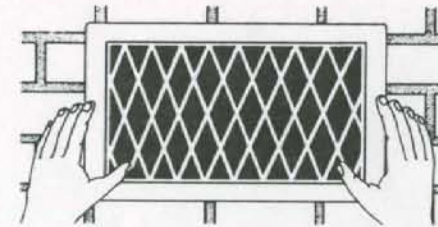

9. Using a wire which will pass through the screen, test for freedom of movement of the louvers to be sure there is no binding.

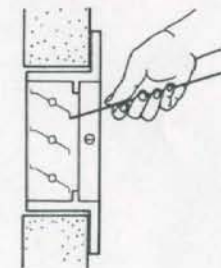

APPROVED BY

NIA

3/7/2024

Approval of this document does not authorize or approve any deviation or deviations from the requirements of applicable State Laws.

Kip Whitehead

TEMPA-VENT®

P.O. BOX 2030
SHELBY, N.C. 28150

NORTH CAROLINA
MODULAR PLANS REVIEW CHECKLIST

Page 1 of 3

Revised June 2018

Model Number/Name: #196763 Rescue Construction Clara "C" Model Home / Lot Model	
3rd Party: <u>NTA, Inc.</u>	
Review Date: _____	3/7/2024
Reviewer: _____	Kip Whitehead
	Plan Sheet Page No. and Notes
<u>QC MANUAL (Current and Complete)</u>	Yes
<u>Appendix B (Required and Attached)</u>	N / A
<u>PLAN SHEETS</u>	
Each plan sheet third-party stamped with approver's name	YES
Each plan sheet is numbered and/or indexed	YES
<u>GENERAL (Cover Sheet)</u>	
Code Reference	COVER SHEET - PAGE-1
Statement regarding connection to public utilities	COVER SHEET - PAGE-1
Statement regarding bathrooms if not included	COVER SHEET - PAGE-1
Construction type	COVER SHEET - PAGE-1
Occupancy classification	COVER SHEET - PAGE-1
Fire resistance ratings (if required)	COVER SHEET - PAGE-1
Floor live load	COVER SHEET - PAGE-1
Roof live load	COVER SHEET - PAGE-1
Design wind velocity	COVER SHEET - PAGE-1
Seismic information (commercial projects)	N / A
Thermal zones	COVER SHEET - PAGE-1
Notice to inspections department regarding items to be site inspected	COVER SHEET - PAGE-1
<u>FLOOR PLANS</u>	
Interior and exterior wall layouts	FLOOR PLAN - PAGE-3
Door and window schedule	DOOR & WINDOW SCHEDULE - PAGE-22
Light and ventilation requirements	FLOOR PLAN - PAGE-3
Attic access (size and location)	FLOOR PLAN - PAGE-3
Non-prescriptive headers	N / A
Safety glazing requirements	FLOOR PLAN - PAGE-3
Fire rating of Exterior walls (if applicable)	N / A
<u>EXTERIOR ELEVATIONS</u>	
Exterior materials	ELEVATION & SECTION -PAGE 6 & 21
Attic Ventilation requirements	ELEVATION - PAGE-6
<u>PLUMBING</u>	
Plan	FLOOR PLAN - PAGE-3
All fixtures furnished by manufacturing shown on plans	FLOOR PLAN - PAGE-3
Materials (water supply & distribution, DWV, storm drainage)	DWV PLAN - PAGE-11 & 12
Supply and waste risers	DWV PLAN - PAGE-11 & 12
Water heater (type and capacity) 50 Gallon Electric (Installed)	RISER DIAGRAM - PAGE-12
	50 of 52

NORTH CAROLINA
MODULAR PLANS REVIEW CHECKLIST

Page 2 of 3

Revised June 2018

<u>MECHANICAL</u>	
Design calculations	N / A
Installed unit capacity	N / A
Supply and returns (locations and sizes)	N / A
Duct sizes	N / A
Specifications (units, ducts)	N / A
All appliances furnished by mfg. shown on plans	FLOOR PLAN - PAGE- 3
<u>ELECTRICAL</u>	
Plan	ELECTRICAL PLAN - PAGE-9
Location of all electrical boxes	ELECTRICAL PLAN - PAGE-9
Electrical panel location	FLOOR PLAN & ELEC PAGE 3 & 9
Note regarding main disconnect (if applicable)	FLOOR PLAN & ELEC PAGE 3 & 9
Exterior lighting and receptacles	ELECTRICAL PLAN - PAGE-9
Ground level receptacles (if applicable)	FOUNDATION - PAGE-2
Smoke detector location(s)	ELECTRICAL PLAN - PAGE-9
Electical load calculations	ELECTRICAL CALCULATIONS - PAGE-23
Electrical panel layout (breaker and wire sizes, circuit schedules)	ELECTRICAL PLAN - PAGE-9
Panel and service entrance sizes	ELECTRICAL PLAN - PAGE-9
All fixtures furnished by mfg. shown on plans	ELECTRICAL PLAN - PAGE-9
<u>ACCESSIBILITY (for other than 1 & 2 family dwelling)</u>	
Entrances and means of egress	N / A
Doors, doorways, and door hardware	N / A
Stairs and handrails	N / A
Toilet rooms, plumbing fixtures, grab bars, etc.	N / A
Bathrooms and shower rooms	N / A
Occupancy specific requirements	N / A
Multi-family dwellings: Type A and B units	N / A
<u>FLOOR X-SECTION</u>	
Joists and beam sizes and spacing	SECTION - PAGE-21
Materials species and grade	SECTION - PAGE-21
Sheathing, decking, and concrete as applicable	SECTION - PAGE-21
Fastening instructions	SECTION - PAGE-21
Insulation	SECTION - PAGE-21
Details as required for clarification	SECTION - PAGE-21
<u>WALL X-SECTION</u>	
Stud and column sizes and spacing	SECTION - PAGE-21
Materials species and grade	SECTION - PAGE-21
Sheathing and bracing	SECTION - PAGE-21
Headers and lintels	SECTION - PAGE-21
Finishes	SECTION - PAGE-21
Fastening instructions	SECTION - PAGE-21
Insulation	SECTION - PAGE-21
Details as required for clarification	DETAIL PAGES: 4, 5, 13, 14, 15, 16, 17, 18, 19 & 20

NORTH CAROLINA
MODULAR PLANS REVIEW CHECKLIST

Page 3 of 3

Revised June 2018

<u>CEILING / ROOF X-SECTION</u>	
Truss, rafter, and beam spacing	SECTION - PAGE-21
Lumber species and grade	SECTION - PAGE-21
Sheathing and decking	SECTION - PAGE-21
Finishes	SECTION - PAGE-21
Fastening instructions	SECTION - PAGE-21
Insulation	SECTION - PAGE-21
Details including NC sealed truss designs or manual reference	CALCULATIONS MANUAL
<u>FOUNDATION PLAN</u>	
Footings, pier, and curtain wall locations and specifications	FOUNDATION - PAGE-2
X-sections with dimensions	FOUNDATION, SECTION - PAGE-2 & 21
Anchorage - sill plate to piers and curtain wall	COVER SHEET - PAGE-1
Anchorage - building to sill plate	FOUNDATION, SECTION - PAGE-2 & 21
Anchorage - tie downs (lateral and logitudinal)	FOUNDATION, SECTION - PAGE-2 & 21
Soil bearing capacity	COVER SHEET - PAGE-1
Minimum concrete compressive strength	FOUNDATION - PAGE-2
Mortar type	COVER SHEET - PAGE-1
Ventilation requirements (with and without vapor barrier)	FOUNDATION - PAGE-2
Crawl space access requirements	FOUNDATION - PAGE-2
<u>ENERGY COMPLIANCE</u>	
Demonstrated compliance	PRESCRIPTIVE PER CODE
<u>SET-UP INSTRUCTIONS</u>	
Floor and ceiling connections	PAGE 4 (OPERATIONS MANUAL)
Marriage wall connections	PAGE 4 (OPERATIONS MANUAL)
Roof set-up and connection	PAGE 6 (OPERATIONS MANUAL)
Plumbing connections	PAGE 33 (OPERATIONS MANUAL)
Mechanical connections	PAGE 34 (OPERATIONS MANUAL)
Electrical connections	PAGE 33 (OPERATIONS MANUAL)
Fire stopping	PAGE 4 (OPERATIONS MANUAL)
Air infiltration elimination	PAGE 4 (OPERATIONS MANUAL)
Notice to inspections department attachments if set-up instructions are by attachment	COVER SHEET - PAGE-1
<u>ITEMS NOT INSPECTED BY PLANT</u>	
List of items not inspected by 3rd. Party	COVER SHEET - PAGE-1
Notice to inspections department	COVER SHEET - PAGE-1