



Prepared by:
Page Brockman
page@regionalwaterproofing.com
Regional Foundation & Crawlspace Repair
www.regionalwaterproofing.com
TF 919-851-4500
F (919) 269-6788
License# 100348

Prepared for:
Kevin Nolan
knomad55@gmail.com
P (603) 534-5577

Job location:
139 Jacob St
Holly Springs, NC 27540

Prepared on:
6-18-24

Project Summary

Table with 2 columns: Item and Price. Items include My Crawl Space, Permanently Stabilize Floors, Permit, Engineering, Total Investment, Same Day Savings, Total Contract Price (\$19,893.47), Deposit Required - 30%, Deposit Paid, and Amount Due Upon Installation (\$13,925.43).

Customer Consent

Any alteration from the above specifications and corresponding price adjustment (if necessary) will be made only at the Customer's request or approval. Completing the work in this Proposal at the time scheduled is contingent upon accidents or delays beyond our control. This Proposal is based primarily on the Customer's description of the problem. Engineering services are used as required by companies such as SFA Engineering and other local Structural Engineering firms. This Proposal may be withdrawn if not accepted by the Customer within 20 days.

Authorized Signature: Page Brockman, Date: 6/18/2024

Acceptance of Contract— I am/we are aware of and agree to the contents of this Proposal, the attached Job Detail sheet(s), and the attached Limited Warranty, (together, the "Contract"). I am/ we are aware of and agree to the 60 day window that Regional has to remedy any service issues that are covered under the attached Limited Warranty. I will have bio-hazards cleaned and remediated that Regional may discover in the affected work area. This includes plumbing/sewage leaks, and any other hazards at my cost. I will provide documentation from a restoration company. You are authorized to do the work as specified in the Contract. However, field adjustments may be made if deemed vital by project Foreman or Production Manager. I/WE WILL MAKE THE PAYMENT TO CREW THE DAY PROJECT IS COMPLETED. MULTIPLE PHASE PROJECTS WILL BE INVOICED AND MUST BE PAID AT COMPLETION OF EACH PHASE.

Customer Signature: [Signature], Date: 6/18/2024. Includes initials and a signature box.

Customer to have financing in place two weeks before start of project.
Customer understands after three days all deposits are final.

Job Details

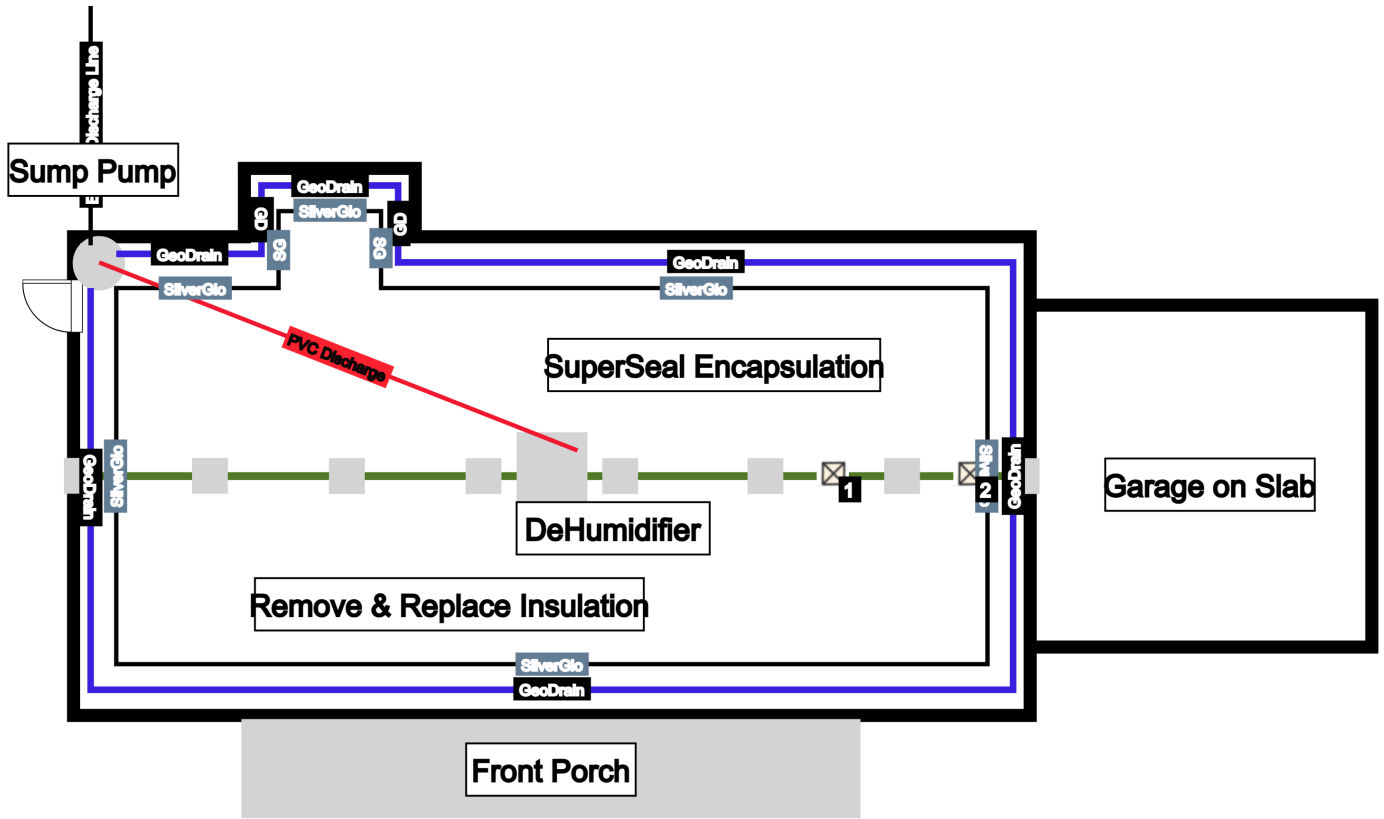

Type of Wall Block
Existing Wall Finish Plain
Existing Floor Finish Dirt

Job Details (Continued)

Specifications

1) Install SmartJack supports as indicated on job drawing to support the floor joist system above. Load Bearing utilizes a custom precast concrete footing on engineering fill. 2) Install exterior discharge line as shown on drawing 3) Complete enrollment in Customer Care program. Includes free annual maintenance and service call trip fees. Sump pumps and dehumidifiers will have lifetime warranties after one year enrollment in program (equipment must be good working order to enroll). Adjustments on SmartJacks, PowerBraces, and Wall Anchors are also included in this program. Enrollees also qualify for special pricing on future projects from Regional. 4) Two Dedicated Electrical Circuits and outlets with GFI protection 5) Install Geo Drain as indicated on the drawing. 6) Install an Everlast door, crawl space door. 7) Install SuperSeal as shown. 8) Install Aprilaire e100 as shown. 9) Install 1.5 inch pvc plumbing from sump pump to location of the discharge line. 10) Install SilverGlo high performance graphite insulation as indicated on job drawing. 11) Remove and dispose of existing insulation. 12) Obtain proper building permit. 13) Required Engineering for permitting documents and Letter of Completion.

Contractor Will

- 1.) Permit Project.
- 2.) Contact utility locator service

Customer Will

- 1.) Move items at least 10 feet away from the work area.
- 2.) Mark any private lines that may be hidden underground, and assumes all liability if damage should occur to such lines.
- 3.) Make payment of remaining balance to foreman of crew the same day installation is complete.

Additional Notes

All recommendations are based on customers descriptions of the problem. While inspection tools such as hygrometers and laser levels are used, no deconstruction or original house plans are available to review for the recommendation. Some unforeseen factors may impact project, despite best inspectors best efforts.

Product List

My Crawl Space

Exterior Discharge Line	10 ft
Customer Care Program	1
Electrical 2 Circuits, Electric	1
Geo Drain	170 Linear Foot
Everlast Door	1
SuperSeal, Encapsulation	1570
E100 Crawlspace Air System, Dehumidification	1
Interior PVC Discharge Extension	25 Linear Foot
SilverGlo	600 sqft
Insulation - Remove , Prevent Mold, Rot and Odors	1570 Square Foot

Permanently Stabilize Floors

Smart Jack 1'-3' (Load Bearing)	2
---------------------------------------	---

Permit

Permit Fee	1
------------------	---

Engineering

Standard Engineering Package , Engineering	1
--	---