



Carter Sanford Component Plant  
298 Harvey Faulk Rd  
Sanford, NC 27332

Phone #:919-775-1450



**Builder: Eric Boyer**

**Model: Eric Boyer**

THE PLACEMENT PLAN NOTES:

1. The Placement Plan is a diagram for truss installation. It is not an engineered drawing and has not been reviewed by an engineer. The Owner/Building Designer is responsible for obtaining an engineer's review if one is required by the local jurisdiction.
2. The responsibilities of the Owner, Contractor, Building Designer, Component Designer and Component Manufacturer shall be as set forth in ANSI/TPI 1. Capitalized terms shall be as defined in ANSI/TP 1 unless otherwise indicated.
3. Each Component is designed as an individual component utilizing information provided by others. The Owner/Building Designer is responsible for reviewing all Component Submittal Packages and individual Component Design Drawings for compliance with the Construction Documents and compatibility with the overall Building design.
4. Contractor will not proceed with component installation until the Owner/Building Designer has reviewed the Component Submittal Package. Questions on the suitability of any Component will be resolved by the Building Designer.
5. The Building Designer and Contractor are responsible for all temporary and permanent bracing.
6. The Placement Plan assumes the building is dimensionally correct, structurally sound, and in a suitable condition to support each Component during installation and thereafter, including but not limited to installation of all bearing points. Proper design and construction of all structural components, including foundations, headers, beams, walls and columns are the responsibility of the Owner, Building Designer and Contractor.
7. Do not cut, drill, or modify any Component without first consulting the Component Manufacturer or Building Designer. Damaged Components shall not be installed unless directed by the Building Designer or approved by the Component Manufacturer.
8. Components must be handled and installed following all applicable safety standards and best practices, including but not limited to BCSI, OSHA, TPI and local codes. Failure to properly handle, brace or otherwise install Component can result in serious injury or death.
9. All uplift connectors shown within these documents are recommendations only. Per ANSI/TPI 1, all uplift connectors are the responsibility of the building designer and or contractor.

Approved By: \_\_\_\_\_

Date: \_\_\_\_\_

**General Notes:**

\*\* CUTTING OR DRILLING OF COMPONENTS SHOULD NOT BE DONE WITHOUT CONTACTING COMPONENT SUPPLIER FIRST. CUSTOMER TAKES FULL RESPONSIBILITY FOR COMPONENTS IF CUT BEFORE AUTHORIZATION.

\*\* ALL BEARING POINTS MUST BE INSTALLED PRIOR TO SETTING ANY COMPONENTS.

Revisions	
00/00/00	Name
00/00/00	Name
00/00/00	Name
00/00/00	Name
00/00/00	Name

**THIS IS A TRUSS PLACEMENT DIAGRAM ONLY.** These trusses are designed as individual components to be incorporated into the building design at the specification of the building designer. See individual design sheets for each truss design identified on the placement drawing. The building designer is responsible for temporary and permanent bracing of the roof and floor systems and for the overall structure. The design of the truss support structure including headers, beams, walls, and columns is the responsibility of the building designer. For general guidance regarding the bracing, consult "Bracing of Wood Trusses" available from the Truss Plate Institute, 583 D'Onofrio Drive, Madison, WI 53179



Eric Boyer  
Eric Boyer Quote  
**ROOF PLACEMENT PLAN**

Scale: NTS  
Date: 5/13/2024  
Designer: Nathan Clarke  
Project Number: 24050043  
Sheet Number:

1/1

\*\* FRAMER MUST REFER TO PLANS WHILE SETTING COMPONENTS. \*\* DAMAGED COMPONENTS SHOULD NOT BE INSTALLED UNLESS TOLD TO BY THE COMPONENT PLANT. \*\* TRUSS TO TRUSS CONNECTIONS ARE TOE-NAILED, UNLESS NOTED OTHERWISE.

\*\* GIRDERS MUST BE FULLY CONNECTED TOGETHER PRIOR TO ADDING ANY LOADS. \*\* DIMENSIONS ARE READ AS: FOOT-INCH-SIXTEENTH. \*\* All uplift connectors shown within these documents are recommendations only. Per ANSIT/TP1, all uplift connectors are the responsibility of the bldg designer and/or contractor.

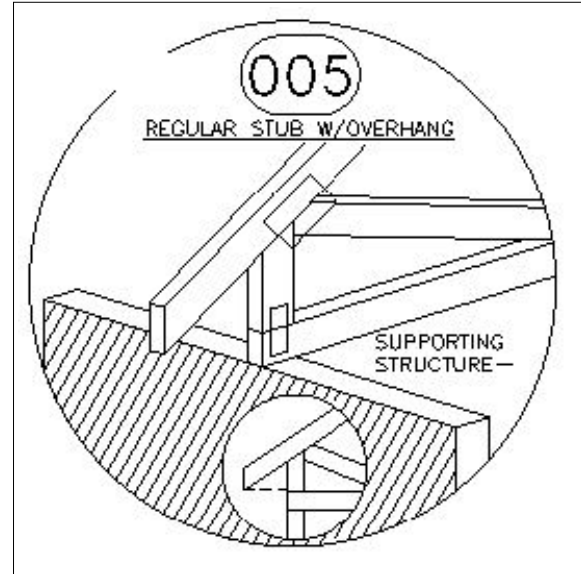
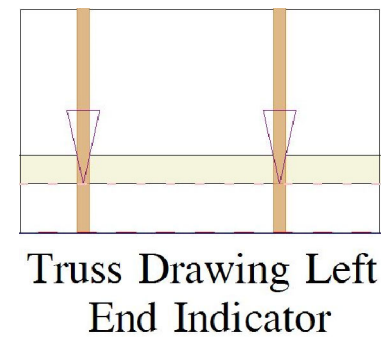
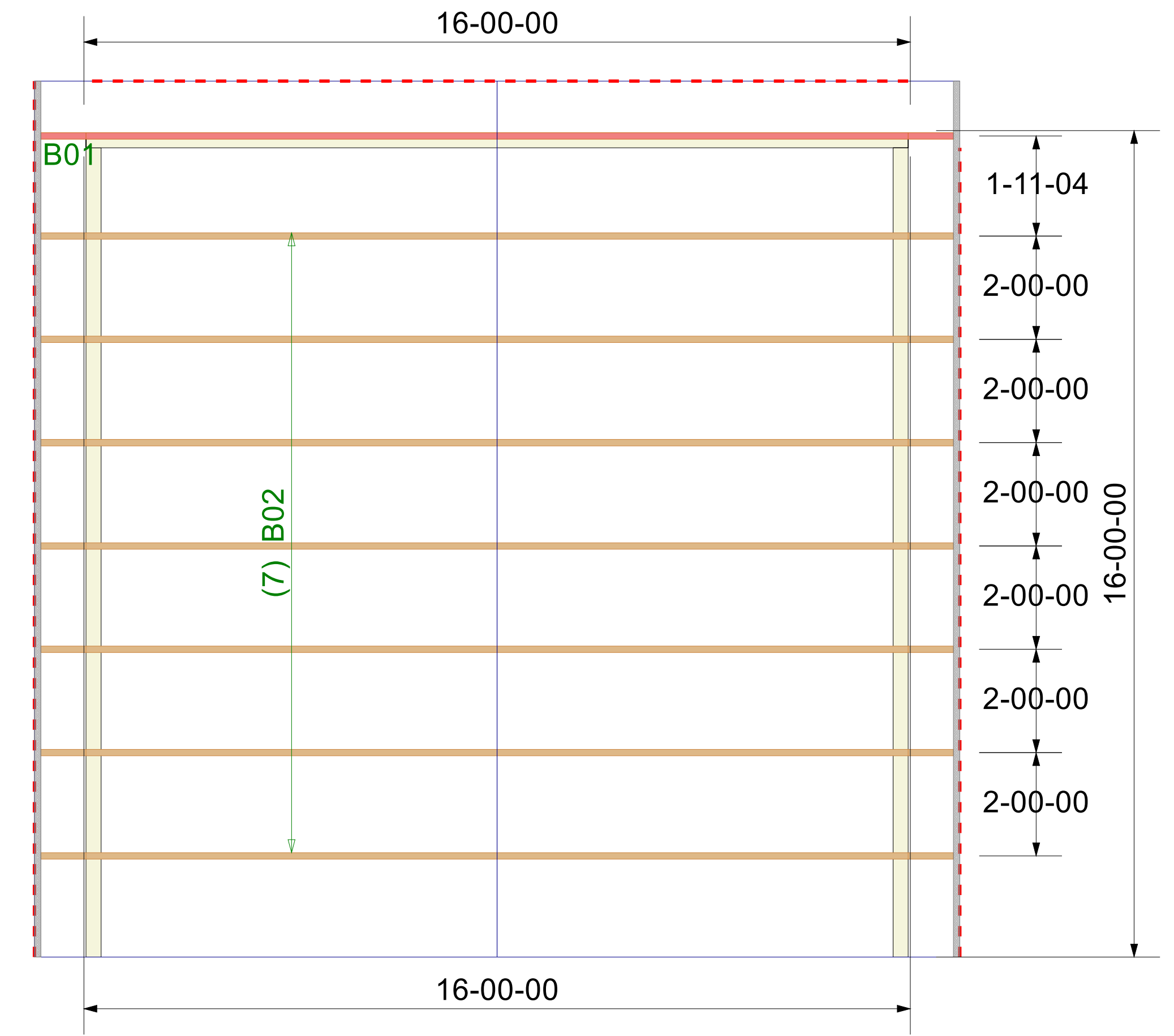
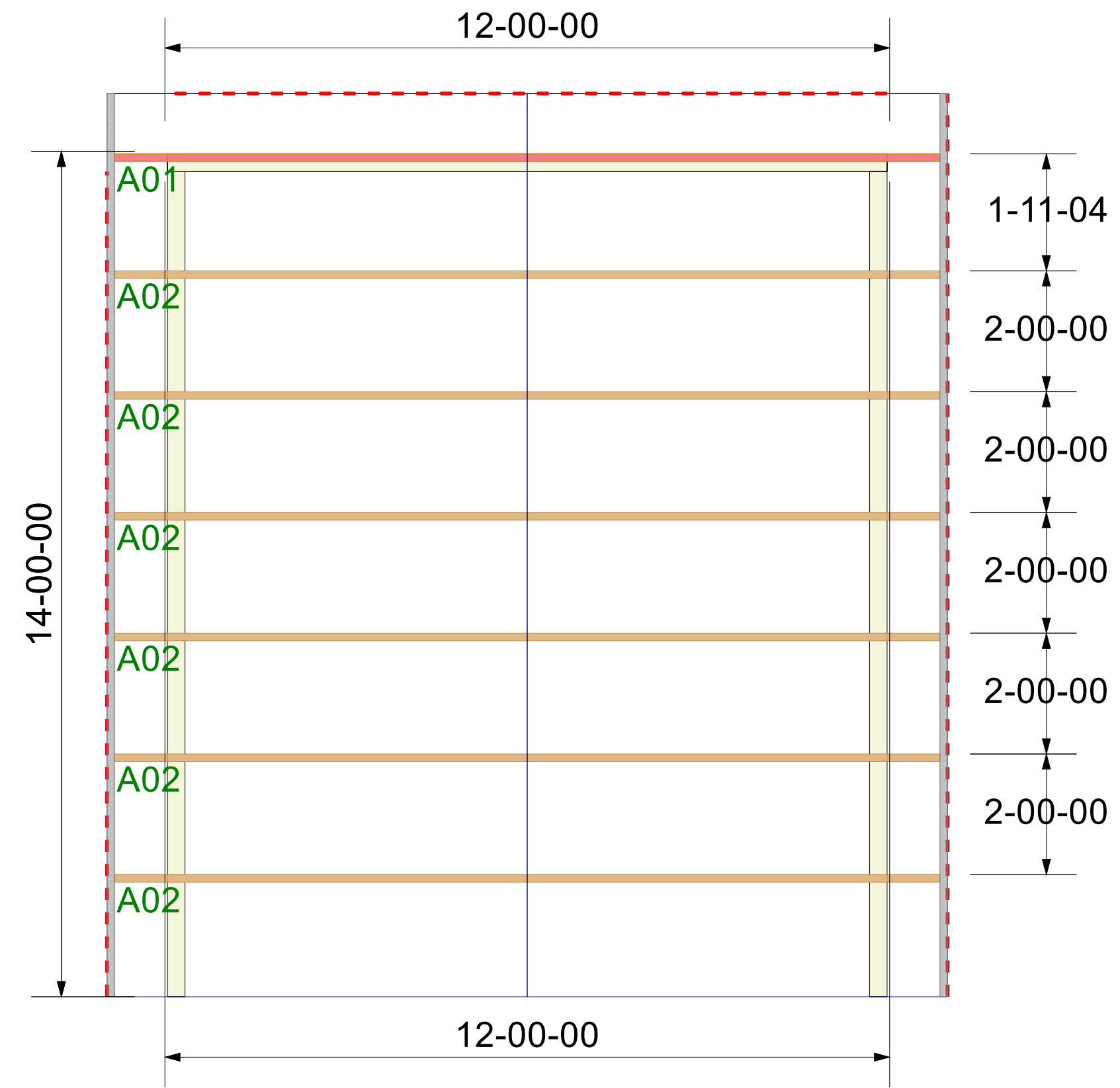
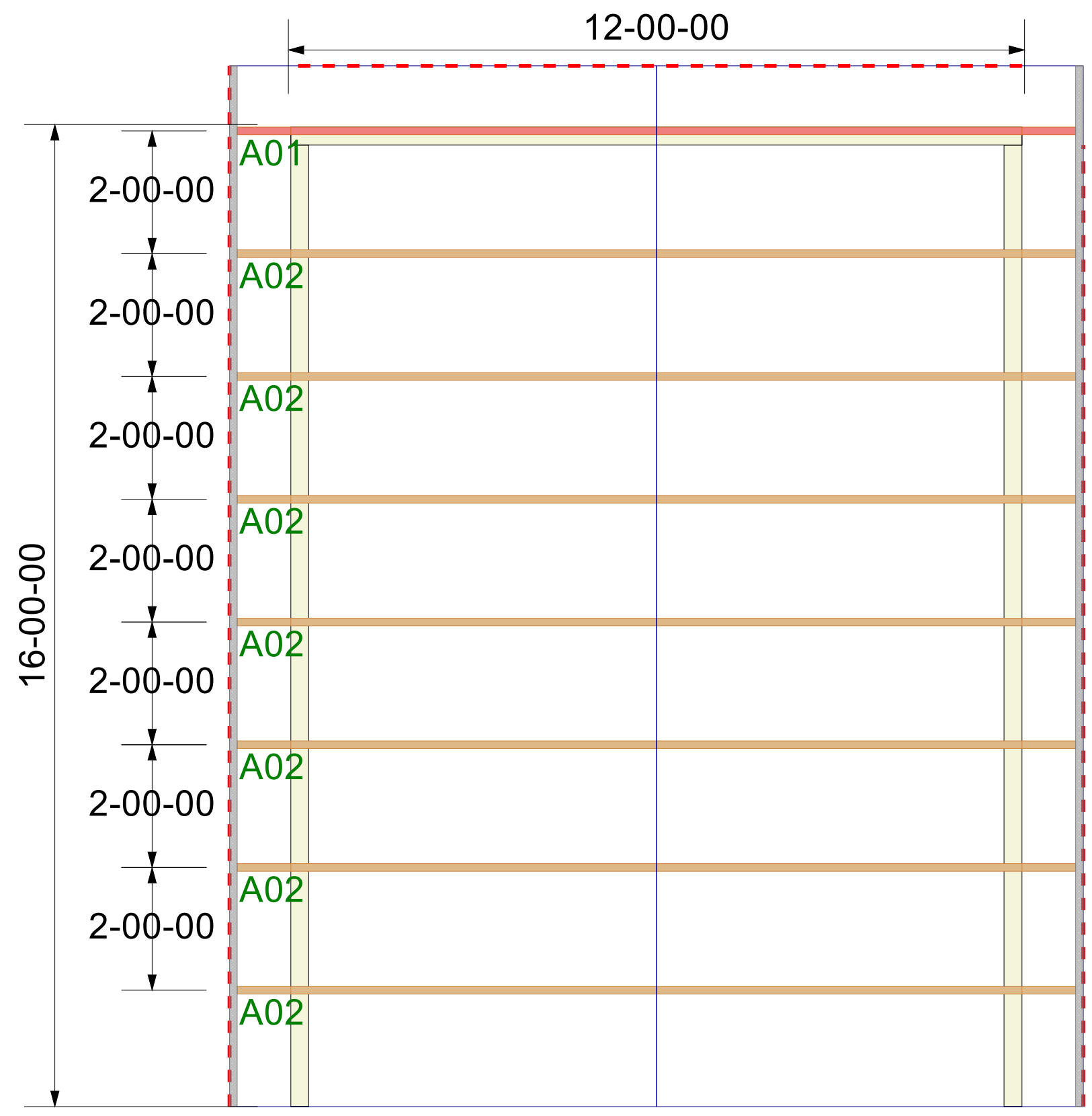

\*\* TRIANGULAR SYMBOL NEAR END OF TRUSS INDICATES LEFT END OF TRUSS AS SHOWN ON INDIVIDUAL TRUSS DRAWINGS.

\*\* PLUMBING DROPS NOTED ARE IN THE APPROXIMATE LOCATIONS PER PLAN. BUILDER TO VERIFY LOCATIONS BEFORE SETTING TRUSSES.

\*\* REFER TO FINAL TRUSS ENGINEERING SHEETS FOR PLY TO PLY CONNECTIONS.

Trenco  
818 Soundside Rd  
Edenton, NC 27932

Re: 24050043-01  
72 Crown-Eric Boyer-Roof-Eric Boyer

The truss drawing(s) referenced below have been prepared by Truss Engineering Co. under my direct supervision based on the parameters provided by Carter Components (Sanford, NC)).

Pages or sheets covered by this seal: I65814893 thru I65814896

My license renewal date for the state of North Carolina is December 31, 2024.

North Carolina COA: C-0844



May 24, 2024

Gilbert, Eric

**IMPORTANT NOTE:** The seal on these truss component designs is a certification that the engineer named is licensed in the jurisdiction(s) identified and that the designs comply with ANSI/TPI 1. These designs are based upon parameters shown (e.g., loads, supports, dimensions, shapes and design codes), which were given to MiTek or TRENCO. Any project specific information included is for MiTek's or TRENCO's customers file reference purpose only, and was not taken into account in the preparation of these designs. MiTek or TRENCO has not independently verified the applicability of the design parameters or the designs for any particular building. Before use, the building designer should verify applicability of design parameters and properly incorporate these designs into the overall building design per ANSI/TPI 1, Chapter 2.

Job 24050043-01	Truss A01	Truss Type Common Supported Gable	Qty 2	Ply 1	72 Crown-Eric Boyer-Roof-Eric Boyer Job Reference (optional)	165814893
--------------------	--------------	--------------------------------------	----------	----------	---	-----------

Carter Components (Sanford, NC), Sanford, NC - 27332,

Run: 8.73 S Apr 25 2024 Print: 8.730 S Apr 25 2024 MiTek Industries, Inc. Fri May 24 08:49:35  
ID:3f31FP1iS0tQh08bqaOXYzIs57-RfC?PsB70Hq3NSgPqnL8w3uITXbGKwRCDoi7J4zJC?f

Page: 1

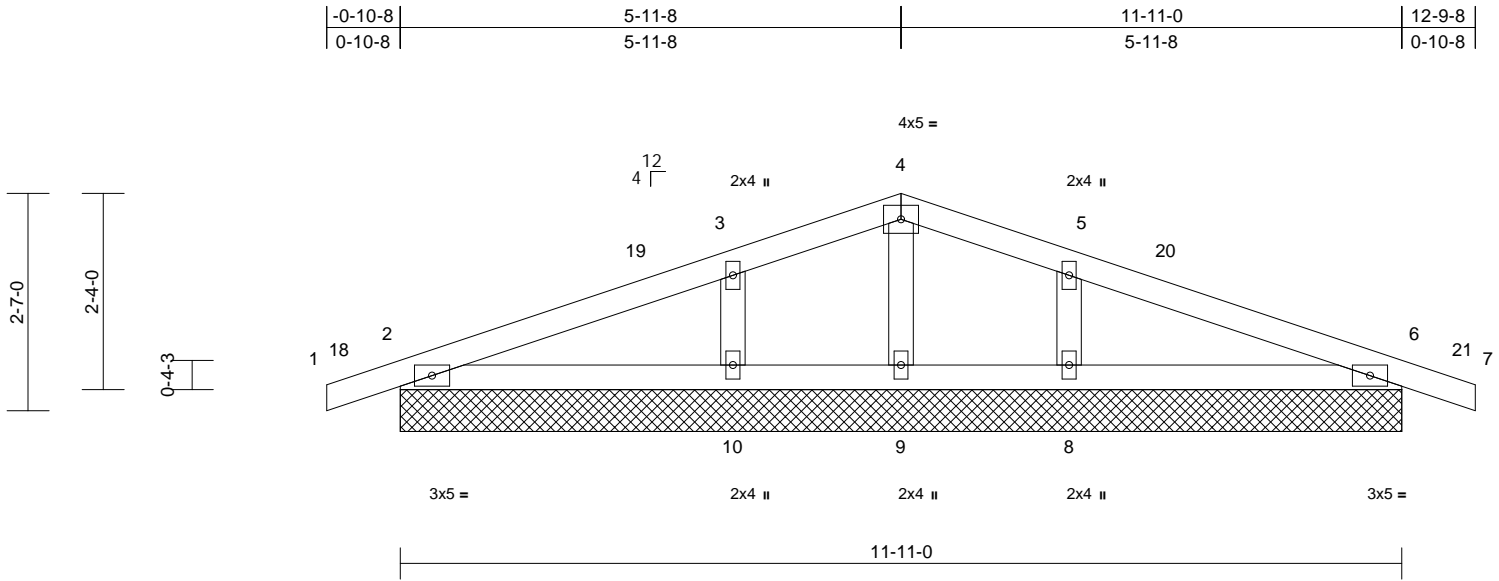

Scale = 1:27.4

Loading	(psf)	Spacing	1-11-4	CSI	DEFL	in	(loc)	l/defl	L/d	PLATES	GRIP	
TCLL (roof)	20.0	Plate Grip DOL	1.15	TC	0.20	Vert(LL)	n/a	-	n/a	999	MT20	244/190
Snow (Pf)	20.0	Lumber DOL	1.15	BC	0.18	Vert(CT)	n/a	-	n/a	999		
TCDL	10.0	Rep Stress Incr	YES	WB	0.06	Horz(CT)	0.00	2	n/a	n/a		
BCLL	0.0*	Code	IRC2018/TPI2014	Matrix-MSH								
BCDL	10.0											
											Weight: 45 lb	FT = 20%

**LUMBER**  
TOP CHORD 2x4 SP No.2  
BOT CHORD 2x4 SP No.2  
OTHERS 2x4 SP No.3

**BRACING**  
TOP CHORD Structural wood sheathing directly applied or 6-0-0 oc purlins.  
BOT CHORD Rigid ceiling directly applied or 10-0-0 oc bracing.

**REACTIONS** (size)  
2=11-11-0, 6=11-11-0, 8=11-11-0, 9=11-11-0, 10=11-11-0, 11=11-11-0, 15=11-11-0  
Max Horiz 2=-35 (LC 15), 11=-35 (LC 15)  
Max Uplift 2=-52 (LC 10), 6=-57 (LC 11), 8=-63 (LC 15), 10=-64 (LC 14), 11=-52 (LC 10), 15=-57 (LC 11)  
Max Grav 2=254 (LC 21), 6=254 (LC 22), 8=424 (LC 22), 9=30 (LC 15), 10=424 (LC 21), 11=254 (LC 21), 15=254 (LC 22)

**FORCES** (lb) - Maximum Compression/Maximum Tension  
TOP CHORD 1-2=0/21, 2-3=-72/39, 3-4=-67/113, 4-5=-67/113, 5-6=-72/39, 6-7=0/21  
BOT CHORD 2-10=-5/58, 9-10=0/39, 8-9=0/39, 6-8=0/58  
WEBS 4-9=-35/9, 3-10=-303/209, 5-8=-303/209

**NOTES**  
1) Unbalanced roof live loads have been considered for this design.

- Wind: ASCE 7-16; Vult=130mph (3-second gust) Vasd=103mph; TCDL=6.0psf; BCDL=6.0psf; h=25ft; Cat. II; Exp B; Enclosed; MWFRS (envelope) exterior zone and C-C Corner(3E) -0-10-8 to 2-1-8, Exterior(2N) 2-1-8 to 2-11-8, Corner(3R) 2-11-8 to 8-11-8, Exterior(2N) 8-11-8 to 9-9-8, Corner(3E) 9-9-8 to 12-9-8 zone; cantilever left and right exposed ; end vertical left and right exposed;C-C for members and forces & MWFRS for reactions shown; Lumber DOL=1.60 plate grip DOL=1.60
- Truss designed for wind loads in the plane of the truss only. For studs exposed to wind (normal to the face), see Standard Industry Gable End Details as applicable, or consult qualified building designer as per ANSI/TPI 1.
- TCLL: ASCE 7-16; Pr=20.0 psf (roof LL: Lum DOL=1.15 Plate DOL=1.15); Pf=20.0 psf (Lum DOL=1.15 Plate DOL=1.15); Is=1.0; Rough Cat B; Fully Exp.; Ce=0.9; Cs=1.00; Ct=1.10
- Unbalanced snow loads have been considered for this design.
- This truss has been designed for greater of min roof live load of 12.0 psf or 1.00 times flat roof load of 20.0 psf on overhangs non-concurrent with other live loads.
- Gable requires continuous bottom chord bearing.
- Gable studs spaced at 2-0-0 oc.
- This truss has been designed for a 10.0 psf bottom chord live load nonconcurrent with any other live loads.
- \* This truss has been designed for a live load of 20.0psf on the bottom chord in all areas where a rectangle 3-06-00 tall by 2-00-00 wide will fit between the bottom chord and any other members.
- Provide mechanical connection (by others) of truss to bearing plate capable of withstanding 52 lb uplift at joint 2, 57 lb uplift at joint 6, 64 lb uplift at joint 10, 63 lb uplift at joint 8, 52 lb uplift at joint 2 and 57 lb uplift at joint 6.
- This truss is designed in accordance with the 2018 International Residential Code sections R502.11.1 and R802.10.2 and referenced standard ANSI/TPI 1.

**LOAD CASE(S)** Standard



May 24, 2024

**WARNING - Verify design parameters and READ NOTES ON THIS AND INCLUDED MITEK REFERENCE PAGE MII-7473 rev. 1/2/2023 BEFORE USE.**

Design valid for use only with MiTek® connectors. This design is based only upon parameters shown, and is for an individual building component, not a truss system. Before use, the building designer must verify the applicability of design parameters and properly incorporate this design into the overall building design. Bracing indicated is to prevent buckling of individual truss web and/or chord members only. Additional temporary and permanent bracing is always required for stability and to prevent collapse with possible personal injury and property damage. For general guidance regarding the fabrication, storage, delivery, erection and bracing of trusses and truss systems, see **ANSI/TPI1 Quality Criteria and DSB-22** available from Truss Plate Institute (www.tpinst.org) and **BCSI Building Component Safety Information** available from the Structural Building Component Association (www.sbcacomponents.com)



818 Soundside Road  
Edenton, NC 27932

Job 24050043-01	Truss A02	Truss Type Common	Qty 13	Ply 1	72 Crown-Eric Boyer-Roof-Eric Boyer Job Reference (optional)	165814894
--------------------	--------------	----------------------	-----------	----------	---	-----------

Carter Components (Sanford, NC), Sanford, NC - 27332,

Run: 8.73 S Apr 25 2024 Print: 8.730 S Apr 25 2024 MiTek Industries, Inc. Fri May 24 08:49:36  
ID:nag4Lq8\_5S7?uwvWkwmlxfzls4z-RfC?PsB70Hq3NSgPqnL8w3uITXbGKwRCDoi7J4zJC?f

Page: 1

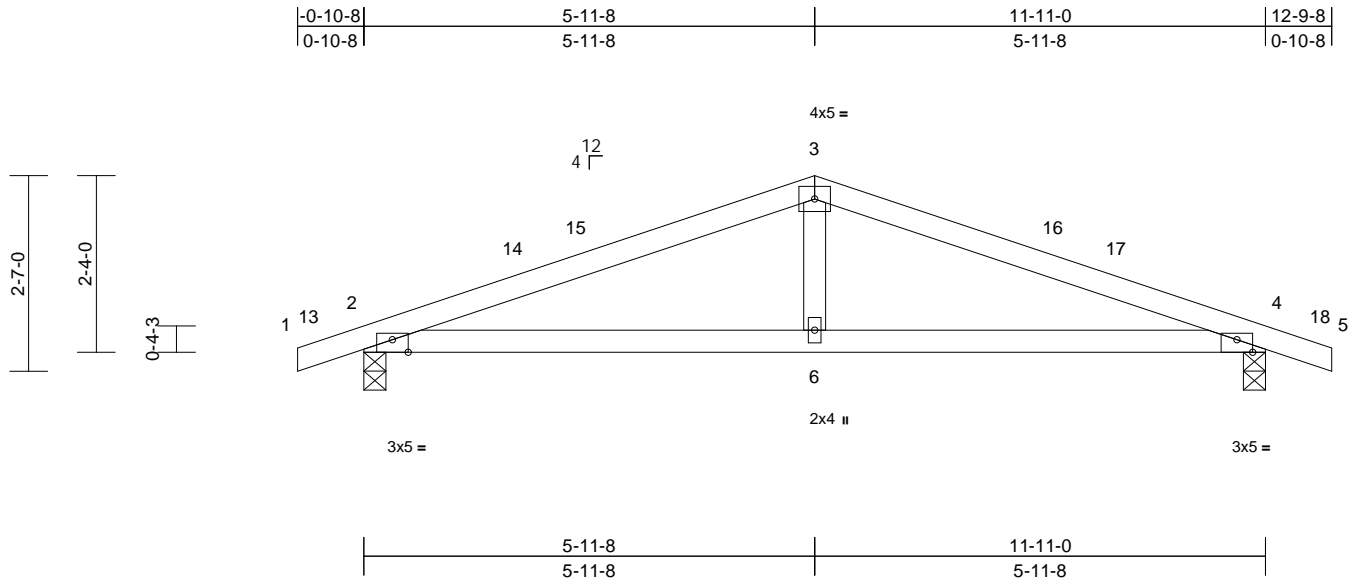

Scale = 1:30.4

Plate Offsets (X, Y): [2:0-2-8,Edge], [4:0-2-8,Edge]

Loading	(psf)	Spacing	2-0-0	CSI	DEFL	in	(loc)	l/defl	L/d	PLATES	GRIP
TCLL (roof)	20.0	Plate Grip DOL	1.15	TC	Vert(LL)	-0.08	6-9	>999	240	MT20	244/190
Snow (Pf)	20.0	Lumber DOL	1.15	BC	Vert(CT)	-0.12	6-9	>999	180		
TCDL	10.0	Rep Stress Incr	YES	WB	Horz(CT)	0.01	4	n/a	n/a		
BCLL	0.0*	Code	IRC2018/TPI2014	Matrix-MSH							
BCDL	10.0									Weight: 42 lb	FT = 20%

**LUMBER**

TOP CHORD 2x4 SP No.2  
BOT CHORD 2x4 SP No.2  
WEBS 2x4 SP No.3

**BRACING**

TOP CHORD Structural wood sheathing directly applied or 4-7-3 oc purlins.  
BOT CHORD Rigid ceiling directly applied or 10-0-0 oc bracing.

**REACTIONS**

(size) 2=0-3-8, 4=0-3-8  
Max Horiz 2=-36 (LC 15)  
Max Uplift 2=-89 (LC 10), 4=-89 (LC 11)  
Max Grav 2=635 (LC 21), 4=635 (LC 22)

**FORCES**

(lb) - Maximum Compression/Maximum Tension  
TOP CHORD 1-2=0/22, 2-3=-920/411, 3-4=-920/411, 4-5=0/22  
BOT CHORD 2-6=-290/831, 4-6=-290/831  
WEBS 3-6=0/272

**NOTES**

- Unbalanced roof live loads have been considered for this design.
- Wind: ASCE 7-16; Vult=130mph (3-second gust) Vasd=103mph; TCDL=6.0psf; BCDL=6.0psf; h=25ft; Cat. II; Exp B; Enclosed; MWFRS (envelope) exterior zone and C-C Exterior(2E) 0-10-8 to 2-1-8, Interior (1) 2-1-8 to 2-11-8, Exterior(2R) 2-11-8 to 8-11-8, Interior (1) 8-11-8 to 9-9-8, Exterior(2E) 9-9-8 to 12-9-8 zone; cantilever left and right exposed; end vertical left and right exposed; C-C for members and forces & MWFRS for reactions shown; Lumber DOL=1.60 plate grip DOL=1.60
- TCLL: ASCE 7-16; Pr=20.0 psf (roof LL: Lum DOL=1.15 Plate DOL=1.15); Pf=20.0 psf (Lum DOL=1.15 Plate DOL=1.15); Is=1.0; Rough Cat B; Fully Exp.; Ce=0.9; Cs=1.00; Ct=1.10

- Unbalanced snow loads have been considered for this design.
- This truss has been designed for greater of min roof live load of 12.0 psf or 1.00 times flat roof load of 20.0 psf on overhangs non-concurrent with other live loads.
- This truss has been designed for a 10.0 psf bottom chord live load nonconcurrent with any other live loads.
- \* This truss has been designed for a live load of 20.0psf on the bottom chord in all areas where a rectangle 3-06-00 tall by 2-00-00 wide will fit between the bottom chord and any other members.
- One H2.5A Simpson Strong-Tie connectors recommended to connect truss to bearing walls due to UPLIFT at jt(s) 2 and 4. This connection is for uplift only and does not consider lateral forces.
- This truss is designed in accordance with the 2018 International Residential Code sections R502.11.1 and R802.10.2 and referenced standard ANSI/TPI 1.

**LOAD CASE(S)** Standard

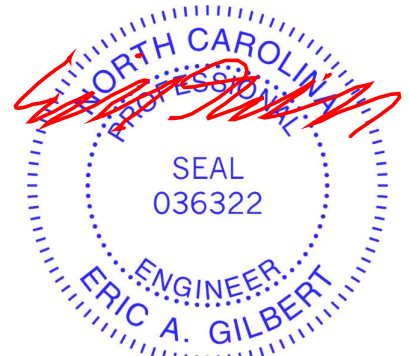

May 24, 2024

**WARNING - Verify design parameters and READ NOTES ON THIS AND INCLUDED MITEK REFERENCE PAGE MII-7473 rev. 1/2/2023 BEFORE USE.**

Design valid for use only with MiTek® connectors. This design is based only upon parameters shown, and is for an individual building component, not a truss system. Before use, the building designer must verify the applicability of design parameters and properly incorporate this design into the overall building design. Bracing indicated is to prevent buckling of individual truss web and/or chord members only. Additional temporary and permanent bracing is always required for stability and to prevent collapse with possible personal injury and property damage. For general guidance regarding the fabrication, storage, delivery, erection and bracing of trusses and truss systems, see **ANSI/TPI Quality Criteria and DSB-22** available from Truss Plate Institute (www.tpinst.org) and **BCSI Building Component Safety Information** available from the Structural Building Component Association (www.sbcacomponents.com)



818 Soundside Road  
Edenton, NC 27932

Job 24050043-01	Truss B01	Truss Type Common Supported Gable	Qty 1	Ply 1	72 Crown-Eric Boyer-Roof-Eric Boyer Job Reference (optional)	165814895
--------------------	--------------	--------------------------------------	----------	----------	---	-----------

Carter Components (Sanford, NC), Sanford, NC - 27332,

Run: 8.73 S Apr 25 2024 Print: 8.730 S Apr 25 2024 MiTek Industries, Inc. Fri May 24 08:49:36  
ID:4wbkpDENS00E?xseuOOj8zIs4s-RfC?PsB70Hq3NSgPqnL8w3uITXbGKwRcDoi7J4zJC7f

Page: 1

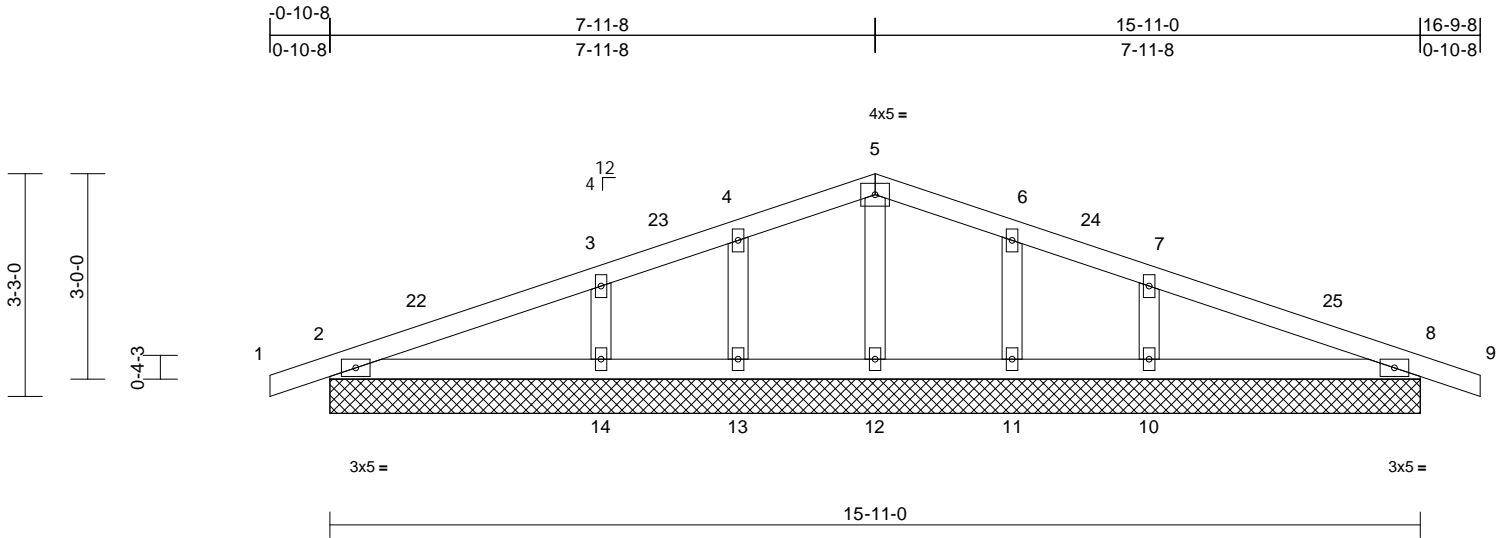

Loading	(psf)	Spacing	1-11-4	CSI	DEFL	in	(loc)	l/defl	L/d	PLATES	GRIP	
TCLL (roof)	20.0	Plate Grip DOL	1.15	TC	0.18	Vert(LL)	n/a	-	n/a	999	MT20	244/190
Snow (Pf)	20.0	Lumber DOL	1.15	BC	0.17	Vert(CT)	n/a	-	n/a	999		
TCDL	10.0	Rep Stress Incr	YES	WB	0.06	Horz(CT)	0.00	8	n/a	n/a		
BCLL	0.0*	Code	IRC2018/TPI2014	Matrix-MSH								
BCDL	10.0											
											Weight: 64 lb	FT = 20%

**LUMBER**  
TOP CHORD 2x4 SP No.2  
BOT CHORD 2x4 SP No.2  
OTHERS 2x4 SP No.3

**BRACING**  
TOP CHORD Structural wood sheathing directly applied or 6-0-0 oc purlins.  
BOT CHORD Rigid ceiling directly applied or 10-0-0 oc bracing.

**REACTIONS** (size)  
2=15-11-0, 8=15-11-0, 10=15-11-0,  
11=15-11-0, 12=15-11-0,  
13=15-11-0, 14=15-11-0,  
15=15-11-0, 19=15-11-0  
Max Horiz 2=-45 (LC 15), 15=-45 (LC 15)  
Max Uplift 2=-49 (LC 10), 8=-55 (LC 11),  
10=-61 (LC 15), 11=-26 (LC 11),  
13=-26 (LC 10), 14=-62 (LC 14),  
15=-49 (LC 10), 19=-55 (LC 11)  
Max Grav 2=206 (LC 21), 8=206 (LC 22),  
10=396 (LC 22), 11=145 (LC 22),  
12=158 (LC 22), 13=145 (LC 21),  
14=396 (LC 21), 15=206 (LC 21),  
19=206 (LC 22)

**FORCES** (lb) - Maximum Compression/Maximum Tension  
TOP CHORD 1-2=0/16, 2-3=-60/37, 3-4=-61/76,  
4-5=-56/113, 5-6=-56/113, 6-7=-61/76,  
7-8=-60/29, 8-9=0/16  
BOT CHORD 2-14=-6/49, 13-14=0/43, 12-13=0/43,  
11-12=0/43, 10-11=0/43, 8-10=0/49  
WEBS 5-12=-105/27, 4-13=-141/95, 3-14=-284/144,  
6-11=-141/95, 7-10=-284/144

**NOTES**  
1) Unbalanced roof live loads have been considered for this design.

- Wind: ASCE 7-16; Vult=130mph (3-second gust) Vasd=103mph; TCDL=6.0psf; BCDL=6.0psf; h=25ft; Cat. II; Exp B; Enclosed; MWFRS (envelope) exterior zone and C-C Corner(3E) -0-10-8 to 2-1-8, Exterior(2N) 2-1-8 to 4-11-8, Corner(3R) 4-11-8 to 10-11-8, Exterior(2N) 10-11-8 to 13-9-8, Corner(3E) 13-9-8 to 16-9-8 zone; cantilever left and right exposed; end vertical left and right exposed; C-C for members and forces & MWFRS for reactions shown; Lumber DOL=1.60 plate grip DOL=1.60
- Truss designed for wind loads in the plane of the truss only. For studs exposed to wind (normal to the face), see Standard Industry Gable End Details as applicable, or consult qualified building designer as per ANSI/TPI 1.
- TCLL: ASCE 7-16; Pr=20.0 psf (roof LL: Lum DOL=1.15 Plate DOL=1.15); Pf=20.0 psf (Lum DOL=1.15 Plate DOL=1.15); Is=1.0; Rough Cat B; Fully Exp.; Ce=0.9; Cs=1.00; Ct=1.10
- Unbalanced snow loads have been considered for this design.
- This truss has been designed for greater of min roof live load of 12.0 psf or 1.00 times flat roof load of 20.0 psf on overhangs non-concurrent with other live loads.
- All plates are 2x4 MT20 unless otherwise indicated.
- Gable requires continuous bottom chord bearing.
- Gable studs spaced at 2-0-0 oc.
- This truss has been designed for a 10.0 psf bottom chord live load nonconcurrent with any other live loads.
- \* This truss has been designed for a live load of 20.0psf on the bottom chord in all areas where a rectangle 3-06-00 tall by 2-00-00 wide will fit between the bottom chord and any other members.
- Provide mechanical connection (by others) of truss to bearing plate capable of withstanding 49 lb uplift at joint 2, 55 lb uplift at joint 8, 26 lb uplift at joint 13, 62 lb uplift at joint 14, 26 lb uplift at joint 11, 61 lb uplift at joint 10, 49 lb uplift at joint 2 and 55 lb uplift at joint 8.

13) This truss is designed in accordance with the 2018 International Residential Code sections R502.11.1 and R802.10.2 and referenced standard ANSI/TPI 1.  
**LOAD CASE(S)** Standard

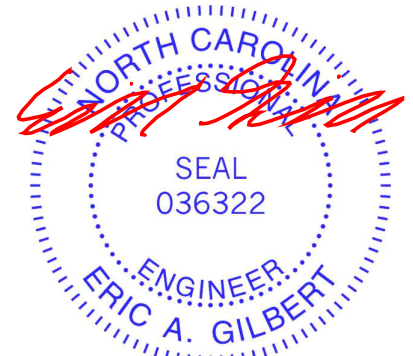

May 24, 2024

**WARNING - Verify design parameters and READ NOTES ON THIS AND INCLUDED MITEK REFERENCE PAGE MII-7473 rev. 1/2/2023 BEFORE USE.**

Design valid for use only with MiTek® connectors. This design is based only upon parameters shown, and is for an individual building component, not a truss system. Before use, the building designer must verify the applicability of design parameters and properly incorporate this design into the overall building design. Bracing indicated is to prevent buckling of individual truss web and/or chord members only. Additional temporary and permanent bracing is always required for stability and to prevent collapse with possible personal injury and property damage. For general guidance regarding the fabrication, storage, delivery, erection and bracing of trusses and truss systems, see **ANSI/TPI Quality Criteria and DSB-22** available from Truss Plate Institute (www.tpinst.org) and **BCSI Building Component Safety Information** available from the Structural Building Component Association (www.sbcacomponents.com)

ENGINEERING BY  
**TRENCO**  
A MiTek Affiliate

818 Soundside Road  
Edenton, NC 27932

Job 24050043-01	Truss B02	Truss Type Common	Qty 7	Ply 1	72 Crown-Eric Boyer-Roof-Eric Boyer Job Reference (optional)	165814896
--------------------	--------------	----------------------	----------	----------	---	-----------

Carter Components (Sanford, NC), Sanford, NC - 27332,

Run: 8.73 S Apr 25 2024 Print: 8.730 S Apr 25 2024 MiTek Industries, Inc. Fri May 24 08:49:37  
ID:u4y?3H181Sm9ywP?\_9UozPzls4m-RfC?PsB70Hq3NSgPqnL8w3uITXbGKWrCDoi7J4zJC?F

Page: 1

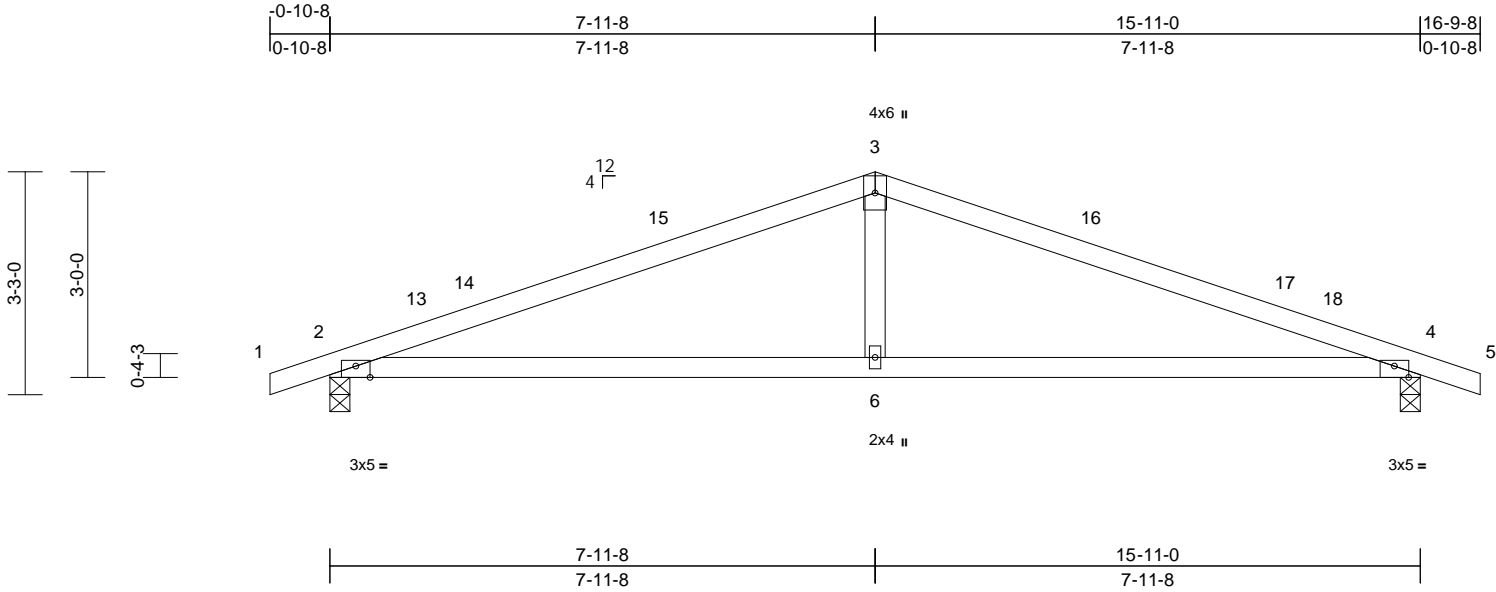

Loading (psf)		Spacing		CSI		DEFL				PLATES		GRIP	
TCLL (roof)	20.0	Plate Grip DOL	1.15	TC	0.61	Vert(LL)	-0.18	6-12	>999	240	MT20	244/190	
Snow (Pf)	20.0	Lumber DOL	1.15	BC	0.74	Vert(CT)	-0.28	6-12	>687	180			
TCDL	10.0	Rep Stress Incr	YES	WB	0.14	Horz(CT)	0.02	4	n/a	n/a			
BCLL	0.0*	Code	IRC2018/TPI2014	Matrix-MSH									
BCDL	10.0										Weight: 55 lb	FT = 20%	

**LUMBER**  
TOP CHORD 2x4 SP 2400F 2.0E  
BOT CHORD 2x4 SP No.1  
WEBS 2x4 SP No.3

**BRACING**  
TOP CHORD Structural wood sheathing directly applied or 5-8-7 oc purlins.  
BOT CHORD Rigid ceiling directly applied or 10-0-0 oc bracing.

**REACTIONS** (size) 2=0-3-8, 4=0-3-8  
Max Horiz 2=-47 (LC 15)  
Max Uplift 2=-108 (LC 10), 4=-108 (LC 11)  
Max Grav 2=768 (LC 21), 4=768 (LC 22)

**FORCES** (lb) - Maximum Compression/Maximum Tension  
TOP CHORD 1-2=0/17, 2-3=-1239/364, 3-4=-1239/364, 4-5=0/17  
BOT CHORD 2-6=-240/1098, 4-6=-240/1098  
WEBS 3-6=0/364

- Unbalanced snow loads have been considered for this design.
- This truss has been designed for greater of min roof live load of 12.0 psf or 1.00 times flat roof load of 20.0 psf on overhangs non-concurrent with other live loads.
- This truss has been designed for a 10.0 psf bottom chord live load nonconcurrent with any other live loads.
- \* This truss has been designed for a live load of 20.0psf on the bottom chord in all areas where a rectangle 3-06-00 tall by 2-00-00 wide will fit between the bottom chord and any other members.
- One H2.5A Simpson Strong-Tie connectors recommended to connect truss to bearing walls due to UPLIFT at jt(s) 2 and 4. This connection is for uplift only and does not consider lateral forces.
- This truss is designed in accordance with the 2018 International Residential Code sections R502.11.1 and R802.10.2 and referenced standard ANSI/TPI 1.

**LOAD CASE(S)** Standard

- NOTES**
- Unbalanced roof live loads have been considered for this design.
  - Wind: ASCE 7-16; Vult=130mph (3-second gust) Vasd=103mph; TCDL=6.0psf; BCDL=6.0psf; h=25ft; Cat. II; Exp B; Enclosed; MWFRS (envelope) exterior zone and C-C Exterior(2E) 0-10-8 to 2-1-8, Interior (1) 2-1-8 to 4-11-8, Exterior(2R) 4-11-8 to 10-11-8, Interior (1) 10-11-8 to 13-9-8, Exterior(2E) 13-9-8 to 16-9-8 zone; cantilever left and right exposed; end vertical left and right exposed; C-C for members and forces & MWFRS for reactions shown; Lumber DOL=1.60 plate grip DOL=1.60
  - TCLL: ASCE 7-16; Pr=20.0 psf (roof LL: Lum DOL=1.15 Plate DOL=1.15); Pf=20.0 psf (Lum DOL=1.15 Plate DOL=1.15); Is=1.0; Rough Cat B; Fully Exp.; Ce=0.9; Cs=1.00; Ct=1.10

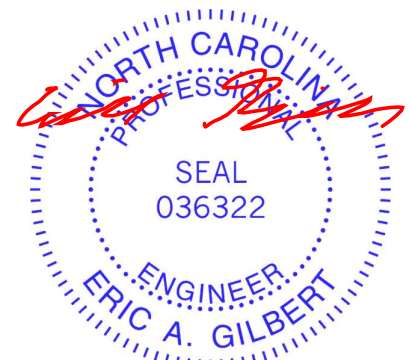

May 24, 2024

# Symbols

## PLATE LOCATION AND ORIENTATION

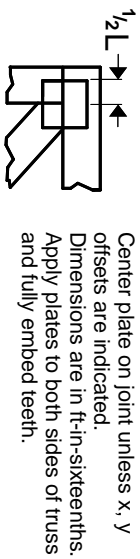

Center plate on joint unless x, y offsets are indicated. Dimensions are in ft-in-sixteenths. Apply plates to both sides of truss and fully embed teeth.

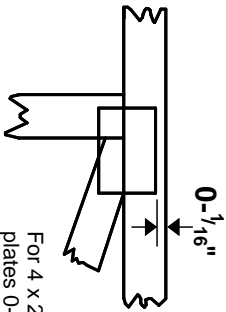

For 4 x 2 orientation, locate plates 0- 1/16\" from outside edge of truss.

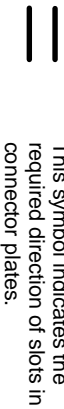

This symbol indicates the required direction of slots in connector plates.

\* Plate location details available in MITek software or upon request.

## PLATE SIZE

4 X 4

The first dimension is the plate width measured perpendicular to slots. Second dimension is the length parallel to slots.

## LATERAL BRACING LOCATION



Indicated by symbol shown and/or by text in the bracing section of the output. Use T or I bracing if indicated.

## BEARING

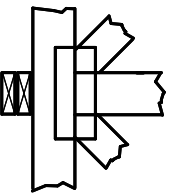

Indicates location where bearings (supports) occur. Icons vary but reaction section indicates joint number/letter where bearings occur. Min size shown is for crushing only.

## Industry Standards:

ANSI/TP1: National Design Specification for Metal Plate Connected Wood Truss Construction.  
DSB-22: Design Standard for Bracing.  
BCSI: Building Component Safety Information, Guide to Good Practice for Handling, Installing, Restraining & Bracing of Metal Plate Connected Wood Trusses.

# Numbering System

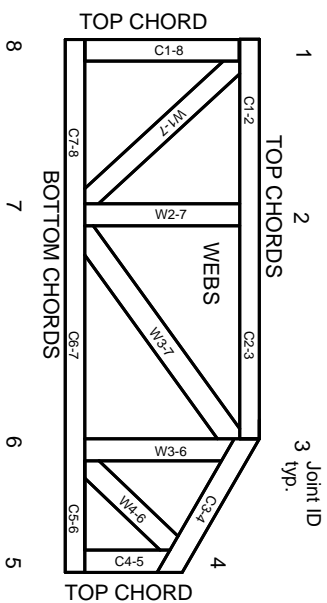

JOINTS ARE GENERALLY NUMBERED/LETTERED CLOCKWISE AROUND THE TRUSS STARTING AT THE JOINT FARTHEST TO THE LEFT.

CHORDS AND WEBS ARE IDENTIFIED BY END JOINT NUMBERS/LETTERS.

# Product Code Approvals

ICC-ES Reports:

ESR-1988, ESR-2362, ESR-2685, ESR-3282  
ESR-4722, ESL-1388

# Design General Notes

Trusses are designed for wind loads in the plane of the truss unless otherwise shown.

Lumber design values are in accordance with ANSI/TP1 section 6.3. These truss designs rely on Lumber values established by others.

© 2023 MITek® All Rights Reserved

# General Safety Notes

## Failure to Follow Could Cause Property Damage or Personal Injury

1. Additional stability/bracing for truss system, e.g. diagonal or X-bracing, is always required. See BCSI.
2. Truss bracing must be designed by an engineer. For wide truss spacing, individual lateral braces themselves may require bracing, or alternative Tor I bracing should be considered.
3. Never exceed the design loading shown and never stack materials on inadequately braced trusses.
4. Provide copies of this truss design to the building designer, erection supervisor, property owner and all other interested parties.
5. Cut members to bear tightly against each other.
6. Place plates on each face of truss at each joint and embed fully. Knots and wane at joint locations are regulated by ANSI/TP1 1.
7. Design assumes trusses will be suitably protected from the environment in accord with ANSI/TP1 1.
8. Unless otherwise noted, moisture content of lumber shall not exceed 19% at time of fabrication.
9. Unless expressly noted, this design is not applicable for use with fire retardant, preservative treated, or green lumber.
10. Camber is a non-structural consideration and is the responsibility of truss fabricator. General practice is to camber for dead load deflection.
11. Plate type, size, orientation and location dimensions indicated are minimum plating requirements.
12. Lumber used shall be of the species and size, and in all respects, equal to or better than that specified.
13. Top chords must be sheathed or purlins provided at spacing indicated on design.
14. Bottom chords require lateral bracing at 10 ft. spacing, or less, if no ceiling is installed, unless otherwise noted.
15. Connections not shown are the responsibility of others.
16. Do not cut or alter truss member or plate without prior approval of an engineer.
17. Install and load vertically unless indicated otherwise.
18. Use of green or treated lumber may pose unacceptable environmental, health or performance risks. Consult with project engineer before use.
19. Review all portions of this design (front, back, words and pictures) before use. Reviewing pictures alone is not sufficient.
20. Design assumes manufacture in accordance with ANSI/TP1 1 Quality Criteria.
21. The design does not take into account any dynamic or other loads other than those expressly stated.

**MITek**

ENGINEERING BY  
**TRENGO**  
A MITek Affiliate

MITek Engineering Reference Sheet: MIL-7473 rev. 1/2/2023