

30x30x12' H BUILDING  
WITH 14x30 SIDE SHELTER  
RAY BRYANT: BUILDER

---

6x6 POST: 6' O.C. ON BUILDING  
6x6 POST: 10' O.C. ON SHELTER  
ALL HOLES 12" x 36" DEEP  
6" CONMIX FOOTING + BACK FILL  
TRUSS 2' O.C.  
2x8 SHELTER RAFTERS 2' O.C.  
2x4 PURLINS TOP + SIDES  
2- 2x10 PLATES ON BUILDING  
2- 2x12 PLATES ON SHELTER  
THROUGH BOLTS ON PLATES  
2.5 HUR. TIES ON TRUSS + RAFTERS  
29 GA. METAL TOP + SIDES

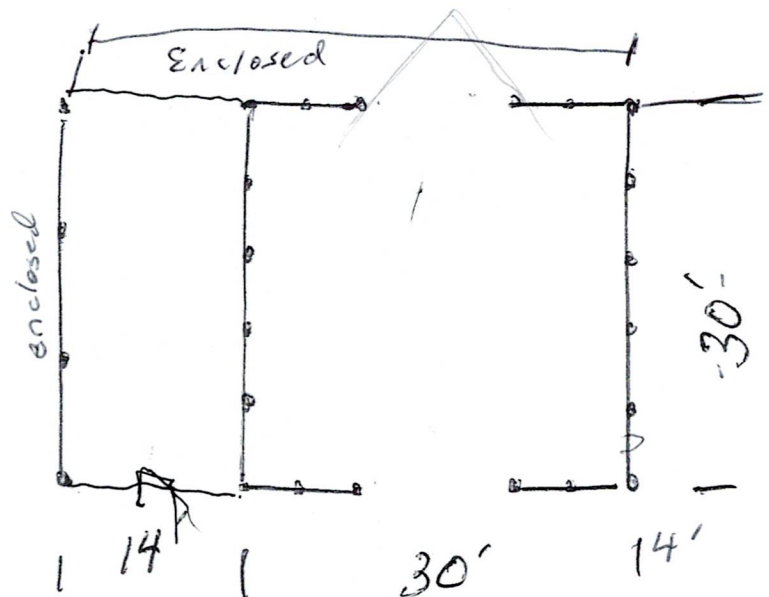



RE: T22-11059 - BRYANT

**Tranco**  
818 Soundside Rd  
Edenton, NC 27932

**Site Information:**

Project Customer:      Project Name:  
Lot/Block:                      Subdivision:  
Model:  
Address:  
City:                                      State:

**General Truss Engineering Criteria & Design Loads (Individual Truss Design Drawings Show Special Loading Conditions):**

Design Code: IRC2018/TPI2014                      Design Program: MITek 20/20 8.3  
Wind Code: ASCE 7-16 [All Heights]              Design Method: MWFRS (Directional) ASCE 7-16 [All Heights]  
Roof Load: 40.0 psf                                      Floor Load: N/A psf  
Mean Roof Height (feet): 12                              Exposure Category: B

No.	Seal#	Truss Name	Date
1	I55500986	T01	12/1/22

The truss drawing(s) referenced above have been prepared by Truss Engineering Co. under my direct supervision based on the parameters provided by Longleaf Truss Company.

Truss Design Engineer's Name: Gilbert, Eric  
My license renewal date for the state of North Carolina is December 31, 2022.

**IMPORTANT NOTE:** The seal on these truss component designs is a certification that the engineer named is licensed in the jurisdiction(s) identified and that the designs comply with ANSI/TPI 1. These designs are based upon parameters shown (e.g., loads, supports, dimensions, shapes and design codes), which were given to MITek or TRENCO. Any project specific information included is for MITek's or TRENCO's customers file reference purpose only, and was not taken into account in the preparation of these designs. MITek or TRENCO has not independently verified the applicability of the design parameters or the designs for any particular building. Before use, the building designer should verify applicability of design parameters and properly incorporate these designs into the overall building design per ANSI/TPI 1, Chapter 2.

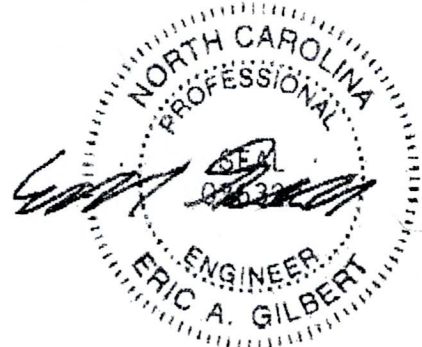

December 1, 2022

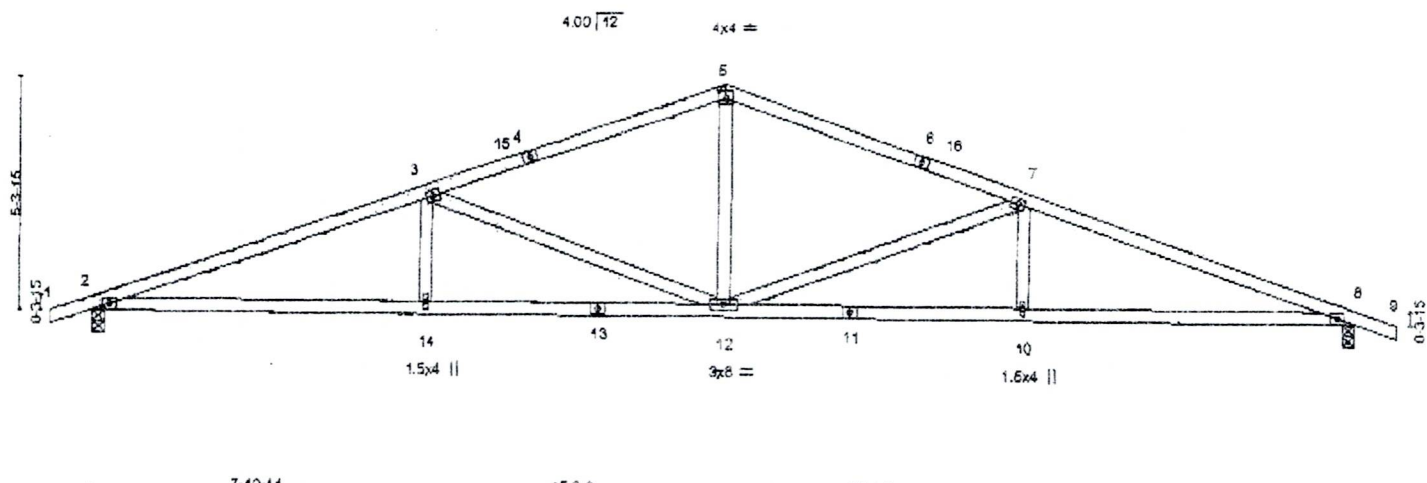
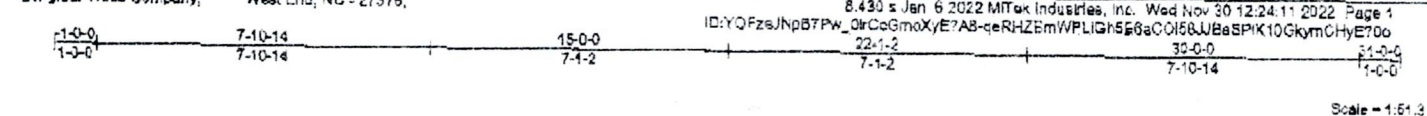

LOADING (psf)		SPACING-		C6I		DEFL.		PLATES		GRIP	
TOLL (roof)	20.0	2-0-0		TC	0.56	in (loc)	l/def	l/d	MT20	244/190	
Snow (P/Pg)	11.6/15.0	Lumber DOL	1.15	BC	0.50	Vert(LL)	-0.17	12	>999	240	
TODL	5.0	Rep Stress Incr	YES	WB	0.83	Vert(CT)	-0.26	12-14	>999	190	
BCLL	0.0	Code IRC2018/TPI2014		Matrix-S		Horz(CT)	0.08	8	n/a	n/a	
BCDL	5.0										Weight: 131 lb FT = 20%

**LUMBER-**  
 TOP CHORD 2x4 SP No.1  
 BOT CHORD 2x4 SP No.1  
 WEBS 2x4 SP No.3

**BRACING-**  
 TOP CHORD Sheathed or 3-5-4 pc purlins.  
 BOT CHORD Rigid ceiling directly applied or 10-0-0 pc bracing.

**REACTIONS.** (size) 2=0-3-8, 8=0-3-8  
 Max Horz 2=58(LC 11)  
 Max Uplift 2=154(LC 12), 8=154(LC 12)  
 Max Grav 2=949(LC 2), 8=949(LC 2)

**FORCES.** (lb) - Max. Comp./Max. Ten. - All forces 250 (lb) or less except when shown.  
 TOP CHORD 2-3=-2196/307, 3-5=-1473/231, 5-7=-1473/231, 7-8=-2196/307  
 BOT CHORD 2-14=-248/2024, 12-14=-248/2024, 10-12=-248/2024, 8-10=-248/2024  
 WEBS 3-12=-64/584, 3-12=-757/134, 7-12=-757/134

- NOTES.**
- Unbalanced roof live loads have been considered for this design.
  - Wind: ASCE 7-16; Vult=120mph (3-second gust) Vasd=95mph; TODL=3.0psf, BCCL=3.0psf, h=12ft, B=45ft, L=30ft; eave=4ft; Cat. II; Exp B; Enclosed, MWFRS (directional); cantilever left and right exposed; end vertical left and right exposed; Lumber DOL=1.60 plate grip DOL=1.50
  - TOLL ASCE 7-16; Pr=20.0 psf (roof LL); Lum DOL=1.15 Plate DOL=1.15; Pg=15.0 psf; Pf=11.6 psf (Lum DOL=1.15 Plate DOL=1.15); le=1.0; Rough Cat B; Partially Exp.; Ce=1.0 Cs=1.00; Ct=1.0
  - Unbalanced snow loads have been considered for this design.
  - This truss has been designed for greater of min roof live load of 12.0 psf or 1.00 times flat roof load of 11.6 psf on overhangs non-concurrent with other live loads.
  - Dead loads shown include weight of truss. Top chord dead load of 5.0 psf (or less) is not adequate for a shingle roof. Architect to verify adequacy of top chord dead load.
  - All plates are 3x4 MT20 unless otherwise indicated.
  - This truss has been designed for a 10.0 psf bottom chord live load nonconcurrent with any other live loads.
  - \* This truss has been designed for a live load of 20.0psf on the bottom chord in all areas where a rectangle 3-6-0 tall by 2-0-0 wide will fit between the bottom chord and any other members.
  - Provide mechanical connection (by others) of truss to bearing plate capable of withstanding 100 lb uplift at joint(s) except (t=lb) 2=154, 8=154.
  - This truss is designed in accordance with the 2018 International Residential Code sections R502.11.1 and R802.10.2 and referenced standard ANSI/TPI 1.

