

- DESIGN CRITERIA**
- 2018 NORTH CAROLINA STATE BUILDING CODES
 - ASCE 7-10
- DESIGN LOADS**
- LIVE LOAD (ROOF) = 20 PSF
 - LIVE LOAD (CEILING-NON STORAGE) = 10 PSF
 - LIVE LOAD (FLOOR) = 40 PSF
 - LIVE LOAD (DECK) = 40 PSF
 - GROUND SNOW LOAD = 15 PSF
 - ULTIMATE WIND VELOCITY = 115 MPH
 - EXPOSURE CATEGORY = B
 - ASSUMED GROUND BEARING CAPACITY 12" BELOW GRADE: 2,000 PSF (CONTRACTOR RESPONSIBLE FOR VERIFICATION)

- GENERAL NOTES**
- CONTRACTOR SHALL BE RESPONSIBLE FOR LOCATING AND PROTECTING EXISTING UNDERGROUND UTILITIES IN THE AREA OF CONSTRUCTION.
 - THE CONTRACTOR SHALL COORDINATE THEIR WORK ACTIVITIES WITH THE OWNER OR OWNER REPRESENTATIVE.
 - CONTRACTOR SHALL MAKE A CAREFUL INSPECTION OF THE SITE TO FAMILIARIZE HIMSELF WITH THE ACTUAL CONDITIONS OF THE SITE PRIOR TO CONSTRUCTION.
 - CONTRACTOR SHALL CHECK AND VERIFY GIVEN DIMENSIONS, TAKE ADDITIONAL DIMENSIONS AS REQUIRED AND REPORT ANY INACCURACIES TO THE ENGINEER BEFORE BEGINNING CONSTRUCTION.
 - ALL WORK SHALL CONFORM TO THE THE CURRENT EDITIONS OF THE NORTH CAROLINA STATE BUILDING CODE, THE AISC CODE, THE ACI BUILDING CODE (ACI 318), THE AMERICAN WELDING SOCIETY CODE, ALL APPLICABLE ASTM STANDARDS, AND LOCAL GUIDELINES. IN CASES OF CONFLICT, THE MOST STRINGENT REQUIREMENT SHALL GOVERN.
 - CONTRACTOR SHALL COORDINATE AND VERIFY THE SIZE, LOCATION, TYPE, AND DIRECTION OF ALL PADS, DEPRESSIONS, BOLTS, SLEEVES, ANCHORS, INSERTS, OPENINGS, ETC. TO BE SET OR CAST IN CONCRETE PRIOR TO PLACEMENT.
 - CONTRACTOR SHALL COORDINATE ALL DIMENSIONS WITH ARCHITECTURAL DRAWINGS PRIOR TO FOUNDATION LAYOUT AND FABRICATION OF ANY STRUCTURAL MEMBERS. DIMENSIONS SHOWN ARE BASED ON PRELIMINARY DRAWINGS PROVIDED BY THE ARCHITECT/CONTRACTOR AND/OR SITE INSPECTION. THESE DIMENSIONS SHOULD BE VERIFIED BY THE CONTRACTOR PRIOR TO CONSTRUCTION.
 - CONTRACTOR SHALL DESIGN AND INSTALL ALL TEMPORARY SHORING REQUIRED TO STABILIZE NEW AND EXISTING STRUCTURES AND FOUNDATIONS UNTIL CONSTRUCTION IS COMPLETE.
 - OMISSIONS OR CONFLICTS BETWEEN VARIOUS ELEMENTS OF THE DRAWINGS, SPECIFICATIONS, NOTES, AND DETAILS SHALL BE BROUGHT TO THE ATTENTION OF THE ENGINEER, AND RESOLVED BEFORE PROCEEDING WITH WORK.
 - THE DRAWINGS AND SPECIFICATIONS REPRESENT THE FINISHED STRUCTURE. THE STRUCTURE SHOWN IS STRUCTURALLY SOUND IN ITS COMPLETED FORM ONLY. THEY DO NOT INDICATE THE METHOD OF CONSTRUCTION. THE CONTRACTOR SHALL PROVIDE ALL MEASURES NECESSARY TO PROTECT THE STRUCTURE DURING CONSTRUCTION.
 - APPLY TERMITTE TREATMENT TO GROUND SURFACES WITHIN THE DEFINED SCOPE OF WORK AS REQUIRED BY CODE AND LOCAL BUILDING INSPECTOR.
 - ONLY SEALED DRAWINGS WITH MOST RECENT REVISIONS ARE APPLICABLE FOR CONSTRUCTION.
 - STRUCTURAL PLANS DO NOT INCORPORATE ADA, PLUMBING, MECHANICAL, ELECTRICAL, OR SITE FEATURES. ENGINEER'S SEAL APPLIES TO STRUCTURAL COMPONENTS ONLY.
 - SECTIONS AND DETAILS SHOWN AT LOCATIONS INDICATED ON PLAN ARE TYPICAL FOR OTHER SIMILAR CONDITIONS OF BUILDING, EVEN IF NO SECTION CUT IS INDICATED AT A SIMILAR CONDITION. CONTRACTOR IS RESPONSIBLE FOR COORDINATION OF ALL DETAILS WITH OTHER TRADES, DISCIPLINES, AND ALL SECTIONS AND DETAILS WITHIN STRUCTURAL DOCUMENTS. CONTRACTOR SHALL REVIEW THESE STRUCTURAL DRAWINGS WITH DRAWINGS OF OTHER DISCIPLINES. SHOULD CONFLICTS OR DEVIATIONS BE NOTED, THEY SHOULD BE IMMEDIATELY BROUGHT TO THE ATTENTION OF SUBJECT DESIGNERS FOR REVIEW.
 - IN THE CASE WHERE NEW STRUCTURE IS INTEGRATED INTO EXISTING STRUCTURE, THE EXISTING STRUCTURE IS TO REMAIN UNMODIFIED UNLESS EXPLICITLY DESCRIBED IN THE DESIGN PLANS. ANY DAMAGE TO EXISTING STRUCTURE IDENTIFIED DURING CONSTRUCTION SHALL BE BROUGHT TO THE ATTENTION OF THE ENGINEER OR REVIEW PRIOR TO RESUMING WORK.

- SOIL FOUNDATIONS**
- ALL BOTTOM OF FOOTINGS SHALL BE CAST A MINIMUM OF 12" BELOW ORIGINAL GROUND LINE AND IN NO CASE ABOVE THE FROST LINE BASED ON 2018 NCBC AND LOCAL STANDARDS. NO FOOTINGS SHALL BE CAST ON LOOSE FILL MATERIAL.
 - ALL FILL SHALL BE PLACED IN 8" MAXIMUM LOOSE LIFTS AND SHALL BE COMPACTED TO A MINIMUM OF 95 PERCENT MAXIMUM DRY DENSITY AS DETERMINED IN ACCORDANCE WITH ASTM D-698 (STANDARD PROCTOR METHOD). THIS REQUIREMENT SHALL BE INCREASED TO 98 PERCENT OF ASTM D-698 IN THE FINAL FOOT BENEATH FLOOR SLABS AND PAVEMENTS.
 - USE OF A SMOOTH EDGE BUCKET IS RECOMMENDED TO EXCAVATE FOR FOOTINGS. TOOTHED BUCKETS MAY ALLOW BEARING SOILS TO PERFORM INEFFECTIVELY AND ALLOW WATER TO SATURATE THE FOUNDATION SUB-GRADE.
 - ONCE FOOTINGS ARE ABLE TO HANDLE LATERAL LOADING, BACKFILL WITH ENGINEERED STONE OR NO. 57 STONE IN 8" UNIFORM LIFTS. EXTERIOR OF THE FOOTING MAY BE BACKFILLED WITH 8" UNIFORM LIFTS OF SUITABLE SOILS COMPACTED TO 95% OF THE DRY DENSITY BEYOND THE PLACEMENT OF THE FOOTING DRAIN.
 - WITHIN CRAWL SPACES A MINIMUM 6-MIL VAPOR BARRIER SHALL BE INSTALLED ON BARE SOILS.

- REINFORCING**
- ALL DETAILING, FABRICATION AND PLACING OF REINFORCING STEEL SHALL BE IN ACCORDANCE WITH THE LATEST "MANUAL OF STANDARD PRACTICE FOR DETAILING REINFORCED CONCRETE STRUCTURES," ACI 315.
 - CLEAR CONCRETE COVER OVER BARS SHALL BE 3" FOR FOOTINGS AND OTHER CONCRETE CAST AGAINST GROUND. CONCRETE COVER IN OTHER LOCATIONS TO BE A MINIMUM 1.5" (TYP. U.N.O.)
 - PROVIDE CORNER BARS AT ALL FOOTING STEPS AND CORNERS. THE REINFORCING BARS SHALL BE A MINIMUM OF 2'-6" LONG AND SHALL HAVE THE SAME SIZE AND SPACING AS THE HORIZONTAL REINFORCING.
 - LAP ALL SPLICES IN CONCRETE AS SPECIFICALLY CALLED FOR, BUT AT LEAST 48 BAR DIAMETERS FOR COMPRESSION, UNLESS NOTED OTHERWISE.
 - PROVIDE VERTICAL REINFORCEMENT IN FOUNDATION WALLS FOR UNBALANCED BACKFILL IN ACCORDANCE WITH APPLICABLE DESIGN DETAILS. WHERE NOT DETAILED IN PLAN, REINFORCEMENT SHALL BE INSTALLED PER TABLE R404.1.1(1) & (2) IN THE 2018 NCBC-RC.
 - REINFORCING BARS SHALL BE DEFORMED AND PLAIN CARBON-STEEL CONFORMING TO ASTM A615, GRADE 60.
 - WELDED WIRE FABRIC SHALL CONFORM TO ASTM A1064 AND BE SUPPLIED IN SHEETS, NOT ROLLS. U.N.O. MINIMUM 6X6 - W1.4 X W1.4 WELDED WIRE FABRIC. MINIMUM 1.5" FROM BOTTOM OF CONCRETE SLAB ON GRADES.

- CONCRETE NOTES**
- CONCRETE CONSTRUCTION SHALL COMPLY WITH ACI 301 "SPECIFICATIONS FOR STRUCTURAL CONCRETE FOR BUILDINGS" (LATEST EDITION), ACI 318 "BUILDING CODE REQUIREMENTS FOR REINFORCED CONCRETE" (LATEST EDITION), AND ACI 302 "GUIDE FOR CONCRETE FLOOR AND SLAB CONSTRUCTION" (LATEST EDITION).
 - MIX DESIGN SHALL BE IN ACCORDANCE WITH ACI 318 (CURRENT EDITION).
 - MINIMUM CEMENT CONTENT = 500 LBS PER CUBIC YARD.
 - CONCRETE SHALL BE NORMAL WEIGHT CONCRETE AND SHALL DEVELOP A MINIMUM COMPRESSIVE STRENGTH OF 3,000 PSI AT 28 DAYS (4,000 PSI FOR SLABS-ON-GRADE).
 - MAXIMUM SLUMP = 4" PRIOR TO THE ADDITION OF ADMIXTURES.
 - THE MAX. AGGREGATE SIZE SHALL BE 3/4" UNLESS MIX DESIGN IS APPROVED BY ENGINEER PRIOR TO PLACEMENT.
 - CONCRETE AGGREGATES SHALL COMPLY WITH ASTM C33 AND SHALL BE FREE OF CLAY, FOAM, LUMPS, OR OTHER DELETERIOUS SUBSTANCES.
 - CONCRETE SHALL BE CONSOLIDATED USING CONCRETE VIBRATOR IN ACCORDANCE WITH ACI 309R-05.
 - DO NOT USE AIR ENTRAINMENT ON INTERIOR SLABS (3% MAXIMUM AIR ENTRAINMENT). AIR ENTRAINMENT SHALL COMPLY WITH ASTM C260.
 - THE CONTROL JOINT SPACING SHALL BE A MAXIMUM OF 12' OR AS SHOWN ON PLANS FOR A 4" THICK SLAB. PLACE CONTROL JOINTS TO AVOID RE-ENTRANT CORNERS. MAKE SAWCUTS TO FORM WEAKEN PLANE CONTROL JOINTS AS SOON AS POSSIBLE.

- GENERAL FRAMING DESIGN NOTES**
- FRAMING STANDARD: COMPLY WITH AF&PA'S "DETAILS FOR CONVENTIONAL WOOD FRAME CONSTRUCTION", UNLESS OTHERWISE INDICATED.
 - ALL EXTERIOR WALLS SHALL BE FRAMED WITH 2X4 STUDS SPACED AT 16" O.C., U.N.O. (MAXIMUM HEIGHT = 10'-0")
 - ALL INTERIOR WALLS SHALL BE FRAMED WITH 2X4 STUDS SPACED UP TO 16" O.C., U.N.O. (MAXIMUM HEIGHT = 11'-0")
 - USE 1/2" DIAMETER ANCHOR BOLTS, 7" MINIMUM EMBEDMENT IN CMU, AT A MAXIMUM OF 6" ON CENTER AND A MAXIMUM OF 12" FROM CORNERS AND OPENINGS EXCEEDING 4" IN WIDTH.
 - NAIL 2X BOTTOM PLATE TO RIM JOIST BELOW WITH 16D NAILS AT 4" O.C. SPACING.
 - INSTALL METAL HANGERS, TIES, CLIPS, ETC. PER MANUFACTURER'S WRITTEN INSTRUCTIONS.
 - DO NOT SPLICE BUILT-UP BEAM MEMBERS BETWEEN SUPPORTS UNLESS OTHERWISE INDICATED.
 - WHERE BUILT-UP BEAMS OR GIRDERS OF 2-INCH NOMINAL DIMENSIONAL LUMBER ON EDGE ARE REQUIRED, FASTEN TOGETHER WITH 3 ROWS OF 16D NAILS SPACED NOT LESS THAN 24" O.C. LOCATED ONE ROW 1.5" FROM TOP EDGE AND ONE ROW 1.5" FROM BOTTOM EDGE.

- FOR BUILT-UP (GANG) COLUMNS, CONNECT EACH PLY W/ (2) ROWS OF 10D NAILS AT 12" O.C.
- INSTALL EQUIVALENT, SOLID BLOCKING BELOW ALL STUD GROUPS TO ENSURE CONTINUOUS LOAD PATH TO THE FOUNDATION.
- INSTALL MINIMUM FULL LENGTH (BEARING POINT TO BEARING POINT) 2-PLY JOISTS BELOW PARALLEL PARTITION WALL SECTIONS DURING THIS SETTING PERIOD.
- LEVEL TO LEVEL STRAP TIES: LAP EXTERIOR SHEATHING PANELS AT LEAST 24" ABOVE BOTTOM PLATE OR BELOW TOP PLATE.
- SEE FRAMING PLANS FOR ALL BEARING HEADER SIZES.
- ALL ROOF FRAMING MUST BE TIED TO THE FRAMING BELOW WITH SIMPSON H2.5/4 TIES, TRUSS SCREWS, OR EQUIVALENT FASTENING MECHANISM.
- ALL LUMBER EXPOSED TO CONCRETE/MASONRY OR WEATHER MUST BE PRESSURE TREATED.
- ALL FASTENERS/METAL HARDWARE EXPOSED TO WEATHER OR PRESSURE TREATED LUMBER MUST BE GALVANIZED/STAINLESS STEEL.
- ALL FASTENING SHALL CONFORM TO TABLE R602.3(1) IN THE 2018 NCBC-RC.
- ALL DECK FRAMING COMPONENTS ARE TO BE INSTALLED PER 2018 NCBC-RC APPENDIX M.
- PROVIDE KING STUDS AT NEW EXTERIOR OPENINGS PER 2018 NCBC-RC TABLE R602.3(5) SUBNOTE "d". ONE HALF OF THE STUDS INTERRUPTED BY A WALL OPENING SHALL BE PLACED IMMEDIATELY OUTSIDE THE JACK STUDS ON EACH SIDE OF THE OPENING AS KING STUDS ... KING STUDS SHALL EXTEND FULL HEIGHT FROM SOLE PLATE TO TOP PLATE OF WALL"

- DIMENSIONAL LUMBER FRAMING**
- MAXIMUM MOISTURE CONTENT: 19%.
 - NO. 2 GRADE OR BETTER (EXCEPT STUD WALLS) AND ANY OF THE FOLLOWING SPECIES:
 - HEM-FIR (NORTH), NLGA.
 - SOUTHERN PINE, SPIB.
 - DOUGLAS FIR-LARCH, WCLIB OR WWPA.
 - MIXED SOUTHERN PINE, SPIB.
 - SPRUCE-PINE-FIR, NLGA.
 - DOUGLAS FIR-SOUTH, WWPA.
 - HEM-FIR, WCLIB OR WWPA.
 - DOUGLAS FIR-LARCH (NORTH), NLGA.
 - EXTERIOR, LOAD BEARING AND INTERIOR PARTITION WALLS: ANY SPECIES (STUD GRADE OR BETTER) WITH A MODULUS OF ELASTICITY OF AT LEAST 1,300,000 PSI AND EXTREME FIBER STRESS IN BENDING OF AT LEAST 650 PSI FOR 2" NOMINAL THICKNESS AND 12" NOMINAL WIDTH FOR A SINGLE MEMBER USE.
 - JOISTS, RAFTERS, AND OTHER FRAMING NOT LISTED ABOVE: ANY SPECIES (NO. 2 OR BETTER) WITH A MODULUS OF ELASTICITY OF AT LEAST 1,300,000 PSI AND AN EXTREME FIBER STRESS IN BENDING OF AT LEAST 850 PSI FOR 2" NOMINAL THICKNESS AND 12" NOMINAL WIDTH FOR SINGLE MEMBER USE.

- SHEATHING DESIGN NOTES**
- UNLESS NOTED OTHERWISE: SHEATH ROOF AND WALLS WITH EXPOSURE 1, 7/16"-THICK APA STRUCTURE SHOWN IS STRUCTURALLY SOUND IN ITS COMPLETED FORM ONLY. THEY DO NOT INDICATE THE METHOD OF CONSTRUCTION. THE CONTRACTOR SHALL PROVIDE ALL MEASURES NECESSARY TO PROTECT THE STRUCTURE DURING CONSTRUCTION.
 - WHERE WALL TOP PLATE IS DISCONTINUOUS AT EXTERIOR PERIMETERS, APPLY MSTC40 STRAP TO COMPLETE THE TENSILE LOAD PATH. POSITION TOP PLATE SPLICES OVER WALL STUDS.
 - INSTALL "H" CLIPS AT PANEL EDGES BETWEEN EACH RAFTER/TRUSS FOR ALL ROOF SHEATHING.
 - NAIL ALL SHEATHING AT GABLE AND EAVE ROOF OVERHANGS WITH 8D NAILS AT 6" O.C. EDGES, 6" O.C. FIELD.
 - NAIL ALL SHEATHING AT PERIMETER AND PEAK OF ROOF WITH 8D NAILS AT 6" O.C. EDGES, 6" O.C. FIELD.
 - NAIL ALL SHEATHING WITHIN 4'-0" OF WALL CORNERS WITH 8D NAILS AT 6" O.C. EDGES, 6" O.C. FIELD.
 - SUBFLOORING SHALL BE IN ACCORDANCE WITH TABLE R503.1 WITHIN RESIDENTIAL BUILDING CODE OR ENGINEER APPROVED ALTERNATIVE.
 - MEMBERS AND BLOCKING AT ADJOINING PANEL EDGES SHALL BE MINIMUM 3" NOMINAL OR DOUBLE 2" NOMINAL WITH STAGGERED NAILING AT ALL PANEL EDGES.
 - HORIZONTAL BLOCKING MAY BE 2X LAID FLAT AGAINST SHEATHING.
 - AT EXISTING STRUCTURE WHERE SHEATHING IS IN PLACE, NEW SHEATHING SHALL BE KEYS IN A MINIMUM OF 2" WITHIN EVERY OTHER SHEATHING PLANE.

- STRUCTURAL MASONRY:**
- LOAD BEARING MASONRY WALLS, PILASTERS, PIER, RETAINING WALLS, FOUNDATION WALLS AND ANY OTHER MASONRY SO DESIGNATED ON DRAWINGS IS CONSIDERED HERE TO BE STRUCTURAL MASONRY.
 - REQUIRED COMPRESSIVE STRENGTH OF MASONRY UNITS:
 - CONCRETE UNITS - 1900 PSI ON NET AREA.
 - CONCRETE MASONRY UNITS (CMU) SHALL BE NORMAL WEIGHT (125 PCF) CONFORMING TO ASTM C90. REFER TO ARCHITECTURAL DRAWINGS FOR UNIT SIZE, FACE, COLOR, JOINTING, ETC. NOTE, AAC MASONRY TO CONFORM TO MANUFACTURER SPECIFICATIONS WHERE NOT DETAILED.
 - MORTAR - TYPE S, ASTM C270
 - GRAOUT FOR REINFORCED MASONRY - FINE GRAOUT, ASTM C476. MINIMUM 28 DAY COMPRESSIVE STRENGTH - 2000 PSI
 - MINIMUM 28-DAY COMPRESSIVE STRENGTH (Fm) OF CMU MASONRY WALLS SHALL BE 1500 PSI. MASONRY STRENGTH SHALL BE DETERMINED BY THE UNIT STRENGTH METHOD OR THE PRISM TEST METHOD AS DESCRIBED BY ACI 530.
 - REINFORCING:
 - ASTM A615 - GRADE 60
 - ALL REINFORCING TO BE WELDED - ASTM A706
 - REFER TO THE DRAWINGS FOR REINFORCING LAP TYPICAL DETAIL AND SCHEDULE REQUIREMENTS. WHERE LAP SPLICES ARE NOT SHOWN, LAP PER ACI 530.
 - MAXIMUM HEIGHT TO WHICH MASONRY SHALL BE LAID BEFORE GROUTING IS 5-FEET ABOVE CONSTRUCTION SURFACE OR PREVIOUSLY GROUTED MASONRY. PROVIDE CLEANOUT OPENINGS AT THE BOTTOM OF EACH GROUT LIFT.
 - REINFORCE MASONRY WHERE SHOWN ON STRUCTURAL DRAWINGS. THE REINFORCING IN POSITION AND PLACE GROUT AROUND REINFORCING. DO NOT PUSH REINFORCING DOWN INTO PREVIOUSLY PLACED GROUT FILL. SET BOLTS SIMILARLY.
 - TIE MASONRY WYTHES WITH HORIZONTAL REINFORCING AS SPECIFIED.
 - EMBEDDED ANCHORS INTO MASONRY (OR CONCRETE) ARE TO BE INSTALLED PER PLAN WITH SIMPSON "SET" EPOXY (OR EQUIV.). PROVIDE ADHESIVE SCREENS OR OTHER APPROVED ANCHORAGE FOR HOLLOW MASONRY. MECHANICAL WEDGE ANCHORS ARE NOT PERMITTED WITHIN MASONRY.
 - PROVIDE VERTICAL BARS, SIZE MATCHING WALL REINFORCING, AT ALL CORNERS, ENDS OF WALLS, EACH SIDE OF CONTROL JOINTS, AND EACH SIDE OF WALL OPENINGS.
 - PROVIDE MASONRY CONTROL JOINTS (PER ACI 530) SPACED UP TO 25'-0" O.C.
 - ALL CORNERS AND INTERSECTIONS OF STRUCTURAL MASONRY SHALL BE CONSTRUCTED BY INTERLOCKING COURSES.

- EPOXY ADHESIVE ANCHORS**
- ALL EPOXY SHALL BE SIMPSON BRAND "SET" EPOXY SYSTEM, OR APPROVED EQUAL, UNLESS NOTED OTHERWISE.
 - EPOXY ADHESIVES TO BE INSTALLED IN STRICT ACCORDANCE WITH MANUFACTURER'S SPECIFICATIONS AND INSTRUCTIONS.
 - ALL EPOXY ANCHOR BOLTS TO BE SIZED AS SHOWN IN NOTES/DETAILS AND SHALL CONFORM TO THE FOLLOWING:
 - ANCHOR BOLTS INTO FOUNDATION: ASTM F1554, GRADE 36
 - ALL OTHER APPLICATIONS: ASTM 307, U.N.O.
 - ALL EPOXY ANCHOR BOLTS AND REBAR DOWELS SHOULD BE CLEAN AND OIL FREE.
 - CONCRETE DUST SHALL BE REMOVED FROM ALL DRILLED HOLES BY USE OF A NYLON BRUSH AND OIL FREE COMPRESSED AIR. CORRECT PROCEDURE INVOLVES BLOWING THE DUST OUT OF THE HOLE, BRUSHING THE HOLE CLEAN, AND THEN BLOWING AGAIN.
 - DRILLED HOLES SHALL BE KEPT DRY AND ANY STANDING WATER MUST BE BLOWN OUT WITH OIL FREE COMPRESSED AIR AND ALLOWED TO DRY PRIOR TO EPOXY INSTALLATION.
 - EPOXY SHALL NOT BE INSTALLED IN CONCRETE WHICH IS LESS THAN 7 DAYS OLD.
 - EPOXY ADHESIVES MUST BE ALLOWED THE FULL CURE TIME AS SPECIFIED BY THE MANUFACTURER PRIOR TO APPLICATION OF ANY LOAD AND ANCHOR BOLTS OR REBAR DOWELS MUST REMAIN UNDISTURBED DURING THIS SETTING PERIOD.
 - EPOXY ADHESIVE ANCHORS ARE NOT TO BE USED EXCEPT WHERE SPECIFICALLY INDICATED ON PLANS.

TYPICAL ABBREVIATIONS

&	= AND	F.J.	= FLOOR JOISTS
@	= AT	FTG.	= FOOTING
±	= PLUS OR MINUS	GA.	= GAUGE
A/E	= ARCHITECT/ENGINEER	HT.	= HEIGHT
A.F.F.	= ABOVE FINISHED FLOOR	MAX.	= MAXIMUM
ARCH.	= ARCHITECTURAL	MECH.	= MECHANICAL
B.O.	= BY OTHERS	MFR.	= MANUFACTURER
C.C.J.	= CONCRETE CONTROL JOINT	MIN.	= MINIMUM
C.J.	= CEILING JOIST	N.T.S.	= NOT TO SCALE
C.L.	= CENTER LINE	O.C.	= ON CENTER
C.M.U.	= CONCRETE MASONRY UNIT	P.B.	= PERIMETER BAND
CONC.	= CONCRETE	PL	= PLATE
CONT.	= CONTINUOUS	REQ.	= REQUIRED
DEFL.	= DEFLECTION	R.O.	= ROUGH OPENING
Ø, DIA.	= DIAMETER	SIM.	= SIMILAR
DWG.	= DRAWING	STL.	= STEEL
ELEV.	= ELEVATION	SW	= SHEAR WALL
ENGR.	= ENGINEER	STR.	= STRUCTURAL
E.O.S.	= EDGE OF SLAB	TEMP.	= TEMPORARY
EQ.	= EQUAL	TYP.	= TYPICAL
EW	= EACH WAY	U.N.O.	= UNLESS NOTED OTHERWISE
EX	= EXISTING	VERT.	= VERTICAL
FDN.	= FOUNDATION	VIF	= VERIFY IN FIELD
F.LR.	= FLOOR	W/	= WITH

NOTE: MAXIMUM JOINT SPACING SHALL BE 12'-0" FT. IN EACH DIRECTION UNLESS SHOWN OTHERWISE ON PLAN

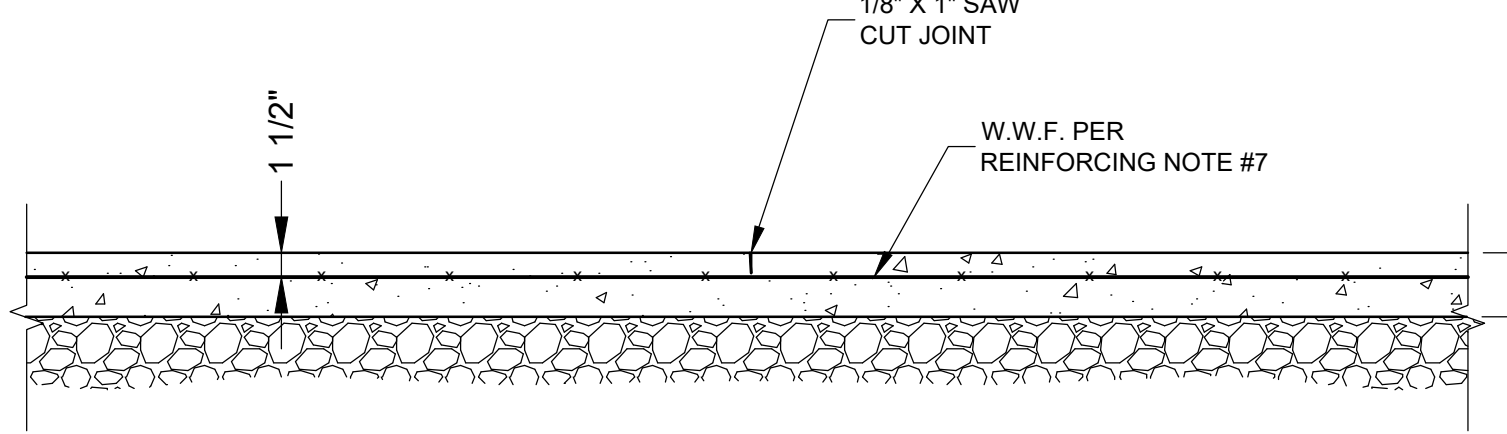

1 TYP. SLAB CONTROL JOINT
SCALE: N.T.S.

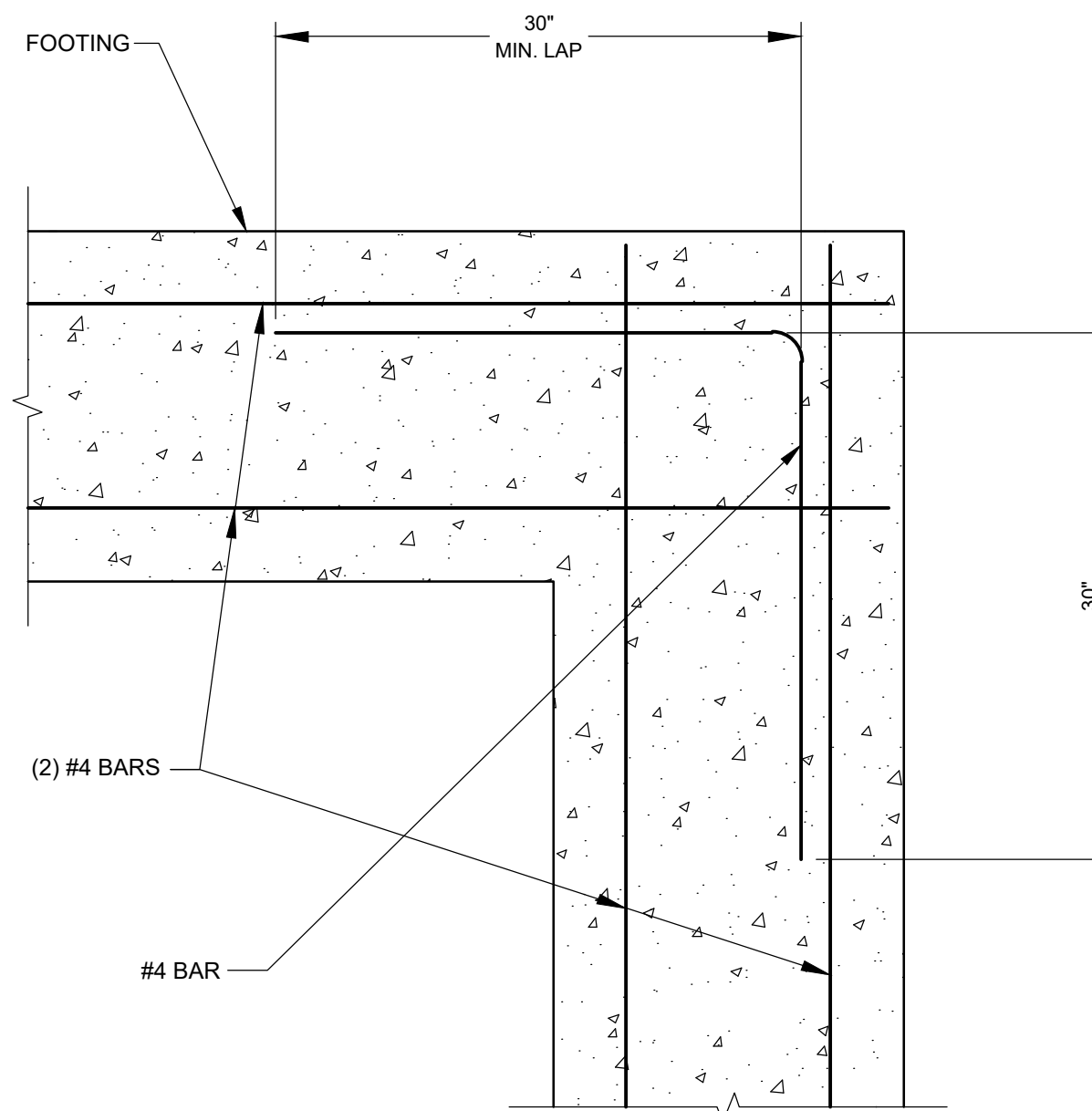

3 TYP. CONTINUITY CORNER
SCALE: N.T.S.

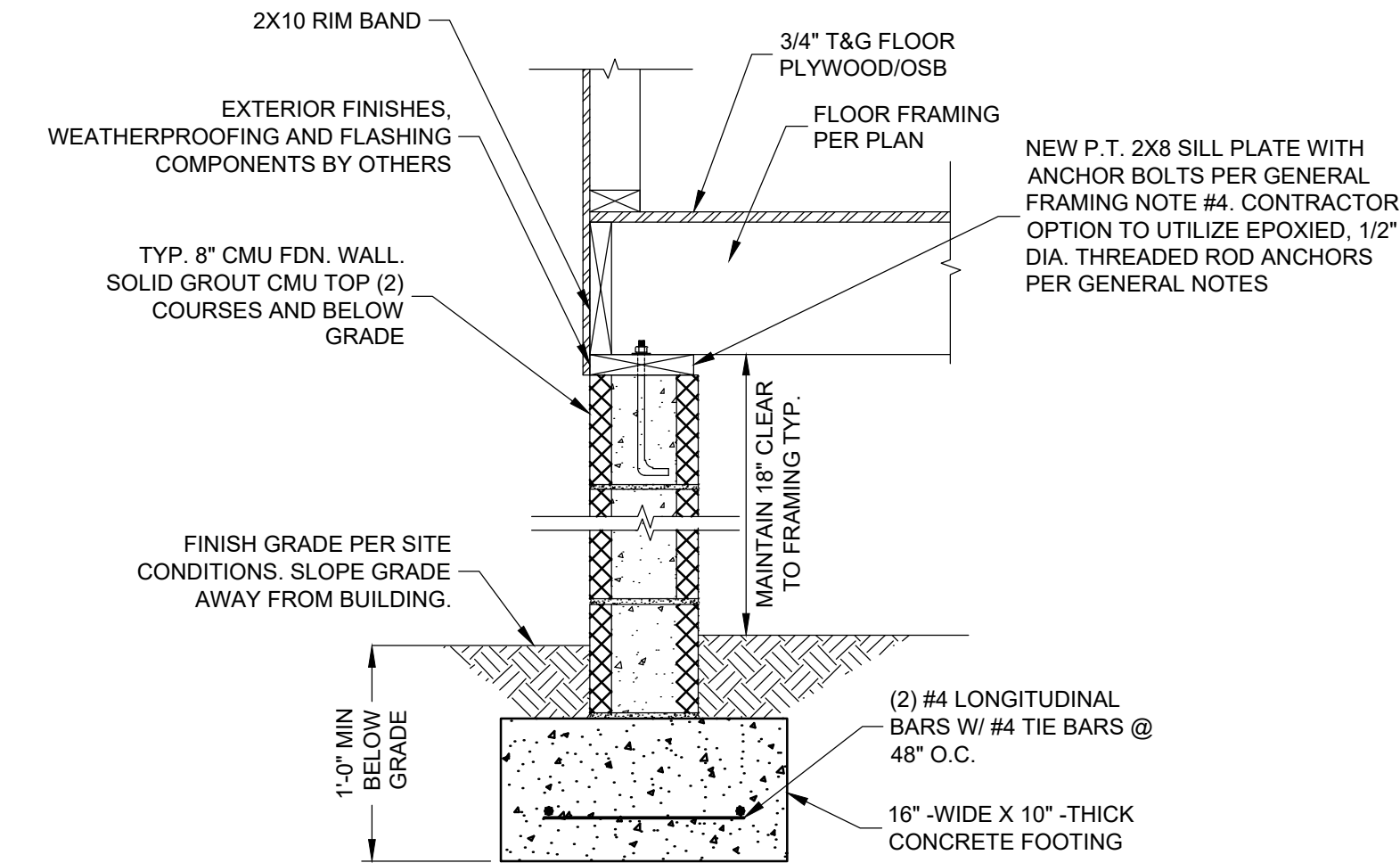

2 TYP. FOUNDATION SECTION
SCALE: N.T.S.

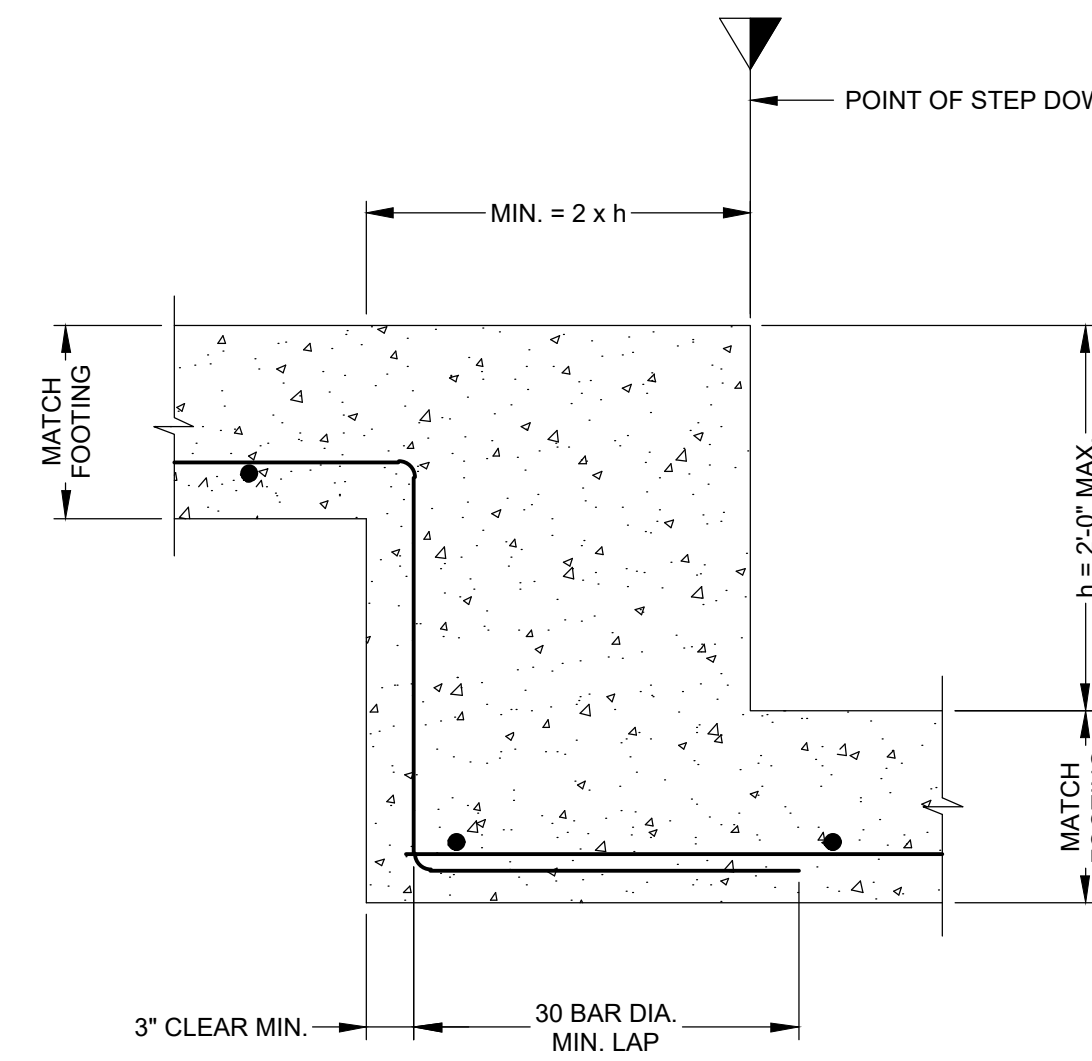

4 TYP. FTG. STEP (AS REQ.)
SCALE: N.T.S.

SHEET INDEX

S1.0	COVER SHEET & GENERAL NOTES
S2.0	FOUNDATION PLAN
S3.0	FLOOR FRAMING PLAN
S4.0	CEILING/WALL FRAMING
S5.0	ROOF FRAMING PLAN

GILES & FLYTHE
ENGINEERS
7334 CHAPEL HILL ROAD, SUITE 200
RALEIGH, NC 27607 (919) 465-3801
NC LICENSE NO. C-2871

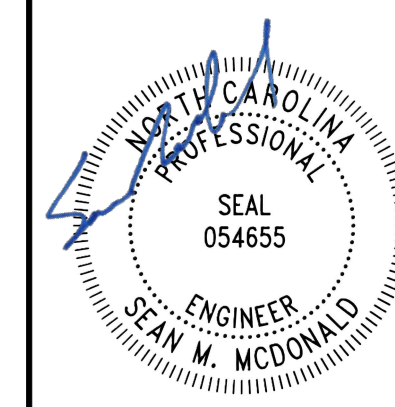

ADDITION STRUCTURAL PLAN DRAWINGS
BUTLER HOMES, LLC C/O STEVEN EISENBERG
185 DEWAR STREET
FUQUAY-VARINA, NC

REVISIONS

NO.	DATE	DESCRIPTION
0	03/12/2024	FOR CONSTRUCTION
1	06/07/2024	REV. 1 - SCREEN PORCH ADDN.
2	12/17/2024	REV. 2 - SP LAYOUT CHANGE

SCALE: AS SHOWN
REVIEWED BY: CAF
DRAWN BY: SMM
DATE: DECEMBER 17, 2024

S1.0

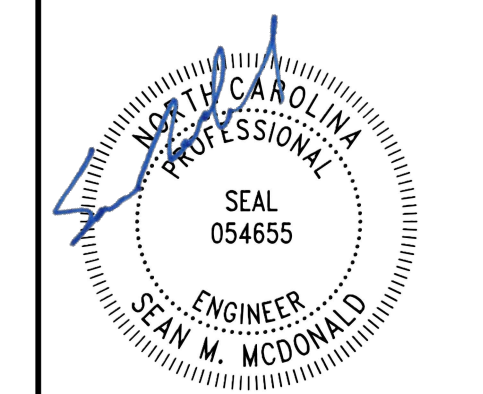
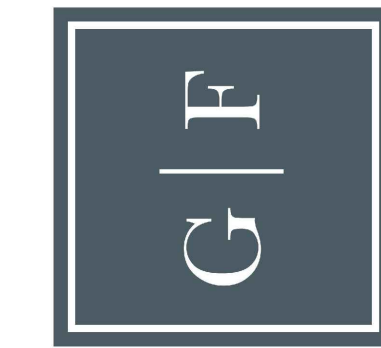

ADDITION STRUCTURAL PLAN DRAWINGS
BUTLER HOMES, LLC C/O STEVEN EISENBERG
185 DEWAR STREET
FUQUAY-VARINA, NC

REVISIONS		
NO.	DATE	DESCRIPTION
0	03/12/2024	FOR CONSTRUCTION
1	06/07/2024	REV. 1 - SCREEN PORCH ADDN.
2	12/17/2024	REV. 2 - SP LAYOUT CHANGE

SCALE: AS SHOWN
REVIEWED BY: CAF
DRAWN BY: SMM
DATE: DECEMBER 17, 2024

S2.0

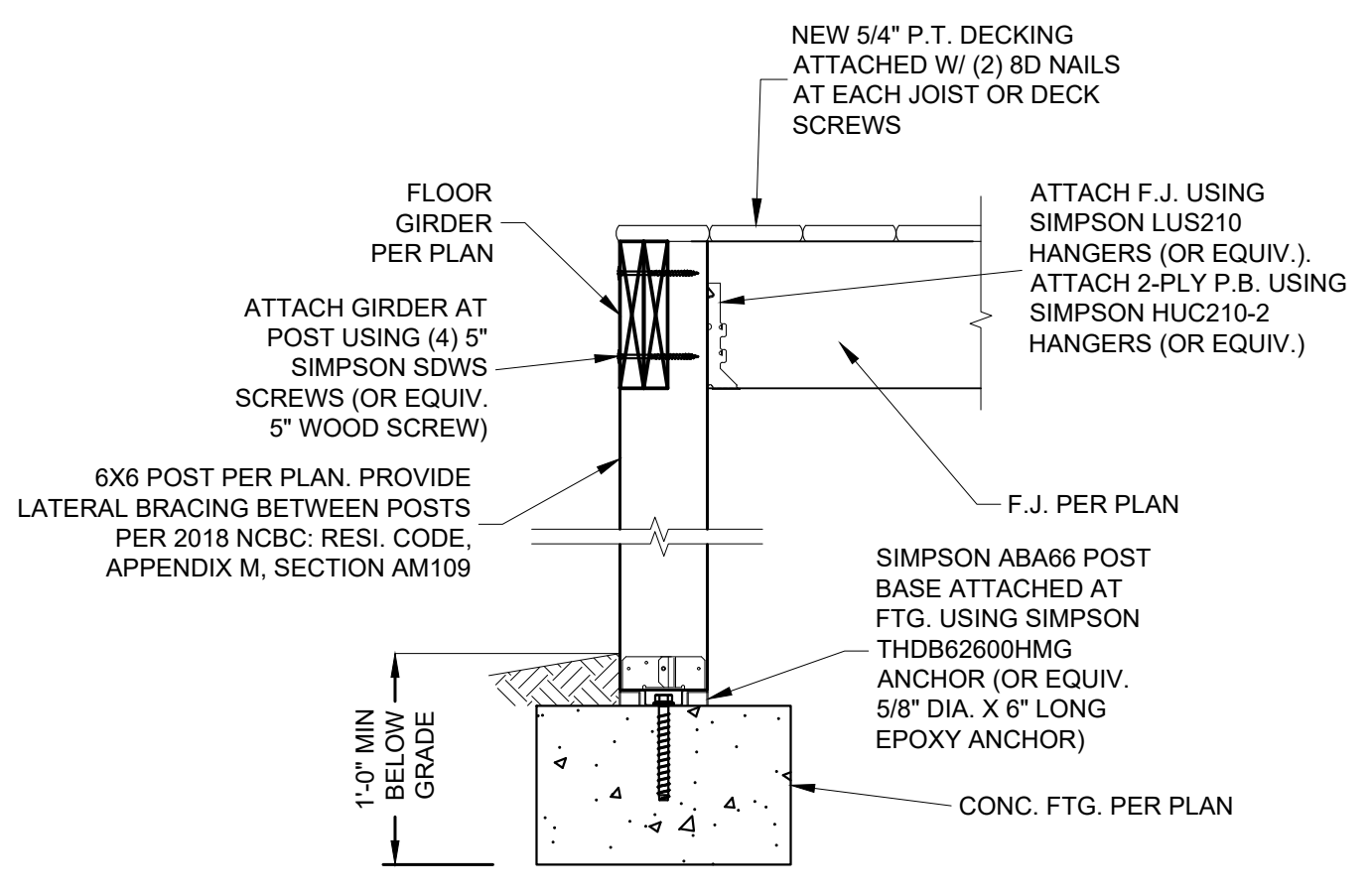

1
S2.0 2-PLY GIRDER AT DECK POST
SCALE: N.T.S.

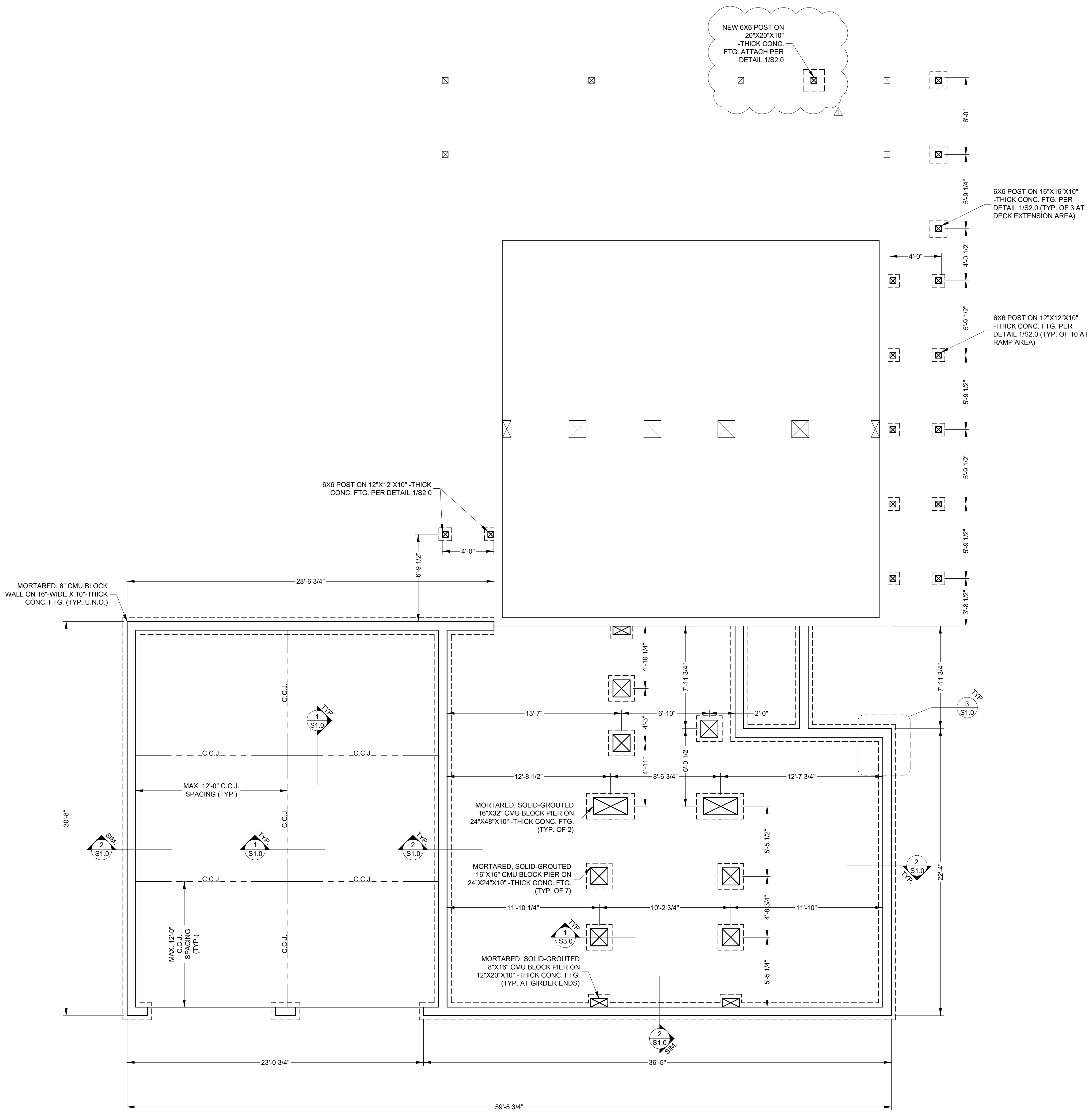

FOUNDATION PLAN
SCALE: 1/4" = 1'-0"

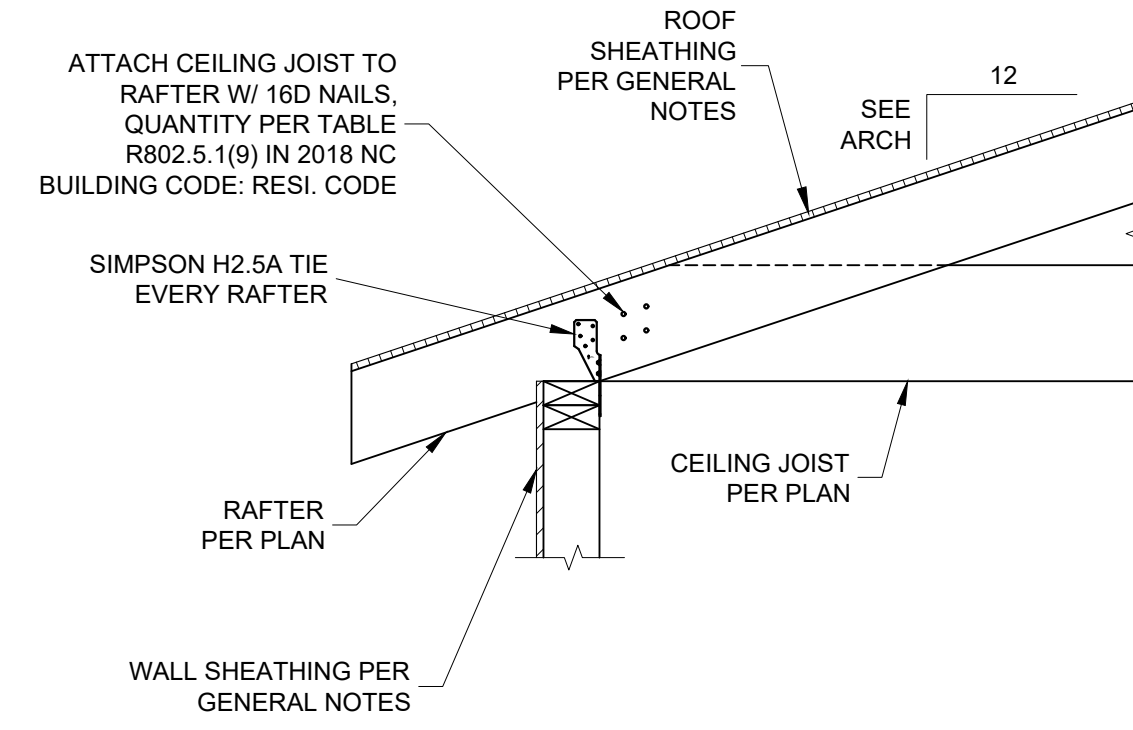

1 TYP. RAFTER BEARING
SCALE: N.T.S.

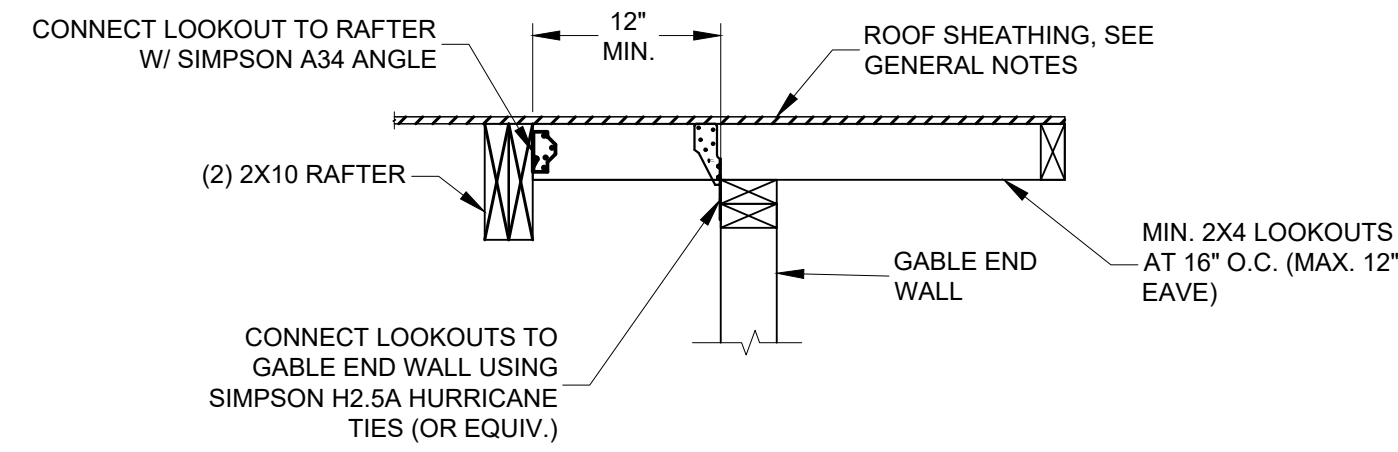

2 TYP. LOOKOUT FRAMING
SCALE: N.T.S.

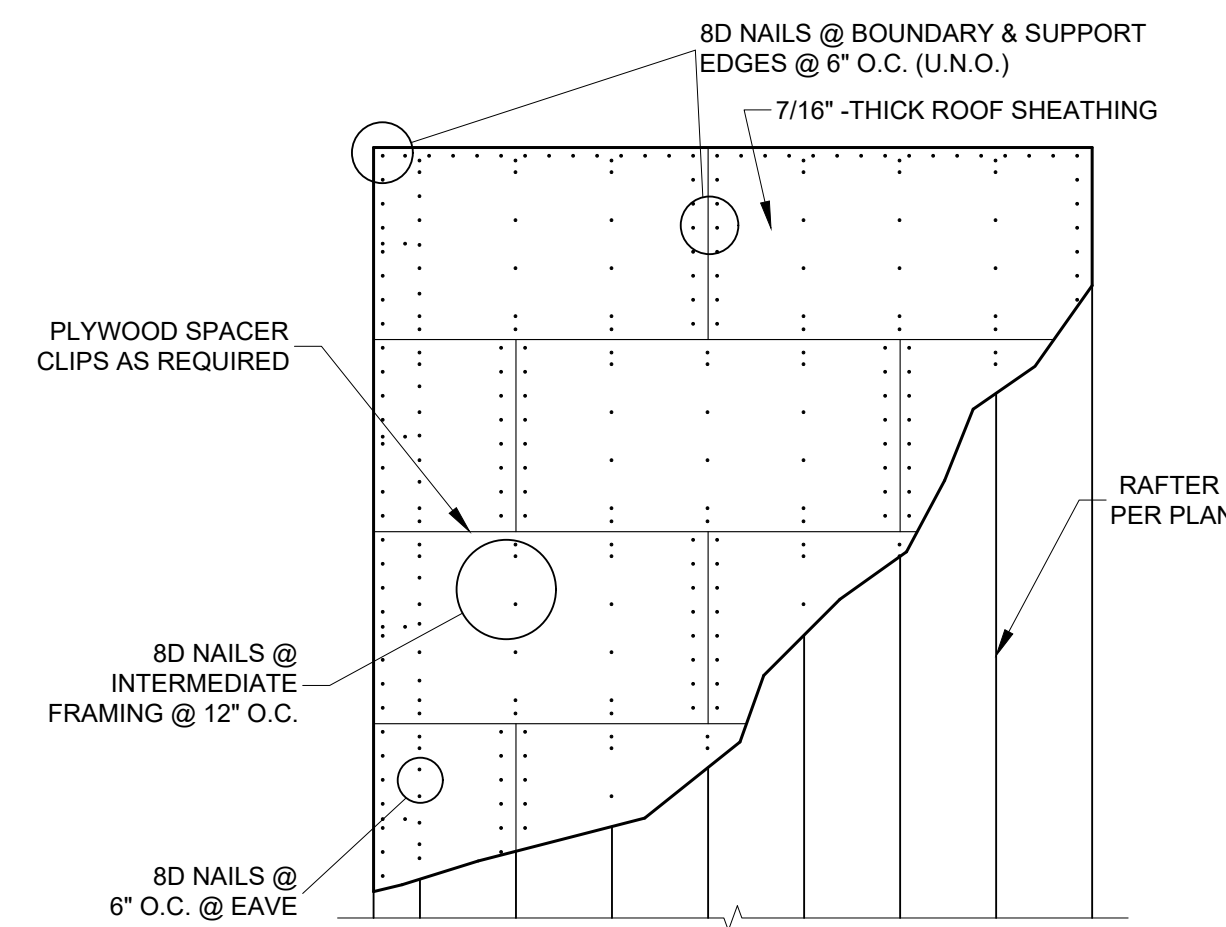

3 TYP. ROOF SHEATHING
SCALE: N.T.S.

PROVIDE 2-PLY MEMBERS AT SKYLIGHT "BOX-OUT" FRAMING. ATTACH FLUSH CONNECTIONS USING SIMPSON LUS210 (SINGLE-PLY), LUS210-2 (DOUBLE-PLY) HANGERS (OR EQUIV.) (TYP. U.N.O.)

AT SOLAR PANEL INSTALLATION LOCATIONS, RAFTER SPANNING GREATER THAN 14'-0" SHALL BE DOUBLED (TYP.)

ROOF SHEATHING PER DETAIL 3/S5.0 (TYP.)

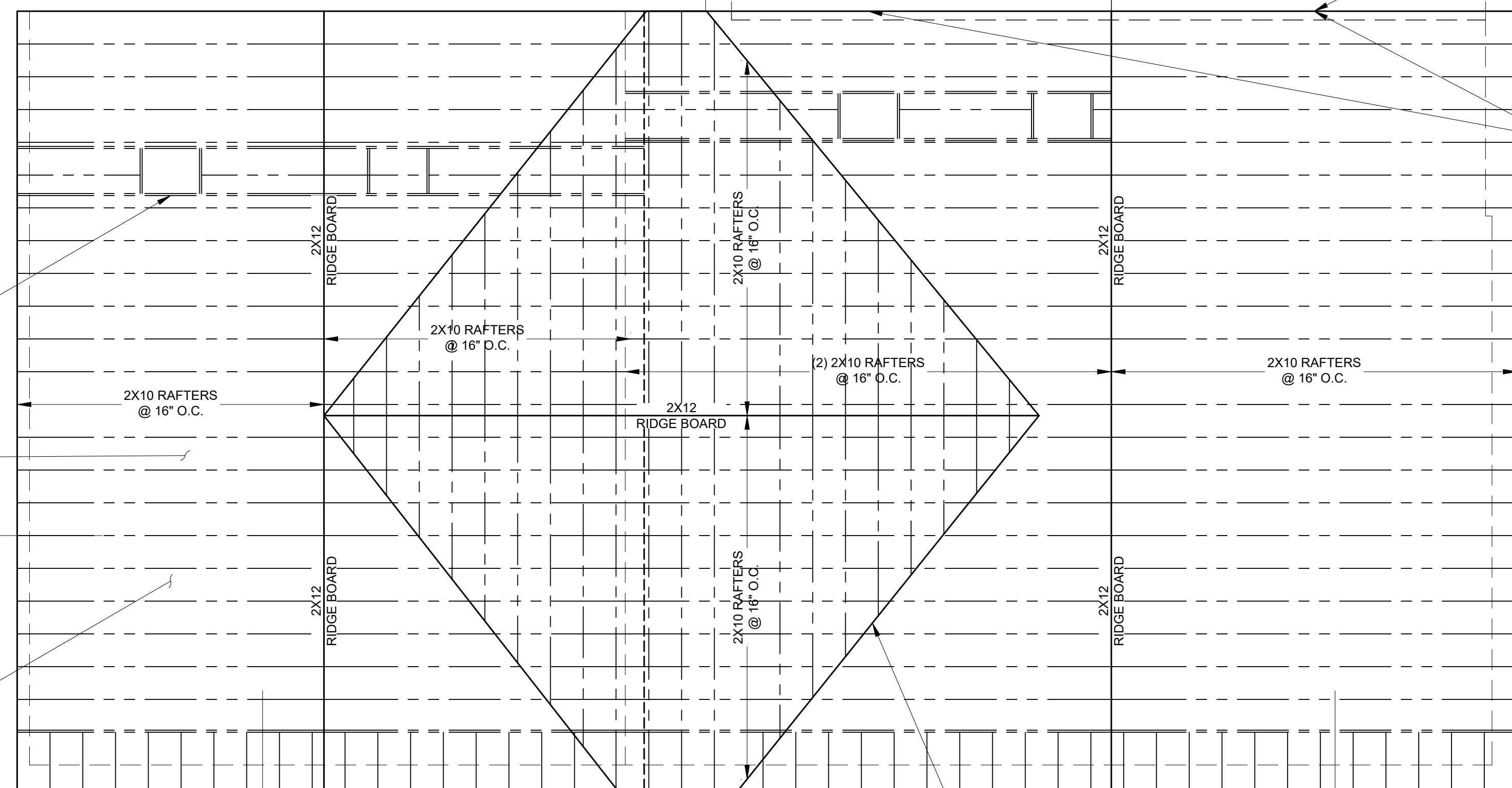

PROVIDE FLAT 2X12 PL. AT ROOF OVERBUILD LOCATIONS FOR RAFTER BEARING. ATTACH AT RAFTERS BELOW USING (3) 3-1/2" SIMPSON SDS SCREWS (OR EQUIV. 3-1/2" WOOD SCREW) @ 16" O.C. (EACH RAFTER). ATTACH RAFTERS TO PL. USING (3) 10D TOENAILS

NEW ROOFLINE. EAVES UP TO 1'-0" PER ARCH. (TYP.)

EX. ROOFLINE TO REMAIN UNMODIFIED (TYP. U.N.O.)

KEY-IN ROOF SHEATHING AT IN-PLANE AREAS B/W ADDITION/EX. STRUCTURE PER SHEATHING DESIGN NOTE #10 (TYP.)

ATTACH GABLE END RAFTERS TO EX. USING (2) 3-1/2" SIMPSON SDS SCREWS (OR EQUIV. 3-1/2" WOOD SCREW) @ 16" O.C.

ATTACH GABLE END RAFTERS TO EX. WALL USING (2) 4-1/2" SIMPSON SDS SCREWS (OR EQUIV. 4-1/2" WOOD SCREW) @ 16" O.C. (EVERY STUD)

2X6 RAFTERS @ 16" O.C.

PROVIDE FLAT 2X8 MEMBER AT ROOF OVERBUILD. ATTACH RAFTERS USING (3) 10D NAILS (TYP.)

OVERBUILD FRAMING: 2X8 RIDGE BOARD W/ 2X6 RAFTERS @ 16" O.C.

ROOF FRAMING PLAN
SCALE: 1/4" = 1'-0"

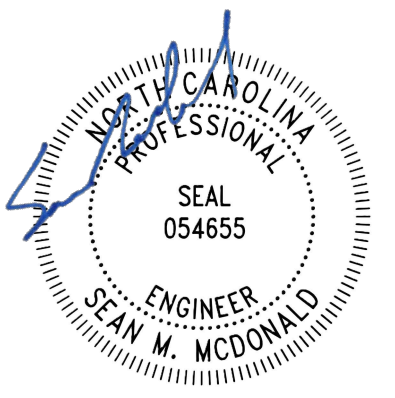

ADDITION STRUCTURAL PLAN DRAWINGS
BUTLER HOMES, LLC C/O STEVEN EISENBERG
185 DEWAR STREET
FUQUAY-VARINA, NC

REVISIONS

NO.	DATE	DESCRIPTION
0	03/12/2024	FOR CONSTRUCTION
1	06/07/2024	REV. 1 - SCREEN PORCH ADDN.
2	12/17/2024	REV. 2 - SP LAYOUT CHANGE

SCALE: AS SHOWN
REVIEWED BY: CAF
DRAWN BY: SMM
DATE: DECEMBER 17, 2024

S5.0