



## STRUCTURAL DESIGN ENCLOSED BUILDING

**MAXIMUM 30'-0" WIDE X 16'- 0" EAVE HEIGHT-  
BOX EAVE FRAME AND BOW FRAME**

6 May 2022

Revision 1

M&A Project No. 20217S/22082S

Prepared for:

Pre-Built Structures  
1330 W Jake Alexander Blvd.  
Salisbury, NC 28417

Prepared by:

Moore and Associates Engineering and Consulting, Inc.  
1009 East Avenue  
North Augusta, SC 29841

401 S. Main Street, Suite 200  
Mount Airy, NC 27030



MOORE AND ASSOCIATES  
ENGINEERING AND CONSULTING

Moore and Associates Engineering and Consulting, Inc. ("Moore & Associates") is the author and owner of all plans, drawings, specifications, etc. ("Instruments of Service") provided by it, and retains all common law, statutory, and other reserved rights, including without limitation copyrights. A limited license is granted to you for use of the Instruments of Service solely and exclusively in connection with the specific project for which the Instruments of Service were created by Moore & Associates. All other uses, including without limitation transfer to a third party, are strictly prohibited. Acceptance of the Instruments of Service constitutes your agreement to indemnify and to hold Moore & Associates harmless from all cost, expenses, damages, and attorney's fees arising from or relating to any unauthorized use or transfer of the Instruments of Service.

MOORE AND ASSOCIATES  
ENGINEERING AND CONSULTING, INC.

DRAWN BY: LT

CHECKED BY: PDH

PROJECT MGR: WSH

CLIENT: PRE-BUILT

PRE-BUILT STRUCTURES  
1330 W JAKE ALEXANDER BLVD.  
SALISBURY, NC 28417  
30'-0" x 16'-0" ENCLOSED STRUCTURE

DATE: 5-6-22      SCALE: NTS      JOB NO: 20217S/22082S

SHT. 1      DWG. NO: SK-3      REV. 1

THIS DOCUMENT IS THE PROPERTY OF MOORE AND ASSOCIATES ENGINEERING AND CONSULTING. THE UNAUTHORIZED REPRODUCTION, COPYING, OR OTHERWISE USE OF THIS DOCUMENT IS STRICTLY PROHIBITED AND ANY INFRINGEMENT THEREUPON MAY BE SUBJECT TO LEGAL ACTION.



# DRAWING INDEX

SHEET 1	PE SEAL COVER SHEET
SHEET 2	DRAWING INDEX
SHEET 3	INSTALLATION NOTES AND SPECIFICATIONS
SHEET 3A	LIST OF APPLICABLE BUILDING CODES
SHEET 4	TYPICAL SIDE AND END ELEVATIONS
SHEET 5	TYPICAL RAFTER/COLUMN FRAME AND SIDE FRAMING SECTION (BOX EAVE RAFTER)
SHEET 6	COLUMN CONNECTION DETAILS (BOX EAVE RAFTER)
SHEET 6A	COLUMN CONNECTION DETAILS (BOX EAVE RAFTER)
SHEET 7	TYPICAL RAFTER/COLUMN FRAME AND SIDE FRAMING SECTION (BOW EAVE RAFTER)
SHEET 8	COLUMN CONNECTION DETAILS (BOW EAVE RAFTER)
SHEET 8A	COLUMN CONNECTION DETAILS (BOW EAVE RAFTER)
SHEET 9	BASE RAIL ANCHORAGE OPTIONS
SHEET 10	TYPICAL END WALL AND SIDE WALL FRAMING SECTIONS (BOX EAVE RAFTER)
SHEET 11	TYPICAL END WALL AND SIDE WALL FRAMING SECTIONS (BOW EAVE RAFTER)
SHEET 12	CONNECTION DETAILS
SHEET 13	CONNECTION DETAILS
SHEET 14	LEAN-TO OPTIONS (BOX EAVE RAFTER)
SHEET 15	LEAN-TO OPTIONS (BOW EAVE RAFTER)
SHEET 16	VERTICAL ROOF/SIDING OPTION END AND SIDE ELEVATION AND SECTION (BOX EAVE RAFTER)
SHEET 17	SIDE WALL AND END WALL HEADER OPTIONS

PRE-BUILT STRUCTURES  
 QUALITY THAT PUTS BEST  
 FOR CUSTOMER USE ONLY CHAD CONKLIN

<b>MOORE AND ASSOCIATES ENGINEERING AND CONSULTING, INC.</b>	DRAWN BY: LT	PRE-BUILT STRUCTURES 1330 W JAKE ALEXANDER BLVD. SALISBURY, NC 28417 30'-0" x 16'-0" ENCLOSED STRUCTURE		
	CHECKED BY: PDH			
THIS DOCUMENT IS THE PROPERTY OF MOORE AND ASSOCIATES ENGINEERING AND CONSULTING. THE UNAUTHORIZED REPRODUCTION, COPYING, OR OTHERWISE USE OF THIS DOCUMENT IS STRICTLY PROHIBITED AND ANY INFRINGEMENT THEREUPON MAY BE SUBJECT TO LEGAL ACTION.	PROJECT MGR: WSM	DATE: 5-6-22	SCALE: NTS	JOB NO: 20217S/22082S
	CLIENT: PRE-BUILT	SHT. 2	DVG. NO: SK-3	REV. 1

## INSTALLATION NOTES AND SPECIFICATIONS

1. DESIGN IS FOR MAXIMUM 30'-0" WIDE x 16'-0" EAVE HEIGHT ENCLOSED STRUCTURES.
2. DESIGN WAS DONE IN ACCORDANCE WITH ALL THE APPLICABLE BUILDING CODES LISTED ON SHEET 3A.
3. DESIGN LOADS ARE AS FOLLOWS:

A) ROOF DEAD LOADS:

SELF-WEIGHT = 1.5 PSF  
 MEP = 0 PSF  
 COLLATERAL = 0 PSF

B) ROOF LIVE LOAD = 12 PSF

C) FLOOR LIVE LOAD = 100 PSF (4" CONCRETE SLAB/FOOTING)

D) GROUND SNOW LOAD = 35 PSF

= 30 PSF (WITH U-CHANNEL RAFTER TIE)

NOTE: UNBALANCED LOADING DUE TO SNOW DRIFTING FROM AN ADJACENT TALLER STRUCTURE HAS NOT BEEN EVALUATED.

4. 3-SECOND GUST ULTIMATE WIND SPEED ( $V_{ULT}$ ) =  $\leq$  145 MPH (NOMINAL WIND SPEED =  $\leq$  112 MPH).
5. MAXIMUM RAFTER/COLUMN AND END COLUMN SPACING = 5.0 FEET (UNLESS NOTED OTHERWISE).
6. ENDWALL COLUMNS (POSTS) AND SIDE WALL COLUMNS ARE EQUIVALENT IN SIZE AND SPACING (UNLESS NOTED OTHERWISE).
7. RISK CATEGORY I (NOT FOR HUMAN HABITATION).
8. WIND EXPOSURE CATEGORY B.
9. SPECIFICATIONS APPLICABLE TO 29 GAUGE METAL PANELS FASTENED DIRECTLY TO 2 1/2"x2 1/2"-14 GAUGE TUBE STEEL (TS) FRAMING MEMBERS (UNLESS NOTED OTHERWISE). 2 1/4"x2 1/4"-12 GAUGE TS MAY BE USED AS OPTIONAL FRAMING MEMBERS.
10. CONNECTOR SLEEVES ARE MINIMUM 6' LONG, TS 2 1/4"x2 1/4"-14 GAUGE FOR 2 1/2"x2 1/2"-14 GAUGE AND TS 2"x2"-12 GAUGE FOR 2 1/4"x2 1/4"-12 GAUGE FRAMING MEMBERS (UNLESS NOTED OTHERWISE).
11. STRUCTURAL ANALYSIS/DESIGN IS BASED ON TS MEETING THE REQUIREMENTS OF ASTM A653 GRADE 50 WITH MINIMUM YIELD STRENGTH ( $F_y$ ) OF 54 KSI AND GALVANIZING MEETING THE MINIMUM REQUIREMENTS OF G60.
12. AVERAGE PANEL FASTENER SPACING ON-CENTERS = 10 INCHES.
13. FASTENERS CONSIST OF #12-14x3/4" SELF-DRILLING FASTENER (SDF), USE CONTROL SEAL WASHER WITH EXTERIOR FASTENERS. SPECIFICATIONS APPLICABLE ONLY FOR MEAN ROOF HEIGHT OF 16 FEET OR LESS, AND ROOF SLOPES OF 14° (3:12 PITCH) OR LESS. SPACING REQUIREMENTS FOR OTHER ROOF HEIGHTS AND/OR SLOPES MAY VARY. ROOF SLOPES LESS THAN 3:12 REQUIRE USE OF JOINT SEALANT.
14. ANCHORS SHALL BE INSTALLED THROUGH BASE RAIL WITHIN 6' OF EACH COLUMN.
15. STANDARD GROUND ANCHORS (SOIL NAILS) CONSIST OF #4 REBAR W/ WELDED NUT x 30" LONG AND MAY ONLY BE USED IN CONJUNCTION WITH OTHER (OPTIONAL) ANCHOR DEVICES AND ONLY IN SUITABLE SOILS. OPTIONAL ANCHORAGE MAY BE USED IN SUITABLE SOILS AND MUST BE USED IN UNSUITABLE SOILS AS NOTED. COORDINATE WITH LOCAL CODES/ORDINANCES REGARDING MINIMUM LENGTH FOR FROST DEPTH PROTECTION.
16. CONTRACTOR TO PROVIDE ADEQUATE BRACING FOR STRUCTURE SO THAT IT WILL BE STABLE DURING ALL STAGES OF CONSTRUCTION. THE STRUCTURE AND FOUNDATION ARE DESIGNED FOR A COMPLETED CONDITION ONLY AND, THEREFORE, REQUIRE ADDITIONAL SUPPORT TO MAINTAIN STABILITY BEFORE COMPLETION.
17. WIND FORCES GOVERN OVER SEISMIC FORCES. SEISMIC PARAMETERS ANALYZED ARE:  
 SOIL SITE CLASS = D  
 RISK CATEGORY I  
 $R = 3.25$                        $I_g = 1.0$   
 $S_{DS} = 2.625 g$                  $V = C_s W$   
 $S_{M1} = 2.13 g$
18. IF MORE THAN 50% OF COLUMN (LEG) ARE REMOVED IN ANY LONGITUDINAL (SIDE) WALLS OF A BUILDING, THE ENGINEER IS TO BE NOTIFIED TO DETERMINE WHETHER PORTAL FRAMES OR OTHER LONGITUDINAL STABILITY ELEMENTS WILL BE REQUIRED.
19. THIS MASTER DESIGN IS A GENERIC MASTER DESIGN PRIMARILY INTENDED FOR PLANT FABRICATION AND ERECTION AKIN TO SHOP DRAWINGS. THE MASTER DESIGN IS NOT PRIMARILY INTENDED FOR CONSTRUCTION PERMIT. WHEN APPLYING FOR BUILDING PERMIT, THE CERTIFIED BUILDING OFFICIAL MUST BE CONSULTED TO VERIFY WHETHER THE USE OF THE MASTER DESIGN IS ADEQUATE OR IF A SITE-SPECIFIC DESIGN IS REQUIRED FOR BUILDING PERMIT. ANY VARIATION FROM THE ANALYSIS/DESIGN PARAMETERS OF THE MASTER DESIGN REQUIRES THE DEVELOPMENT OF A SITE-SPECIFIC DESIGN.

**MOORE AND ASSOCIATES  
 ENGINEERING AND CONSULTING, INC.**

DRAWN BY: LT

CHECKED BY: PDH

PROJECT MGR: VSM

CLIENT: PRE-BUILT

PRE-BUILT STRUCTURES

1330 W JAKE ALEXANDER BLVD.

SALISBURY, NC 28417

30'-0" x 16'-0" ENCLOSED STRUCTURE

DATE: 5-6-22

SCALE: NTS

JOB NO:

202175/220825

SHT. 3

DWG. NO: SK-3

REV: 1

THIS DOCUMENT IS THE PROPERTY OF MOORE AND ASSOCIATES ENGINEERING AND CONSULTING. THE UNAUTHORIZED REPRODUCTION, COPYING, OR OTHERWISE USE OF THIS DOCUMENT IS STRICTLY PROHIBITED AND ANY INFRINGEMENT THEREUPON MAY BE SUBJECT TO LEGAL ACTION.



**LIST OF APPLICABLE BUILDING CODES**

- 2018 INTERNATIONAL BUILDING CODE (IBC 2018)
- 2015 INTERNATIONAL BUILDING CODE (IBC 2015)
- 2012 INTERNATIONAL BUILDING CODE (IBC 2012)
- GEORGIA STATE MINIMUM STANDARD BUILDING CODE  
(ADOPTS THE IBC 2018 WITH AMENDMENTS)
- 2018 NORTH CAROLINA BUILDING CODE  
(ADOPTS THE IBC 2015 WITH AMENDMENTS)
- 2018 SOUTH CAROLINA BUILDING CODE  
(ADOPTS THE IBC 2018 WITH AMENDMENTS)
- BUILDING CODE 2012 OF TENNESSEE  
(ADOPTS THE IBC 2012 WITH AMENDMENTS)  
BUILDING CODE 2018 OF NASHVILLE AND DAVIDSON  
COUNTY (ADOPTS THE IBC 2018 WITH AMENDMENTS)
- 2018 VIRGINIA CONSTRUCTION CODE  
(ADOPTS THE IBC 2018 WITH AMENDMENTS)

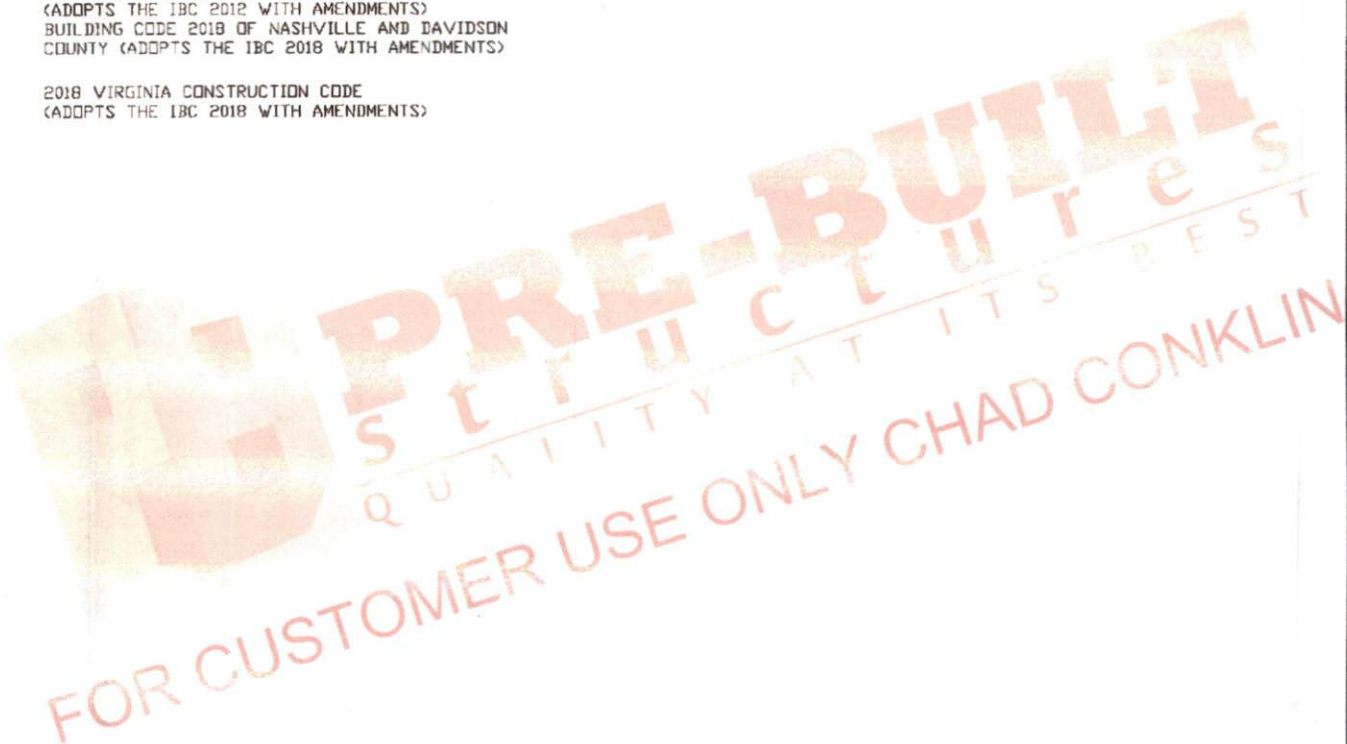

**MOORE AND ASSOCIATES  
ENGINEERING AND CONSULTING, INC.**

**DRAWN BY: LT**  
**CHECKED BY: PDH**

PRE-BUILT STRUCTURES  
1330 W JAKE ALEXANDER BLVD.  
SALISBURY, NC 28417  
30'-0" x 16'-0" ENCLOSED STRUCTURE

THIS DOCUMENT IS THE PROPERTY OF MOORE AND ASSOCIATES ENGINEERING AND CONSULTING. THE UNAUTHORIZED REPRODUCTION, COPYING, OR OTHERWISE USE OF THIS DOCUMENT IS STRICTLY PROHIBITED AND ANY INFRINGEMENT THEREUPON MAY BE SUBJECT TO LEGAL ACTION.

**PROJECT MGR: VSM**  
**CLIENT: PRE-BUILT**

<b>DATE: 5-6-22</b>	<b>SCALE: NTS</b>	<b>JOB NO: 2021S/22002S</b>
<b>SHT. 3A</b>	<b>DWG. NO SK-3</b>	<b>REV. 1</b>

### BOX EAVE FRAME RAFTER STRUCTURE

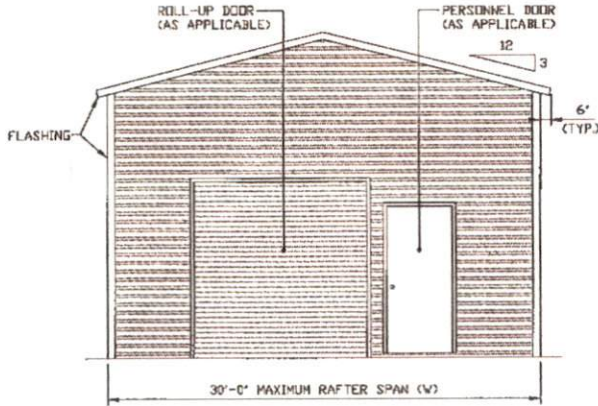

**TYPICAL END ELEVATION**

SCALE: NTS

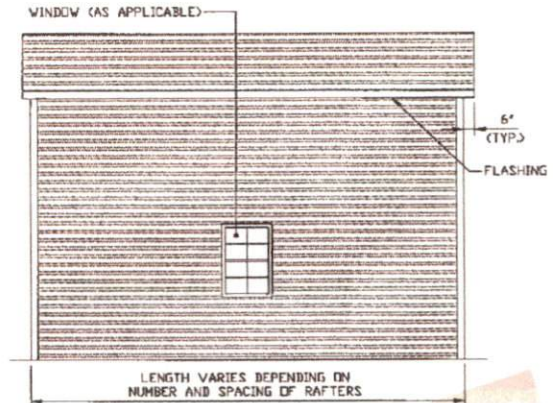

**TYPICAL SIDE ELEVATION**

SCALE: NTS

### BOW EAVE FRAME RAFTER STRUCTURE

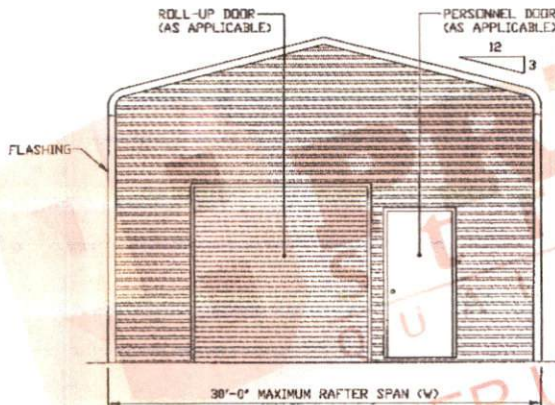

**TYPICAL END ELEVATION**

SCALE: NTS

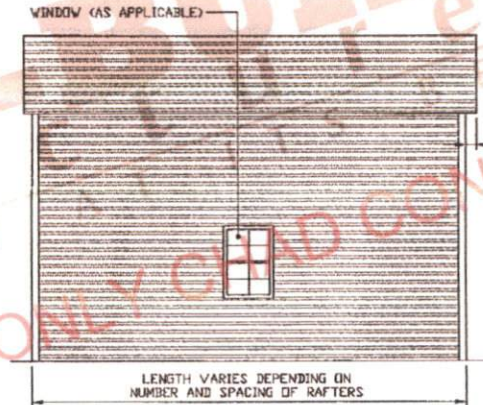

**TYPICAL SIDE ELEVATION**

SCALE: NTS

**MOORE AND ASSOCIATES  
ENGINEERING AND CONSULTING, INC.**

DRAWN BY: LT

CHECKED BY: PDH

PROJECT MGR: VSM

CLIENT: PRE-BUILT

PRE-BUILT STRUCTURES  
1330 W JAKE ALEXANDER BLVD.  
SALISBURY, NC 28417  
30'-0" x 16'-0" ENCLOSED STRUCTURE

DATE: 5-6-22

SHT. 4

SCALE: NTS

DWG. NO: SK-3

JOB NO:  
20217S/22082S

REV: 1

THIS DOCUMENT IS THE PROPERTY OF MOORE AND ASSOCIATES ENGINEERING AND CONSULTING. THE UNAUTHORIZED REPRODUCTION, COPYING, OR OTHERWISE USE OF THIS DOCUMENT IS STRICTLY PROHIBITED AND ANY INFRINGEMENT THEREUPON MAY BE SUBJECT TO LEGAL ACTION.



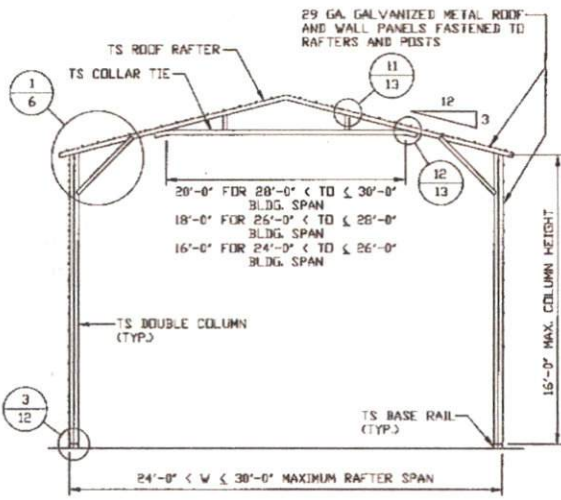

**TYPICAL RAFTER/COLUMN FRAME SECTION**  
SCALE: NTS

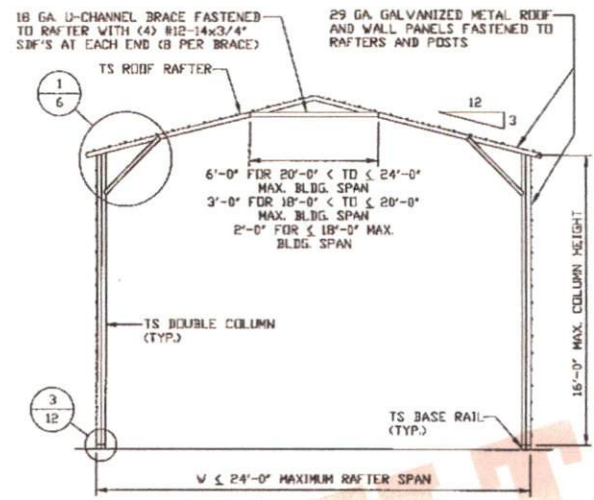

**TYPICAL RAFTER/COLUMN FRAME SECTION**  
SCALE: NTS

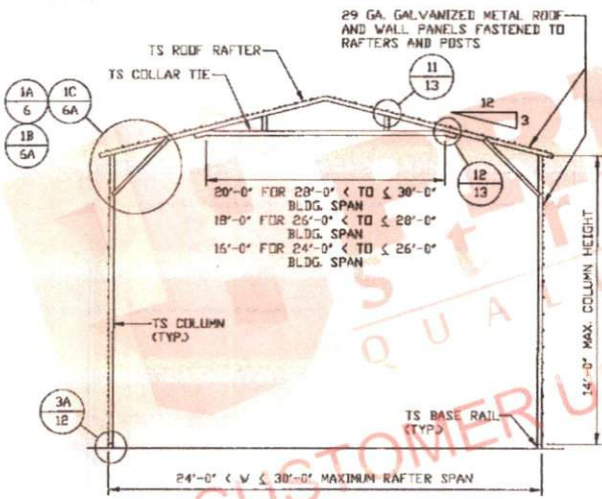

**TYPICAL RAFTER/COLUMN FRAME SECTION**  
SCALE: NTS

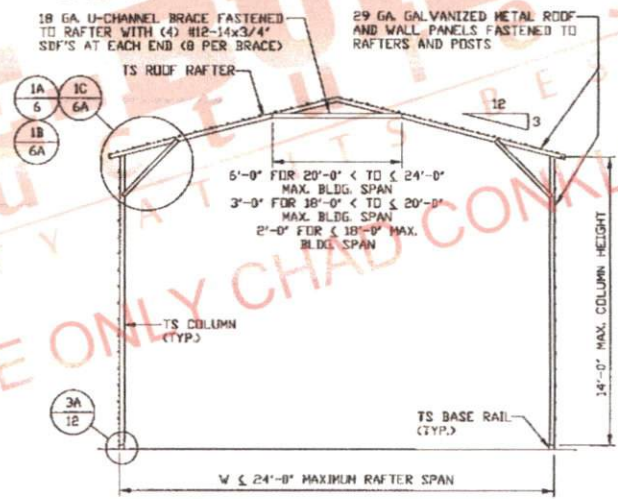

**TYPICAL RAFTER/COLUMN FRAME SECTION**  
SCALE: NTS

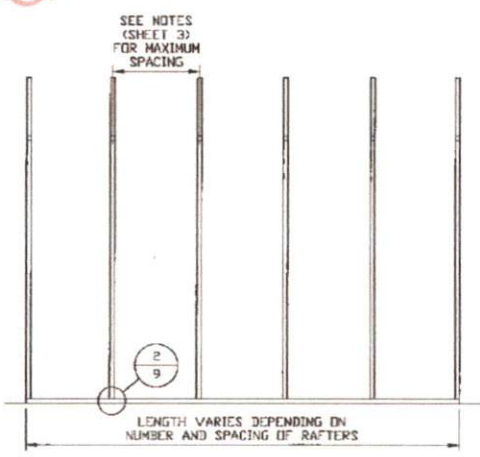

**TYPICAL RAFTER/COLUMN SIDE FRAMING SECTION**  
SCALE: NTS

**MOORE AND ASSOCIATES  
ENGINEERING AND CONSULTING, INC.**

DRAWN BY: LT  
CHECKED BY: PDH  
PROJECT MGR: VSM  
CLIENT: PRE-BUILT

PRE-BUILT STRUCTURES  
1330 W JAKE ALEXANDER BLVD.  
SALISBURY, NC 28417  
30'-0"x16'-0" ENCLOSED STRUCTURE

DATE: 5-6-22  
SCALE: NTS  
DVG. NO: SK-3

JOB NO: 20217S/22092S  
REV: 1

THIS DOCUMENT IS THE PROPERTY OF MOORE AND ASSOCIATES ENGINEERING AND CONSULTING. THE UNAUTHORIZED REPRODUCTION, COPYING, OR OTHERWISE USE OF THIS DOCUMENT IS STRICTLY PROHIBITED AND ANY INFRINGEMENT THEREUPON MAY BE SUBJECT TO LEGAL ACTION.

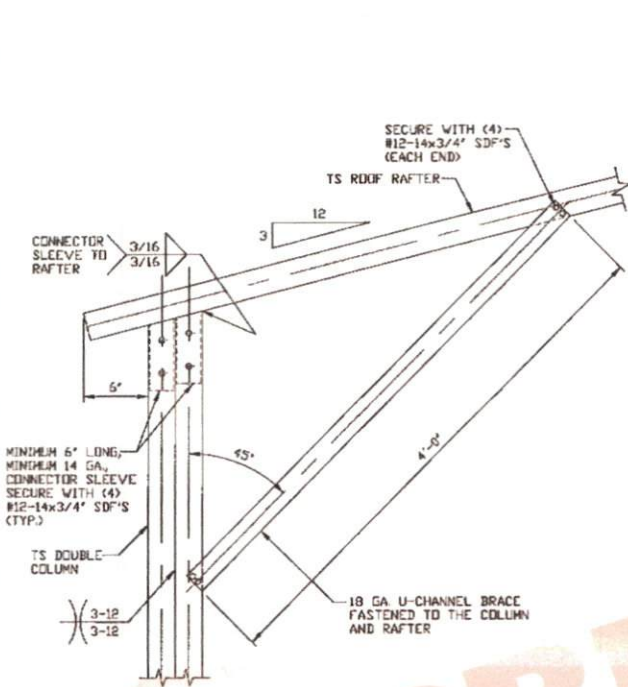

**1**  
**BOX EAVE RAFTER/CORNER POST CONNECTION DETAIL**  
**FOR HEIGHTS 14'-0" < TO ≤ 16'-0"**  
 SCALE: NTS

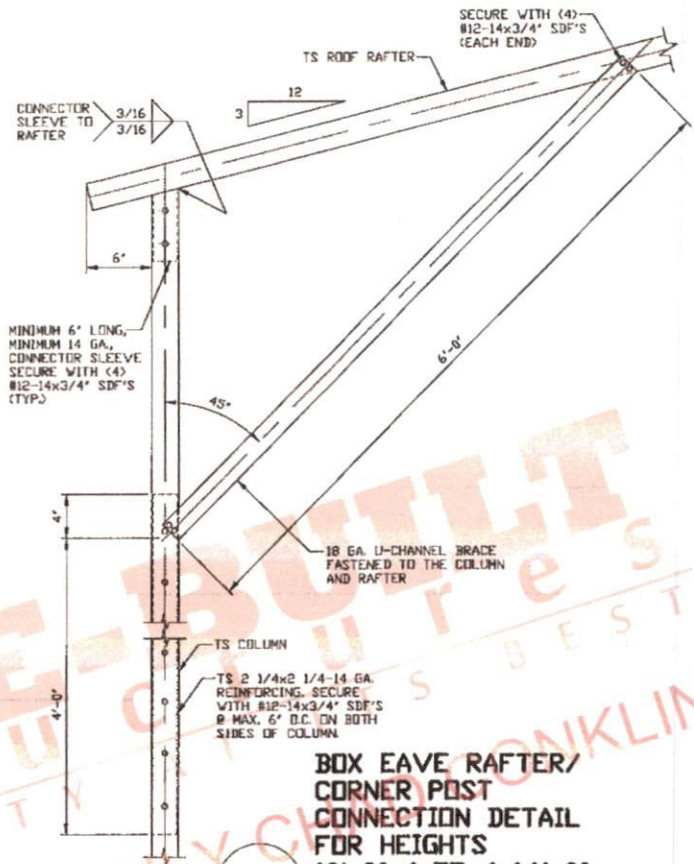

**1A**  
**BOX EAVE RAFTER/CORNER POST CONNECTION DETAIL**  
**FOR HEIGHTS 10'-0" < TO ≤ 14'-0"**  
 SCALE: NTS

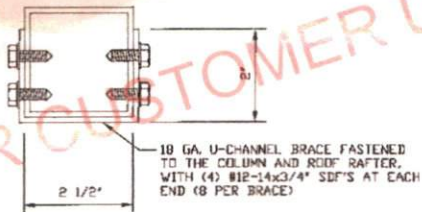

**BRACE SECTION**  
 SCALE: NTS

**MOORE AND ASSOCIATES ENGINEERING AND CONSULTING, INC.**

**DRAWN BY: LT**  
**CHECKED BY: PDH**  
**PROJECT MGR: VSM**  
**CLIENT: PRE-BUILT**

**PRE-BUILT STRUCTURES**  
 1330 W JAKE ALEXANDER BLVD.  
 SALISBURY, NC 28417  
 30'-0" x 16'-0" ENCLOSED STRUCTURE  
**DATE: 5-6-22**  
**SCALE: NTS**  
**SHT. 6**  
**JOB NO: 20217S/22082S**  
**DWG. NO: SK-3**  
**REV: 1**

THIS DOCUMENT IS THE PROPERTY OF MOORE AND ASSOCIATES ENGINEERING AND CONSULTING. THE UNAUTHORIZED REPRODUCTION, COPYING, OR OTHERWISE USE OF THIS DOCUMENT IS STRICTLY PROHIBITED AND ANY INFRINGEMENT THEREUPON MAY BE SUBJECT TO LEGAL ACTION.



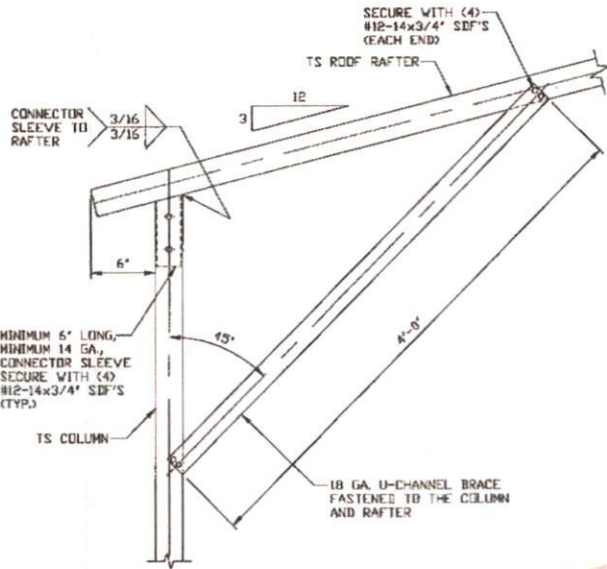

1B

**BOX EAVE RAFTER/CORNER POST CONNECTION DETAIL FOR HEIGHTS 8'-0" < TO ≤ 10'-0"**

SCALE: NTS

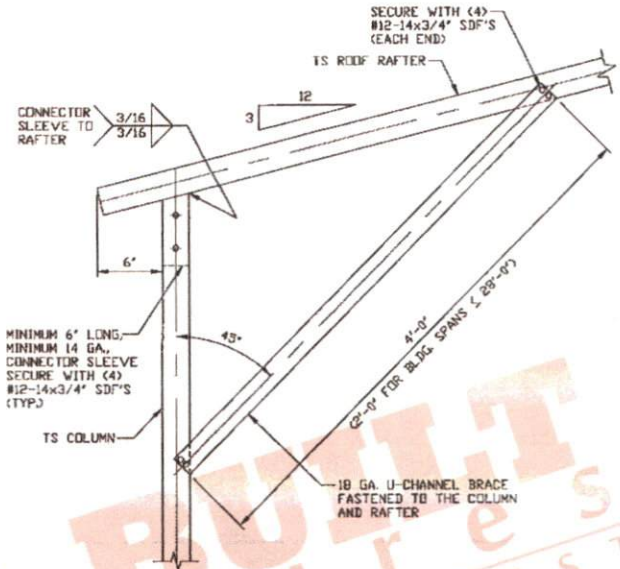

1C

**BOX EAVE RAFTER/CORNER POST CONNECTION DETAIL FOR HEIGHTS ≤ 8'-0"**

SCALE: NTS

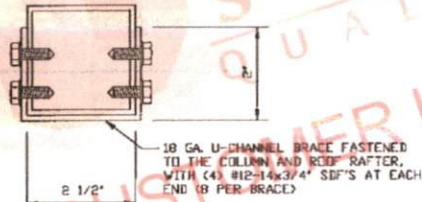

**BRACE SECTION**

SCALE: NTS

**MOORE AND ASSOCIATES  
ENGINEERING AND CONSULTING, INC.**

**DRAWN BY: LT**  
**CHECKED BY: PDH**

**PRE-BUILT STRUCTURES**  
1330 W JAKE ALEXANDER BLVD.  
SALISBURY, NC 28417  
30'-0" x 16'-0" ENCLOSED STRUCTURE

THIS DOCUMENT IS THE PROPERTY OF MOORE AND ASSOCIATES ENGINEERING AND CONSULTING. THE UNAUTHORIZED REPRODUCTION, COPYING, OR OTHERWISE USE OF THIS DOCUMENT IS STRICTLY PROHIBITED AND ANY INFRINGEMENT THEREUPON MAY BE SUBJECT TO LEGAL ACTION.

**PROJECT NBR: VSM**  
**CLIENT: PRE-BUILT**

**DATE: 5-6-22**  
**SHT. 6A**

**SCALE: NTS**  
**DWG. NO: SK-3**

**JOB NO: 20217S/P2082S**  
**REV: 1**

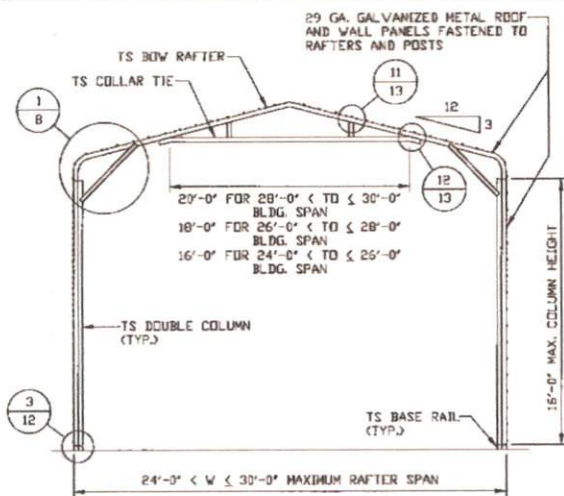

**TYPICAL RAFTER/COLUMN FRAME SECTION**  
SCALE: NTS

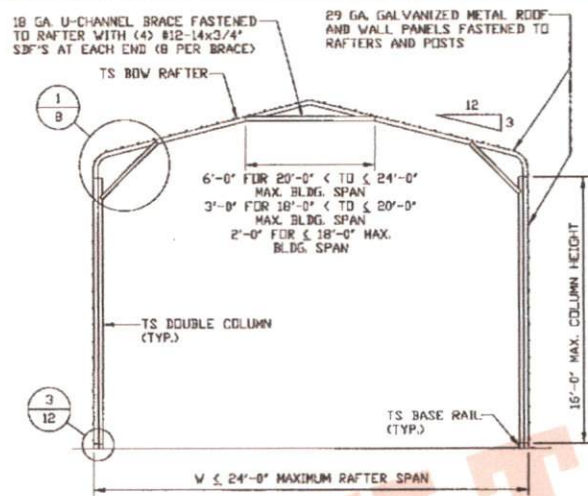

**TYPICAL RAFTER/COLUMN FRAME SECTION**  
SCALE: NTS

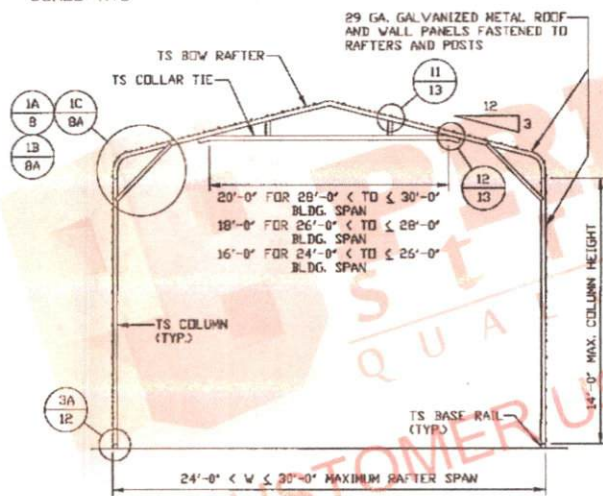

**TYPICAL RAFTER/COLUMN FRAME SECTION**  
SCALE: NTS

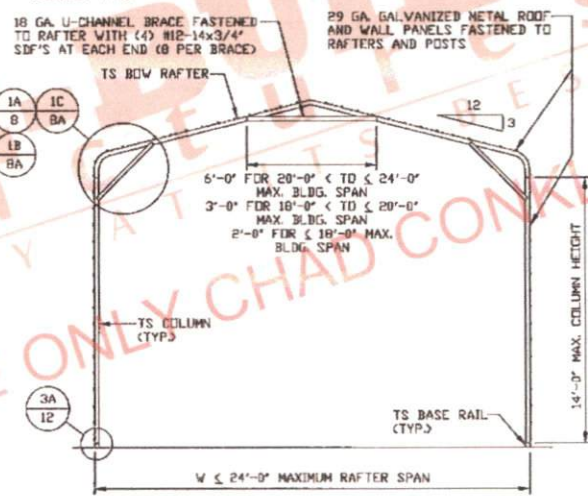

**TYPICAL RAFTER/COLUMN FRAME SECTION**  
SCALE: NTS

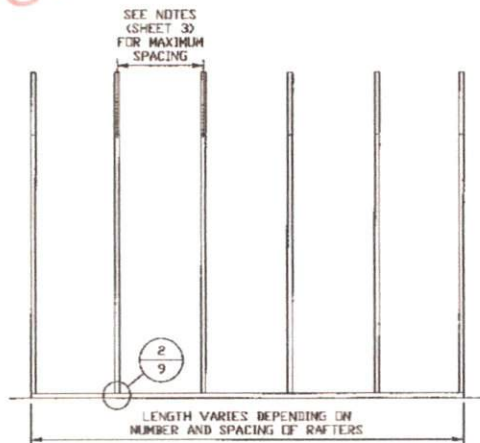

**TYPICAL RAFTER/COLUMN SIDE FRAMING SECTION**  
SCALE: NTS

**MOORE AND ASSOCIATES  
ENGINEERING AND CONSULTING, INC.**

**DRAWN BY: LT**

**CHECKED BY: PDH**

**PROJECT MGR: VSM**

**CLIENT: PRE-BUILT**

**PRE-BUILT STRUCTURES**  
1330 W JAKE ALEXANDER BLVD.  
SALISBURY, NC 28417  
30'-0"x16'-0" ENCLOSED STRUCTURE

**DATE: 5-6-22**

**SHT. 7**

**SCALE: NTS**

**DWG. NO: SK-3**

**JOB NO:**  
202175/22062S

**REV: 1**

THIS DOCUMENT IS THE PROPERTY OF MOORE AND ASSOCIATES ENGINEERING AND CONSULTING. THE UNAUTHORIZED REPRODUCTION, COPYING, OR OTHERWISE USE OF THIS DOCUMENT IS STRICTLY PROHIBITED AND ANY INFRINGEMENT THEREUPON MAY BE SUBJECT TO LEGAL ACTION.



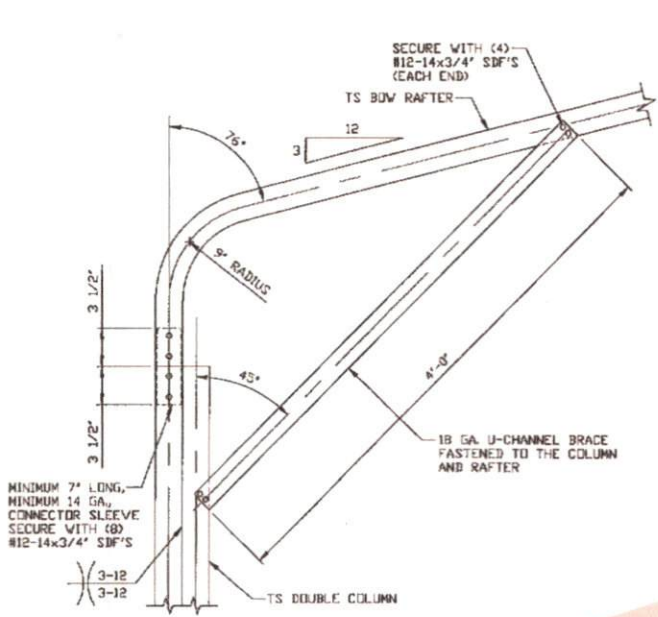

**BOW EAVE RAFTER/CORNER POST CONNECTION DETAIL FOR HEIGHTS 14'-0" < TO <= 16'-0"**  
SCALE: NTS

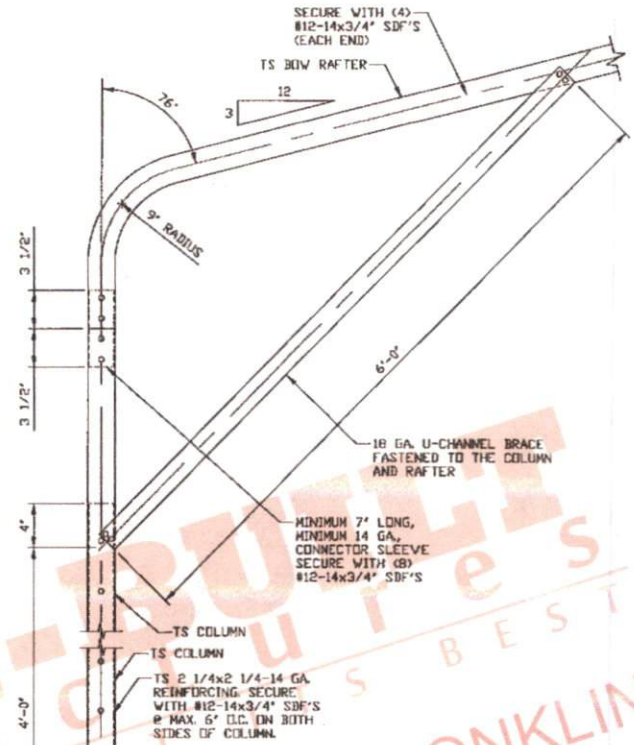

**BOW EAVE RAFTER/CORNER POST CONNECTION DETAIL FOR HEIGHTS 10'-0" < TO <= 14'-0"**  
SCALE: NTS

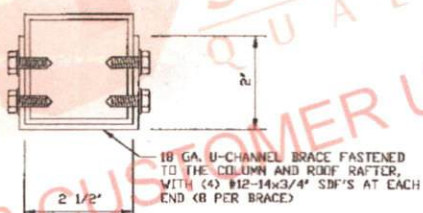

**BRACE SECTION**  
SCALE: NTS

PRE-BUILT STRUCTURES  
 QUALITY CUSTOMER USE ONLY  
 CONKLIN'S BEST

<b>MOORE AND ASSOCIATES ENGINEERING AND CONSULTING, INC.</b>	DRAWN BY: LT	PRE-BUILT STRUCTURES 1330 W JAKE ALEXANDER BLVD. SALISBURY, NC 28417 30'-0" x 16'-0" ENCLOSED STRUCTURE		
	CHECKED BY: PDH			
PROJECT MGR: WSM	DATE: 5-6-22	SCALE: NTS	JOB NO: 20217S/22082S	
CLIENT: PRE-BUILT	SHT. 8	DVG. NO SK-3	REV: 1	

THIS DOCUMENT IS THE PROPERTY OF MOORE AND ASSOCIATES ENGINEERING AND CONSULTING. THE UNAUTHORIZED REPRODUCTION, COPYING, OR OTHERWISE USE OF THIS DOCUMENT IS STRICTLY PROHIBITED AND ANY INFRINGEMENT THEREUPON MAY BE SUBJECT TO LEGAL ACTION.

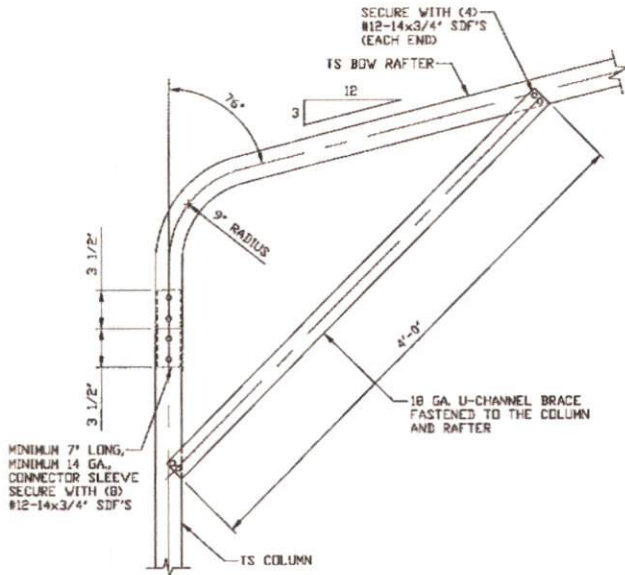

1B

**BOW EAVE RAFTER/CORNER POST CONNECTION DETAIL FOR HEIGHTS 8'-0" < TO ≤ 10'-0"**

SCALE: NTS

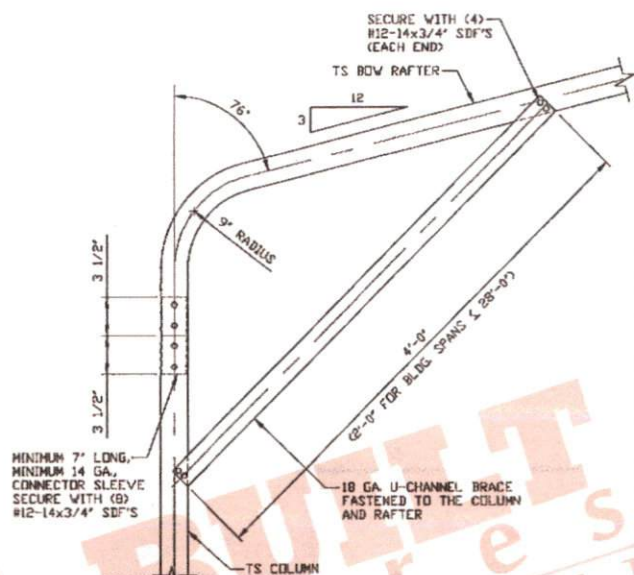

1C

**BOW EAVE RAFTER/CORNER POST CONNECTION DETAIL FOR HEIGHTS ≤ 8'-0"**

SCALE: NTS

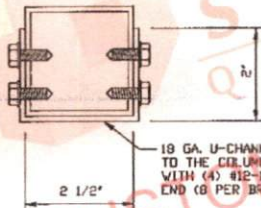

**BRACE SECTION**

SCALE: NTS

MOORE AND ASSOCIATES  
ENGINEERING AND CONSULTING, INC.

DRAWN BY: LT

CHECKED BY: PDH

PROJECT MGR: VSM

CLIENT: PRE-BUILT

PRE-BUILT STRUCTURES  
1330 W JAKE ALEXANDER BLVD.  
SALISBURY, NC 28417  
30'-0" x 16'-0" ENCLOSED STRUCTURE

DATE: 5-6-22

SHT. 8A

SCALE: NTS

DWG. NO: SK-3

JOB NO:  
20217S/22082S

REV: 1

THIS DOCUMENT IS THE PROPERTY OF MOORE AND ASSOCIATES ENGINEERING AND CONSULTING. THE UNAUTHORIZED REPRODUCTION, COPYING, OR OTHERWISE USE OF THIS DOCUMENT IS STRICTLY PROHIBITED AND ANY INFRINGEMENT THEREUPON MAY BE SUBJECT TO LEGAL ACTION.



## BASE RAIL ANCHORAGE OPTIONS

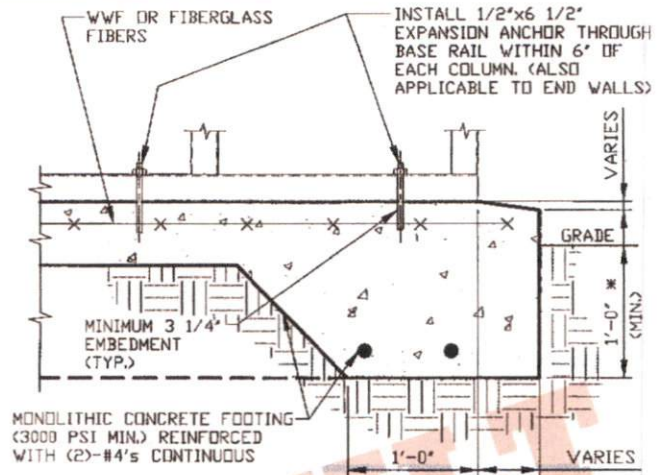
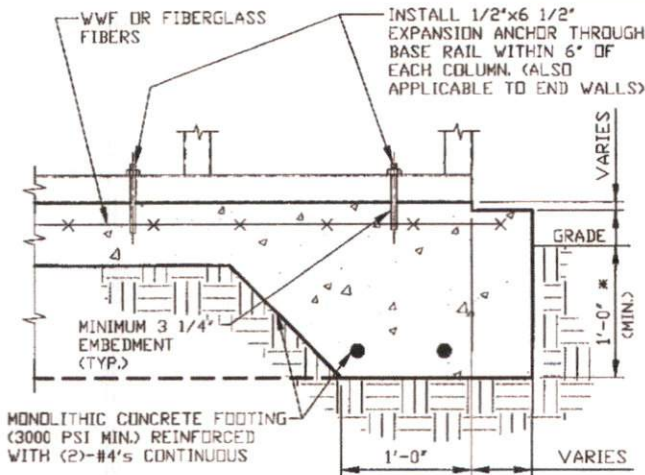

2

### CONCRETE MONOLITHIC SLAB BASE RAIL ANCHORAGE

SCALE: NTS

- MINIMUM ANCHOR EDGE DISTANCE IS 4".
- \* COORDINATE WITH LOCAL CODES/ORD. REGARDING MINIMUM FROST DEPTH REQ.

2A

### CONCRETE SLAB BASE RAIL ANCHORAGE

SCALE: NTS

- MINIMUM ANCHOR EDGE DISTANCE IS 4".
- \* COORDINATE WITH LOCAL CODES/ORD. REGARDING MINIMUM FROST DEPTH REQ.

### GENERAL NOTES

NOTE: CONCRETE MONOLITHIC SLAB DESIGN BASED ON MINIMUM SOIL BEARING CAPACITY OF 1,500 PSF.

#### CONCRETE:

CONCRETE SHALL HAVE A MINIMUM SPECIFIED COMPRESSIVE STRENGTH OF 3,000 PSI AT 28 DAYS.

#### COVER OVER REINFORCING STEEL:

FOR FOUNDATIONS, MINIMUM CONCRETE COVER OVER REINFORCING BARS SHALL BE PER ACI-318.  
3" IN FOUNDATIONS WHERE THE CONCRETE IS CAST AGAINST AND PERMANENTLY IN CONTACT WITH THE EARTH OR EXPOSED TO THE EARTH OR WEATHER, AND 1 1/2" ELSEWHERE.

#### REINFORCING STEEL:

THE TURNDOWN REINFORCING STEEL SHALL BE ASTM A615 GRADE 60. THE SLAB REINFORCEMENT SHALL BE WELDED WIRE FABRIC MEETING ASTM A185 OR FIBERGLASS FIBER REINFORCEMENT.

#### REINFORCEMENT MAY BE BENT IN THE SHOP OR THE FIELD PROVIDED:

1. REINFORCEMENT IS BENT COLD.
2. THE DIAMETER OF THE BEND, MEASURED ON THE INSIDE OF THE BAR, IS NOT LESS THAN SIX-BAR DIAMETERS.
3. REINFORCEMENT PARTIALLY EMBEDDED IN CONCRETE SHALL NOT BE FIELD BENT.

#### HELIX ANCHOR NOTES:

1. FOR VERY DENSE AND/OR CEMENTED SANDS, COARSE GRAVEL AND COBBLES, CALICHE, PRELOADED SILTS AND CLAYS, USE MINIMUM (2) 4" HELICES WITH MINIMUM 30" EMBEDMENT OR SINGLE 6" HELIX WITH MINIMUM 50" EMBEDMENT.
2. FOR CORAL USE MINIMUM (2) 4" HELICES WITH MINIMUM 30" EMBEDMENT OR SINGLE 6" HELIX WITH MINIMUM 50" EMBEDMENT.
3. FOR MEDIUM DENSE COARSE SANDS, SANDY GRAVELS, VERY STIFF SILTS, AND CLAYS USE MINIMUM (2) 4" HELICES WITH MINIMUM 30 INCH EMBEDMENT OR SINGLE 6" HELIX WITH MINIMUM 50" EMBEDMENT.
4. FOR LOOSE TO MEDIUM DENSE SANDS, FIRM TO STIFF CLAYS AND SILTS ALLUVIAL FILL, USE MINIMUM (2) 6" HELICES WITH MINIMUM 50" EMBEDMENT.
5. FOR VERY LOOSE TO MEDIUM DENSE SANDS, FIRM TO STIFFER CLAYS AND SILTS, ALLUVIAL FILL, USE MINIMUM (2) 8" HELICES WITH MINIMUM 60" EMBEDMENT.

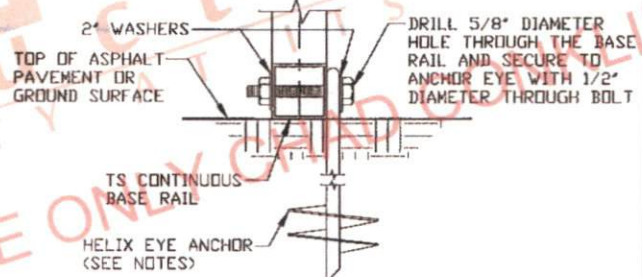

2B

### GROUND BASE HELIX ANCHORAGE

SCALE: NTS

- (CAN BE USED FOR ASPHALT)
- \* COORDINATE WITH LOCAL CODES/ORD. REGARDING MINIMUM FROST DEPTH REQ.

**MOORE AND ASSOCIATES  
ENGINEERING AND CONSULTING, INC.**

DRAWN BY: LT

CHECKED BY: PDH

PROJECT MGR: VSM

CLIENT: PRE-BUILT

PRE-BUILT STRUCTURES  
1330 W JAKE ALEXANDER BLVD.  
SALISBURY, NC 28417  
30'-0" x 16'-0" ENCLOSED STRUCTURE

DATE: 5-6-22

SHT. 9

SCALE: NTS

DWG. NO: SK-3

JOB NO:  
20217S/22082S

REV: 1

THIS DOCUMENT IS THE PROPERTY OF MOORE AND ASSOCIATES ENGINEERING AND CONSULTING. THE UNAUTHORIZED REPRODUCTION, COPYING, OR OTHERWISE USE OF THIS DOCUMENT IS STRICTLY PROHIBITED AND ANY INFRINGEMENT THEREUPON MAY BE SUBJECT TO LEGAL ACTION.

# BOX EAVE RAFTER END WALL AND SIDE WALL FRAMING SECTIONS

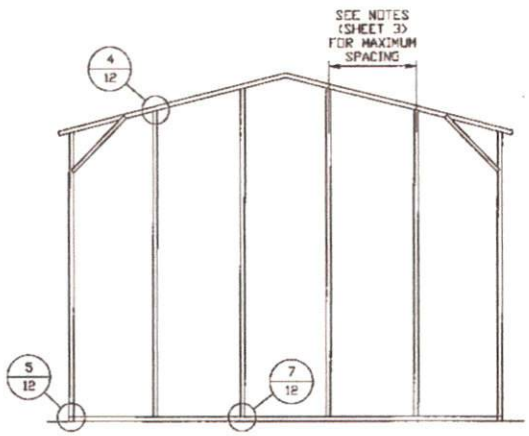

**TYPICAL BOX EAVE RAFTER  
END WALL FRAMING SECTION**

SCALE: NTS

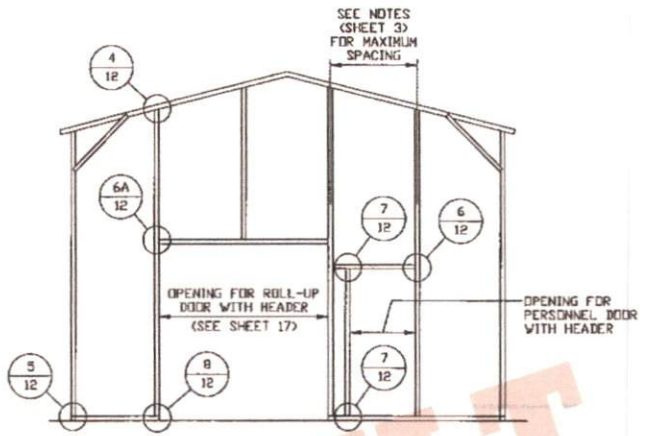

**TYPICAL BOX EAVE RAFTER END  
WALL OPENINGS FRAMING SECTION**

SCALE: NTS

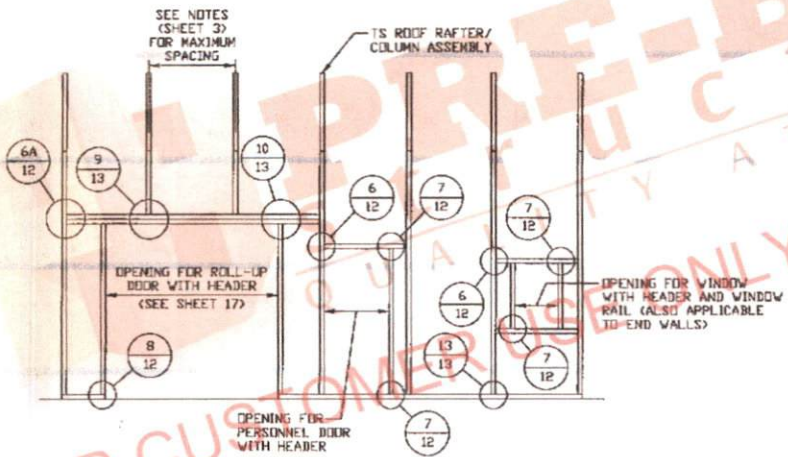

**TYPICAL BOX EAVE RAFTER  
SIDE WALL OPENINGS FRAMING SECTION**

SCALE: NTS

**MOORE AND ASSOCIATES  
ENGINEERING AND CONSULTING, INC.**

**DRAWN BY: LT**

**CHECKED BY: PDH**

**PROJECT MGR: VSM**

**CLIENT: PRE-BUILT**

PRE-BUILT STRUCTURES  
1330 W JAKE ALEXANDER BLVD.  
SALISBURY, NC 28417  
30'-0" x 16'-0" ENCLOSED STRUCTURE

**DATE: 5-6-22**

**SHT. 10**

**SCALE: NTS**

**DWG. NO: SK-3**

**JOB NO:  
202175/220825**

**REV: 1**

THIS DOCUMENT IS THE PROPERTY OF MOORE AND ASSOCIATES ENGINEERING AND CONSULTING. THE UNAUTHORIZED REPRODUCTION, COPYING, OR OTHERWISE USE OF THIS DOCUMENT IS STRICTLY PROHIBITED AND ANY INFRINGEMENT THEREUPON MAY BE SUBJECT TO LEGAL ACTION.



# BOW EAVE RAFTER END WALL AND SIDE WALL FRAMING SECTIONS

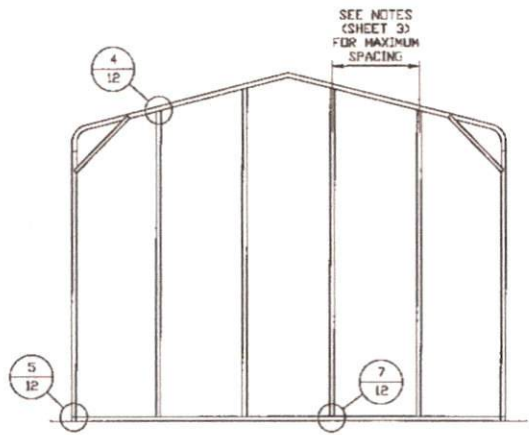

**TYPICAL BOW EAVE RAFTER  
END WALL FRAMING SECTION**  
SCALE: NTS

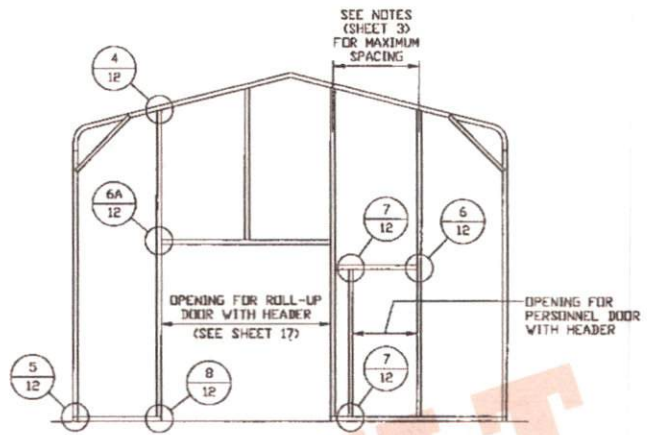

**TYPICAL BOW EAVE RAFTER END  
WALL OPENINGS FRAMING SECTION**  
SCALE: NTS

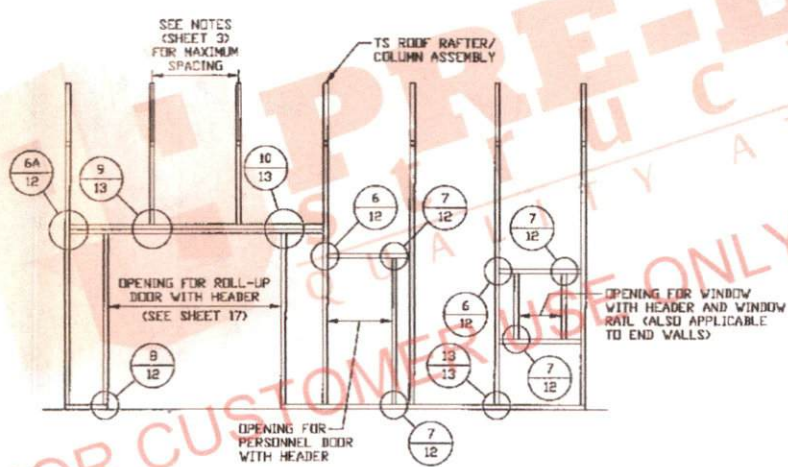

**TYPICAL BOW EAVE RAFTER  
SIDE WALL OPENINGS FRAMING SECTION**  
SCALE: NTS

PRE-BUILT STRUCTURES AT ITS BEST  
 ONLY CHAD CONKLIN

<b>MOORE AND ASSOCIATES ENGINEERING AND CONSULTING, INC.</b>	DRAWN BY: LT	PRE-BUILT STRUCTURES 1330 W JAKE ALEXANDER BLVD. SALISBURY, NC 28417 30'-0" x 16'-0" ENCLOSED STRUCTURE		
	CHECKED BY: PMH			
THIS DOCUMENT IS THE PROPERTY OF MOORE AND ASSOCIATES ENGINEERING AND CONSULTING. THE UNAUTHORIZED REPRODUCTION, COPYING, OR OTHERWISE USE OF THIS DOCUMENT IS STRICTLY PROHIBITED AND ANY INFRINGEMENT THEREUPON MAY BE SUBJECT TO LEGAL ACTION.	PROJECT MGR: WSM	DATE: 5-6-22	SCALE: NTS	JOB NO: 20217S/22092S
	CLIENT: PRE-BUILT	SHT. 11	DWG. NO: SK-3	REV: 1

## CONNECTION DETAILS

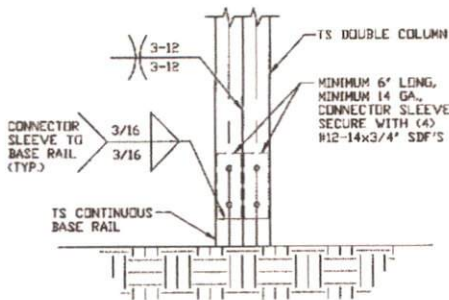

**3 POST/BASE RAIL CONNECTION DETAIL**  
SCALE: NTS

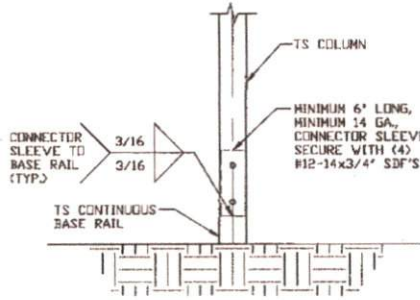

**3A POST/BASE RAIL CONNECTION DETAIL**  
SCALE: NTS

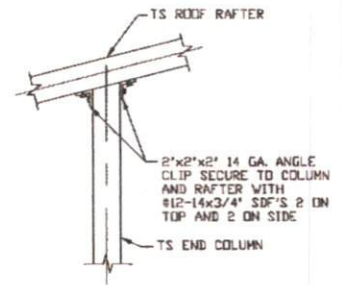

**4 END COLUMN/RAFTER CONNECTION DETAIL**  
SCALE: NTS

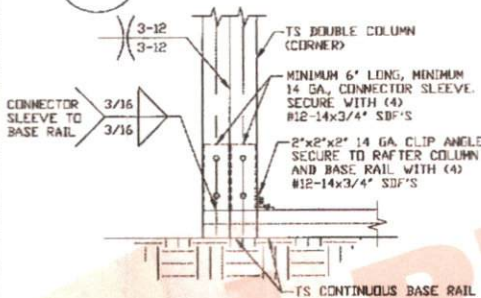

**5 END COLUMN/BASE RAIL CONNECTION DETAIL**  
SCALE: NTS

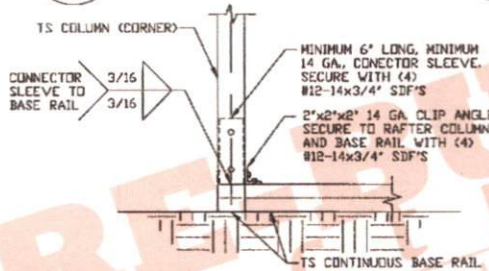

**5A END COLUMN/BASE RAIL CONNECTION DETAIL**  
SCALE: NTS

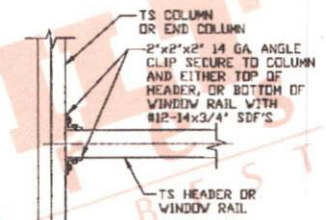

**6 COLUMN OR WINDOW RAIL TO POST CONNECTION DETAIL**  
SCALE: NTS

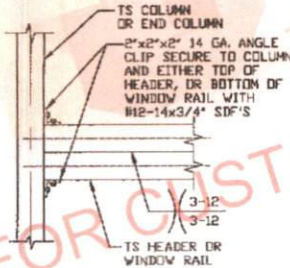

**6A COLUMN OR WINDOW RAIL TO POST CONNECTION DETAIL**  
SCALE: NTS

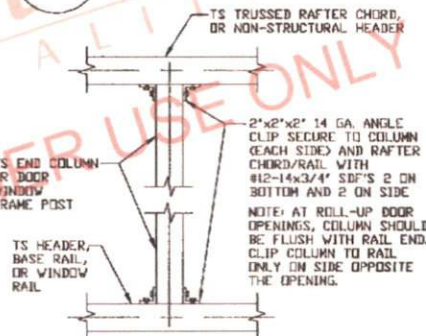

**7 COLUMN TO HEADER, BASE RAIL, OR WINDOW RAIL CONNECTION DETAIL**  
SCALE: NTS

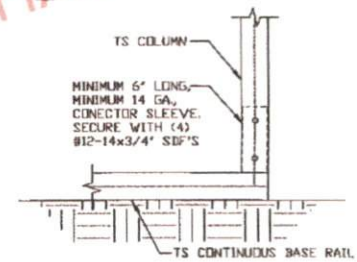

**8 COLUMN/BASE RAIL CONNECTION DETAIL**  
SCALE: NTS

**MOORE AND ASSOCIATES  
ENGINEERING AND CONSULTING, INC.**

DRAWN BY: LT

CHECKED BY: PDH

PROJECT MGR: VSH

CLIENT: PRE-BUILT

PRE-BUILT STRUCTURES  
1330 W JAKE ALEXANDER BLVD.  
SALISBURY, NC 28417  
30'-0" x 16'-0" ENCLOSED STRUCTURE

DATE: 5-6-22

SHT. 12

SCALE: NTS

DWG. NO. SK-3

JOB NO.  
20217S/22082S

REV. 1

THIS DOCUMENT IS THE PROPERTY OF MOORE AND ASSOCIATES ENGINEERING AND CONSULTING. THE UNAUTHORIZED REPRODUCTION, COPYING, OR OTHERWISE USE OF THIS DOCUMENT IS STRICTLY PROHIBITED AND ANY INFRINGEMENT THEREUPON MAY BE SUBJECT TO LEGAL ACTION.



## CONNECTION DETAILS

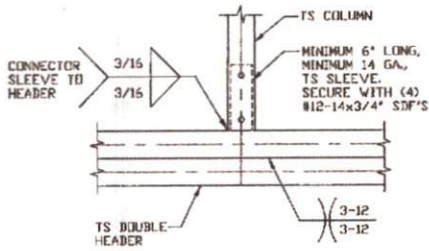

9

**COLUMN/DOUBLE HEADER CONNECTION DETAIL**  
SCALE: NTS

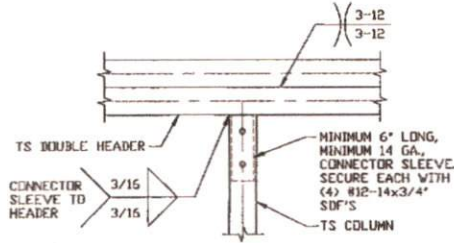

10

**DOUBLE HEADER/COLUMN CONNECTION DETAIL**  
SCALE: NTS

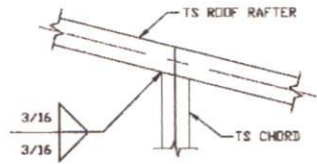

11

**RAFTER TO CHORD CONNECTION DETAIL**  
SCALE: NTS

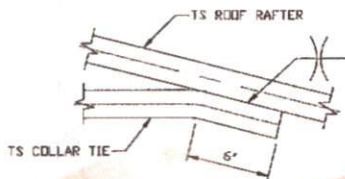

12

**COLLAR TIE CONNECTION DETAIL**  
SCALE: NTS

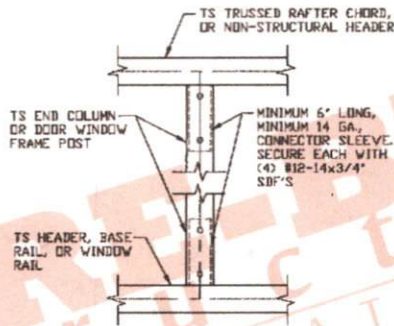

13

**COLUMN TO HEADER OR BASE RAIL CONNECTION DETAIL**  
SCALE: NTS

PRE-BUILT STRUCTURES  
 QUANTITY AT ITS BEST  
 FOR CUSTOMER USE ONLY CHAD CONKLIN

**MOORE AND ASSOCIATES  
ENGINEERING AND CONSULTING, INC.**

DRAWN BY: LT

CHECKED BY: PDH

PROJECT MGR: WSM

CLIENT: PRE-BUILT

PRE-BUILT STRUCTURES  
1330 W JAKE ALEXANDER BLVD.  
SALISBURY, NC 28417  
30'-0" x 16'-0" ENCLOSED STRUCTURE

DATE: 5-6-22

SHT. 13

SCALE: NTS

DWG. NO: SK-3

JOB NO:  
20217S/22092S

REV: 1

THIS DOCUMENT IS THE PROPERTY OF MOORE AND ASSOCIATES ENGINEERING AND CONSULTING. THE UNAUTHORIZED REPRODUCTION, COPYING, OR OTHERWISE USE OF THIS DOCUMENT IS STRICTLY PROHIBITED AND ANY INFRINGEMENT THEREUPON MAY BE SUBJECT TO LEGAL ACTION.

# BOX EAVE RAFTER LEAN-TO OPTIONS

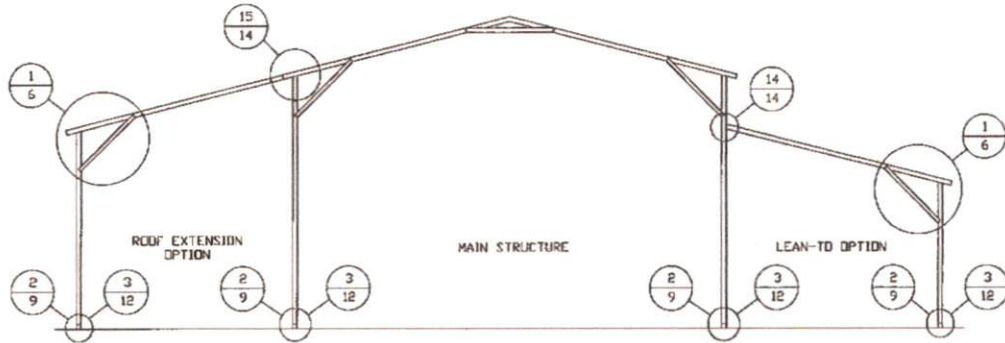

**TYPICAL BOX EAVE RAFTER LEAN-TO OPTIONS FRAMING SECTION (BOTH OPTIONS SHOWN)**

SCALE: NTS

REFERENCE RAFTER COLUMN CONNECTION DETAILS FOR APPROPRIATE COLUMN HEIGHT AND TUBING SPECIFICATIONS UTILIZED IN A LEAN-TO CONFIGURATION.

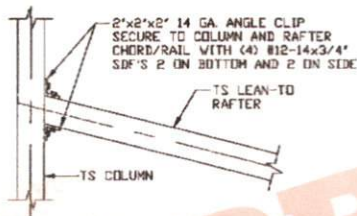

**14 LEAN-TO RAFTER TO RAFTER COLUMN CONNECTION DETAIL FOR RAFTER SPANS  $\leq 12'-0"$**

SCALE: NTS

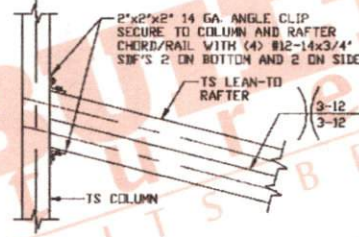

**14A LEAN-TO RAFTER TO RAFTER COLUMN CONNECTION DETAIL FOR RAFTER SPANS  $12'-0" < \text{TO} \leq 16'-0"$**

SCALE: NTS

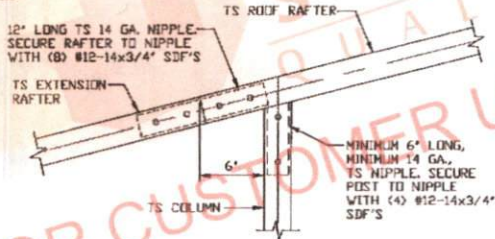

**15 SIDE EXTENSION RAFTER COLUMN DETAIL FOR SPANS  $\leq 12'-0"$**

SCALE: NTS

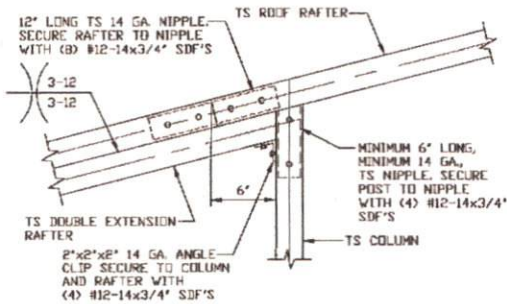

**15A SIDE EXTENSION RAFTER COLUMN DETAIL FOR SPANS  $12'-0" < \text{TO} \leq 16'-0"$**

SCALE: NTS

**MOORE AND ASSOCIATES  
ENGINEERING AND CONSULTING, INC.**

**DRAWN BY: LT**

**CHECKED BY: PDH**

**PROJECT MGR: VSM**

**CLIENT: PRE-BUILT**

PRE-BUILT STRUCTURES  
1330 W JAKE ALEXANDER BLVD.  
SALISBURY, NC 28417  
30'-0" x 16'-0" ENCLOSED STRUCTURE

**DATE: 5-6-22**

**SHT. 14**

**SCALE: NTS**

**DWG. NO: SK-3**

**JOB NO:  
20217S/20202S**

**REV: 1**

THIS DOCUMENT IS THE PROPERTY OF MOORE AND ASSOCIATES ENGINEERING AND CONSULTING. THE UNAUTHORIZED REPRODUCTION, COPYING, OR OTHERWISE USE OF THIS DOCUMENT IS STRICTLY PROHIBITED AND ANY INFRINGEMENT THEREUPON MAY BE SUBJECT TO LEGAL ACTION.



## BOW EAVE RAFTER LEAN-TO OPTIONS

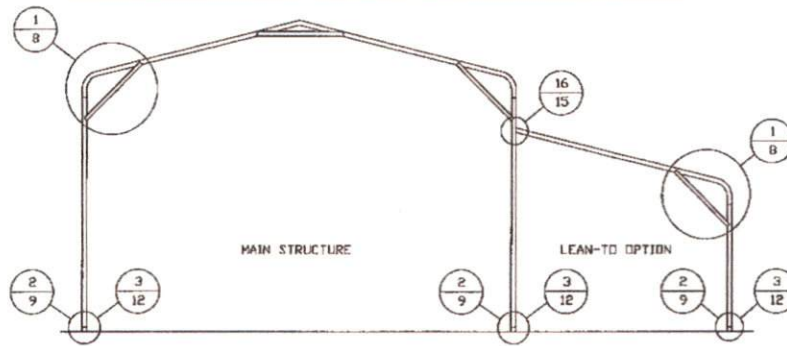

### TYPICAL BOW EAVE RAFTER LEAN-TO OPTIONS FRAMING SECTION

SCALE: NTS  
 REFERENCE RAFTER COLUMN CONNECTION DETAILS FOR APPROPRIATE COLUMN HEIGHT AND TUBING SPECIFICATIONS UTILIZED IN A LEAN-TO CONFIGURATION.

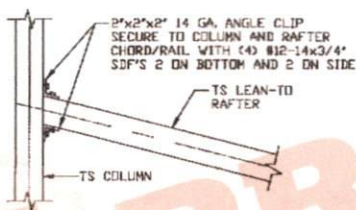

**LEAN-TO RAFTER TO RAFTER COLUMN CONNECTION DETAIL FOR RAFTER SPANS  $\leq 12'-0''$**

SCALE: NTS

16

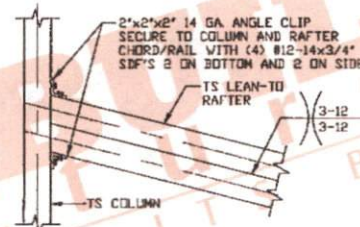

**LEAN-TO RAFTER TO RAFTER COLUMN CONNECTION DETAIL FOR RAFTER SPANS  $12'-0'' < \text{TO} \leq 16'-0''$**

SCALE: NTS

16A

PRE-BUILT STRUCTURES  
 QUALITY CONSTRUCTION BEST  
 FOR CUSTOMER USE ONLY © PRE-BUILT STRUCTURES CONKLIN

**MOORE AND ASSOCIATES  
 ENGINEERING AND CONSULTING, INC.**

DRAWN BY: LT

CHECKED BY: PDH

PROJECT MGR: VSM

CLIENT: PRE-BUILT

PRE-BUILT STRUCTURES  
 1330 W JAKE ALEXANDER BLVD.  
 SALISBURY, NC 28417  
 30'-0" x 16'-0" ENCLOSED STRUCTURE

DATE: 5-6-22

SHT. 15

SCALE: NTS

DWG. NO: SK-3

JOB NO:  
202175/22082S

REV: 1

THIS DOCUMENT IS THE PROPERTY OF MOORE AND ASSOCIATES ENGINEERING AND CONSULTING. THE UNAUTHORIZED REPRODUCTION, COPYING, OR OTHERWISE USE OF THIS DOCUMENT IS STRICTLY PROHIBITED AND ANY INFRINGEMENT THEREUPON MAY BE SUBJECT TO LEGAL ACTION.

## BOX EAVE RAFTER VERTICAL ROOF/SIDING OPTION

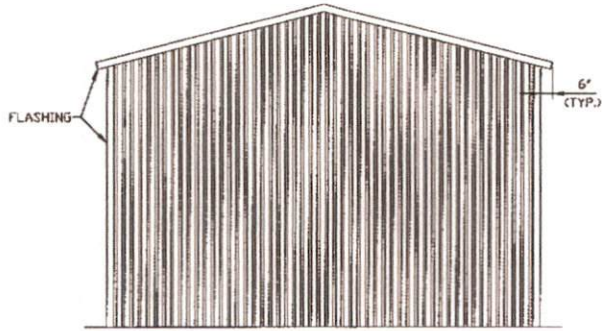

**TYPICAL END ELEVATION  
VERTICAL ROOF/SIDING**

SCALE: NTS

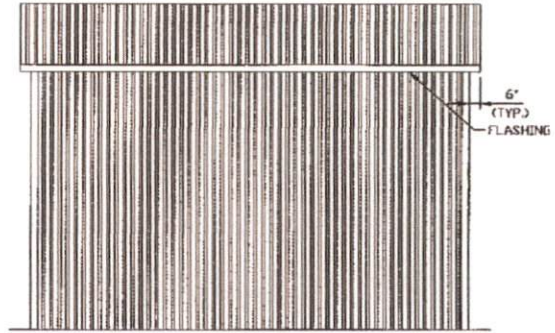

**TYPICAL SIDE ELEVATION  
VERTICAL ROOF/SIDING**

SCALE: NTS

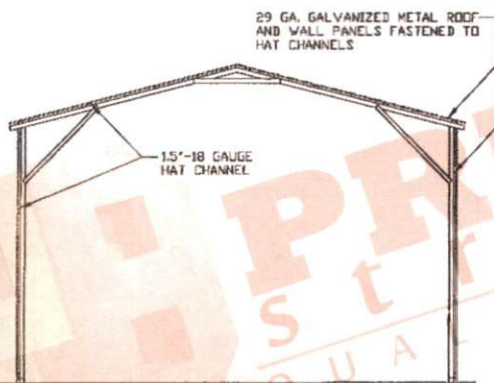

**TYPICAL SECTION VERTICAL  
ROOF/SIDING OPTION**

SCALE: NTS

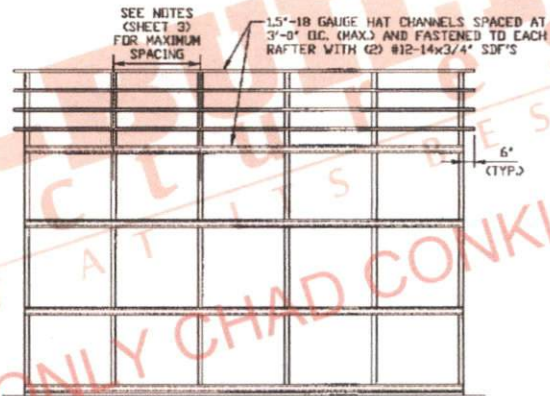

**TYPICAL FRAMING SECTION VERTICAL  
ROOF/SIDING OPTION WITH TS GIRTS**

SCALE: NTS

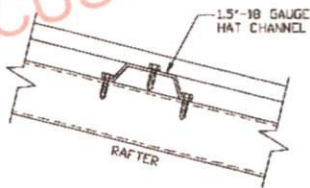

**PANEL ATTACHMENT**

(ALTERNATE FOR VERTICAL ROOF PANELS)

SCALE: NTS

**MOORE AND ASSOCIATES  
ENGINEERING AND CONSULTING, INC.**

DRAWN BY: LT

CHECKED BY: PDH

PROJECT MGR: WSM

CLIENT: PRE-BUILT

PRE-BUILT STRUCTURES  
1330 W JAKE ALEXANDER BLVD.  
SALISBURY, NC 28417  
30'-0" x 16'-0" ENCLOSED STRUCTURE

DATE: 5-6-22

SHT. 16

SCALE: NTS

DWG. NO: SK-3

JOB NO:  
22217S/22082S

REV: 1

THIS DOCUMENT IS THE PROPERTY OF MOORE AND ASSOCIATES ENGINEERING AND CONSULTING. THE UNAUTHORIZED REPRODUCTION, COPYING, OR OTHERWISE USE OF THIS DOCUMENT IS STRICTLY PROHIBITED AND ANY INFRINGEMENT THEREUPON MAY BE SUBJECT TO LEGAL ACTION.



## SIDE WALL HEADER OPTIONS

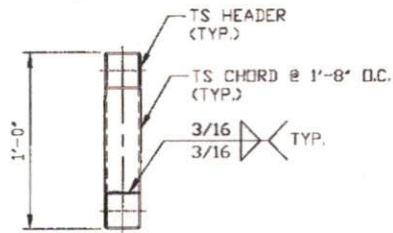

**HEADER DETAIL FOR SIDE WALL  
DOOR OPENINGS**  
**12'-0" < LENGTH ≤ 16'-0"**

SCALE: NTS

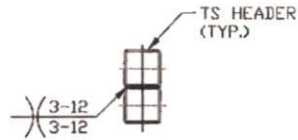

**HEADER DETAIL FOR SIDE WALL  
DOOR OPENINGS ≤ 12'-0"**

SCALE: NTS

## END WALL HEADER OPTIONS

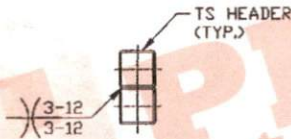

**HEADER DETAIL FOR SIDE WALL  
DOOR OPENINGS**  
**14'-0" < LENGTH ≤ 16'-0"**

SCALE: NTS



**HEADER DETAIL FOR END WALL  
DOOR OPENINGS ≤ 14'-0"**

SCALE: NTS

**PRE-BUILT**  
 STRUCTURES  
 AT ITS BEST  
 CHAD CONKLIN  
 FOR CUSTOMER USE ONLY

**MOORE AND ASSOCIATES  
ENGINEERING AND CONSULTING, INC.**

DRAWN BY: LT

CHECKED BY: PDH

PROJECT MGR: VSM

CLIENT: PRE-BUILT

PRE-BUILT STRUCTURES  
1330 W JAKE ALEXANDER BLVD.  
SALISBURY, NC 28417  
30'-0" x 16'-0" ENCLOSED STRUCTURE

DATE: 5-6-22

SHT. 17

SCALE: NTS

DWG. NO. SK-3

JOB NO.  
20217S/22082S

REV. 1

THIS DOCUMENT IS THE PROPERTY OF MOORE AND ASSOCIATES ENGINEERING AND CONSULTING. THE UNAUTHORIZED REPRODUCTION, COPYING, OR OTHERWISE USE OF THIS DOCUMENT IS STRICTLY PROHIBITED AND ANY INFRINGEMENT THEREUPON MAY BE SUBJECT TO LEGAL ACTION.