

Rear

28'

11'-6"

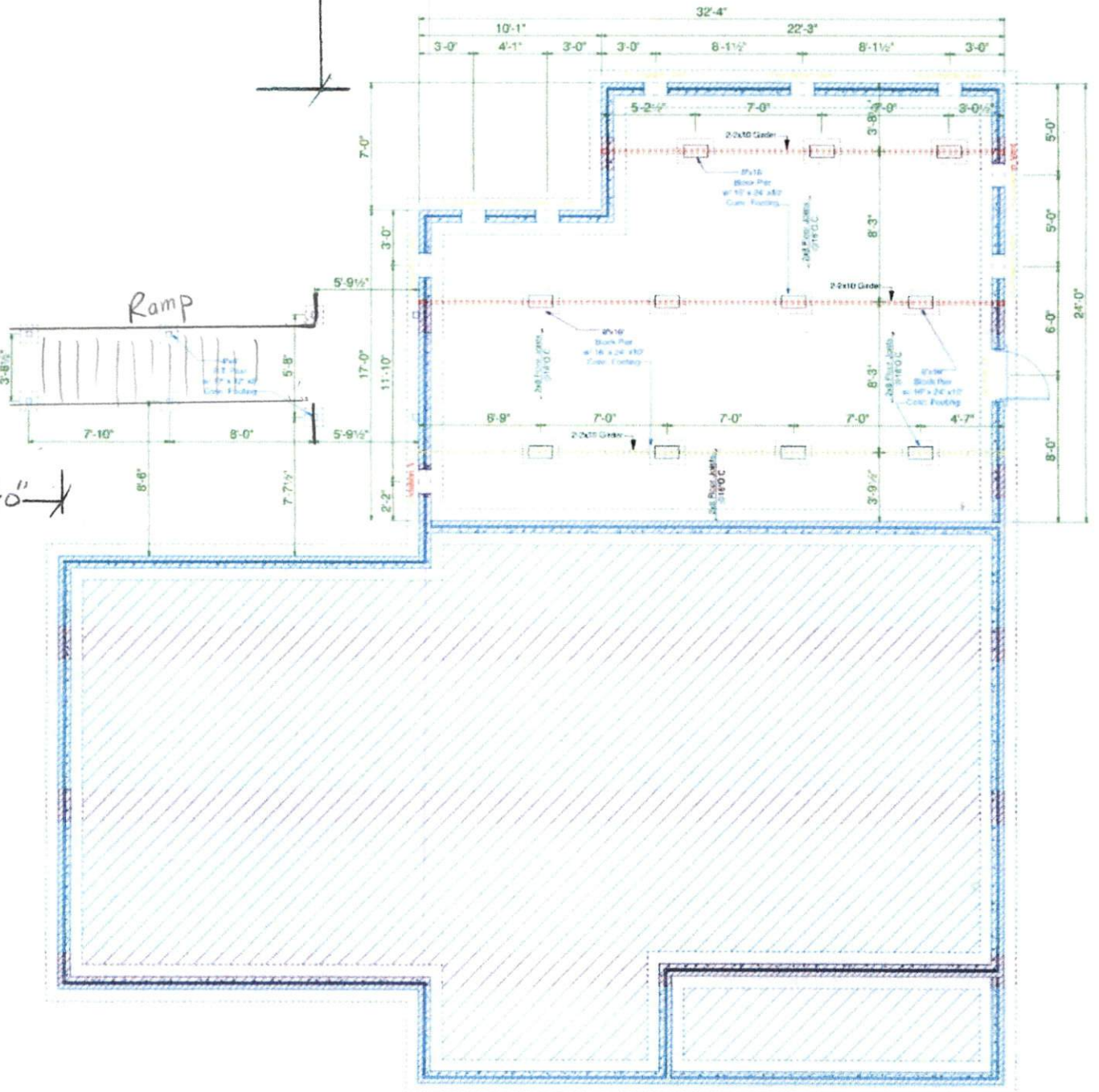

168'

Ramp

12'

30'-0"

Foundation Layout

Crawlspace

FOUNDATION VENT

Existing

655 S.F. / 150 x 4.35 S.F. VENT

Front

107 Person Court
Spring Lake

The information in these documents is intended to be used for informational purposes only. It is not intended to be used as a basis for any legal action. The Designer is not responsible for any errors or omissions in this document. The Designer is not responsible for any consequences that may result from the use of this information. The Designer is not responsible for any consequences that may result from the use of this information. The Designer is not responsible for any consequences that may result from the use of this information.

NOTICE TO CONTRACTOR
 APPROVED
 02/27/2024
 HARNETT COUNTY
 WOOD BRIDGE

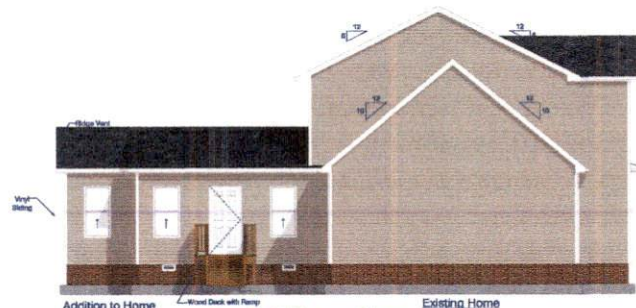

Left Elevation
 Scale: 1/8" = 1'0"

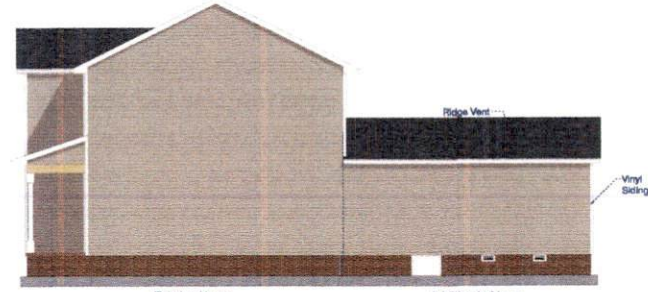

Right Elevation
 Scale: 1/8" = 1'0"



Rear Elevation
 Scale: 1/8" = 1'0"

I DO HEREBY CERTIFY THAT THIS DRAWING OR PLAN AND RELATED SPECIFICATIONS MEET ALL LOCAL REQUIREMENTS AND ARE IN SUBSTANTIAL CONFORMITY WITH BOTH 64H AND VA MINIMUM PROPERTY REQUIREMENTS INCLUDING THE INTERNATIONAL BUILDING CODE COUNCIL (2018 NC BUILDING CODE) ENERGY CONSERVATION STANDARDS OF THE 2018 COUNCIL OF AMERICAN BUILDING OFFICIALS, MODEL ENERGY CODE AND THE REQUIREMENT FOR LEAD-FREE PIPING.

APPROVAL BY	DATE
 FRAZIER DESIGNS MEMBER A I B D AMERICAN INSTITUTE OF BUILDING DESIGN	
Frazier Designs A Residential Design Company (910) 818-9413 www.frazierplans.com	
Project: Sutton Addition 107 Person Ct, Spring Lake, NC 28390 MODEL: FD-632 BUILDER:	
DATE PRINTED: Oct. 2023 DRAWN BY: RTF	
Elevations	
SHEET 1	

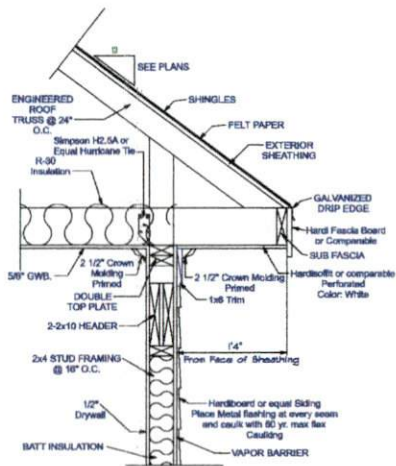

Overhang Detail - Siding

Not to Scale
 ***If Roof is to be Slick Built,
 See Structural Engineers Details
 for Specifications**

NOTE THAT "CORNER" STYLING/ROOF SQUARE
 VENTS MUST BE PROVIDED IN ADDITION TO ONE IN LINE
 OF AREA VENTS INDICATED.

SEE 30 SQ. FT. UNOCCUPIED + BLUAY VENTILATION AREA REQD.

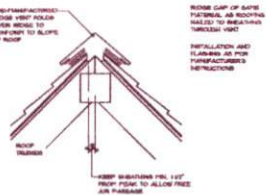

RIDGE VENT

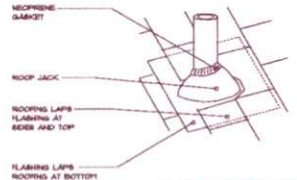

ROOF JACKS AND VENTS

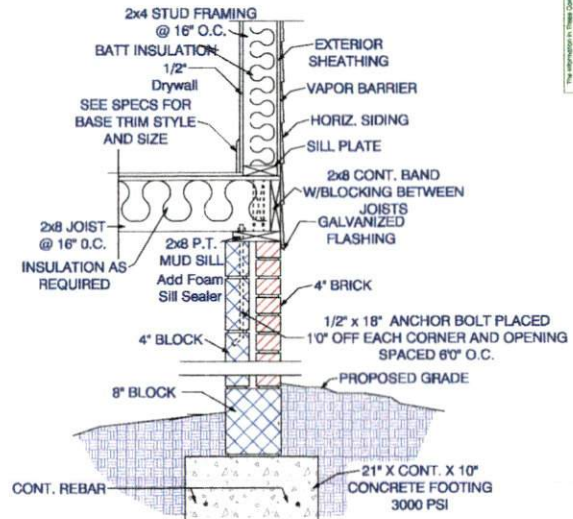

**Exterior Wall Detail
 Siding - 4" Brick/4" Block**

Not to Scale
 Use Grout Stop to ensure
 Full embedding of Anchor bolt.

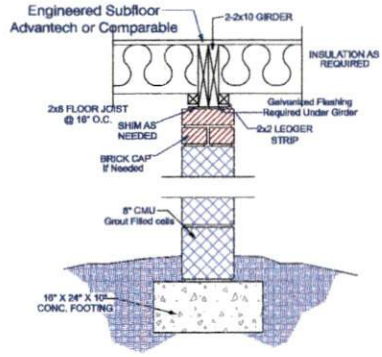

**2-2X10 Girder
 8X16 Pier**

Not to Scale

THE INFORMATION CONTAINED ON THIS DRAWING IS THE PROPERTY OF FRAZIER DESIGNS, INC. AND IS TO BE USED ONLY FOR THE PROJECT AND SITE SPECIFICALLY IDENTIFIED HEREON. ANY REUSE OR MODIFICATION OF THIS DRAWING WITHOUT THE WRITTEN PERMISSION OF FRAZIER DESIGNS, INC. IS STRICTLY PROHIBITED. FRAZIER DESIGNS, INC. IS NOT RESPONSIBLE FOR ANY ERRORS OR OMISSIONS.

APPROVED BY: _____ DATE: _____

FRAZIER DESIGNS
 MEMBER
A I B D
 AMERICAN INSTITUTE OF
 BUILDING DESIGNERS

Frazier Designs
 A Residential Design Company
 (910) 818-9413
 www.frazierplans.com

Project: Sutton Addition
 107 Person Ct, Spring Lake, NC 28390
 MODEL: FD-532
 BUILDER: _____

DATE PRINTED: Oct. 2023
 DRAWN BY: RTF

Details

SHEET
 3

I DO HEREBY CERTIFY THAT THIS DRAWING OR PLAN AND RELATED SPECIFICATIONS MEET ALL LOCAL REQUIREMENTS AND ARE IN SUBSTANTIAL CONFORMITY WITH BOTH IAH AND VA MINIMUM PROPERTY REQUIREMENTS INCLUDING THE INTERNATIONAL BUILDING CODE COUNCIL (2018 NC BUILDING CODE/ENERGY CONSERVATION STANDARDS) OF THE 30th COUNCIL OF AMERICAN BUILDING OFFICIALS/MORE ENERGY CODE AND THE REQUIREMENT FOR LEAD-FREE PIPING.

THIS DRAWING IS THE PROPERTY OF FRAZIER DESIGNS, INC. AND IS TO BE USED ONLY FOR THE PROJECT AND SITE SPECIFICALLY IDENTIFIED HEREON. ANY REUSE OR MODIFICATION OF THIS DRAWING WITHOUT THE WRITTEN CONSENT OF FRAZIER DESIGNS, INC. IS STRICTLY PROHIBITED. FRAZIER DESIGNS, INC. ASSUMES NO LIABILITY FOR ANY ERRORS OR OMISSIONS. THE USER OF THIS DRAWING SHALL BE RESPONSIBLE FOR OBTAINING ALL NECESSARY PERMITS AND FOR VERIFYING THE ACCURACY OF ALL INFORMATION PROVIDED. FRAZIER DESIGNS, INC. IS NOT A LICENSED PROFESSIONAL ENGINEER OR ARCHITECT IN THE STATE OF NORTH CAROLINA. FRAZIER DESIGNS, INC. IS AN EQUAL OPPORTUNITY EMPLOYER. FRAZIER DESIGNS, INC. IS AN AFFIRMATIVE ACTION EMPLOYER. FRAZIER DESIGNS, INC. IS AN EQUAL OPPORTUNITY EMPLOYER. FRAZIER DESIGNS, INC. IS AN AFFIRMATIVE ACTION EMPLOYER.

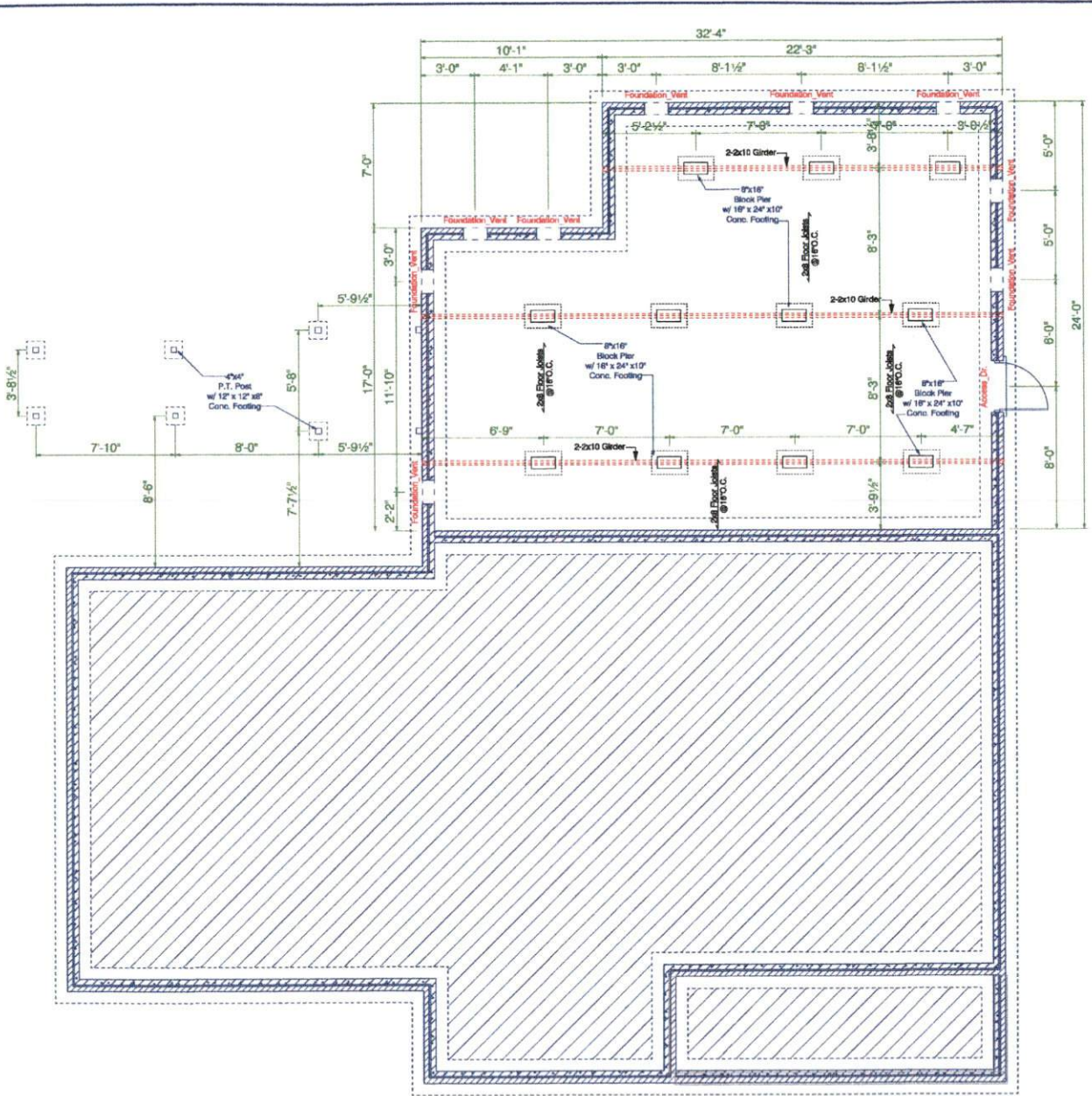

Foundation Layout
Crawspace
 Scale: 1/4" = 1'0"
 Existing

FOUNDATION VENTILATION:
 653 S.F. / 150 = 4.35 S.F. VENTILATION REQ'D

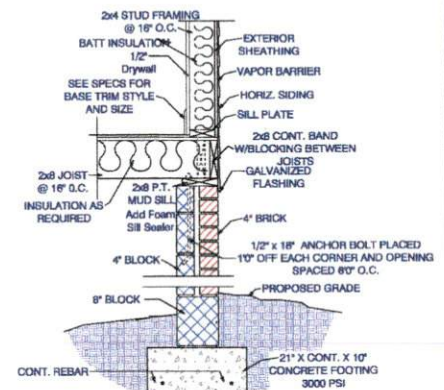

Exterior Wall Detail
Siding - 4" Brick/4" Block
 Not to Scale
 Use Grout Stop to ensure Full embedding of Anchor bolt.

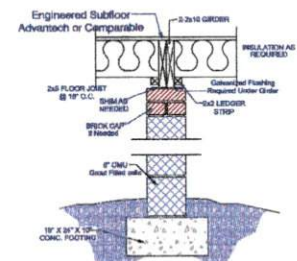

2-2X10 Girder
8X16 Pier
 Not to Scale

I DO HEREBY CERTIFY THAT THIS DRAWING OR PLAN AND RELATED SPECIFICATIONS MEET ALL LOCAL REQUIREMENTS AND ARE IN SUBSTANTIAL CONFORMITY WITH BOTH BAH AND VA MINIMUM PROPERTY REQUIREMENTS INCLUDING THE INTERNATIONAL BUILDING CODE COUNCIL 2018 NC BUILDING CODE/ENERGY CONSERVATION STANDARDS OF THE 2018 COUNCIL OF AMERICAN BUILDING OFFICIALS, MODEL ENERGY CODE AND THE REQUIREMENT FOR LEAD-FREE PIPING.

APPROVED BY	DATE



Frazier Designs
 A Residential Design Company
 (910) 818-9413
 www.frazierplans.com

Project: Sutton Addition
 107 Person Ct, Spring Lake, NC 28390
 MODEL: FD-532
 BUILDER:

DWG PRINTED:
 Oct. 2025
 DRAWN BY:
 RTT

Crawspace
 Layout

SHEET
4

