



First Job
 8722 STENHART RD
 WENONA, NC

WALLACE CREECH
 & COMPANY, INC.
 381 ZACK'S MILL RD.
 BENSON, NC 27504
 919/250-9988

Job 3659725	Truss A01	Truss Type Attic	Qty 21	Ply 1	Wallace Creech / Foust Job
BMC Components					Job Reference (optional)

8.630 s Jan 12 2023 MiTek Industries, Inc. Thu Aug 31 14:16:13 2023 Page 1
 ID:2uHsT1... UOdTuyfKV0g78yditG-79yQch31YmEassn.Jo_DtMHJ8KGAWnAsbx6G?VyiJmG

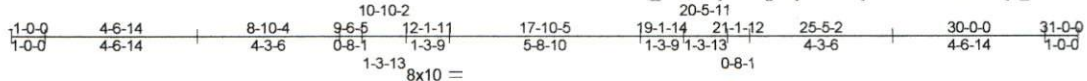

Scale = 1:69.1

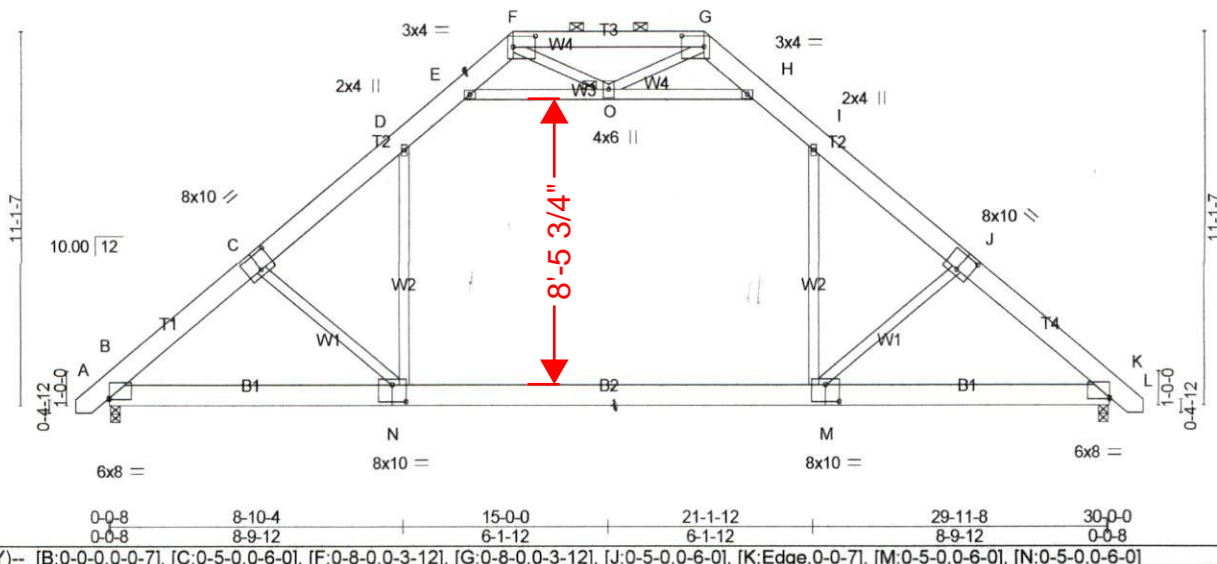

Plate Offsets (X, Y)-- [B:0-0-0,0-0-7], [C:0-5-0,0-6-0], [F:0-8-0,0-3-12], [G:0-8-0,0-3-12], [J:0-5-0,0-6-0], [K:Edge,0-0-7], [M:0-5-0,0-6-0], [N:0-5-0,0-6-0]

LOADING (psf)	SPACING-	CSI.	DEFL.	PLATES	GRIP
TCLL 20.0	2-0-0	TC 0.23	in (loc) l/def L/d	MT20	244/190
TCDL 10.0	Plate Grip DOL 1.00	BC 0.53	Vert(LL) -0.31 M-N >999 240		
BCLL 0.0 *	Lumber DOL 1.15	WB 0.54	Vert(CT) -0.44 M-N >810 180		
BCDL 10.0	Rep Stress Incr YES	Matrix-MS	Horz(CT) 0.03 K n/a n/a		
	Code IRC2015/TPI2014		Attic -0.25 M-N 613 360		
				Weight: 272 lb	FT = 20%

LUMBER-	BRACING-
TOP CHORD 2x8 SP DSS *Except* T3: 2x6 SP No.2	TOP CHORD Structural wood sheathing directly applied or 6-0-0 oc purlins, except 2-0-0 oc purlins (6-0-0 max.): F-G.
BOT CHORD 2x8 SP DSS	BOT CHORD Rigid ceiling directly applied or 10-0-0 oc bracing.
WEBS 2x4 SP No.2	JOINTS 1 Brace at Jt(s): O

MiTek recommends that Stabilizers and required cross bracing be installed during truss erection, in accordance with Stabilizer Installation guide.

REACTIONS. (lb/size) B=1373/0-3-8 (min. 0-1-10), K=1373/0-3-8 (min. 0-1-10)
 Max Horz B=-211(LC 8)
 Max Grav B=1605(LC 2), K=1605(LC 2)

FORCES. (lb) - Max. Comp./Max. Ten. - All forces 250 (lb) or less except when shown.
 TOP CHORD B-C=-2257/17, C-D=-2095/35, D-E=-1354/114, E-F=-301/168, G-H=-301/168,
 H-I=-1354/114, I-J=-2095/35, J-K=-2257/17
 BOT CHORD B-N=0/1749, M-N=0/1484, K-M=0/1631
 WEBS C-N=-333/209, D-N=0/1000, I-M=0/1000, E-O=-1758/66, H-O=-1758/66, J-M=-333/210

- NOTES-**
- 1) Unbalanced roof live loads have been considered for this design.
 - 2) Wind: ASCE 7-10; Vult=115mph Vasd=91mph; TCDL=6.0psf; BCDL=6.0psf; h=30ft; Cat. II; Exp B; Enclosed; MWFRS (envelope) gable end zone and C-C Exterior(2) zone; cantilever left and right exposed; end vertical left and right exposed; C-C for members and forces & MWFRS for reactions shown; Lumber DOL=1.60 plate grip DOL=1.33
 - 3) Provide adequate drainage to prevent water ponding.
 - 4) This truss has been designed for a 10.0 psf bottom chord live load nonconcurrent with any other live loads.
 - 5) * This truss has been designed for a live load of 20.0psf on the bottom chord in all areas where a rectangle 3-6-0 tall by 2-0-0 wide will fit between the bottom chord and any other members.
 - 6) Ceiling dead load (5.0 psf) on member(s). D-E, H-I, E-O, H-O
 - 7) Bottom chord live load (40.0 psf) and additional bottom chord dead load (5.0 psf) applied only to room. M-N
 - 8) This truss is designed in accordance with the 2015 International Residential Code sections R502.11.1 and R802.10.2 and referenced standard ANSI/TPI 1.
 - 9) Graphical purlin representation does not depict the size or the orientation of the purlin along the top and/or bottom chord.
 - 10) Attic room checked for L/360 deflection.

LOAD CASE(S) Standard

1-21155
372 Stewart Rd
Dunn
Scope:

- ① Remove any & all fire damaged material including; sheetrock, insulation, garage doors, walk doors, upstairs windows (2), framing & sheathing, vinyl siding, roof trusses w/ bonus room framing and roof shingles. New electrical wiring from subpanel.
- ② Repair framing in Rt rear of Bldg. Replace trusses, decking and shingles along w/ second floor bonus room (2 footers) framing. Install underlayment in Bonus Room.
- ③ Replace exterior treated wood staircase.
- ④ Install new vinyl framing & siding, new walk doors (3) and new Garage doors w/ openers (2). Install new gutters. Install (2) new vinyl windows.
- ⑤ Install new electrical system w/ fixtures.
- ⑥ Insulate to code
- ⑦ Hang & finish Sheetrock in garage and bonus room. None in storage room.
- ⑧ No HVAC or plumbing.
- ⑨ No well, Septic tank, or landscaping.
- ⑩ Install trim, plank flooring in Bonus, and paint interior.