

**NOTE:**

THIS STRUCTURE IS IN COMPLIANCE WITH THE 2009 & 2012 INTERNATIONAL BUILDING CODES AND INTERNATIONAL RESIDENTIAL CODES. LOADS ARE IN ACCORDANCE WITH ASCE/SEI 7-05 and 7-10.

WIND SPEED (3 SECOND WIND GUST)		120 MPH	130 MPH
IMPORTANCE FACTOR	WIND	0.77	0.77
	SNOW	0.8	0.8
	SEISMIC	1.0	1.0
BUILDING CATEGORY		I	I
EXPOSURE		C	C
INTERNAL PRESSURE COEFFICIENT		±0.55	±0.55
COMPONENT AND CLADDING PRESSURE	WALLS	+32.2/-40.5 PSF	+37.8/-47.5 PSF
	ROOF	+21.8/-65.4 PSF	+25.6/-76.8 PSF
STRUCTURE TYPE		ENCLOSED or OPEN	ENCLOSED or OPEN
GROUND SNOW LOAD		20 PSF	30 / 40 / 50 PSF
SEISMIC DESIGN CATEGORY		D2	D2

**A-FRAME CARPORT DIMENSIONS**  
(SEE TABLE 1)

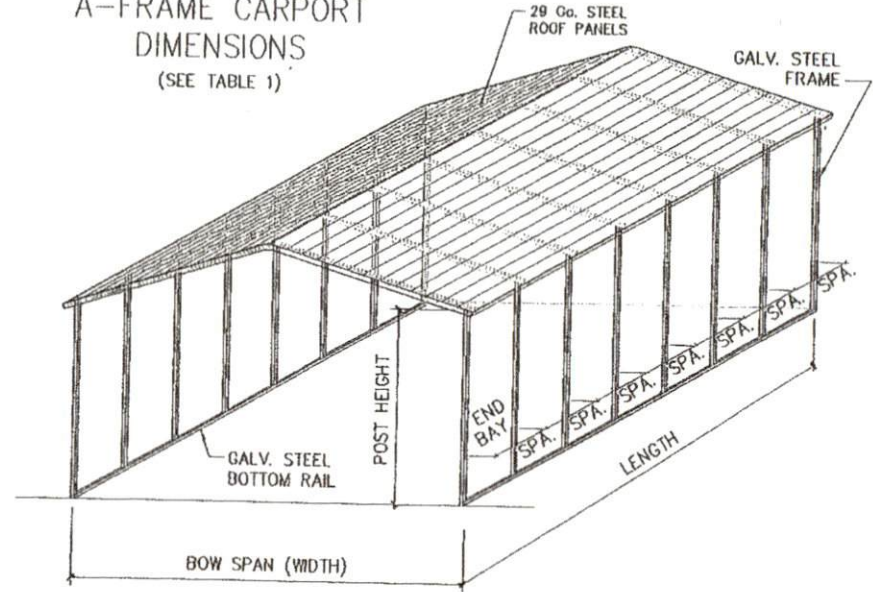

- NOTES:**
- ALL STEEL TUBING SHALL HAVE A MINIMUM YIELD STRENGTH (Fy) OF 65 KSI OR BETTER.
  - ALL FASTENERS ARE CASE HARDENED STEEL HEX SELF-TAPPING SCREWS, 1/4"-14 FOR FRAMING, #12-14 FOR TOP AND TRIM. ROOF DECK SCREWS SHALL HAVE RUBBER WASHERS.
  - FASTEN METAL ROOF AND SIDE PANELS WITH SELF DRILLING FASTENERS AT 8" O.C. MAX.
  - ALL FIELD CONNECTIONS SHALL BE 3/4"x1" SELF DRILLING SCREWS, UNLESS NOTED OTHERWISE.
  - ALL SHOP CONNECTIONS SHALL BE WELDED.
  - THE OWNER IS RESPONSIBLE FOR COMPLYING WITH LOCAL BUILDING CODE REQUIREMENTS.

METAL ACCESSORIES FOR USE IN EXTERIOR WALL CONSTRUCTION AND NOT DIRECTLY EXPOSED TO THE WEATHER SHALL BE GALVANIZED IN ACCORDANCE WITH ASTM A 153, CLASS B-2. METAL PLATE CONNECTORS, SCREWS, BOLTS, AND NAILS EXPOSED TO THE WEATHER SHALL BE STAINLESS STEEL OR HOT DIPPED GALVANIZED.

**TABLE 1**

**FRAME SPACING BASED ON WIND SPEED AND SNOW LOAD**

BOW SPAN	POST HEIGHT	120 / 20		130 / 30		130 / 40		130 / 50			
		TS 2 1/2"x2 1/2"		TS 2 1/2"x2 1/2"		TS 2 1/2"x2 1/2"		TS 2 1/2"x2 1/2"			
		GAGE	SPACING	GAGE	SPACING	GAGE	SPACING	GAGE	SPACING		
12'	8'-0"	14	5'-0"	14	4'-6"	14	4'-0"	14	3'-6"		
	12'-0"	12		12		12					
16'	8'-0"	14		14		14		12		12	12
	12'-0"	12		12		12					
18'	8'-0"	14		14		14		12		12	12
	12'-0"	12		12		12					
20'	8'-0"	14	14	14	12	12	12				
	12'-0"	12	12	12							
22'	8'-0"	12	14	14	12	12	12				
	12'-0"		12	12							
24'	8'-0"	12	14	14	12	12	12				
	12'-0"		4'-3"*	12				4'-0"	3'-6"	3'-0"	

NOTE: CORNER BRACE REQUIRED FOR ALL 10' & 12' POSTS AND FOR ALL 20'-24' SPANS \* OR TS 2 1/2 x 2 1/2 12 Ga. @ 4'-6" MAY BE USED

TS 2 1/2 x 2 1/2 - 14 GAGE STEEL TUBING MAY BE SUBSTITUTED FOR TS 2 1/2 x 2 1/2 - 12 GAGE STEEL TUBING OR VICE VERSA. THE ASSOCIATED CONNECTION MATERIALS AND BRACING MUST BE ADJUSTED ACCORDINGLY TO ACCOMMODATE THE CHANGE IN SIZE.

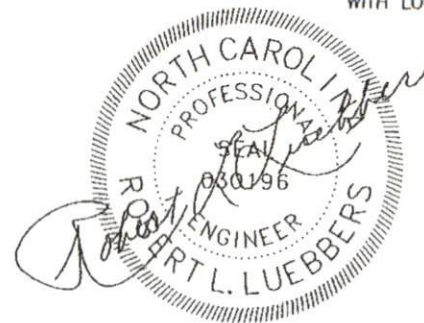

**NEWMART BUILDERS**  
**A-FRAME CARPORTS**

850 LOCUST STREET  
SOUTH HILL, VA 23970  
PHONE (434) 447-2693  
TOLL FREE 1-800-547-8480  
FAX (434) 447-2694

\*PROVIDE CORNER BRACE FOR 10' TO 12' POSTS.  
 \*\*PROVIDE CORNER BRACE AND TOP STRUT FOR 20' TO 24' WIDTHS.

# A-FRAME CARPORT

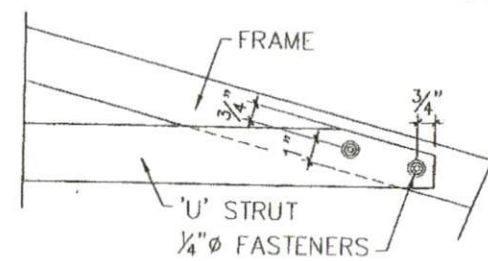
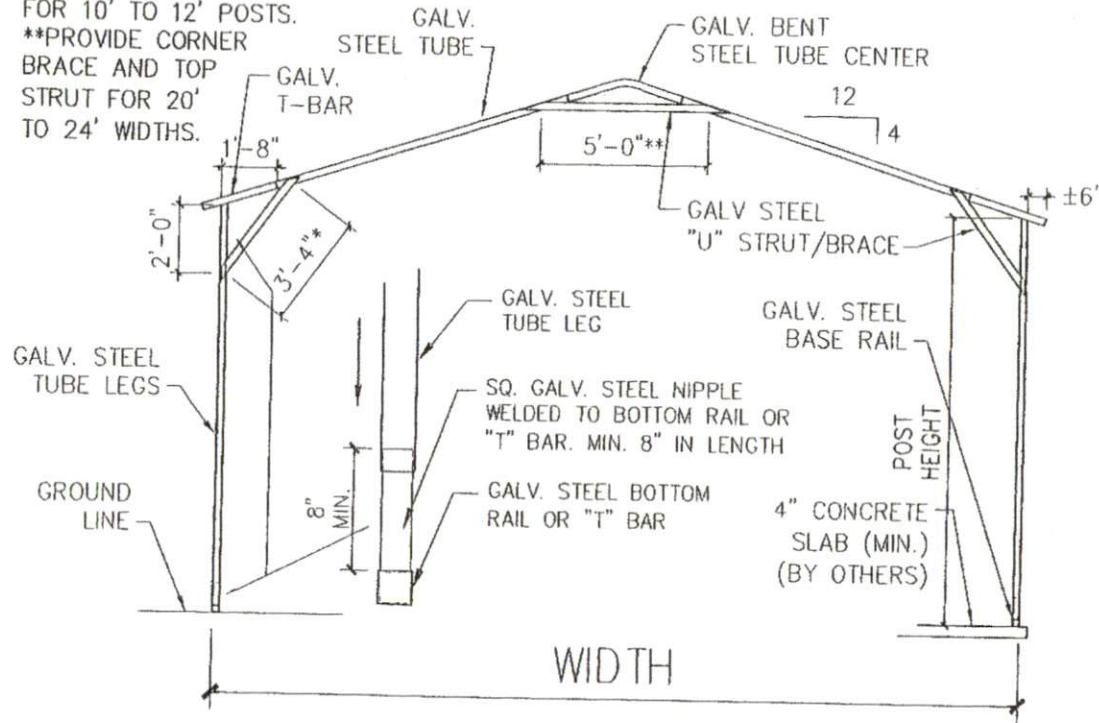

STRUT OR BRACE CONNECTION

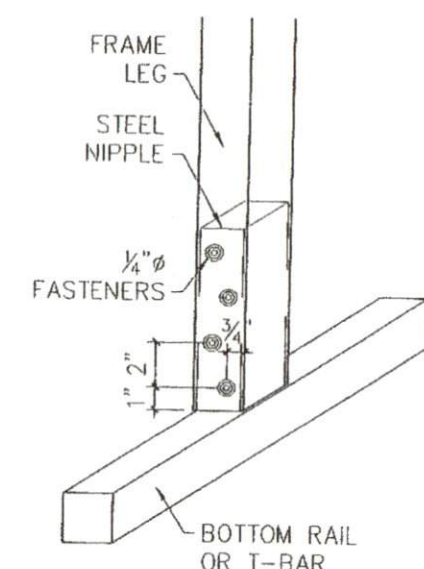

FRAME CONNECTION

GROUND ANCHOR DETAIL

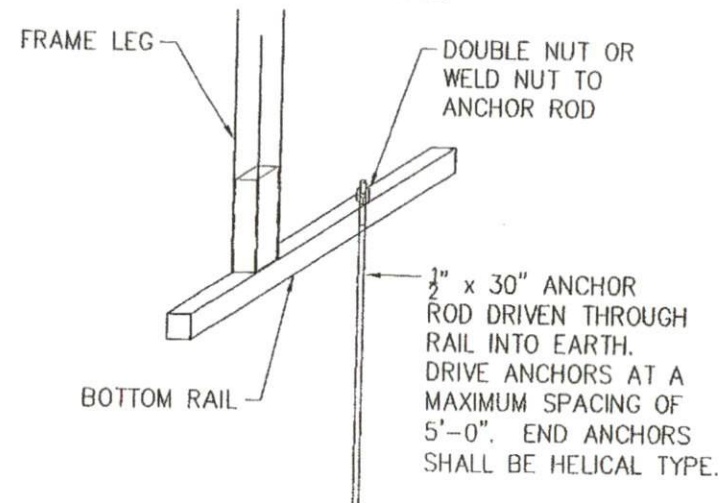

HELICAL ANCHOR DETAIL

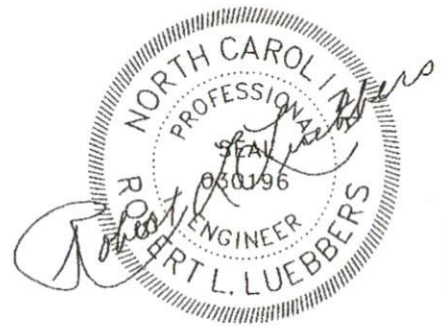
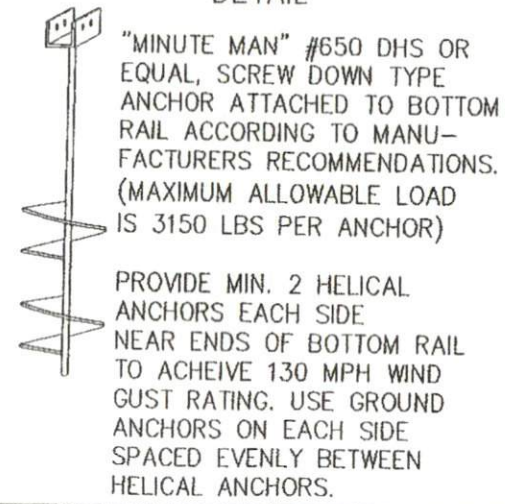

DRILL  $\frac{5}{8}$ " HOLE THROUGH THE  
BASE RAIL AND SECURE TO  
ANCHOR EYE WITH  $\frac{1}{2}$ " DIAMETER  
THROUGH BOLT

GALV. STEEL  
BASE RAIL

2" WASHERS

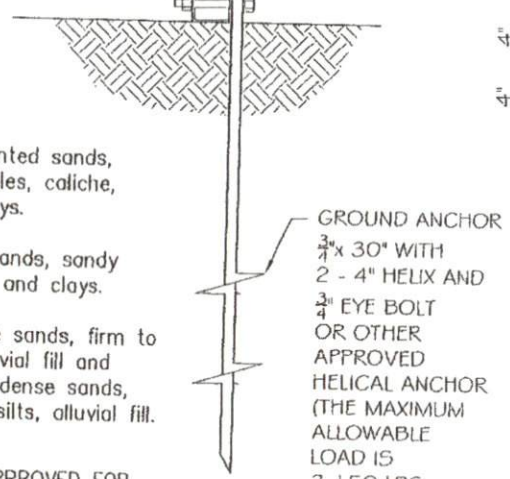

GROUND ANCHOR  
 $\frac{3}{4}$ " x 30" WITH  
2 - 4" HELIX AND  
 $\frac{3}{4}$ " EYE BOLT  
OR OTHER  
APPROVED  
HELICAL ANCHOR  
(THE MAXIMUM  
ALLOWABLE  
LOAD IS  
3,150 LBS  
PER ANCHOR)

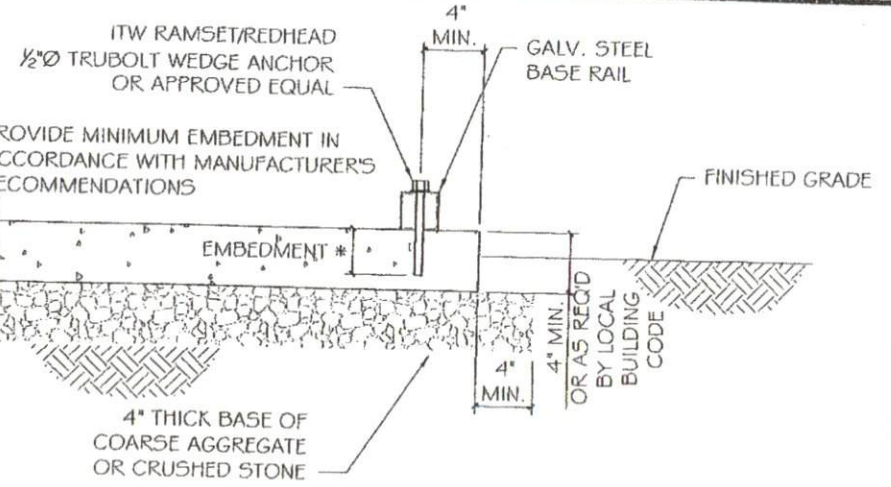

2  
3

CONCRETE BASE RAIL ANCHORAGE

NOTES:

LIGHT GAGE METAL FRAME CARPORTS ARE VERY LIGHTWEIGHT AND FLEXIBLE STRUCTURES. THE BOTTOM RAIL IS USUALLY PLACED EITHER DIRECTLY ON LEVEL GROUND AND SECURED WITH GROUND ANCHORS, OR IS PLACED ON A 4" CONCRETE SLAB OVER A 4" LAYER OF STONE AND SECURED TO THE SLAB WITH  $\frac{1}{2}$ "  $\varnothing$  ANCHOR BOLTS. EXTENDING THE FOUNDATION TO FROST DEPTH TO PREVENT HEAVING IS GENERALLY NOT REQUIRED. HOWEVER, THE OWNER IS RESPONSIBLE FOR COMPLYING WITH THE REQUIREMENTS OF THE LOCAL BUILDING CODE WHICH MAY BE MORE RESTRICTIVE.

CONCRETE SHALL HAVE A MINIMUM SPECIFIED COMPRESSIVE STRENGTH (F'c) OF 2500 PSI AT 28 DAYS.

SOIL CLASSIFICATIONS \*

SOIL CLASS	SOIL DESCRIPTION
2	Very dense &/or cemented sands, coarse gravel and cobbles, caliche, preloaded silts, and clays.
3	Medium dense coarse sands, sandy gravels, very stiff silts, and clays.
4	Loose to medium dense sands, firm to stiff clays and silts alluvial fill and VERY loose to medium dense sands, firm to stiff clays and silts, alluvial fill.

THE HELICAL ANCHOR SHALL BE APPROVED FOR USE IN SOIL CLASSIFICATIONS 2, 3, AND 4.

\* Taken from HUD "Standard for Installation of Mobile Homes"

1  
3

SOIL BASE RAIL ANCHOR DETAIL

NOTE: IF THE DISTANCE BETWEEN HELICAL ANCHORS EXCEEDS 25', PROVIDE AN ADDITIONAL HELICAL ANCHOR MIDWAY BETWEEN.

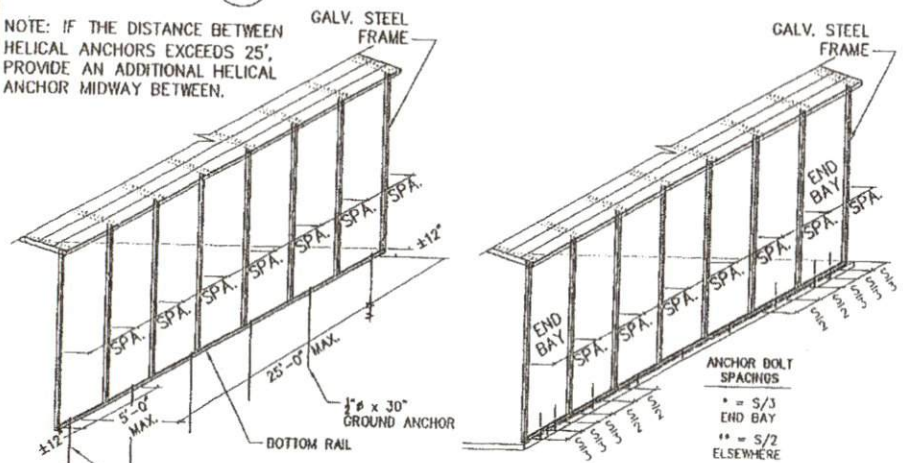

HELICAL GROUND ANCHORS

ANCHOR BOLTS

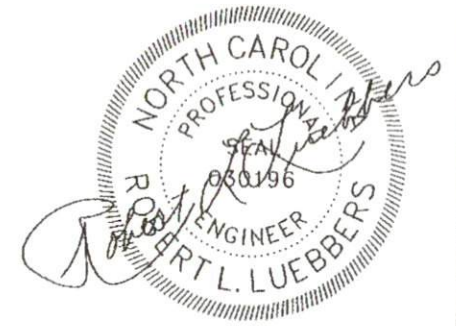

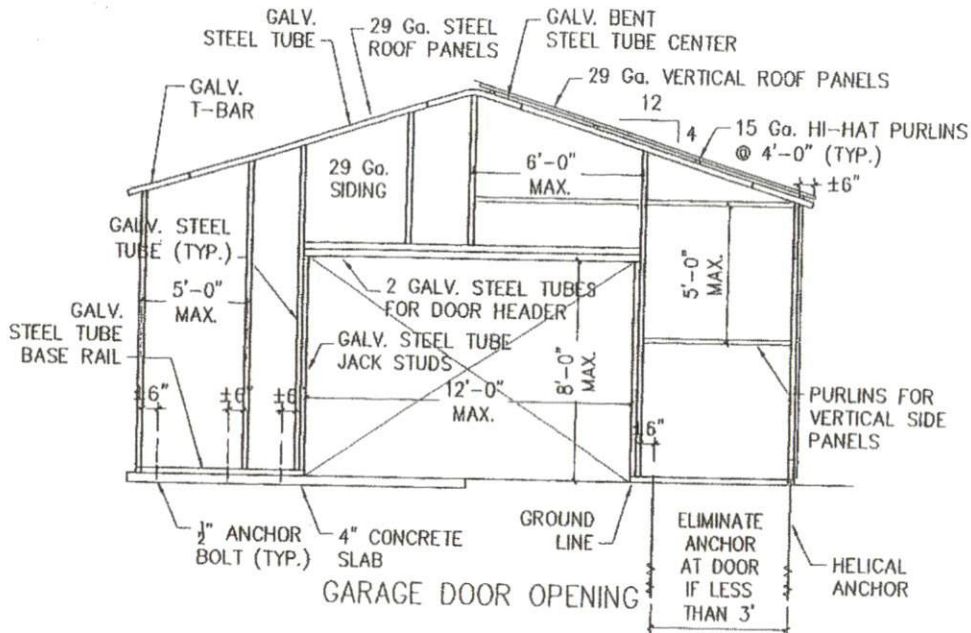

NOTE:  
 EXTERIOR WINDOWS AND GLASS DOORS SHALL BE TESTED BY AN APPROVED INDEPENDENT TESTING LABORATORY AND BEAR AN AAMA OR WDMA OR OTHER APPROVED LABEL IDENTIFYING THE MANUFACTURER, PERFORMANCE CHARACTERISTICS AND APPROVED PRODUCT EVALUATION ENTITY TO INDICATE COMPLIANCE WITH THE REQUIREMENTS OF THE FOLLOWING SPECIFICATION:

ANSI/AAMA/NWDA 101/IS2 2/97  
 THE CONSTRUCTION SHALL BE TESTED IN ACCORDANCE WITH ASTM E 330, STANDARD TEST METHODS FOR STRUCTURAL PERFORMANCE FOR EXTERIOR WINDOWS, CURTAIN WALLS, AND DOORS BY UNIFORM STATIC AIR PRESSURE.

NOTE:  
 ALL WINDOWS AND DOORS SHALL HAVE A MINIMUM DESIGN PRESSURE RATING OF  $\pm 35$  PSF.

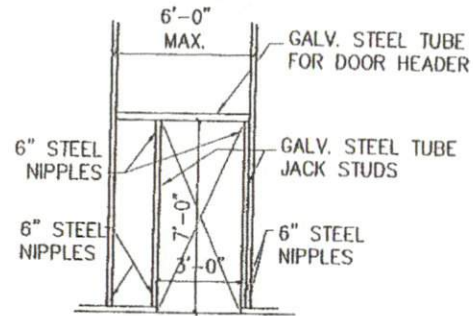

STANDARD DOOR OPENING

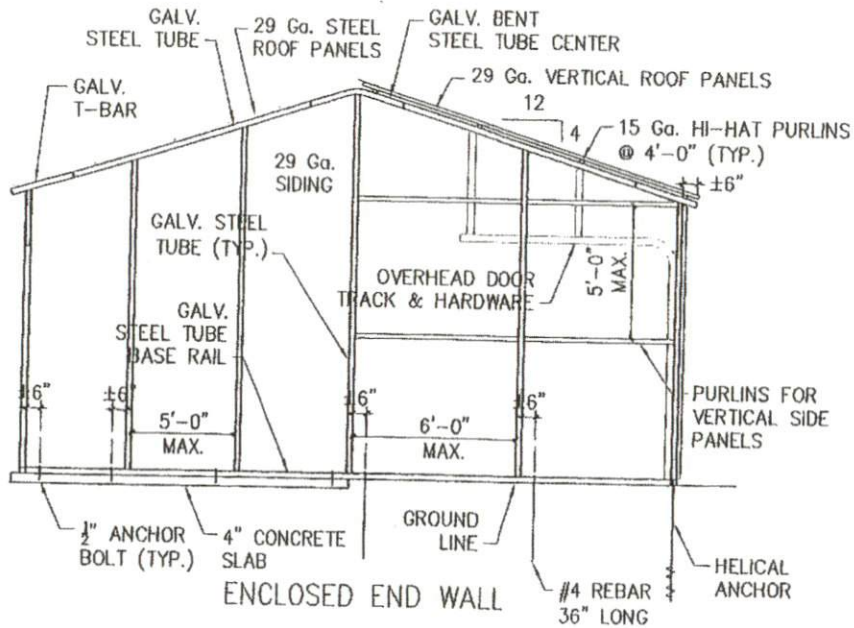

CARPORT WIDTH	MAX. DOOR WIDTH
12'	8'
18'	10'
20'	12'
22'	12'
24'	12'

MAX. DOOR WIDTH FOR SIDE OPENING IS 12'



